

Christoph Schiller

Motion Mountain

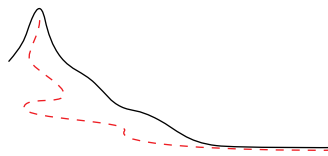

Hiking beyond space and time
along the concepts of modern physics

available at

www.motionmountain.org

Nunc editio secunda emendata.

Proprietas scriptoris Christophori Schiller
secundo anno Olympiadis vicesimae sextae
tertioque anno Olympiadis vicesimae septimae.

Omnia proprietatis jura reservantur et vindicantur.
Imitatio prohibita sine auctoris permissione.

Second revised edition

Copyright © 1997, 1998, 1999, 2000, 2001, 2002 by Christoph Schiller,
from the second year of the 26th olympiad
to the third year of the 27th olympiad.

All rights reserved. Commercial reproduction or
distribution, in whole or in part, is not allowed
without the written consent of the copyright owner.

Picture credits are listed on page **869**.

The author can be reached at cs@motionmountain.org by email.

To C.

τῷ ἔμῳ δαίμονι

Die Menschen stärken, die Sachen klären.

CONTENT OVERVIEW

1. An appetizer	20
FIRST PART : CLASSICAL PHYSICS HOW DO THINGS AND IMAGES MOVE?	
CHAPTER II CLASSICAL MOTION	25
2. Why care about motion?	25
3. Galilean physics – motion in everyday life	37
4. Global descriptions of classical motion – the simplicity of complexity	113
5. Limits of Galilean physics – what is wrong with school physics	164
6. Special relativity – rest at any speed	168
CHAPTER III GRAVITATION AND RELATIVITY	233
7. The new ideas on space, time, and gravity	233
8. Motion in general relativity – bent light and wobbling vacuum	250
9. Why can we see the stars? – Motion in the universe	281
10. Does space differ from time?	309
11. Black holes – falling forever	314
12. General relativity in ten points – a summary for the layman	325
CHAPTER IV CLASSICAL ELECTRODYNAMICS	339
13. Liquid electricity, and invisible fields	339
14. What is light?	362
15. Lightning, levitation, and other fun challenges	379
CHAPTER V CLASSICAL PHYSICS IN A NUTSHELL	409
INTERMEZZO THE BRAIN, LANGUAGE, AND THE HUMAN CONDITION	414
SECOND PART : QUANTUM THEORY WHAT IS MATTER? WHAT ARE INTERACTIONS?	
CHAPTER VI QUANTA OF LIGHT AND MATTER	480
16. An appetizer – quantum theory for lawyers	480
17. Light – the strange consequences of the quantum of action	491
18. Motion of matter – the end of classical physics	506
19. Interactions of light and matter – simple QED	510
CHAPTER VII PERMUTATION OF PARTICLES	519
20. Are particles like condoms?	519
21. Rotations and statistics – visualizing spin	527

CHAPTER VIII	DETAILS ON QUANTUM THEORY AND ELECTROMAGNETISM	538
22.	Superpositions and probabilities – quantum theory without ideology	538
23.	Applications of quantum mechanics – living beings, pleasure, and more	558
24.	Quantum electrodynamics – the origin of virtual reality	577
25.	Quantum mechanics with gravitation – first approaches	590
CHAPTER IX	INSIDE THE NUCLEUS	610
26.	The structure of the nucleus – the densest clouds	610
27.	The strong nuclear interaction	612
28.	The weak nuclear interaction	618
29.	The standard model of elementary particle physics – as seen on tv	626
30.	Grand unification – a dream	627
CHAPTER X	ADVANCED QUANTUM THEORY	631
CHAPTER XI	QUANTUM PHYSICS IN A NUTSHELL	645
INTERMEZZO	BACTERIA, SPERM, FLIES, AND KNOTS	660

THIRD PART : MOTION WITHOUT MOTION
WHAT ARE SPACE, TIME, AND PARTICLES?

CHAPTER XII	GENERAL RELATIVITY VERSUS QUANTUM MECHANICS	669
31.	Does matter differ from vacuum?	671
32.	Nature at large scales – is the universe something or nothing?	700
33.	The physics of sex – a summary of the first two and a half parts	721
34.	The shape of points	732
CHAPTER XIII	M-THEORY	784
35.	A web of dualities	784
CHAPTER I	THE TOP OF THE MOUNTAIN	787

APPENDICES

APPENDIX A	NOTATION AND CONVENTIONS	801
APPENDIX B	UNITS, MEASUREMENTS, AND CONSTANTS	811
APPENDIX C	PARTICLE PROPERTIES	827
APPENDIX D	NUMBERS AND SPACES	842
APPENDIX E	INFORMATION SOURCES ON MOTION	858
APPENDIX F	LIST OF FIGURES	863
APPENDIX G	LIST OF TABLES	870
APPENDIX H	CHALLENGE HINTS AND SOLUTIONS	872



CONTENTS

Foreword	17
1. An appetizer	20
FIRST PART : CLASSICAL PHYSICS HOW DO THINGS AND IMAGES MOVE?	
CHAPTER II CLASSICAL MOTION	25
2. Why care about motion?	25
Does motion exist? 26 How should one talk about motion? 28 What are the types of motion? 29 Do you dislike formulas? 32 Perception, permanence and change 32 Does the world need states? 34 Curiosities and challenges on motion 36	
3. Galilean physics – motion in everyday life	37
What is velocity? 37 What is time? 38 Does time flow? 43 What is space? 44 Are space and time absolute or relative? 47 Size: why area exists, but volume does not 47 What is straight? 49 Curiosities and fun challenges on everyday space and time 50	
How to describe motion: kinematics	51
What is rest? 53 Objects and point particles 55 Legs and wheels 57 Objects and images 59 Motion and contact 60 What is mass? 60 Is motion eternal? 64 More on conservation 66 Rotation 67 Rolling wheels 70 How do we walk? 71 Is the earth rotating? 72 Does the earth move? 76 Curiosities and fun challenges of everyday motion 79 Legs or wheels? – again 82	
The dynamics of gravitation	83
Properties of gravitation 85 Gravitation in the sky 89 The moon 89 Orbits 91 Tides 93 Can light fall? 95 What is mass? – again 95 Curiosities and fun challenges about gravitation 97	
What is classical mechanics?	101
Should one use force? 102 Complete states: initial conditions 107 Do surprises exist? Is the future determined? 108 A strange summary about motion 111	
4. Global descriptions of classical motion – the simplicity of complexity	113
The principle of least action	116
Why is motion so often bound? 122 Curiosities and challenges about Lagrangians 126	
Motion and symmetry	127
Why can we think and talk? 128 Viewpoints 128 Symmetries and groups 130 Representations 130 Symmetries, motion and Galilean physics 133 Reproducibility, conservation, and Noether’s theorem 136	
Simple motions of extended bodies – Oscillations and waves	140
Fun challenges about waves and extended bodies 140	
Do extended bodies exist?	141

Mountains, manifolds and fractals	141	Can a chocolate bar last forever?	142
How high can animals jump?	143	Felling trees	143
Listening to silence	144	Little hard balls	145
Challenges about fluids and other extended bodies	147	Why are objects warm?	147
Brownian motion	149	Why do balloons take up space?	151
Entropy	152	Do isolated systems exist?	156
Why can't we remember the future?	156	Is everything made of particles?	157
Curiosities and fun challenges about heat	157	Self-organization and chaos	160
5. Limits of Galilean physics – what is wrong with school physics	164	Research topics in classical dynamics	165
What is contact?	165	Precision and accuracy	166
Why is measurement possible?	166	6. Special relativity – rest at any speed	168
Can one play tennis using a laser pulse as ball and mirrors as rackets?	171	Acceleration of light and the Doppler effect	172
Can one shoot faster than one's shadow?	174	The principle of special relativity	177
What is space-time?	180	Can we travel to the past? – Time and causality	181
Curiosities of special relativity	182	Faster than light: how far can we travel?	182
Synchronization and aging: can a mother stay younger than her own daughter? – Time travel to the future	183	Length contraction	184
Which is the best seat in a bus?	185	How fast can one walk?	185
Is the speed of shadow greater than the speed of light?	186	Parallel to parallel is not parallel – Thomas rotation	188
A never-ending story: temperature and relativity	189	Relativistic mechanics	189
Mass in relativity	190	Why relativistic pool is more difficult	191
Mass is concentrated energy	191	Collisions, virtual objects and tachyons	194
Systems of particles: no centre of mass	195	Why is most motion so slow?	196
Four-vectors	196	Rotation in relativity	200
The action of a free particle	202	Conformal transformations: Why is the speed of light constant?	203
Accelerating observers	204	Accelerating frames of reference	206
Event horizons	209	Acceleration changes colours	210
Can light move faster than c ?	210	What is the speed of light?	211
Limits on the length of solid bodies	211	Special relativity in four sentences	213
References	215	CHAPTER III GRAVITATION AND RELATIVITY	233
7. The new ideas on space, time, and gravity	233	Rest and free fall	233
What is gravity?	234	What tides tell about gravity	236
Bent space	239	The speed of light and the constant of gravitation	242
Why does a stone thrown into the air fall back? – Geodesics	243	General relativity in everyday life	246
Curiosities about gravitation	246	What is weight?	249
Why do apples fall?	250	8. Motion in general relativity – bent light and wobbling vacuum	250
Weak fields	251	The Thirring effects	251
Gravitomagnetism	252	Gravitational waves	254
Light and radio wave bending	259	Time delay	260
Orbits	260	The geodesic effect	262
How is curvature measured?	263		

Curvature and space-time 266	Curvature and motion in general relativity 267
Universal gravity 268	The Schwarzschild metric 268
Curiosities and fun challenges 269	
All observers: heavier mathematics	269
The curvature of space-time 269	The description of momentum, mass and energy 271
The symmetry of general relativity 272	Mass and ADM 272
Hilbert's action 273	Einstein's field equations 273
How to calculate the shape of geodesics 276	Is gravity an interaction? 277
Riemann gymnastics 279	
9. Why can we see the stars? – Motion in the universe	281
Which stars do we see at all? 281	What do we see at night? 282
What is the universe? 285	The colour and the motion of the stars 285
Do stars shine every night? 287	A short history of the universe 287
The history of space-time 290	Why is the sky dark at night? 294
Is the universe open, closed or marginal? 295	Why is the universe transparent? 296
The big bang and its consequences 297	Was the big bang a big bang? 298
Was the big bang an event? 298	Was the big bang a beginning? 298
Does the big bang imply creation? 299	Why can we see the sun? 300
Why are the colours of the stars different? 300	Are there dark stars? 302
Are all stars different? – Gravitational lenses 302	What is the shape of the universe? 303
What is behind the horizon? 304	Why are there stars all over the place? – Inflation 305
Why are there so few stars? The energy and entropy content of the universe 305	Why is matter lumped? 306
Why are stars so small compared with the universe? 306	Are stars and galaxies moving apart or is the universe expanding? 306
Is there more than one universe? 307	Why are the stars fixed? – Arms, stars, and Mach's principle 307
Resting in the universe 308	Does light attract light? 308
Does light decay? 309	
10. Does space differ from time?	309
Can space and time be measured? 311	Are space and time necessary? 312
Do closed timelike curves exist? 312	Is general relativity local? – The hole argument 312
Is the earth hollow? 313	Are space, time and mass independent? 314
11. Black holes – falling forever	314
Why study them? 314	Horizons and orbits 315
Hair and entropy 318	Paradoxes, curiosities, and challenges 322
Formation of and search for black holes 323	Singularities 324
A quiz: is the universe a black hole? 325	
12. General relativity in ten points – a summary for the layman	325
The accuracy of the description 326	Research in general relativity and cosmology 328
The limits of general relativity 328	
References	329
CHAPTER IV CLASSICAL ELECTRODYNAMICS	339
13. Liquid electricity, and invisible fields	339
Amber, lodestone, and mobile phones	340
How can one make lightnings? 341	What is electric charge? 343
Can one feel the inertia of electricity? 347	How fast do charges move? 348
How can one make a motor? 349	How motors prove relativity right 352
The description of electromagnetic field evolution	353
The gauge field: the electromagnetic vector potential 355	Colliding charged particles 357
The Lagrangian of electromagnetism 358	Symmetries: the energy-momentum tensor 359
What is a mirror? 360	What is the difference between electric and magnetic fields? 361
14. What is light?	362

Does light travel straight? 368	Can one touch light? 370	War, light, and lies 372	
What is colour? 372	What is the speed of light? – Again 374	Signals and predictions 376	
Why can we talk to each other? – Huygens' principle 377	How does the world look when riding on a light beam? 377	Does the aether exist? 378	
15. Lightning, levitation, and other fun challenges			379
Is lightning a discharge? – Electricity in the atmosphere 382	Electrical nerves 384		
How to prove you're holy 384	Do we see what exists? 385	How does one make pictures of the inside of the eye? 386	
Does gravity make charges radiate? 387			
How does one make holograms and other 3-d images? 387	Research questions 388		
Levitation 389	Matter, levitation and electricity 391	Why can we see each other? 398	
Could electrodynamics be different? 400	A summary of classical electrodynamics and of its limits 400		
References			401
CHAPTER V CLASSICAL PHYSICS IN A NUTSHELL			409
The future of planet earth			410
The essence of classical physics			412
Why is our mountain ascent not finished yet?			412
INTERMEZZO THE BRAIN, LANGUAGE, AND THE HUMAN CONDITION			414
Evolution 415			
Children and physics			415
Why a brain? 419	What is information? 420	What is memory? 421	The capacity of the brain 422
What is language?			424
Are there semantic primitives in physics? 427	What is a concept? 427	What are sets? What are relations? 429	Infinity 431
Functions and structures 432	Numbers 434	Why use maths? 438	Is mathematics a language? 439
Curiosities and fun challenges 440			
Physical concepts and patterns of nature			440
Are physical concepts discovered or created? 441	How do we find physical patterns and rules? 443	What is a lie? 444	Is this statement true? 448
Observations			449
Have enough observations been recorded? 449	Are all observables known? 450		
Do observations take time? 452	Is induction a problem in physics? 452		
The quest for precision and its implications			455
What are interactions? 455	What is existence? 456	Do things exist? 457	Does the void exist? 459
Is nature infinite? 460	Is the universe a set? 460	Does the universe exist? 462	What is creation? 462
Is nature designed? 464	What is a description? 465	Reason, purpose, and explanation 465	Unification and demarcation 467
Pigs, apes, and the anthropic principle 468	Does one need cause and effect in explanations? 469	Is consciousness required? 470	Curiosity 470
Courage 472			
References			474

SECOND PART : QUANTUM THEORY
WHAT IS MATTER? WHAT ARE INTERACTIONS?

CHAPTER VI QUANTA OF LIGHT AND MATTER	480
16. An appetizer – quantum theory for lawyers	480
17. Light – the strange consequences of the quantum of action	491
What is colour? 491 What is light? – Again 494 Size of photons 495 Are photons countable? – Squeezed light 495 Position of photons 497 Are photons necessary? 498 How can a wave be made of particles? 500 Can light move faster than light? – Virtual photons 504 Electric fields 505	
18. Motion of matter – the end of classical physics	506
Wine glasses and pencils 506 Matter particles 506 No north pole 508	
19. Interactions of light and matter – simple QED	510
What are stars made of? 510 What determines the colour of atoms? 510 Relativistic wave equations 510 Antimatter 511 Transforming light into matter 512	
Compositeness 512	
Curiosities and challenges in quantum theory	513
The strength of electromagnetism 514	
References	515
CHAPTER VII PERMUTATION OF PARTICLES	519
20. Are particles like condoms?	519
Why does indistinguishability appear in nature? 520 Can particles be counted? 521	
What is permutation symmetry? 523 Indistinguishability and symmetry 523 The energy dependence of permutation symmetry 524 Indistinguishability in quantum field theory 525 How accurately is permutation symmetry verified? 526 Copies, clones, and condoms 526	
21. Rotations and statistics – visualizing spin	527
The belt trick 529 Pauli’s exclusion principle 531 Integer spin 532 Is spin a rotation about an axis? 533 Why is fencing with laser beams impossible? 533	
Rotation requires antiparticles 534 Limits and open questions 535	
References	535
CHAPTER VIII DETAILS ON QUANTUM THEORY AND ELECTROMAGNETISM	538
22. Superpositions and probabilities – quantum theory without ideology	538
Why are people either dead or alive?	538
Conclusions on decoherence, life, and death 545	
What is a system? What is an object?	545
Is quantum theory non-local? – A bit about EPR 546 Curiosities 548	
What is all the fuzz about measurements in quantum theory?	549
Hidden variables 553	
Conclusions on probabilities and determinism	555
What is the difference between space and time? 557 Are we good observers? 557	
Does the ‘wavefunction of the universe’ exist? 557	
23. Applications of quantum mechanics – living beings, pleasure, and more	558
Biology	558
Reproduction 559 Quantum machines 559 How do we move? – Molecular motors 560	
The physics of pleasure	562
The brain 563 Why can we observe motion? 563 Clocks in quantum mechanics 563 Do clocks exist? 565 Why are predictions so difficult, especially of the	

A mountain hike along the concepts of modern physics	13
Curiosities about the electroweak interactions	624
Neutrino 625 Weak interactions and the anapole moment 626 Conclusion 626	
29. The standard model of elementary particle physics – as seen on tv	626
Curiosities 627 Open questions 627	
30. Grand unification – a dream	627
The search for the grand unification group 627 Experimental consequences 628	
Conclusion 628	
References	629
CHAPTER X ADVANCED QUANTUM THEORY	631
CHAPTER XI QUANTUM PHYSICS IN A NUTSHELL	645
Achievements in precision	645
Physical results	647
Is physics magic? 650 The dangers of buying a can of beans 650	
The essence of quantum theory	651
What is unexplained by quantum mechanics and general relativity?	653
How to delude oneself to have reached the top of motion mountain 655 What awaits us? 657	
References	658
INTERMEZZO BACTERIA, SPERM, FLIES, AND KNOTS	660
Bumblebees and other miniature flying systems 660 Swimming 661 Sphere eversion 662 Knots, tangles, and links 663 Knots in nature 665 Clouds 666	
Fluid space-time 666 Outlook 666	
References	666
 THIRD PART : MOTION WITHOUT MOTION WHAT ARE SPACE, TIME, AND PARTICLES? 	
CHAPTER XII GENERAL RELATIVITY VERSUS QUANTUM MECHANICS	669
The contradictions	669
31. Does matter differ from vacuum?	671
Planck scales 672 Farewell to instants of time 675 Farewell to points in space 676 Farewell to the space-time manifold 678 Farewell to observables and measurements 681 Can space-time be a lattice? Can it be dual? 682 Farewell to particles 683 Farewell to mass 685 Curiosities and challenges 688 The baggage left behind 690	
Some experimental predictions	691
References	695
32. Nature at large scales – is the universe something or nothing?	700
Cosmological scales 700 Maximum time 701 Does the universe have a certain age? 701 How precisely can ages be measured? 702 Does time exist? 703 What is the measurement error for the age of the universe? 704 Maximum length 708 Is the universe really a big place? 708 The boundary of space-time – is the sky a surface? 710 Does the universe have initial conditions? 710 Does	

the universe contain particles and stars? 711	Does the universe contain masses and objects? 712	Do symmetries exist in nature? 713	Is there a boundary of the universe? 714	Is the universe a set? 715	Hilbert's sixth problem settled 716	Does the universe make sense? 717	Extremal scales and open questions of physics 718	Is extremal identity a principle of nature? 719	References 720
33. The physics of sex – a summary of the first two and a half parts	721								
References	730								
34. The shape of points	732								
An intermediate summary	755								
Curiosities and challenges 756									
References	756								
CHAPTER XIII M-THEORY	784								
35. A web of dualities	784								
References	786								
CHAPTER I THE TOP OF THE MOUNTAIN	787								
References 798									
Afterthought	799								

APPENDICES

APPENDIX A NOTATION AND CONVENTIONS	801						
The symbols used in the text 801	The Latin alphabet 803	The Greek alphabet 804	The Hebrew alphabet and other scripts 806	Digits and numbers 807	Calendars 807	Abbreviations and eponyms or concepts? 808	References 809
APPENDIX B UNITS, MEASUREMENTS, AND CONSTANTS	811						
Planck's natural units 815	Other unit systems 816	Curiosities 817	Precision and accuracy of measurements 819	Basic physical constants 820	Useful numbers 824	References 824	
APPENDIX C PARTICLE PROPERTIES	827						
References 840							
APPENDIX D NUMBERS AND SPACES	842						
More numbers 842							
Complex numbers 842	Quaternions 843	Octonions 848	Other types of numbers 850	Grassmann numbers 850			
Vector spaces 850							
Algebras 852							
Lie algebras 854	Classification of Lie algebras 855	The Virasoro algebra 856					
References 857							
APPENDIX E INFORMATION SOURCES ON MOTION	858						

A mountain hike along the concepts of modern physics	15
APPENDIX F LIST OF FIGURES	863
Picture credits 869	
APPENDIX G LIST OF TABLES	870
APPENDIX H CHALLENGE HINTS AND SOLUTIONS	872
APPENDIX I SUBJECT AND NAME INDEX	874



This is a section of the freely downloadable e-textbook

Motion Mountain

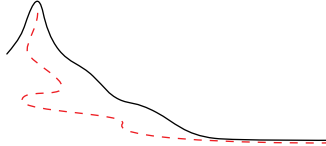

Hiking beyond space and time along the concepts of modern physics

available at
www.motionmountain.org

Copyright © 1997, 1998, 1999, 2000, 2001, 2002 by Christoph Schiller

To the kind reader

In exchange for getting this section for free, I ask you for a short email on some of the following:

Challenge 1

- Which page was boring?
- Did you find any mistakes?
- What else were you expecting?
- What was hard to understand?

Of course, any other suggestion is welcome. This section is part of a physics text written over many years. The text lives and grows through the feedback from its readers, who help to improve and to complete it. For a particularly useful contribution (send it in english, italian, dutch, german, spanish, portuguese, or french) you will be mentioned in the foreword of the text, or receive a small reward, or both.

Enjoy!

Christoph Schiller
cs@motionmountain.org

Foreword

Primum movere, deinde docere.

When watching the intensity with which small children explore their environment, we cannot avoid coming to the conclusion that there is a drive to grasp the way the world works, a ‘physics instinct’, built into each of us. What would happen if this drive, instead of dying out when the limits of the usual education are reached, were allowed to thrive in an environment without bounds, reaching from the atoms to the stars? Probably each adolescent would know more about nature than the average physics professor today. This text tries to provide this possibility to the reader. It acts as a guide for such an exploration, free of all limitations, of the exotic ‘island of motion.’

Every text on physics is a gamble. A gamble on the selection of the topics as well as a gamble on the depth with which they are treated. The present project is the result of a threefold aim I have pursued since 1990: to present the basics of *motion* in a way that is simple, up to date, and vivid. Being *simple* implies a focus on concepts and understanding, and a reduction of mathematics to the necessary minimum. It is my aim to focus on the essence of problems and to avoid unnecessary detail. Learning the language of physics is given precedence over using formulas in calculations.

Being *up-to-date* implies the inclusion of quantum gravity, string theory, and M theory. These domains have led to numerous results not yet found in books accessible to undergraduates. But also the standard topics of mechanics, light, quantum theory, and general relativity are greatly enriched by a systematic collection of modern results scattered around the scientific literature and not yet commonly found in textbooks. However, the topic of this text being the fundamentals of motion, domains like material physics, biophysics, statistical physics, hydrodynamics, self-organization, and much of nuclear physics are skipped, despite their interest.

Being *vivid* means to challenge, to question, and to dare. The text is everywhere as provocative as possible without being wrong. I avoid boredom as much as possible. I try to make the intellectual interest of the physical description of nature as apparent as possible. Many physics texts tend to be commented formula collections drowning the beauty of the topic in pages and pages of formalism. My experience with colleagues, physics students and laymen has shown that the best way to produce interest in a topic is to make a simple and correct, but surprising statement. Surprises confuse, anger, open the mind, and thus reveal something about oneself and the world. Therefore this text is built around a collection of the most astonishing facts known on the topic of motion. In my view, reading a book on general physics should be similar to a visit to a magician’s show. One watches, is astonished, doesn’t believe one’s eyes, thinks, and then understands the trick. Nature is similar: many things are different from what they appear. The text tries to follow a simple rule: *On each page, there is at least one surprise or one provocation to think.*

The surprises are organized to lead in a natural way to the most astonishing of all, namely that space and time do not exist, and that these concepts, so useful they may be in everyday life, are only approximations which are not valid in all cases. Time and space turn out to be mental crutches which *hinder* the complete exploration of the world. This text is

an introduction on how to think without using these concepts. The constant exposition to surprises prepares for this aim.

Surprises have the strongest effect whenever they question everyday observations. Therefore the examples in this text are taken as much as possible from daily life; most are taken from the experiences made when climbing a mountain. Observations about trees, stones, the moon, the sky, and people are used wherever possible; complicated laboratory experiments are mentioned only where necessary.

Books are an old-fashioned means of communication; their possibilities for interactivity are limited. Nevertheless, I want to make it clear that the study of motion, like the rest of science, must be seen as part of the entertainment industry. To achieve this, I tried to make the reader discover and enjoy conceptual physics in the same way that he enjoys a good story. All good stories are adventure stories, and the most intense adventures are those encountered during youth. This text is modelled on the way that children discover and enjoy the world around them. Numerous challenges are proposed: some hard, some less hard. Most, but not all, are answered later in the text. In addition, the walk is as structured and as complete as possible. Every topic can be enjoyed by itself, and builds at most on what was told previously. All children discover the world starting from scratch and learning, step by step, from what they encounter in everyday life. This happens here as well.

Children are often refreshingly direct. In this adventure, a clear and consistent line of thought is presented, even though it may often be somewhat controversial. On the other hand, children are flexible; they like to turn situations around and explore them from new and fresh viewpoints. In physics likewise, viewpoints must be changed regularly to get to the bottom of things. For example, the definitions of terms such as ‘object’, ‘particle’, ‘state’, ‘mass’, ‘space’, ‘vacuum’, or ‘time’ are changed several times during this adventure, as indeed happened in the history of the subject.

Children also like to dare. Courage is needed to drop space and time as tools for the description for the world and to approach nature with the openness of complete freedom from preconceptions. Just ask a physicist whether the world is deterministic or space continuous, and whether he would put his hand in the fire about the answer. Emotions will quickly run high: changing thinking habits produces fear. But nothing is more challenging, intense and satisfying than overcoming one’s own fears.

Challenge 18

The literature, lectures, and mass media regularly produce statements on physics which do not hold water when subjected to close scrutiny. The uncovering of such beliefs forms an important part of the surprises mentioned above. The persistence of many of these statements is sometimes amazing, sometimes saddening and sometimes hilarious; but in most cases it blocks the advance of understanding. This text does its best to cut down the number of lies, simply because lies reduce the intensity of life and the strength of people. With the freedom of thought thus achieved, we are ready to intensely enjoy our curiosity and to be fully entertained by its discoveries.

Many people who have kept the flame of their childhood curiosity alive have helped to make this project come true. Fernand Mayné, Saverio Pascazio, Anna Koolen, Ata Masafumi, Roberto Crespi, Serge Pahaut, Valentin Altarez Menendez, Frank van Heyningen and Maria Scali, Luca Bombelli, Herman Elswijk, Marcel Krijn, Marc de Jong, Martin van der Mark, Kim Jalink, my parents Peter and Isabella Schiller, Mike van Wijk, Renate Georgi, Paul Tegelaar, Ron Murdock, and especially my wife Britta have given me encouragement,

maybe the most precious of presents. The project and the collection of material owes much to numerous acquaintances from my work environment and from the internet, amongst them Bert Peeters, Anna Wierzbicka, William Beaty, Jim Carr, John Merrit, John Baez, Frank Di-Filippo, Jonathan Scott, Jon Thaler, Luca Bombelli, Douglas Singleton, George McQuarry, Tilman Hausherr, Brian Oberquell, Peer Zalm, Martin van der Mark, Vladimir Surdin, Julia Simon, Antonio Fermani, Don Page, Stephen Haley Peter Mayr, Allan Hayes, Norbert Dragon, Igor Ivanov, Doug Renselle, Wim de Muynck, Steve Carlip, Tom Bruce, Ryan Budney, Gary Ruben, Chris Hillman, Olivier Glassey, Jochen Greiner, squark, Martin Hardcastle, Mark Biggar, Pavel Kuzin, Douglas Brebner, Luciano Lombardi, Franco Bagnoli, Lukas Fabian Moser, Dejan Corovic, Paul Vannoni, John Haber, Saverio Pascazio, Klaus Finkenzeller, Leo Volin, Jeff Aronson, Roggie Boone, Lawrence Tuppen, Quentin David Jones, Arnaldo Uguzzoni, Frans van Nieuwpoort, Jonatan Kelu, Alan Mahoney, and in particular by the extensive, passionate, and conscientious help by Adrian Kubala. The software tools were refined with help from Sebastian Rahtz, Don Story, Vincent Darley, Johan Linde, Joseph Hertzlinger, Rick Zaccone, and John Warkentin; but the most valuable help came from Donald Arsenau.

In a simple view of the world there are three types of adventures: those of the body, of the mind, and of emotions. Achieving a description of the world without the use of space and time is one of the most beautiful of all the possible adventures of the mind. The gamble of writing this text paid off if it can purvey this.

Eindhoven and Berlin, 14 July 2002

A handwritten signature in black ink, consisting of a stylized 'S' followed by a horizontal line and a small flourish.

1. An appetizer

Die Lösung des Rätsels des Lebens in Raum und Zeit
liegt *außerhalb* von Raum und Zeit.*
Ludwig Wittgenstein, *Tractatus*, 6.4312

What is the most daring, amazing, and exciting journey we can make in a lifetime? What is the most interesting place to visit? We can travel to places as remote as possible, like explorers or cosmonauts, we can look into places as far as imaginable, like astronomers, we can visit the past, like historians or archaeologists, or we can delve as deeply as possible into the human soul, like artists or psychologists. All these voyages lead either to other places or to other times (or nowadays, to other servers on the internet). However, we can do better; the most daring trip is not the one leading to the most inaccessible place, but the trip leading to where there is no place at all. Such a journey implies leaving the prison of space and time and venturing beyond it, into a domain where there is no position, no present, no future, and no past, where we are free of all restrictions, but also of any security of thought. There, discoveries are still to be made and adventures to be fought. Almost nobody has ever been there; humanity took 2500 years to complete the trip, and has achieved it only recently.

To venture into this part of nature, we need to be curious about the essence of travel itself, in particular about its most tiny details. The essence of any travel is *motion*. In principle, the quest to understand motion in all its details can be pursued behind a desk, with a book, some paper and a pen. But to make the adventure more apparent, this text tells the story of the quest as the ascent of a high mountain. Every step towards the top corresponds to a step towards higher precision in the description of motion. At the same time, each step will increase the pleasure and the delights encountered. At the top of the mountain we will arrive in the domain we were looking for, where ‘space’ and ‘time’ are words which have lost all content, and where the sight of the world’s beauty is overwhelming and unforgettable.

The numerous challenges faced when trying to describe the world without space or time can be experienced with the following self-test:

Challenge 35

- Can you *prove* that two points extremely close to each other always leave room for a third one in between?
- Can you describe the shape of a knot through the telephone?
- Have you ever tried to make a telephone appointment with a friend without using any time or position term, such as clock, hour, place, where, when, at, near, before, after, near, upon, under, above, below?
- Can you explain on the telephone what ‘right’ and ‘left’ mean, or what a mirror is?
- Can you describe the fall of a stone without using space or time?
- Do you know of *any observation at all* which you can describe without concepts from the domains ‘space’, ‘time’ or ‘object’?
- Can you imagine a domain of nature where matter and vacuum are indistinguishable?
- Can you imagine a finite history of the universe, but without a ‘first instant of time’?
- Can you explain what time is? And what clocks are?
- Have you ever tried to understand why things move? Or why motion exists at all?

* The solution of the riddle of life in space and time lies *outside* space and time.

This book tells how to achieve these and other feats, bringing to completion an ancient dream of the human spirit, namely the quest to describe *every* possible aspect of motion.

Why do shoestrings usually remain tied? Why does space have three dimensions? Why not another number? It took people thousands of years to uncover the answer. In order to find it, several other simple but disturbing questions had to be answered, such as: What is space? Well, everybody knows that it somehow describes the possibilities we have to move things around. Therefore space has something to do with motion. What is motion precisely? Well, motion is change of position with time. But what is time? We often hear: 'nobody knows!' That would imply that nobody knows what space, time and motion really are. However, this is not the case any longer. Even though simple questions such as these are among the most difficult known, results from the last twenty years of research finally allow them to be answered – at least in big lines.

Why does everything fall downwards? Why is grass green, milk white, gold yellow, blood red, and hair sometimes blond and sometimes black? Why does the sun shine? Why does the moon not fall from the sky? Why is the sky dark at night? Why is water liquid and fire hot? Why is the universe so big? Why does the weather change so often? Why can birds fly but men can't? Why is there so much to learn? Why is lightning not straight? Why are atoms neither square, nor the size of cherries? Why does the floor not fall? Why are computers not faster? Why is all this not different? All these questions seem to have little in common; but the impression is wrong. They are all about motion. Indeed, they all appear and are answered in what follows.

In the course of this promenade, we learn that in contrast to personal experience, motion never stops. We learn that there are more cells in the brain than stars in the galaxy. (People almost literally have a whole universe in their head.) We learn that perfect memory cannot exist. We learn that every clock has a certain probability of going backwards. We learn that time literally does not exist. We find that all objects in the world are connected. We learn that matter and empty space cannot be distinguished precisely. We learn that when moving mirrors change speed they emit light. We learn that gravity can be measured with a thermometer. We learn that we are literally made of nothing.

What types of bodies are there? What types of interactions? Why do they produce motion? What is motion anyway? People went on asking and asking until they were able to show that bodies, motion and forces are terms which cannot be defined precisely, or even be distinguished exactly, and that they are only approximations of a single, deeper layer of nature, of which in fact they are three different manifestations. Which layer? Well, that is the story told in this text.

For children and physicists alike, delving into these connections is the way to have fun; curiosity always leads to strong emotions. This adventure into the unknown, with its fascinating, frightening and mysterious sides, is divided into three parts. Don't panic. All topics will be introduced step by step, in such a way that they all can be understood and enjoyed.

How do things move? The usual answer states that all motion is some thing changing position over time. This seemingly boring statement encompasses general relativity, one of the most incredible descriptions of nature ever imagined. We find that space is warped, that

light does not usually travel straight, and that time is not the same for everybody. We also discover that gravity is not an interaction, but rather the change of time with position in space, that the surface of the earth can be seen as continually accelerating upwards, and that the blackness of the sky at night proves that the universe has a finite age. These and other strange properties of motion are summarized in the first part of this text, on classical physics. They lead directly to the next question:

What are things? Things are composites of a few types of particles. In addition, all interactions and forces – those of the muscles, those which make the sun burn, those which make the earth turn, those which decide over attraction, repulsion, indifference, friction, creation and annihilation – are made of particles as well. The growth of trees, the colours of the sky, the burning of fire, the warmth of a human body, the waves of the sea, and the mood changes of people are all variations of motion of particles. This story is told in more detail in the second part, that on quantum mechanics. We learn that in principle, watches cannot work properly, that it is impossible to completely fill a glass of wine, and that some people are able to transform light into matter. You still think it's boring? Just read about the substantial dangers you incur when buying a can of beans. At that point the path is prepared for the central theme of this mountain ascent:

What are particles, position, and time? The recent results of an age-long search are making it possible to start answering this question. This third part is *not complete yet*, because the final research results are not yet available. But there are good reasons to continue the adventure:

- It is *known already* that space and time are not continuous, that – to be precise – neither points nor particles exist, and that there is no way to distinguish space from time, nor vacuum from matter, nor matter from radiation. It even turns out that nature is *not* made of particles and vacuum, in contrast to what is often believed.
- It *seems* that position, time, and every particle are aspects of a complex, extended entity incessantly varying in shape.
- Mysteries which should be cleared up *in the coming years* are the origin of the three space dimensions, the origin of time, and the details of the big bang.
- Research is *presently uncovering* that motion is an intrinsic property of matter and radiation and that it appears as soon as we introduce these two concepts in the description of nature. On the other hand, it is impossible *not* to introduce them, because they automatically appear when we divide nature into parts, an act we cannot avoid due to the mechanisms of our thinking.
- Research is also *presently uncovering* that the final description of nature, with complete precision, does not use any form of infinity. We find, step by step, that all infinities appearing in the human description of nature, both the infinitely large as well as the infinitely small, result from approximations. 'Infinity' turns out to be an exaggeration which does not apply to nature at all. At the same time, we find that the precise description does not include any finite quantities either! These and many other astonishing results of modern physics will form the third part of this text.

This final part develops the present state of the search for a unified description of general relativity and of quantum mechanics which overcomes their mutual contradictions. This will be one of the most astonishing successes of physics; it will complete the description of motion in all its aspects, from the motion of electrons in the brain to the motion of stars

See page 671

on the other end of the universe. The secrets of space, time, matter and forces have to be unravelled to achieve it. It is a fascinating story, assembled piece-by-piece by thousands of researchers.

In any mountain ascent, every now and then the hiker finds something particularly Interesting. Often, he or she then takes a small detour in order to have a closer look. Sometimes an interesting route to be tried in a following trip appears. In this text, the ‘intermezzi’, the sections entitled ‘curiosities’, and the footnotes correspond to such detours. The footnotes give a selection of interesting literature into nearby fields of inquiry, to satisfy any strong curiosity in directions different from the one chosen here; books telling how to build telescopes, how to fool one’s senses of sight, how to move without tension in one’s body, how to understand colours, how to talk, how order and beauty appear in nature, how elementary particles were discovered, and many others are mentioned and recommended, selected for quality in their exposition. In contrast, the references at the end of each chapter, both the printed ones and the world-wide web sites, list sources for material used or mentioned in the text. In the electronic version of this text, clicking web site names allows to access them directly.

The text is completed by a number of appendices which list the symbols used in the notation, give the definitions of physical units, provide an overview of physical constants and particles, present intuitive definitions of some mathematical concepts, and list general sources of printed and of electronic information. Lists of all tables and figures are given, as well as an index referring to all used concepts, mentioned names, and cited authors.

At the end of the mountain ascent, on the top of the mountain, the idea of motion will have undergone a deep transformation. Without space and time, the world looks magical, incredibly simple and astonishingly fascinating at the same time: pure beauty.

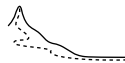

First Part

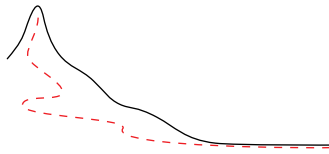

CLASSICAL PHYSICS

HOW DO THINGS AND IMAGES MOVE?

In which the experience of hiking and other everyday motion
leads us to introduce for their description
the concepts of velocity, time, length, mass, and charge,
as well as action, field, and manifold,
which allow us to understand among others
why we have legs instead of wheels,
how empty space can be bent, wobble, and move,
what sex has to do with magnets and amber,
and why we can see the stars.



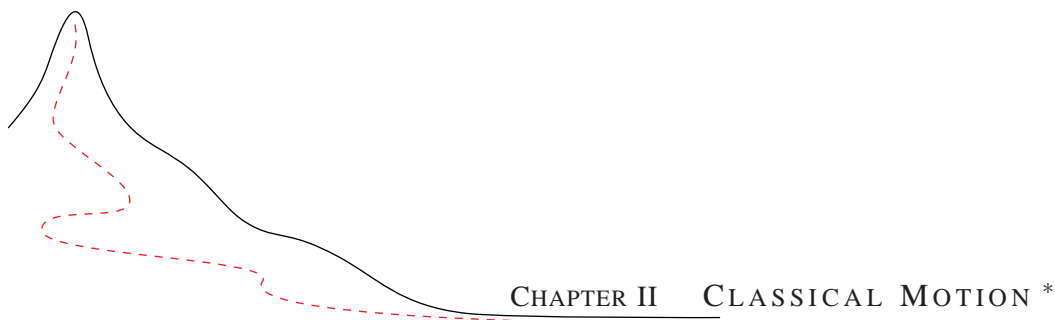

2. Why care about motion?

All motion is an illusion.
Zeno of Elea, ca. 450 BCE

Wham! The lightning crashing in the tree nearby violently disrupts our quiet forest walk and causes our hearts to suddenly beat faster. But the fire that started in the tree quickly fades away. The gentle wind moving the leaves around us helps to restore the calmness of the place. Nearby, the water in a small river follows its complicated way down the valley, reflecting on its surface the everchanging shapes of the clouds.

Motion is everywhere: friendly and threatening, horrible and beautiful. It is fundamental to our human existence; we need motion for learning, for thinking, for growing, and for enjoying life. We need it for walking through a forest, for listening to it with our eardrums and for talking about it with our vocal chords. Like all animals, we rely on motion to get food, to survive dangers,** and to reproduce; like all living beings, we need motion to breathe and to digest; like all objects, motion keeps us warm.

Motion is the most fundamental observation about nature at large. It turns out that *everything* which happens in the world is some type of motion.*** There are no exceptions. The fascination of motion has always made it a favourite subject of curiosity. Already at the beginning of written thought, during the sixth century BCE in ancient Greece, its study had been given a name: *physics*.

Ref. 1

* Since the final chapter is also the first, this is the second chapter.

** Plants for example cannot move (much); for their self-defence, they developed *poisons*. Examples of such plants are the stinging nettle, the tobacco plant, digitalis, belladonna, and poppy; poisons include caffeine, nicotine, curare, and many others. Poisons such as these are at the basis of most medicines. Therefore, most medicines exist essentially because plants have no legs.

*** Motion is such a basic part of our observations that even the origin of the word is lost in the darkness of Indo-European linguistic history.

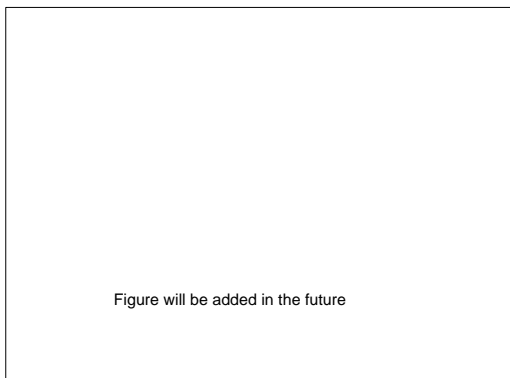

Figure 1 An example of motion observed in nature



Motion is also important to the human condition. Who are we? Where do we come from? What will we do? What should we do? What will the future bring? Where do people come from? Where do they go to? What is death? Where does the world come from? Where does life lead to? All these questions are about motion. Studying motion will provide answers which are both surprising and deep.

Motion is mysterious. Though found everywhere – in the stars, in the tides, in our eyelids – neither the ancient thinkers nor myriads of others in the following twenty-five centuries have been able to shed some light on the central mystery: *what is motion?* The standard answer, ‘motion is the change of place in time’, is inadequate, as we will discover. Only recently has an answer finally been found; this is the story of the way to reach it.

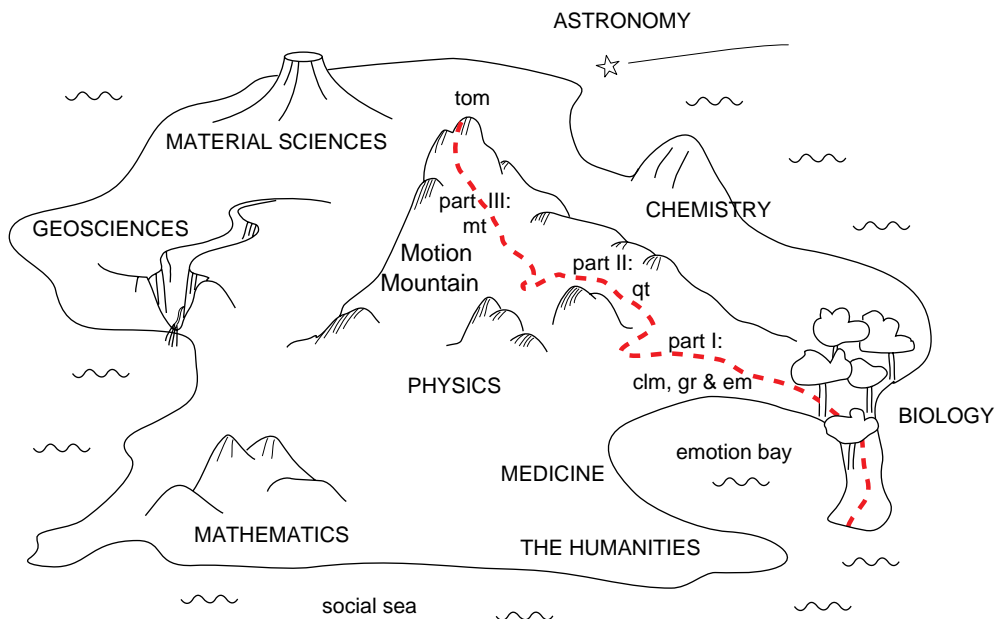

Figure 2 Experience Island, with Motion Mountain and the trail to be followed (clm: classical mechanics, gr: general relativity, em: electromagnetism, qt: quantum theory, mt: M-theory, tom: the theory of motion)

Motion is a part of human experience. If we imagine human experience as an island, then destiny, or the waves of the sea, carried us to its shore. Near the centre of the island an especially high mountain stands out. From its top we can oversee the whole landscape and get an impression of the relationships between all human experiences, in particular between all examples of motion. This is a guide to the top of Motion Mountain, as it is called. The first question to ask is:

Does motion exist?

*Das Rätsel gibt es nicht. Wenn sich eine Frage überhaupt stellen läßt, so kann sie beantwortet werden.**

* *The riddle does not exist. If a question can be put at all, it can be answered.*



Ludwig Wittgenstein, *Tractatus*, 6.5

To sharpen the mind for the issue of motion's existence, have a look at Figure 3, and slightly move the page. The figure seems to rotate. How can one make sure that real motion is different from this or some similar illusion?*

Challenge 52

Many scholars simply argued that motion does not exist at all. Their arguments deeply influenced the investigation of motion. For example, the Greek philosopher Parmenides of Elea (born ca. 515 BCE) argued that since nothing comes from nothing, change cannot be. He underlined the *permanence* of nature and thus consistently maintained that all change and thus all motion is an illusion.

Ref. 3

The opposite view was held by Heraclitos (ca. 540–ca. 480 BCE) and expressed in his sentence πάντα ῥεῖ 'everything flows'. He saw change as the essence of nature, in full contrast to Parmenides. These two equally famous opinions induced many to investigate in more detail whether in nature there are *conserved* quantities, or whether *creation* is possible. Later we will uncover the answer; would you be able to give some arguments for your favourite option?

Challenge 69

Parmenides' collaborator Zeno of Elea (born ca. 500 BCE) argued so intensely against motion that some people still worry about it today. In one of his arguments he claims – in simple language – that it is impossible to slap somebody, since the hand first has to travel halfway to the face, then travel through the remaining half, then again so, and so on; it would therefore never reach the face. This argument induces one to think carefully about the relation between *infinity* and its opposite, finitude, in the description of motion.

Ref. 4

In modern quantum theory, the same issue troubles many scientists up to this day.

Another of Zeno's provocations was to say that by looking at a moving object at a *single* instant of time, one cannot maintain that it moves. This raises the question whether motion can clearly be distinguished from its opposite, namely *rest*. In our walk, like in the history of physics, we will change from a positive to a negative answer a few times! Thinking about this question led Albert Einstein to the development of general relativity, the high point of the first part of our mountain ascent. Additionally, one is led to ask whether single instants do exist at all. This far-reaching question is central to the third part of our walk.

The second leg of the mountain ascent, that on quantum theory, will show that motion is indeed in many ways an illusion, as Parmenides claimed. More precisely, we will show that the observation of motion is due to the limitations of our human condition. We will find that we experience motion only because as human beings we evolved earth, we are of finite size, we are made of a large but finite number of atoms, we have a finite but moderate temperature, we are electrically neutral, we are large compared to a black hole of our same mass, we are large compared to our quantum mechanical wavelength, we are small compared to the universe, we have a limited memory, our brain forces us to approximate space and time as continuous entities, and only because our brain cannot avoid describing nature as made

* Solution to *challenges* are either given later on in the walk or on page 872.

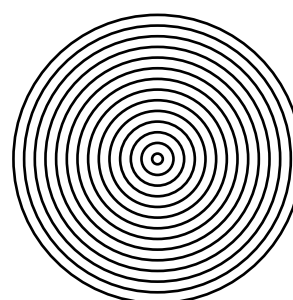

Figure 3 Illusion of motion: fake rotation



of different parts. If any one of these conditions were not fulfilled, we would not observe motion; motion then would not exist.

In order to uncover all these results in an efficient manner, one usually starts with the following question:

How should one talk about motion?

[...]
 Je hais le mouvement, qui déplace les lignes,
 Et jamais je ne pleure et jamais je ne ris.
 [...]
 Charles Baudelaire, *La Beauté*.*

Simple: with *precision* and with *curiosity*. Precision makes meaningful communication possible, and curiosity makes it worthwhile.** Whenever one talks about motion and aims for increasing precision or for more detailed knowledge, one is engaged, whether knowingly or not, in the ascent of motion mountain. With every increase in the precision of description, one gains some height towards the top.

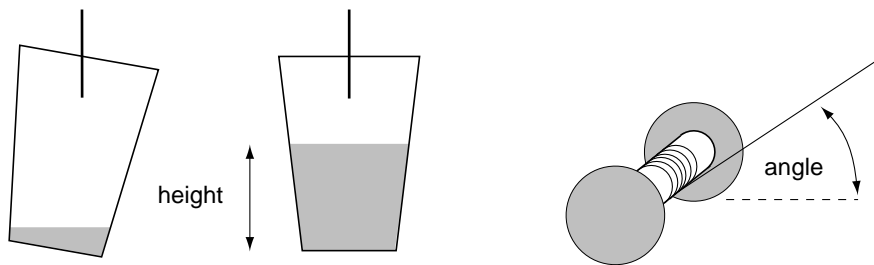

Figure 4 How much water makes a bucket hang vertically? In which direction does the reel move when pulled at an angle?

High precision means going into small details. This method actually *increases* the pleasure of the adventure.*** The higher one gets on motion mountain, the further one can see and the more curiosity gets rewarded. The views offered are breathtaking, especially at the very top. The path we will follow – one of the many possible ones – starts from the side of biology, and directly enters the forest lying at the foot of the mountain.

Ref. 6

Intense curiosity implies to go straight to the limits: understanding motion means to study the largest distances, the highest velocities, the smallest particles, the strongest forces, and the strangest concepts. Let us start.

* Charles Baudelaire (1821, Paris–1867, Paris) *Beauty*: [...] I hate movement, which changes shapes, and never do I cry and never do I laugh. [...] The full text of this and the other poems from *Les fleurs du mal*, one of the most beautiful books of poetry ever written, can be found at the <http://hypermedia.univ-paris8.fr/bibliotheque/Baudelaire/Spleen.html> web site.

** For a collection of interesting examples of motion in everyday life, see the excellent and rightly famous book by JEARL WALKER, *The flying circus of physics*, Wiley, 1975.

Ref. 5
 Challenge 86

*** Distrust anybody who wants to talk you *out* of investigating details. He is trying to get you. Be vigilant also during *this* walk.



Motion type	
motion pictures	motion therapy
motion perception	motion sickness
motion for fitness	motion for meditation
perpetual motion	motion in dance, in music and in the other arts
motion as proof of existence of various gods	motion of insects, horses, robots, stars and angels
Ref. 7	emotion
economic efficiency of motion	commotion
locomotion	movements in art, sciences and politics
motions in parliament	movements in the stock market
movements in watches	movement development in children
movement teaching and learning	troop movements
musical movements	bowel movements
religious movements	
moves in chess	

Table 1 What one can find about motion in a library

What are the types of motion?

Every movement is born of
a desire for change.

The best place to get a general answer is a big library. The domains where motion, movements and moves play a role are rather varied. Already in ancient greece people had the suspicion that all types of motion, as well as other types of change, are related. It is usual to distinguish at least three categories.

The first category is that of material *transport*, such as a person walking or a leaf falling from a tree. Transport is the change of position and orientation of objects. For example, the behaviour of people falls into this category.

Another category groups observations such as the dissolution of salt in water, the freezing of water, the putrefaction of wood, the cooking of food, the cicatrization of blood and the melting and alloying of metals. These changes of colour, of brightness, of hardness, of temperature and of other material properties are all *transformations*. Transformations are changes not visibly connected with transport. To this category, a few ancient thinkers already added the emission and absorption of light. In the twentieth century, these two effects were proven to be special cases of transformations, as were the newly discovered appearance and disappearance of matter, as observed in the sun and in radioactivity. Also *emotion change*, such as change of mood, of expression, of health, of education, and of character is (mostly) a type of transformation.

Ref. 8

Ref. 9

The third and especially important category of change is *growth*; it is observed for animals, plants, bacteria, crystals, mountains, stars, and even galaxies. In the nineteenth century, changes in the population of systems, *biological evolution*, and in the twentieth century, changes in the size of the universe, the *cosmic evolution*, were added to this category. Traditionally, these phenomena were studied by separate sciences. Independently they all



arrived at the conclusion that growth is a combination of transport and of transformation. The difference is one of complexity and of time scale.

At the beginning of modern science during the Renaissance, only the study of transport was seen as the topic of physics. Motion was equated to transport. Despite this restriction, one is still left with a large field of enquiry, covering a large part of Experience Island. The obvious way to structure the field is to distinguish transport by its origin. Movements such as those of the legs when walking are *volitional*, because they are controlled by one's will, whereas movements of external objects, such as the fall of a snowflake, which one cannot influence by will-power, are called *passive*. This distinction is completed by children around the age of six, and marks a central step in the development of every human towards a precise description of the environment. * From this distinction stems the historical but now outdated definition of physics as the science of motion of non-living things.

Then, one day, machines appeared. From that moment, the distinction between the volitional and passive motion was put into question. Machines, like living beings, are self-moving, and thus mimic volitional motion. But careful observation shows that every part in a machine is moved by another, so that their motion is in fact passive. Are living beings also machines? Are human actions examples of passive motion as well? The accumulation of observations in the past hundred years made it clear that volitional movements ** indeed have the same physical properties as passive motion in non-living systems. (Of course, from the emotional viewpoint, there are many differences; for example, *grace* can only be ascribed to volitional movements.) The distinction between the two types is thus not necessary and is dropped in the following. Since the two types of motion have the same properties, through the study of motion of non-living objects one can learn something about the human condition. This is most evident when one touches the topics of determinism, causality, probability, infinity, time, and sex, to name but a few of the themes one encounters on the way.

Ref. 10

With the accumulation of observations in the nineteenth and twentieth centuries, more and more restrictions on the study of motion were put into question. Extensive observations showed that all transformations and all growth phenomena, including behaviour change and evolution, are also examples of transport. In the middle of the twentieth century this culminated in the confirmation of an idea already formulated in ancient Greece: every type of change is a form of transport, and in particular, *every type of change is due to motion of particles*. (Do you agree?) It takes time and work to reach this conclusion, which appears only when one relentlessly pursues higher and higher precision in the description of nature. The first two parts of this walk retrace the path to this result.

Challenge 120

Then, in the third part, the particle idea is shown to be plain wrong. But until then we still have some way to go. At the present point, in the beginning of our walk, the large number of manifestations of motion and of change only tell us that classifying the various

* Failure to pass this stage completely can result in various strange beliefs, such as in the ability to influence roulette balls, as found in compulsive players, or in the ability to move other bodies by thought, as found in numerous otherwise healthy-looking people. An entertaining and informative account of all the deception and self-deception involved in creating and maintaining these beliefs is given by JAMES RANDI, a professional magician, in *The faith healers*, Prometheus Books, 1989, as well as in several of his other books. See also his <http://www.randi.org> web site for more details.

** The word 'movement' is rather modern; it was imported from the old French and became popular only at the end of the eighteenth century. It is never used by Shakespeare.



This is a section of the freely downloadable e-textbook

Motion Mountain

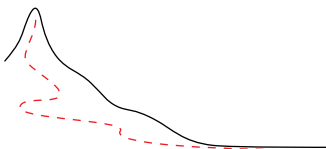

Hiking beyond space and time along the concepts of modern physics

available at
www.motionmountain.org

Copyright © 1997, 1998, 1999, 2000, 2001, 2002 by Christoph Schiller

To the kind reader

In exchange for getting this section for free, I ask you for a short email on some of the following:

- Which page was boring?
- Did you find any mistakes?
- What else were you expecting?
- What was hard to understand?

Of course, any other suggestion is welcome. This section is part of a physics text written over many years. The text lives and grows through the feedback from its readers, who help to improve and to complete it. For a particularly useful contribution (send it in english, italian, dutch, german, spanish, portuguese, or french) you will be mentioned in the foreword of the text, or receive a small reward, or both.

Enjoy!

Christoph Schiller
cs@motionmountain.org

Challenge 103



appearances of motion is not productive. Classifying motion does not allow talking about it with precision. To achieve precision, we need to select a few specific examples of motion, and study them in full detail. Only by trying to achieve maximum precision can we hope to arrive at the fundamental properties of motion.

It is intuitively obvious that the most precise description is achievable for the *simplest* possible examples. In everyday life, this is the case for the motion of any non-living, solid, rigid body in our environment, such as a stone thrown through the air. Indeed, like all humans, each of us learned to throw objects long before learning to walk. Throwing was the first act we performed ourselves in a chain of events that led us here, walking in the forest at the foot of this mountain.* During our early childhood, by throwing stones and similar objects until our parents feared for every piece of the household, we explored the properties of motion; first of all we learned that in order to describe and to understand motion we needed to distinguish *permanent* aspects, such as objects and images, and *variable* aspects, such as dimensions, position and instants.

Ref. 11

Die Welt ist unabhängig von meinem Willen.**
Ludwig Wittgenstein, *Tractatus*, 6.373

Do you dislike formulas?

If you dislike formulas, use the following three-minute method to change the situation. It is worth trying it, as it will make you enjoy this book much more. Life is short, and reading this text should be a pleasure, shouldn't it?

Ref. 8

Challenge 137

- Close your eyes and think of an experience which you had which was *absolutely marvellous*, when you felt excited, curious, and positive.
- Open your eyes for a second or two and look at page 196 or any other page of your choice which contains many formulas. Then close your eyes and return to your marvellous experience.
- Open your eyes again and look at page 196, then close them again and return to that marvellous experience.
- Repeat this three more times.

Then leave the memory, look around yourself to get back into the here and now, and test yourself. Have a look at page 196. How do you feel about formulas now?

Perception, permanence and change

Only wimps specialize in the general case;
real scientists pursue examples.
Beresford Parlett

Human beings enjoy perceiving. We start already before our birth, and continue enjoying it as long as we can. That is why television, even when devoid of content, is so successful.

* The importance of throwing is also seen from the terms derived from it: in Latin, words like subject or 'thrown below', object or 'thrown in front', and interjection or 'thrown in between'; in Greek, it led to terms like symbol or 'thrown together', problem or 'thrown forward', emblem or 'thrown into', and – last but not least – devil or 'thrown through'.

** The world is independent of my will.



During our walk through this forest, concentrated or absent-minded though we might be, we cannot avoid perceiving. Perception is first of all the ability to *distinguish*. We use the basic mental act of distinguishing in almost every instant of life; for example, during childhood we first learned to distinguish familiar from unfamiliar observations. This is possible only together with another basic ability, namely the capacity to *memorize* experiences. Without memory, we would lose the ability to experience, to talk and thus also to study nature. Together, the three activities of perceiving, classifying and memorizing form what is called *learning*. If a human were to lose any one of these three abilities, he could not study motion.

During early childhood every human rapidly learns that in all examples of motion it is possible to distinguish *permanent* from *changing* aspects. One starts to learn this with human faces, which one learns to *recognize*, even though a face never looks exactly the same as in previous observations. Anyway, when growing up, children extend recognition to all observations they make. Recognition works pretty well in everyday life; one recognizes friends even at night, and even after many beers. (Not a challenge.)

Ref. 12 Sitting on the grass in a clearing of the forest at the feet of Motion Mountain, surrounded by the trees and the silence typical of such places, a feeling of calmness and tranquillity envelops us. But suddenly, something moves in the bushes; immediately our eyes turn, the attention focuses. All these reactions are built into our body. The nerve cells which detect motion are part of the most ancient piece of our brain, shared with birds and reptiles: the brain stem. (The brain stem also controls all our involuntary motions, such as the blinking of the eyes.) Only then does the cortex, the modern brain, take over to analyse the type of motion, i.e. to try to identify its origin. Watching the motion across our field of vision, we observe two invariant entities: the fixed landscape and the moving animal. After we recognize it as a deer, we relax again. But how did we distinguish between landscape and deer?

Ref. 13 Several steps in the eye and in the brain are involved. Motion plays an essential part in them, as is best deduced from the flip movie shown in the lower left corners of these pages. Each image shows only a rectangle filled with a mathematically-random pattern. But when the pages are scanned, one discerns a shape moving against a fixed background. At any given instant, the shape cannot be distinguished from the background; there is no visible object at any given instant of time. Nevertheless it is easy to perceive its motion.* Perception experiments such as this one have been performed in many variations. Among others it was found that detecting such a window is nothing special; flies have the same ability, as do, in fact, all animals which have eyes.

Ref. 13 Like many similar experiments, the flip movie in the lower left corner shows two central connections. First, we perceive motion only if we are able to distinguish an *object* from a *background* or *environment*. Second, we need motion to define objects and environments, and to distinguish them from each other. In fact, our concept of space is an abstraction of –

* The human eye is rather good at detecting motion. For example, the eye can detect motion of a point of light even if the change of angle is smaller than what can be distinguished for fixed images. Details of this and similar

Ref. 14 topics for the other senses are the domain of perception research.



among others – the idea of background. The background is extended; the moving entity is localized. * Does his seem boring? Wait a second.

One calls the set of localized aspects which remain invariant during motion, such as size, shape, colour etc., taken together, a (physical) *object* or a (physical) *body*. We will tighten the definition shortly, since otherwise images would be objects as well. In other words, right from the start we experience motion as a *relative* process; it is perceived in relation and in opposition to the environment. Also the concept of object is therefore a relative concept. The basic conceptual distinction between localized, isolable objects and the extended environment seems trivial and unimportant. It is not. First, it smells of a circular definition. Do you agree? More about this issue later on. Second, we are so used to our ability of isolating local systems from the environment that we take it for granted. However, as we will see in the third part of our walk, this distinction turns out to be logically and experimentally impossible! ** Our walk will lead us to discover the reason for this impossibility and its important consequences.

Challenge 154

See page 689

‘Wisdom is one thing: to understand the thought
which steers all things through all things.’

Heraclitos of Ephesos

Ref. 15

Does the world need states?

Das Feste, das Bestehende und der Gegenstand sind Eins.
Der Gegenstand ist das Feste, Bestehende;
die Konfiguration ist das Wechselnde, Unbeständige. ***
Ludwig Wittgenstein, *Tractatus*, 2.027 - 2.0271

What distinguishes the various patterns in the lower left corners of this text? In everyday life we would say: the *situation* or *configuration* of the involved entities. The situation somehow describes all those aspects which can differ from case to case. It is customary to call the list of all non-permanent or *variable* aspects of a set of objects their (*physical*) *state of motion*, or simply their *state*.

The situations in the lower left corners differ first of all in *time*. Time is what makes opposites possible: a child is in a house and the same child is outside the house; time describes and resolves this type of contradiction. But the state not only distinguishes situations in time. The state contains *all* those aspects of a system (a group of objects) which set it apart from all *similar* systems. Two objects can have the same mass, the same shape, the same colour, the same composition and be indistinguishable in all other intrinsic properties; but at least they will differ in their position, or their velocity, or their orientation. The state pinpoints the individuality of a physical system, and allows one to distinguish it from exact

*The topic of motion perception is full of additional aspects. An excellent introduction is chapter 6 of the beautiful text by DONALD D. HOFFMAN, *Visual intelligence – how we create what we see*, W.W. Norton & Co., 1998. His motion illusions can be experienced and explored on the associated <http://ari.ss.uci.edu/cogsci/personnel/hoffman.html> web site.

** However, the distinction is possible in quantum theory, contrary to what is often read in popular literature; the distinction becomes impossible only when quantum theory is unified with general relativity.

*** Objects, the unalterable, and the subsistent are one and the same. Objects are what is unalterable and subsistent; their configuration is what is changing and unstable.



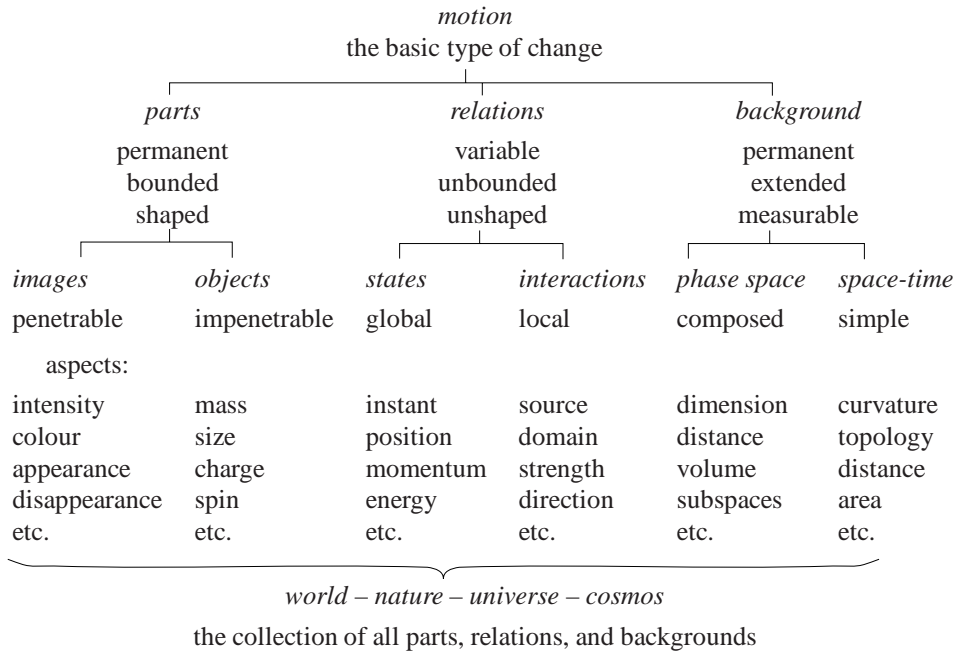

Table 2 Family tree of the basic physical concepts

copies of itself. Therefore, the state also describes the relation of an object or a system with respect to its environment. Or in short: *the state describes all aspects of a system which depend on the observer.* All this seems too boring? Then just ponder this: does the universe have a state?

Challenge 171

Describing nature as a collection of permanent entities and changing states is the starting point of the study of motion. The various aspects of objects and of their states are called *observables*. All these rough, preliminary definitions will be refined step by step in the following. Using the terms just introduced, one can say that *motion is the change of state of objects.**

In order to proceed and to achieve a *complete* description of motion, we thus need a complete description of objects and a complete description of their possible states. The first approximation is based on the precise description of what all children know about motion.

* Investigating more closely, one finds that the exact separation between those aspects belonging to the object and those belonging to the state depends on the precision of observation. For example, the length of a piece of wood is usually taken to be permanent when one constructs a house; however, more precise observations show that it shrinks and bends with time, due to processes at the molecular scale. To be precise, the length of a piece of wood is thus not an aspect of the object, but an aspect of its state. Precise observations thus *shift* the distinction between the object and its state; the distinction itself does not disappear. Only in the third part of this walk a surprising twist will appear.



Curiosities and challenges on motion

Motion is not always a simple topic.*

- Is the motion of a ghost an example of motion? Challenge 188
- Can the universe move? Challenge 205
- Can something stop moving? If yes: how would you show it? If not: does this mean that nature is infinite? Challenge 222
- To talk about precision with precision, one needs to measure it. How would you do that? Challenge 239
- Would we observe motion if we had no memory? Challenge 256
- What is the lowest speed you know? Challenge 273
- According to legend, Sessa, the indian inventor of chess, asked for the following recompensation for his invention: he wanted one grain of rice for the first square, two for the second, four for the third, eight for the fourth, and so on. How much time do all the rice fields of the world take to produce the necessary rice? Challenge 290
- When moving a burning candle, the flame lags behind. How does the flame behave if the candle is inside a glass? Challenge 307
- A frictionless ball lies near the edge of a perfectly flat and horizontal table. What happens? Challenge 324
- You step into a closed box without windows. The box is moved by outside forces unknown to you. Can you determine how you move from inside the box? Challenge 341

* Sections entitled 'curiosities' are collections of different topics that allow to check and to expand the usage of concepts introduced before.



3. Galilean physics – motion in everyday life

Die Maxime, jederzeit selbst zu denken, ist die Aufklärung.
Immanuel Kant*

Challenge 358

The simplest description of motion is the one we all, like many other living beings, use unconsciously in everyday life. Our everyday life description is based on a simple general idea: *only one thing at a time can be at a given spot*. This general idea (do you agree with it?) can be separated into three parts that characterize its general approach: matter *moves* and is *impenetrable*, time is made of *instants*, and space is made of *points*. This description of nature is called *Galilean physics*, or also *Newtonian physics*. The first name is derived from Galileo Galilei (1564–1642), Tuscan professor of mechanics, one of the founders of modern physics and a famous advocate of the importance of observations as checks of statements about nature. By requiring and performing these checks throughout his life, he was one of the first researchers on motion to insist on accuracy in its description. For example, Galileo studied motion by measuring change of position with a self-constructed stopwatch. His approach changed the speculative description of ancient Greece into the experimental physics of Renaissance Italy. He is therefore regarded as the founder of modern physics. The English alchemist, occultist, theologian, physicist, and politician Isaac Newton (1643–1727) was one of the first to pursue with vigour the idea that different types of motion have the same properties, and made important steps in constructing the concepts necessary to achieve this program.** The way that motion, points, instants, and impenetrability are described with precision only needs a short overview.

What is velocity?

There is nothing else like it.
Jochen Rindt***

On certain mornings it can be dangerous to walk in forests. When the hunting season opens, men armed with rifles ramble through the landscape, eager to use again – at last – their beloved weapon. They shoot, as malicious tongues pretend, on everything which moves, including falling leaves or fellow hunters. Here, we are going to do something similar. Like a hunter, we will concentrate on everything that moves; unlike one however, we will not seek to stop it moving, but try to follow it and to understand its motion in detail.

We observe that objects can move differently relative to each other; in particular, they can overtake each other. We also observe that objects can move in different directions. We then observe that velocities can be composed. More properties of velocity can be found in

* The maxim to think at all times by oneself is the enlightenment.

** The best and most informative book on the life of Galileo and his times is by Pietro Redondi (see the footnote on page 142). On the <http://www.mpiwg-berlin.mpg.de> web site one can read an original manuscript by Galileo. Interestingly, Galileo was born in the year the pencil was invented. Before his time, it was impossible to do paper and pencil calculations. About Newton and his importance for classical mechanics, see the text by Clifford Truesdell. About Newton's infatuation with alchemy, see the books by Dobbs. Among others, Newton believed himself to be chosen by god; he anagrammed his latin name, Isaacus Neutononus, into Jeova santus unus. Newton's other hobby, as master of the mint, was to supervise personally the hanging of counterfeiters.

Ref. 18

*** Jochen Rindt, (1942–1970), famous Austrian Formula One racing car driver.



Velocities	Physical property	Mathematical name (see later for definitions)
can		
be distinguished	distinguishability	element of set
change gradually	continuity	completeness
point somewhere	direction	dimensionality
be compared	measurability	metricity
be added	additivity	Euclidean
beat any limit	infinity	unboundedness, openness

Table 3 Properties of Galilean velocity

Table 3. For the list of all these properties, mathematicians have invented a special term; they say that velocities form a *Euclidean vector space*.^{*} More details about this strange term will be given shortly. This is an example of a general connection: every time one aims for the highest precision in describing nature, mathematical concepts are adopted.

See page 55.

When velocity is assumed to have all these properties, it is called *Galilean*. It seems that velocity is a simple and almost boring concept. Well, it is not. The first mistake: one is usually brought up with the idea that velocity needs space and time measurements to be defined first. But this is utterly wrong. Are you able to find a means to measure velocities without measuring space and time? If so, you probably want to continue reading on page 168, jumping 2000 years of inquiries. If you cannot do so, here are some hints. Whenever one measures a quantity, one assumes that everybody is able to do so, and that everybody will get the same result. This means that *measurement* is comparison with a standard. One thus implicitly assumes that such a standard exists, i.e. that an example of a ‘perfect’ velocity can be found. Historically, the study of motion did not investigate this question first, because for many centuries nobody could find this velocity, and nobody discovered this measurement method. You are thus in good company.

Ref. 18

Challenge 375

There is a second mistake in thinking that velocity is a boring subject: the latter stages of our walk will show that every single property mentioned in Table 3 is only approximate; *none* is actually correct. That is one reason that our hike is so exciting. But for the moment, we continue with the next aspect of Galilean states.

Without the concepts *place*, *empty* and *time*, change cannot be. [...] It is therefore clear [...] that their investigation has to be carried out, by studying each of them separately.
Aristotle

What is time?

Time does not exist in itself, but only through the perceived objects,

^{*} It is named after Euclid, or Eukleides, the great Greek mathematician who lived in Alexandria around 300 BCE. Euclid wrote a monumental treatise of geometry, the *Elements*, which is a milestone of human thought. It sums up all knowledge on geometry of the time, and for the first time introduces two approaches which are now common use: all statements are deduced from a small number of basic ‘axioms’, and for every statement a ‘proof’ is given. The book, still in print, has been the reference geometry text for over 2000 years.



Observation	Velocity
Stalagmite growth	ca. 0.3 pm/s
Can you find something slower?	challengeChallenge 392
Typical motion of continents	10 mm/a=0.3 nm/s
Human growth during childhood	ca. 4 nm/s
Hair growth	ca. 5 nm/s
Tree growth	up to 30 nm/s
Ketchup motion	1 mm/s
Electron speed in metals	1 mm/s
Speed of snail	5 mm/s
Slowest measured speed of light in matter	0.3 m/s Ref. 19
Speed of snow flakes	0.5 m/s to 1.5 m/s
Signal speed in human nerve cells	0.5 m/s to 120 m/s Ref. 20
Speed of rain drops, depending on radius	2 m/s to 8 m/s
Fastest swimming fish	ca. 22 m/s
Fastest running animal	ca. 30 m/s
Speed of air in throat when sneezing	ca. 42 m/s
Fastest bird	ca. 85 m/s
Average speed of oxygen molecule in air at room temperature	280 m/s
Sound speed in dry air at sea level and standard temperature	ca. 330 m/s
Record car speed	ca. 340 m/s
Speed of a rifle bullet	ca. 3 km/s
Speed of crack propagation in breaking silicon	ca. 5 km/s
Highest macroscopic speed ever achieved by man (the Voyager space probes)	14 km/s
Speed of lightning tip	ca. 100 km/s
Speed of earth through universe	ca. 370 km/s
Highest macroscopic speed measured in our galaxy	ca. $0.97 \cdot 10^8$ m/s Ref. 21
Speed of electrons inside a colour tv	ca. $1 \cdot 10^8$ m/s
Speed of radio messages in space	299972458 m/s
Highest ever measured group velocity of light	ca. $10 \cdot 10^8$ m/s
Speed of light spot from a light tower when passing over the moon	ca. $2 \cdot 10^9$ m/s
Highest proper velocity ever achieved for electrons by man	ca. $7 \cdot 10^{13}$ m/s
Highest possible velocity for a light spot	infinite

Table 4 Some velocity measurements



from which the concepts of past, of present and of future ensue. Lucretius (ca. 95–ca. 55 BCE), *De natura rerum*, lib. 1, v. 460 ss.

In their first years of life, children spend a lot of time throwing objects around. The term ‘object’ in fact is just a Latin word meaning ‘that which has been thrown in front.’ Developmental psychology has even shown experimentally that from this experience children actually extract the concepts of time and space. Adult physicists do the same when studying motion, with the difference that they repeat it consciously, using language.

Ref. 11

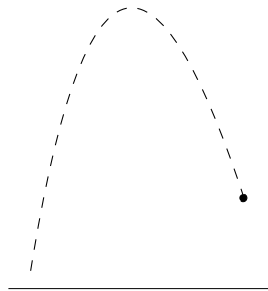

Figure 5 A typical path followed by a stone thrown through the air

Watching a stone flying through the air, one experiences the ability to define a *sequence* among observations. This ability results from the properties of our memory and of our senses. Most notably, one does this regularly with the sense of hearing, which allows to collect the various sounds during the rise, the fall and the hitting of the target. One finds that all observations one makes have other observations preceding them, observations simultaneous to them, and still others succeeding them. One says that observations happen at various *instants*, and one calls the sequence of all instants together *time*. If one wants to stress that an observation is the smallest part of a sequence, i.e. not itself a sequence, one calls it an *event*. Events are central to the definition of time, as starting or stopping a stopwatch is an event. But do events exist? You might want to ponder the question and keep it in the back of your head. We will find the definitive answer only later on.

Challenge 409

See page 675

Apart from detecting sequences, one also discovers that phenomena have an additional aspect that one calls indifferently their stretch, extension, or duration. *Duration* expresses the fact that sequences *take* time, i.e. that they cannot be accelerated or slowed down.

How exactly do we deduce the concept of time, including sequence and duration, from observation? Many people have looked into this question: astronomers, physicists, watch-makers, psychologists, and philosophers. All find that *time is deduced by comparing motions*. Children, beginning at a very young age, develop the concept of ‘time’ from the comparison of motions in their surroundings. When grown-ups take a standard the motion of the sun they call the resulting type of time *local time*; from the moon they deduce a *lunar calendar*; if they take a particular village clock on a European island they call it *universal time coordinate* (UTC), once known as ‘Greenwich mean time.’* Astronomers use the movements of the stars and call the result *ephemeris time*. An observer which uses his personal clock calls the reading his *proper time*; it is often used in the theory of relativity.

Ref. 11

Note that in the year 2000 an earth rotation does not take 86 400 seconds any more, as it did in the year 1900, but 86 400.002 seconds. Can you deduce in which year your birthday will have shifted by a whole day?

See page 818

Challenge 443

All methods for the definition of time are based on a common approach; in order to make the concept as precise as possible, a *standard* motion is picked, and with it a standard

* Official time is used to determine power grid’s phase, phone companies’ bit streams, and the signal to the GPS system which is used by many navigation systems around the world, especially in ships, aeroplanes and trucks. For more information, see the <http://www.gpsworld.com> web site. The time-keeping infrastructure is also important for other parts of the modern economy as well. Can you spot the most important ones?

Challenge 426



Observation	Duration
Shortest measurable time	ca. 10^{-44} s
Shortest time ever measured	ca. 10^{-23} s
Time for light to cross an atom	ca. 10^{-18} s
Period of caesium ground state hyperfine transition	108.782 775 707 78 ps
Wingbeat of fruit fly	ca. 1 ms
Period of pulsar (rotating star) PSR 1913+16	0.059 029 995 271 (2) s
Human ‘instant’	ca. 20 ms
Shortest lifetime of living being	ca. 0.3 d
Average length of day 400 million years ago	79 200 s
Average length of day today	86 400.002 (1) s
Your 1000 million seconds anniversary	31.7 a
Age of oldest living tree	4600 a
Time since human language is used	ca. 200 000 a
Age of Himalaya	ca. 35 to 55 · 10^6 a
Age of earth	$4.6 \cdot 10^9$ a
Age of oldest stars	ca. $12 \cdot 10^9$ a
Age of most protons in your body	ca. $12 \cdot 10^9$ a
Lifetime of tantalum nucleus ^{180}Ta	ca. 10^{15} a

Table 5 Some time measurements

sequence and a standard duration is defined. The device which performs this task is called a *clock*.^{*} We can thus answer the question of the section title: *time is what we read from a clock*. Note that all definitions of time used in the various branches of physics are equivalent to this one; no ‘deeper’ or more fundamental definition is possible. Note as a curiosity that the word ‘moment’ is indeed derived from the word ‘movement’. Language follows physics in this case. Astonishingly, the definition of time is final; it will never be changed, not even at the top of motion mountain. This is surprising at first sight, because many books have been written on the nature of time. Instead, they should investigate the nature of motion! But this is the aim of our walk anyhow. We are thus set to learn all secrets of time as a side result.

In short, a *clock* is a moving system whose position can be read out. Of course, a *precise* clock is a system moving as regularly as possible, with as little outside disturbances as possible. Is there a perfect clock in nature? Do clocks exist at all? If one goes into the details, these turn out to be tricky questions. We will continue to study them throughout our walk, and come to a conclusion only towards the end. Every clock reminds us that in order to understand time, we need to understand motion. Cheap literature often suggests the opposite, in contrast to the facts. Our first thought about clocks is that they do exist; this means that in nature there somehow is an intrinsic, natural and *ideal* way to measure time.

Challenge 460

Can you see which one?

Time is not only an aspect of observations, it is also a facet of personal experience. Even in one’s innermost private life, in one’s thoughts, feelings and dreams, one experiences

^{*} The oldest clocks are sundials. The science of making them is called *gnomonics*. An excellent and complete introduction into this somewhat strange world can be found at the <http://www.sundials.co.uk> web site.



Instants	Physical property	Mathematical name (see later for definitions)
can be distinguished	distinguishability	set
can be lined up	sequence	order
define duration	measurability	metricity
can have vanishing distance	continuity	completeness
allow to add distances	additivity	metricity
don't bring surprises	translation invariance	homogeneity
don't end	infinity	openness
can beat any limit	infinity	unboundedness
can be defined for all	absoluteness	uniqueness

Table 6 Properties of Galilean time

sequences and durations. During childhood one learns to relate this internal experience of time with external observations, and to make use of the sequential property of events in one's actions. But when one studies the origin of psychological time, one finds that it coincides – apart from its lack of accuracy – with clock time.* Every living human necessarily uses in his daily life the concept of time as a combination of sequence and duration; this fact has been checked and confirmed in numerous investigations. For example, the term 'when' is present in all human languages.

Ref. 23

Time is also a *necessary* concept of our thinking; we introduce it automatically when we distinguish between observations which are part of a sequence. There is no way to avoid time when talking about life. This seems to contradict our aim to go beyond time. In fact it doesn't, as we will find out in the third part of our mountain ascent.

All experiences collected in everyday life with help of clocks can be summarized in a few sentences. One observes that events succeed each other smoothly, apparently without end. In this context, 'smoothly' means that observations not too distant tend to be not too different. One also observes that between two instants, as close as one can observe them, there is always room for other events. One further finds that durations, called *time intervals*, measured by different people with different clocks agree in everyday life; moreover, the order in the sequence of events is unique; everybody agrees on it.

These properties form what is called *Galilean time*; it corresponds to the precise version of our everyday experience of time, as listed in Table 6. All these properties can be expressed simultaneously by describing time with the real numbers; they have been constructed to have exactly the same properties as Galilean time has, as explained in the intermezzo. Every instant of time is then described by a real number, often abbreviated t , and the duration of a sequence of events is then given by the difference between the values for the starting and the final event.

See page 438

Ref. 22 * This internal clock is more accurate than often imagined, especially when trained. For times between a few tenths of a second, as necessary for music, and a few minutes, people can achieve accuracies of a few percent. Only recently did it become clear what type of clock forms this personal time. It seems that macroscopic currents flowing around the brain in loops of about 10 cm size are at the basis of our own, conscious feeling of time. Many other clocks are also part of the human body; the time keepers for shorter times are electrical oscillators at cellular level, such as for the heart beat, and for longer times chemical reactions, such as in the monthly period.



We will have quite some fun with Galilean time. However, hundreds of years of close scrutiny have shown that *every single* property of time just listed is approximate, and none is strictly correct. Making these discoveries, with all the surprises that follow, is part of our journey.

By the way, when Galileo studied motion in the 17th century, there were no stopwatches in the shops yet. He thus had to build one himself, in order to measure times in the range between a fraction and a few seconds. Can you guess how he did it?

Ref. 24

Challenge 477

Challenge 494

What time is it at the north pole now?

Does time flow?

Wir können keinen Vorgang mit dem ‘Ablauf der Zeit’
vergleichen – diesen gibt es nicht –, sondern nur mit
einem anderen Vorgang (etwa dem Gang des Chronometers).*
Ludwig Wittgenstein, *Tractatus*, 6.3611

The ‘flow of time’ is an often-heard expression. With it one means to say that events flow, and that in nature change follows after change, in a continuous manner. But even though the hands of a clock ‘flow’,** time itself does not. Time is a concept introduced specially to describe the flow of events around us; it does not itself flow, it *describes* flow. Time does not advance. Time is neither linear nor cyclic. The idea that time flows is as hindering to understanding nature as is the idea that mirrors exchange right and left.

See page 360

Ref. 25

The confused expression ‘flow of time’, propagated first by some Greek thinkers and then again by Newton, does not want to die out. Aristotle (384–322 BCE), careful to think logically, pointed out its misconception. Nevertheless, one continues to hear expressions such as ‘time reversal’, the ‘irreversibility of time’, and, most abused of all, ‘time’s arrow.’ Time cannot be reversed, only motion can, or more precisely, only velocities of objects; time has no arrow, only motion has; it is not the flow of time which humans are unable to stop, but the motion of all the objects around. Incredibly, there are even books written by respected physicists which study different types of ‘time’s arrows’ and compare them with each other. Have a look at some of these useless texts! Predictably, no tangible or new result is extracted.

Ref. 26

Challenge 511

Confused expressions can lead reason astray in many ways; we must avoid them because they render the ascent of Motion Mountain unnecessarily difficult. They even prevent it

* We cannot compare a process with ‘the passage of time’ – there is no such thing – but only with another process (such as the working of a chronometer).

** Why do *clocks* go *clockwise*, even though all other rotational motions in our society, such as athletic races, horse races, bicycle races, ice skaters etc. go the other way? Most people are right-handed, and the right hand has more freedom at the outside of a circle. Since chariot races in stadia went counter-clockwise already thousands of years ago, all races continue to do so to this day. Also every supermarket leads its guests anticlockwise through the hall. (For the same reason, helical stairs in castle are built in such a way that defending right-handers, usually from above, have their hand on the outside.) On the other hand, the clock imitates the shadow of sundials; obviously, this is true on the northern hemisphere only. (The old trick to determine south by pointing the hour hand of an horizontal watch to the sun and halving the angle between it and the direction of 12 o’clock does not work on the southern hemisphere.) So every clock implicitly continues to tell on which hemisphere it was invented.



beyond a certain stage, located about halfway to the top. With a clear understanding of time we now can continue with the next aspect of motion states.

What is space?

The introduction of numbers as coordinates is an act of violence.
Hermann Weyl*

Why can we distinguish one tree from another? We see that they are in different positions. In fact, the capacity to distinguish positions is the main ability of our sense of sight. Whenever we distinguish two objects from each other, such as two stars, we first of all distinguish their positions. Position is therefore an important aspect of the state of an object. Positions are taken by only one object at a time. They are limited. The set of all available positions, called (*physical*) *space*, acts as both a container and a background.

Closely related with space and position is *size*, the set of positions an objects occupies. Small objects occupy only subsets of the positions occupied by large ones. We will discuss size shortly.

How do we deduce space from observations? During childhood, humans (and most higher animals) learn to bring together the various perceptions of space, namely the visual, the tactile, the auditory, the kinesthetic, the vestibular etc., into one coherent set of experiences and description. The result of this learning process is a certain ‘image’ of space in the brain. Indeed, the question ‘where?’ can be asked and answered in all languages of the world. Being more precise, adults derive space from distance measurements. The concepts of length, area, volume, angle, and solid angle are all deduced with their help. Geometers, surveyors, architects, astronomers, carpet salesmen, and producers of meter bars base their trade on distance measurements. Space is thus a concept formed to describe observations by summarizing all the distance relations between objects.

By the way, meter bars work well only if they are straight. But when humans lived in the jungle, there was not a single straight object around them. No straight rulers, no straight tools, nothing. Today, a cityscape is essentially a collection of straight lines. Can you describe how humans achieved this?

Challenge 528

Once humans came out of the jungle with their newly-built meter bars, they collected a wealth of results which are easily confirmed by personal experience. First, we observe that objects can take positions in an apparently *continuous* manner: there are more positions than can be counted. ** We further find that size is captured by defining the distance between various positions, which is called *length*, or by using the field of view an object takes when one touches it, which is called its *surface*. Length and surface can be measured with help of a meter bar. In daily life, all length measurements performed by different people coincide. We observe that the length of objects is independent of the person measuring it, of the position of the objects, and of their orientation. We also observe that in daily life the sum of angles in any triangle is equal to two right angles. Finally, we do not observe any limits in space.

* Hermann Weyl (1885–1955) was one of the most important mathematicians of his time, as well as an important theoretical physicist. He was one of the last universalists in both fields, a contributor to quantum theory and relativity, father of the term ‘gauge’ theory, and author of many popular texts.

** For a definition of uncountability, see page 431.



Points	Physical property	Mathematical name (see index for definitions)
can be distinguished	distinguishability	set
can be lined up	sequence	order
can form shapes	shape	topology
can be lined up to form knots	possibility of knots	dimensionality
define distances	measurability	metricity
can have vanishing distance	continuity	completeness
allow to add distances	additivity	linearity
don't hide surprises	translation invariance	homogeneity
don't end	infinity	openness
can beat any limit	infinity	unboundedness
can be defined for all	absoluteness	uniqueness

Table 7 Properties of Galilean space

We also observe that space has three dimensions, i.e. that we can define sequences of positions in precisely three independent ways. This can also be seen from the inner ear of (practically) all vertebrates: the ear has three semicircular canals which help the body to sense its position in the three dimensions of space.* Another proof that space has three dimensions is given by the problems posed and solved regularly by shoe-laces: if space had more than three dimensions, shoe-laces would not be useful, because knots exist only in three-dimensional space. Why three? This is perhaps the most difficult question of physics; it will be answered only in the very last part of our walk.

One often hears that thinking in four dimensions is impossible. That is wrong. Just try. For example, can you confirm that in four dimensions knots are impossible?

Challenge 545

Like time intervals, length intervals can be described most precisely with the help of *real numbers*. In order to simplify communication, one uses standard *units*, so that everybody uses the same numbers for the same length. Units allows to explore the general properties of *Galilean space* experimentally: space, the container of objects, is continuous, three-dimensional, isotropic, homogeneous, infinite, Euclidean, and unique or ‘absolute’. In mathematics, a structure or mathematical concept with all the properties just mentioned is called a three-dimensional *Euclidean space*. Its elements, (*mathematical points*), are described by three real parameters. They are usually written

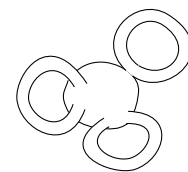
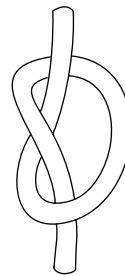

preliminary drawing

Figure 6 Two proofs of the three-dimensionality of space: a knot and the inner ear of a mammal

Its elements, (*mathematical points*), are described by three real parameters. They are usually written

$$(x, y, z) \tag{1}$$

* Note that saying that space has three dimensions *implies* that space is continuous; the mathematician L.E.J. Brower showed that dimensionality is only a useful concept for continuous sets.



Observation	Distance
Galaxy Compton wavelength	ca. 10^{-85} m (prediction only)
Planck length	ca. 10^{-35} m
Shortest measurable length	ca. 10^{-32} m
Proton diameter	ca. 1 fm
Smallest eardrum oscillation detectable by human ear	ca. 5 pm
Electron Compton wavelength	2.426 310 215(18)pm
Hydrogen atom size	30 pm
Wavelength of visible light	0.4 to $0.8 \mu\text{m}$
Size of small bacterium	ca. $5 \mu\text{m}$
Point: diameter of smallest object visible with naked eye	ca. $20 \mu\text{m}$
Total length of human DNA	ca. 2 m
Size of largest living being	ca. 100 m
Length of earth's equator	ca. 40 075 014.8(6) m
Total length of human nerve cells	$8 \cdot 10^5$ km
Average sun's distance	149 597 870 691(30)m
Light year	9.5 Pm
Distance to typical star at night	ca. 10 Em
Size of galaxy	ca. 10 Zm
Most distant visible object	ca. 100 Ym

Table 8 Some distance measurements

and are called *coordinates*, which specify or order the location of a point in space. (For the precise definition of Euclidean spaces, see page 55.)

What is described here in just half a page actually took two thousand years to be worked out, mainly because the concepts of ‘real number’ and ‘coordinate’ had to be discovered first. The first person to describe points of space in this way was the famous French-born mathematician and philosopher René Descartes (1596–1650), after whom the coordinates of expression (1) are named *Cartesian*.

Like time, space is a *necessary* concept to describe the world. Indeed, space is automatically introduced when we describe situations with many objects. For example, when many spheres lie on a billiard table, we cannot avoid using space to describe the relations among them. In everyday life we cannot avoid using spatial concepts.

By the way, even though we need space to talk about nature, it is still interesting to ask *why* this is possible. For example, since length measurement methods are possible, there must be a *natural* or *ideal* way to measure distances, sizes and straightness. Can you find it?

Challenge 562

Like in the case of time, each of the properties of space just listed has to be checked. And again, careful observations will show that each of them is an approximation. In more simple and drastic words, *all* of them are wrong. This confirms Weyl's statement at the beginning of this section; we will discover that this story is told by every forest in the world, and of course also by the one at the foot of Motion Mountain we are crossing now. We need only listen carefully to what the trees have to tell.



Are space and time absolute or relative?

In everyday life, the concepts of Galilean space and time include two opposing aspects which have coloured every discussion about them for several centuries. On one hand, space and time express something invariant and permanent; they both act like big containers for all the objects and events found in nature. Seen this way, space and time have an existence of their own. In this sense one can say that they are *fundamental* or *absolute*. On the other hand, space and time are tools of description which allow to talk about relations between objects. In this view, they do not have any meaning when separated from objects, and only result from the relations between objects; they are *relational* or *relative*. Between these two viewpoints, which one do you prefer? The results of physics have alternatively favoured one over the other; we will follow this alternation throughout our adventure, until we find the solution to the puzzle.

Challenge 579

Size: why area exists, but volume does not

We saw that a central aspect of objects was their size. All children learn the details of the shape and size of their own body. During this development, which takes place mainly before school age, every human learns how to use the properties of size and space in his actions. As precision-aiming adults, it seems obvious that with the definition of *distance* as the difference between coordinates it is possible to define *length* in a reliable way. It took hundreds of years to discover that this is *not* the case. Several investigations both in physics and in mathematics led to complications.

The physical issues started with an astonishingly simple question asked by English physicist and psychologist Lewis Fray Richardson (1881–1953): how long is the coastline of Britain?

Following the coastline on a map with an odometer, a device such as the one shown in the Figure 7, one finds that the length l of the coastline depends on the scale s (say 1/10,000 or 1/500,000) of the map used:

$$l = l_0 s^{0.36}$$

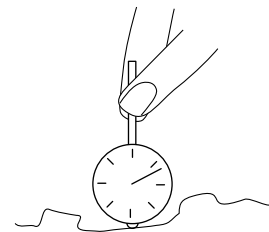

(2) Figure 7 A curvemeter or odometer

The larger the map, the longer the coastline. What would happen if the scale of the map is increased even beyond the size of the original? Can a coastline really have *infinite* length? Yes, it can. In fact, mathematicians have described many such curves, called *fractals*. There are actually an infinite number of them, and Figure 8 shows one example.* Can you construct another example?

Challenge 596

Length has other strange properties. The great mathematician Felix Hausdorff discovered that it is possible to cut a line segment of length 1 into pieces which can be reassembled – merely by shifting them in direction of the segment – into a line segment of length 2. Are

* Most of these curves are *selfsimilar*, i.e. they follow scaling laws similar to the above-mentioned, and are nowadays called *fractals*. The term is due to the Polish mathematician Benoit Mandelbrodt. Coastlines and other fractals are beautifully presented in HEINZ-OTTO PEITGEN, HARTMUT JÜRGENS & DIETMAR SAUPE, *Fractals for the classroom*, Springer Verlag, 1992, on pages 232-245. It is available also in several other languages.



you able to find such a division using the hint that it only possible using infinitely many pieces?

Challenge 613

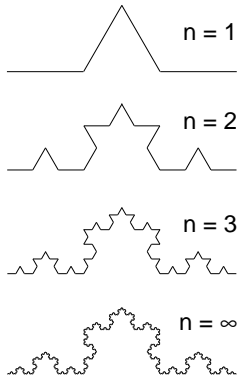

Figure 8 A fractal: a self-similar curve of infinite length, and its construction

In summary, length is well-defined for straight and nicely-curved lines, but not for intricate lines, or for lines made of infinitely many pieces. We therefore avoid fractals and other strangely-shaped curves in the following, while being careful when talking about infinitely small segments. These are central but often hidden assumptions in the first two parts of this walk, and should never be forgotten. We will come back to these assumptions in the third part.

But all these problems pale when compared to the following one. One commonly defines area and volume using length. You think it's easy? You're wrong, as well as a victim of prejudices spread by schools around the world. To define area and volume with precision, one needs definitions with two properties: the values must be *additive*, i.e. for finite and infinite sets of objects, the total area and volume have to be the sum of the areas and volumes of each element of the set; and they must be *rigid*, i.e. if one cuts an area or a volume into pieces and then rearranges them, the value remains the same. Do such concepts exist?

For areas, one proceeds in the following standard way: one defines the area A of a rectangle of sides a and b as $A = ab$; since any polygon can be rearranged into a rectangle with a finite number of straight cuts, one can define an area for all polygons. One can then define area for nicely curved shapes as limit of the sum of infinitely many polygons. This method is called *integration*, and is introduced in detail in the section on physical action as well as in the appendix.

However, integration does not allow us to define area for arbitrarily bounded regions. (Can you imagine such a region?) For a complete definition, more sophisticated tricks are needed. They were discovered in 1923 by the famous Polish mathematician Stefan Banach (Krakow, 1892–Lvov, 1945) who showed that one can indeed define an area for any set of points whatsoever, even if the border is not nicely curved but extremely complicated, such as the fractal curve just mentioned. Today this concept of area, technically a ‘finitely additive isometrically invariant measure,’ is called a *Banach measure* in his honour. Mathematicians sum up this discussion by saying that since in two dimensions there is a Banach measure, there is a way to define the concept of area – an additive and rigid property – for any set of points whatsoever.*

What is the situation in *three* dimensions, i.e. for volume? One can start in the same way as for areas, by defining the volume V of a rectangular polyhedron with sides a , b , c as $V = abc$. But then one encounters a first problem: a general polyhedron cannot be cut into a cube by straight cuts! The limitation was discovered in 1902 by the German mathematician

* Actually, this is strictly true only for the plane. For curved surfaces, such as the surface of a sphere, there are complications, but they will not be discussed here. Note also that the problems of the definition of length reappear for area if the surface to be measured is not flat but full of hills and valleys. A typical example is the area of the human lung: depending on the level of details looked at, one finds area values from a few square metres up to over 100 m^2 .

Challenge 630

See page 116

See page 856

Challenge 647



Max Dehn (1878–1952). He found that if one ascribes to every edge of a general polyhedron a number given by its length l times a special function $g(\alpha)$ of its dihedral angle α , then the sum of all the numbers for all the edges of a solid does not change under dissection, provided that the function fulfils $g(\alpha + \beta) = g(\alpha) + g(\beta)$ and $g(\pi) = 0$. An example of such a strange function g is the one giving the value zero to any rational multiple of π and the value one to any irrational multiple of π . Using this function, you may then deduce for yourself that a cube cannot be dissected into a regular tetrahedron because their Dehn invariants are different. * Despite the problems with Dehn invariants, one *can* define a rigid and additive concept of volume for polyhedra, since for all of them and in general for all ‘nicely curved’ shapes, one can again use integration for the definition of their volume.

Challenge 664

Challenge 681

See page 856

Now let us consider general shapes and general cuts in three dimensions, not just the ‘nice’ ones mentioned so far. One then gets the famous *Banach-Tarski theorem* (or paradox). In 1924, Stefan Banach and Alfred Tarski (1902, Warsaw– 1983, Berkeley) proved that it is possible to cut one sphere into five pieces which can be recombined to give two spheres, each of the size of the original. Even worse, another version of their theorem says: take any two sets not extending to infinity and containing a solid sphere each; then it is always possible to dissect one into the other with a finite number of cuts. In particular it is possible to dissect a pea into the earth, or vice versa. Size does not count! ** Volume is not a useful concept at all. ***

Ref. 27

The Banach-Tarski theorem raises two questions: can one do this with gold? In other words, is matter continuous? And can one do this blowing up with empty space? In other words, is empty space continuous? Both topics are quite different; they will be studied in the rest of our walk. For the moment, we eliminate the troubling issue altogether by restricting our interest to smoothly-curved shapes. With this restriction, volumes of matter and space behave nicely: they are additive and rigid, and show no paradoxes. Nevertheless, we need to keep in the back of our mind that the size of an object is a tricky quantity and that we need to be careful whenever we talk about it.

Challenge 698

What is straight?

When one sees a solid object with a straight edge, it is a 99%-safe bet to come to the conclusion that it is human made. **** The contrast between the objects seen in a city – houses, furniture, cars, boxes, books – and the objects seen in a forest – trees, plants, mountains,

* This is also told in the beautiful book by M. AIGLER & G.M. ZIEGLER, *Proofs from the Book*, Springer Verlag, 1999. The title is due to the famous habit of the great mathematician Paul Erdős to call beautiful mathematical proofs ‘proofs from the book.’

** The proof of the result does not need much mathematics; it is explained beautifully by Ian Stewart in *Paradox of the spheres*, New Scientist, 14 January 1995, pp. 28–31.

*** In 4 dimensions, the Banach-Tarski paradox exists as well, as it does in any higher dimension. More mathematical detail can be found in the book by STEVE WAGON, *The Banach Tarski Paradox*, Cambridge University Press, 1993.

Ref. 28

*** Exceptions are some broken crystalline minerals. Other candidates which might come to mind, such as certain bacteria which have (almost) square or (almost) triangular shapes are not real exceptions.

figure to be finished

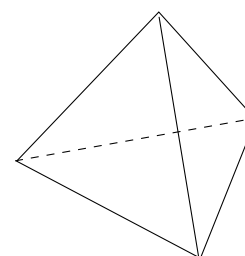

Figure 9 Polyhedra and dihedral angles



clouds – is evident: in the forest nothing is straight or flat, in the city most objects are. How is it possible for us to make straight objects while there are none to be found in nature?

Traditionally one calls any line *straight* if it touches either a plumb-line or a light ray along its whole length. Can you find another definition? In fact, the definition with the plumb line and the definition with light are equivalent. Can you confirm this? (This is not an easy question.) Obviously, we call a surface *flat* if for any chosen orientation and position it touches a plumb-line or a light ray along its whole extension.

There are people who maintain that we do not live on the outside of a spherical planet, but on the *inside* of a sphere. People who defend this version of *hollow earth theory* say that the sun and the stars are located near the centre of the hollow earth. One can indeed build a complete model of the universe based on this approach if, as they say, light does not travel in straight lines. Is this consistent with observations? We will come back to this problem in the section on general relativity.

Challenge 715

Challenge 732

See page 313

Challenge 749

See page 313

Curiosities and fun challenges on everyday space and time

Here are a few questions to make you think.

- How often in 24 hours do the hour and minute hands of a clock lie on top of each other? Challenge 766
How often does this happen for clocks having also a hand for seconds?
- How many times in twelve hours can the two hands of a clock be *exchanged* with the result that the new situation shows a *valid* time? What happens for clocks having also a third hand? Ref. 5
Challenge 783
- In 1996 the smallest experimentally probed distance was 10^{-19} m, achieved between quarks at Fermilab. What does this mean for the continuity of space? Ref. 68
Challenge 800
- Given that you know what straightness is, how would you characterize the curvature of a line using numbers? And that of a surface? Challenge 817
- What is the speed of your eyelid? Challenge 834
- Zeno studied what happens to a moving object at a given instant of time. To discuss with him, you decide to build the fastest possible shutter for a photographic camera that you can imagine. You have all the money you want. What is the shortest shutter time you would achieve? Challenge 851
- Can you prove Pythagoras's theorem by geometrical meaning alone, without using coordinates? (There are more than 30 possibilities.) Challenge 868
- Why are most planets and moons (almost) spherical? Challenge 885
- How many minutes does the earth turn in one minute? Challenge 902
- A rubber band connects the tips of the two hands of a clock. What is the path followed of the middle point of the band? Challenge 919
- Both the sun and the moon seem larger when they are on the horizon. Ptolemy already explains this illusion by an unconscious apparent distance change of the human brain. In fact, the moon is farther away from the observer when it is above the horizon, and thus its image smaller than a few hours earlier, when it was high in the sky. Can you confirm this? Challenge 936
- Cylinders can be used to move a plank over the floor; they keep the plank always at the same distance from the floor. What cross section *other* than a circle are possible to achieve the same feat? How many examples can you find? Challenge 953



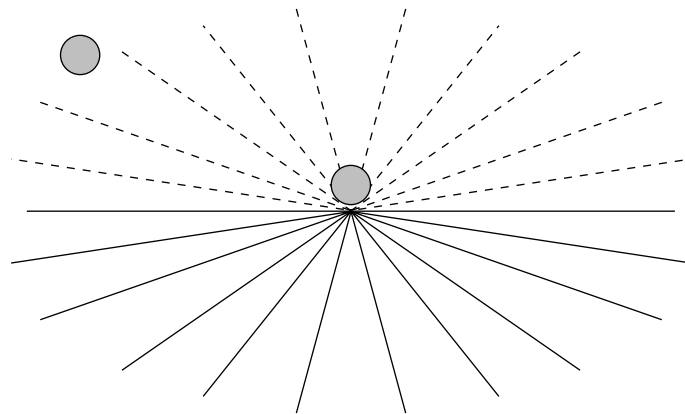

Figure 10 How the apparent size of the moon and the sun changes

▪ Also Galileo made mistakes. In his famous book, the *Dialogues*, he says that the curve formed by a thin chain hanging between two nails is a parabola. That is not correct. What is the correct curve?

Challenge 970

▪ How does a *vernier* work? It is called *nonius* in other languages, derived from the Latin word for ‘nine’. Can you design a vernier which instead of increasing the precision tenfold, does so by an arbitrary factor? Is there a limit?

Challenge 987

How to describe motion: kinematics

Il libro della natura è scritto nella lingua della matematica.*
Galileo Galilei

Experiments show that the properties of Galilean time and space are extracted from the environment by most higher animals and by young children. Later, when children learn to speak, they put these experiences into concepts, as was just done above. With help of the concepts just introduced, grown up children then say that *motion is change of position with time*. This description is illustrated by flipping rapidly the lower left corners of the pages of this book. Each page simulates an instant of time, and the only change taking place during motion is the position of the object, represented by the dark spot. The other variations from one picture to the next, due to the imperfections of printing techniques, even simulate inevitable measurement errors.

It is evident that calling motion the change of position with time is *not* an explanation of motion *nor* a definition, since both the concepts of time and position are deduced from motion itself. It is only a *description* of motion. Nevertheless, this rephrasing is useful because it allows for high *precision*, as we will find out soon. After all, precision is our guiding principle during this promenade. The detailed description of changes in position is traditionally called *kinematics*.

* The book of nature is written in the language of mathematics.



The set of all positions taken by an object over time forms a *path* or *trajectory*. The origin of this concept is evident when one watches fireworks* or again the flip movie in the lower left corner of this part of the mountain ascent. With the description of space and time by real numbers, a trajectory can be described by specifying its three coordinates (x, y, z) – one for each dimension – as continuous functions of time t . (Functions are defined in detail on page 432.) This is usually written as $\mathbf{x} = \mathbf{x}(t) = (x(t), y(t), z(t))$. For example, observation shows that the height z of any thrown or falling stone changes as

$$z(t) = z_0 + v_0(t - t_0) - \frac{1}{2}g(t - t_0)^2 \quad (3)$$

where t_0 is the time one starts the experiment, z_0 is the initial position, v_0 is the initial velocity in the vertical direction and $g = 9.8 \text{ m/s}^2$ is a constant which is found to be the same, within about one part in 300, for all falling bodies on all points of the surface of the earth. Where do the value 9.8 m/s^2 and its slight variations come from? A preliminary answer will be given shortly, but the complete elucidation will occupy us during the larger part of this hike.

Ref. 29

Equation (3) allows to determine the depth of a well given the time a stone takes to reach its bottom. The equation also gives the speed v with which one hits the ground after jumping from a tree, namely $v = \sqrt{2gh}$. A height of 3 m yields a velocity of 27 km/h. The velocity is thus proportional only to the square root of the height; does it mean that fear of falling results from an overestimation of its actual effects?

Challenge 1004

Challenge 1021

If the description of equation (3) is expanded with the two expressions for the horizontal coordinates x and y , namely

$$\begin{aligned} x(t) &= x_0 + v_{x0}(t - t_0) \\ y(t) &= y_0 + v_{y0}(t - t_0) \quad , \end{aligned} \quad (4)$$

a *complete* description for the path followed by thrown stones results. A path of this shape is called a *parabola* and is shown in Figure 11.** A parabola is also the shape used for light reflectors inside pocket lamps or car headlights. Can you show why?

Challenge 1038

The kinematic description of motion is useful to answer such questions as:

▪ What is the distance one can reach with a stone, given the speed and the angle with which it is shot?

Challenge 1055

▪ How can the speed of falling rain be measured with an umbrella?

Challenge 1072

▪ What is the maximum numbers of balls that could be juggled at the same time?

Challenge 1089

▪ What is an upper limit for the long jump record? One can use as input that the running speed world record in 1997 is $12 \text{ m/s} \approx 43 \text{ km/h}$ by Ben Johnson, and the women's record is $11 \text{ m/s} \approx 40 \text{ km/h}$. In fact, long jumpers never run much faster than about 9.5 m/s . How much could they win in length if they could run full speed? How could one achieve that? In addition, long jumpers take off at angles of about 20° , as they are not able to achieve a

Challenge 1106

Ref. 30

Ref. 69

* On the world of fireworks, see the frequently asked questions list of the usenet group rec.pyrotechnics, or search the web. A simple introduction is the article by J.A. CONKLING, *Pyrotechnics*, Scientific American pp. 66–73, July 1990.

** Apart from the graphs shown in Figure 11, there is also the *configuration space* spanned by the coordinates of all particles of a system; only for a single particle it is equal to the real space. The phase space diagram is also called state space diagram.



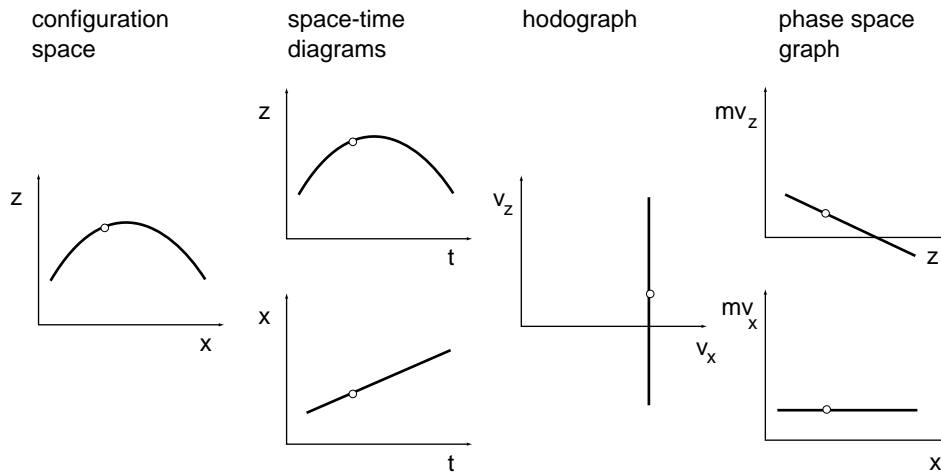

Figure 11 Various types of graphs describing the same flying stone

- Challenge 2 higher angle at the speed they are running. How much would they gain if they could achieve 45 °?
- Challenge 19 ■ Are gun bullets falling back after being fired into the air dangerous?
- Challenge 36 ■ Is it true that rain drops would kill if it weren't for the air resistance of the atmosphere? The last two questions derive from the fact that equation (3) does not hold in all cases. For example, leaves or potato chips do not follow it. This is a consequence of air resistance, which we will discuss shortly.
- Challenge 53 In fact, even without air resistance, the path of a stone would not always be a parabola; can you imagine such situations?

What is rest?

This question seems to have an obvious answer. A body is at rest when its position, i.e. its coordinates do not change with time. In other words, *rest* is

$$\mathbf{x}(t) = \text{const} \quad (5)$$

Later we will see that this definition, contrary to first impressions, is not of much use and will have to be modified. In any case, non-resting objects can be distinguished by comparing the rapidity of their displacement. One thus can define the *velocity* \mathbf{v} of an object as the change of its position \mathbf{x} with time t , usually written as

$$\mathbf{v} = \frac{d\mathbf{x}}{dt} \quad (6)$$

The *speed* v is the name given to the magnitude of the velocity \mathbf{v} . In this expression, valid for each coordinate separately, d/dt means ‘change with time’; one can thus say that velocity

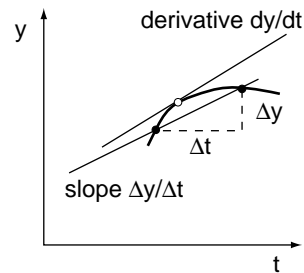

Figure 12 Derivatives



is the *derivative* of space with respect to time. Derivatives are written as fractions as a reminder that they are derived from the idea of slope. The expression

$$\frac{dy}{dt} \text{ is meant as an abbreviation of } \lim_{\Delta t \rightarrow 0} \frac{\Delta y}{\Delta t}, \quad (7)$$

a shorthand for saying that the *derivative at a point* is the limit of the slopes in the neighbourhood of the point, as shown in Figure 12. From this definition follow the working rules

Challenge 70

$$\frac{d(y+z)}{dt} = \frac{dy}{dt} + \frac{dz}{dt}, \quad \frac{d(cy)}{dt} = c \frac{dy}{dt}, \quad \frac{d}{dt} \frac{dy}{dt} = \frac{d^2y}{dt^2}, \quad \frac{d(yz)}{dt} = \frac{dy}{dt}z + y \frac{dz}{dt} \quad (8)$$

c being any number. This is all one ever needs to know about derivatives. The quantities dt and dy , sometimes useful by themselves, are called *differentials*. These concepts are due to the Saxon lawyer, physicist, mathematician, philosopher, diplomat, and historian Gottfried Wilhelm Leibniz (1646, Leipzig–1716, Hannover). Derivatives lie at the basis of all calculations based on the continuity of space and time.

Indeed, the definition of velocity assumes that it makes sense to take the limit $\Delta t \rightarrow 0$, in other words, that infinitely small time intervals do exist in nature. The definition of velocity with derivatives is possible only because both space and time are described by sets which are *continuous*, or in mathematical language, *complete*. In the rest of our walk we should never forget that right from the beginning of classical physics, *infinities* are present in its description of nature. In fact, differential calculus can be defined as the study of infinity and its uses. We thus discover straight away that the appearance of infinity does not automatically render a description impossible or imprecise. (In fact, we will only use the smallest two of the various types of infinities. They and several other types are introduced in the intermezzo following this chapter.)

See page 431

The appearance of infinity in the usual description of motion was first criticized in his famous ironical arguments by Zeno of Elea (around 445 BCE), a disciple of Parmenides. In his well-known third argument, Zeno explains that since at every instant a given object occupies a part of space corresponding to its size, the notion of velocity at a given instant makes no sense; he provokingly concludes that therefore motion does not exist. Nowadays we would not call this an argument against the *existence* of motion, but against its usual *description*, in particular against the use of infinitely divisible space and time. (Do you agree?) However, the description criticized by Zeno actually works quite well in everyday life. The reason is simple but deep: changes in daily life are continuous. Large changes are made up of many small changes.

Ref. 31

This property of nature is not obvious. For example, we note that we have tacitly assumed that the path of an object is not a fractal nor some other badly behaved entity. Is this correct? For everyday life, it is. But the result does not apply in all domains of nature. In fact, Zeno will be partly rehabilitated later in our walk, and the more so the more we will proceed. For the moment though, we have no choice: we continue with the basic assumption that in nature changes happen smoothly.

Challenge 87

Why is velocity necessary as a concept? Aiming for precision in the description of motion, we need to find the complete list of aspects necessary to specify the state of an object. The concept of velocity is obviously a member of this list. Continuing in the same way, we

See page 675



Observation	acceleration
Centrifugal acceleration due to the earth's rotation	33 mm/s ²
Electron acceleration in household wire	ca. 50 mm/s ²
Gravitational acceleration on the moon	1.6 m/s ²
Gravitational acceleration on the earth's surface, depending on location	9.8 ± 0.1 m/s ²
Standard gravitational acceleration	9.806 65 m/s ²
Fastest car accelerated by wheels	ca. 15 m/s ²
Gravitational acceleration on Jupiter's surface	240 m/s ²
Acceleration of cheetah	ca. 32 m/s ²
Fastest leg acceleration (insects)	ca. 2 mm/s ²
Tennis ball against wall	ca. 0.1 Mm/s ²
Bullet acceleration in rifle	ca. 5 Mm/s ²
Fastest centrifuges	ca. 0.1 Gm/s ²
Acceleration of protons inside nucleus	ca. 10 ³¹ m/s ²
Highest possible acceleration in nature, $\sqrt{c^7/\hbar G}$	5.6 · 10 ⁵² m/s ²

Table 9 Some acceleration values found in nature

call *acceleration* \mathbf{a} of a body the change of velocity with time, or

$$\mathbf{a} = \frac{d\mathbf{v}}{dt} = \frac{d^2\mathbf{x}}{dt^2} . \quad (9)$$

Higher derivatives can also be defined in the same manner. They add little to the description of nature, as it turns out that neither they nor even acceleration itself are useful for the description of the state of motion of a system, as we will show shortly.*

Objects and point particles

Wenn ich den Gegenstand kenne, so kenne ich auch sämtliche Möglichkeiten seines Vorkommens in Sachverhalten.**

* Both velocity and acceleration have a magnitude and a direction, properties indicated by the use of **bold** letters for their abbreviations. Such physical quantities are called *vectors*. In more precise, mathematical language, a vector is an element of a set, called *vector space* V , in which the following properties hold for all vectors \mathbf{a} and \mathbf{b} and for all numbers c and d :

$$c(\mathbf{a} + \mathbf{b}) = c\mathbf{a} + c\mathbf{b} , \quad (c + d)\mathbf{a} = c\mathbf{a} + d\mathbf{a} , \quad (cd)\mathbf{a} = c(d\mathbf{a}) \quad \text{and} \quad 1\mathbf{a} = \mathbf{a} . \quad (10)$$

Challenge 104 Another example of vector space is the set of all *positions* of an object. Does the set of all rotations form a vector space? All vector spaces allow the definition of a unique null vector and of a single negative vector for each vector in it.

In many vector spaces the concept of *length* can be introduced, usually via an intermediate step. A vector space is called *Euclidean* if one can define for it a *scalar product* between two vectors, a number satisfying

$$\mathbf{a}\mathbf{a} \geq 0 , \quad \mathbf{a}\mathbf{b} = \mathbf{b}\mathbf{a} , \quad (\mathbf{a} + \mathbf{a}')\mathbf{b} = \mathbf{a}\mathbf{b} + \mathbf{a}'\mathbf{b} , \quad \mathbf{a}(\mathbf{b} + \mathbf{b}') = \mathbf{a}\mathbf{b} + \mathbf{a}\mathbf{b}' \quad \text{and} \quad (c\mathbf{a})\mathbf{b} = \mathbf{a}(c\mathbf{b}) = c(\mathbf{a}\mathbf{b}) . \quad (11)$$

In coordinate notation, the standard scalar product is given by the number $a_x b_x + a_y b_y + a_z b_z$. Whenever it vanishes the two vectors are *orthogonal*. The *length* or *norm* of a vector can then be defined as the square root of the scalar product of a vector with itself: $a = \sqrt{\mathbf{a}\mathbf{a}}$.

** If I know an object I also know all its possible occurrences in states of affairs.



Ludwig Wittgenstein, *Tractatus*, 2.0123

One aim of the study of motion is to find a complete and precise description of both states and objects. With help of the concept of space, the description of objects can be refined considerably. In particular, one knows from experience that all objects seen in daily life have an important property: they can be divided into *parts*. Often this observation is expressed by saying that all objects, or bodies, have two properties. First, they are made out of *matter*,* defined as that aspect of an object which is responsible for its impenetrability, i.e. the property preventing two objects from being in the same place. Secondly, bodies have a certain form or *shape*, defined as the precise way in which this impenetrability is distributed in space.

Challenge 121

In order to describe motion as accurately as possible, it is convenient to start with those bodies which are as simple as possible. In general, the smaller a body, the simpler it is. A body that is so small that its parts no longer need to be taken into account is called a *particle*. (The older term *corpuscule* has fallen out of fashion.) Particles are thus idealized little stones. The extreme case, a particle whose size is *negligible* compared to the dimensions of its motion, so that its position is described completely by a *single* triplet of coordinates, is called a *point particle* or a *mass point*. In equation (3), the stone was assumed to be such a point particle.

Do point-like objects, i.e. objects smaller than anything one can measure, exist in daily life? Yes, they do. The most notable examples are the stars. At present measure angular sizes as small as $2 \mu\text{rad}$ can be measured, a limit given by the fluctuations of the air in the atmosphere. In space, such as for the Hubble telescope orbiting the earth, the limit is due to the diameter of the telescope and is of the order of 10 nrad . Practically all stars seen from earth are smaller than that, and are thus effectively ‘point-like’, even when seen with the most powerful telescopes.

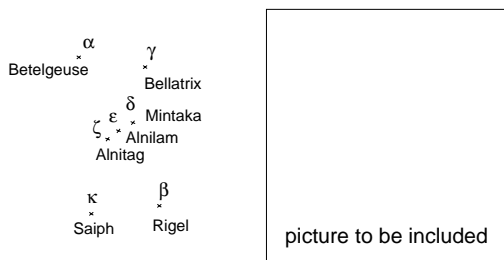

Figure 13 Betelgeuse

stars, of red giant type, can be measured with special instruments.** Mira in Cetus, Betelgeuse, the higher of the two shoulders of Orion, Antares in Scorpio, Aldebaran in Taurus,

One can even see the difference between ‘point-like’ sources and finite size ones with the naked eye alone: at night, stars twinkle, planets do not. (Check it!) This is due to the fact that the turbulence of air, which is responsible for the twinkling of stars by deflecting light rays by very small amounts, is too small to lead to twinkling of sources of larger size, like planets or satellites.

Challenge 138

In fact, the size of a few large and nearby

Ref. 33 * Matter is a word derived from the Latin ‘materia’, which originally meant ‘wood’ and was derived via intermediate steps from ‘mater’, meaning ‘mother’.

** The web site <http://www.astro.uiuc.edu/~kaler/sow/sowlist.html> gives an introduction to the different types of stars. The <http://www.astro.uiuc.edu/~dolan/constellations/constellations.html> web site provides detailed and interesting information about constellations.

For an overview of the planets, see the beautiful book by K.R. LANG, C.A. WHITNEY, *Vagabonds de l’espace – Exploration et découverte dans le système solaire*, Springer Verlag, 1993. The most beautiful pictures of the stars can be found in D. MALIN, *A view of the universe*, Sky Publishing and Cambridge University



and Sirius in Canis Major are examples of stars whose size has been measured; they are all only a few light years from earth. Of course, all other stars have a finite size as well, like the sun has, but one cannot prove this by measuring dimensions on pictures. (True?)

Ref. 34
Challenge 155

An object is *point-like for the naked eye* if its angular size is smaller than about $2' = 0.6$ mrad. Can you guess the size of a point-like dust particle? By the way, an object is *invisible* to the naked eye if it is point-like and if its luminosity, i.e. the intensity of the light from the object reaching the eye, is below some critical value. Can you estimate whether there are any man-made objects visible from the moon, or from the space shuttle?

Challenge 172

Challenge 189

The above definition of ‘point-like’ in everyday life is a fake one. Do proper point particles exist? In fact, is it possible at all to show that a particle has vanishing size? This question will be central in the last two parts of our walk. In fact we have also forgotten to ask and to check whether points in space do exist. Our walk will lead us to the astonishing result that all the answers to these questions are negative. Can you imagine how this could be proven? Do not be disappointed if you find this difficult; many brilliant minds has the same problem.

Challenge 206

However, many particles, such as electrons, quarks, or photons are point-like for all practical purposes. Once one knows how to describe the motion of point particles, the motion of extended bodies, rigid or deformable, can be described by assuming that they are made of parts, in the same way as the motion of an animal as a whole results from the motion of its various parts. The simplest description, the *continuum approximation*, describes extended bodies as an infinite collection of point particles. It allows to understand and to predict the motion of milk and honey, the motion of the air in hurricanes, and of perfume in rooms. Also the motion of fire and all other gaseous bodies, the bending of bamboo in the wind, the shape changes of chewing gum, and the growth of plants and animals can be described in this way.

Ref. 35

A better approximation than the continuum one is described shortly. Nevertheless, all observations have confirmed that the motion of large bodies can be described to high precision as the result of the motion of their parts. This approach will guide us through the first two parts of our mountain ascent. Only in the third part we will discover that at a fundamental scale, this decomposition cannot be possible.

Legs and wheels

Shape is an important aspect of bodies: among others, it allows us to count them. For example, one finds that living beings are always made of a single body. This is not an empty statement: from this fact one can deduce that animals cannot have wheels or propellers, but only legs, fins, or wings.

Why? Living beings have only one surface; simply put, they have only one piece of skin. Mathematically speaking, animals are *connected*. Thus in a first reaction one tends to imagine that the blood supply to a rotating part would get tangled up. But this argument is not correct, as Figure 14 shows. Can you find an example for this kind of motion in your own body? Are you able to see how many cables may be attached to the rotating body of the figure without hindering the rotation?

See Appendix D

Ref. 36

Challenge 223

Challenge 240

Press, 1993. Fascinating stories about what people do to take such pictures are told by P. MANLY, *Unusual telescopes*, Cambridge University Press, 1991.



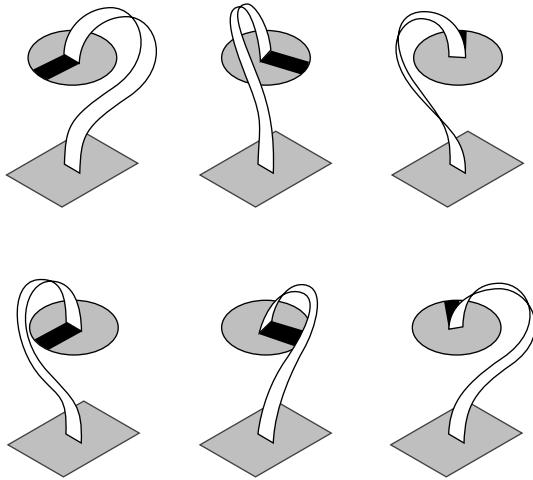

Figure 14 How an object can rotate without tangling up the connection to a second one

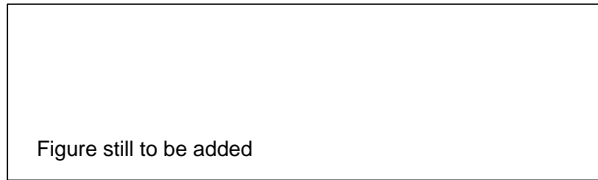

Figure 15 Legs and wheels in living beings

any change of shape of their components, thus enabling the use of wheels, propellers, or other rotating devices.*

However, like so many statements about living creatures, this one also has exceptions. The distinction between one and two bodies is poorly defined if the whole system has only a few molecules. This happens most clearly inside bacteria. Organisms such as *Escherichia coli*, the well-known bacterium found in the human gut, or bacteria from the *Salmonella* family, all swim using flagella. *Flagella* are thin filaments, similar to tiny hairs sticking out of the cell membrane. In the nineteen seventies it was shown that each flagellum, made of one or a few long molecules with a diameter of a few tens of nanometres, does in fact turn about its axis. A bacterium is able to turn its flagella in both clockwise and anticlockwise directions, can achieve more than a thousand turns per second, and can turn all its flagella in perfect synchronization. Therefore wheels actually do exist in living beings, albeit only tiny ones. But let us now continue with our study of simple objects.

* Despite the disadvantage of not being able to use rotating parts and being restricted to one piece only, nature's moving constructions, usually called animals, often outperform human built machines. As an example, compare the size of the smallest flying systems built by evolution with those built by humans. The discrepancy has two reasons. First of all, nature's systems have integrated repair and maintenance systems. Second, nature can build large structures inside containers with small openings. In fact, nature is very good at building sailing ships inside glass bottles. The human body is full of such examples; can you name a few?

Challenge 274

Despite this possibility, such a rotating part still cannot make a wheel. Can you see why? (Could it make a propeller?)

Challenge 257

In summary, whenever one observes a construction in which some part is turning continuously – and without the 'wiring' of the figure – one knows immediately that it is an artefact: a machine, not a living being, but built by one. Of course this does not rule out living bodies which move by rotation as a whole: the tumbleweed, seeds from various trees, some animals, children and dancers sometimes move by rotating as a whole.

Ref. 37

Single bodies, and thus all living beings, can only move through *deformation* of their shape: therefore they are limited to walking or running, to crawling, and to flapping wings or fins. In contrast, systems of several bodies, such as bicycles, pedal boats or other machines, can move without

See page 661

Ref. 38



Objects and images

In our walk through the forest here at the base of motion mountain, we observe two rather different types of motion: the breeze moves the leaves, and at the same time their shadows move on the ground. Both objects and images are able to move. Running tigers, falling snowflakes, and material ejected by volcanoes are examples of motion, as they change position over time. For the same reason, the shadow following our body, the beam of light circling the tower of a lighthouse on a misty night, and the rainbow that constantly keeps the same apparent distance from the hiker are examples of motion.

Everybody who has ever seen an animated cartoon in the cinema knows that images can move in more surprising ways than objects. Images can change their size, shape, and colour, a feat only few objects are able to perform. * Images can appear and disappear without trace, multiply, interpenetrate, go backwards in time, and defy gravity or any other force. Images, even usual shadows, can even move faster than light. Images can float in space and keep the same distance to approaching objects. Objects cannot do almost anything of this. In general, the ‘laws of cartoon physics’ are rather different from those in nature. In fact, the motion of images does not seem to follow any rules at all, in contrast to the motion of objects. Together, both objects and images differ from their environment in that they have *boundaries* defining their size and shape. We feel the need for precise criteria allowing the two cases to be distinguished.

The clearest distinction between images and objects is made with the same method that children or animals use when they stand in front of a mirror for the first time: they try to *touch* what they see. Indeed, if we are able to touch what we see – or more precisely, if we are able to move it – we call it an *object*, otherwise an *image*. ** One cannot touch images, but one can touch objects. And as everybody knows, touching something means to feel it resisting movement. Certain bodies, such as butterflies, pose little resistance and are moved with ease, others, such as ships, resist more, and are moved with more difficulty. This resistance to motion – more precisely, to change of motion – is called *inertia*, and the difficulty with which a body can be moved is called its (*inertial*) *mass*. Images have neither inertia nor mass.

Summing up, for the description of motion one must distinguish bodies, which can be touched and are impenetrable, from images, which cannot and are not. Everything visible is either an object or an image; there is no third possibility. If the object is so far away that it cannot be touched, such as a star or a comet, it can be difficult to decide whether one is dealing with an image or an object; we will encounter this difficulty repeatedly. For example, how would you show that comets are objects and not images?

* Excluding very slow changes such as the change of colour of leaves in the fall, in nature only certain crystals, the octopus, the chameleon and a few other animals achieve this. Of human made objects, television, computer displays, heated objects, and certain lasers can do it. Do you know more examples? An excellent source of information on the topic of colour is the book by K. NASSAU, *The physics and chemistry of colour – the fifteen causes of colour*, J. Wiley & Sons, 1983. In the popular science domain, the most beautiful book is the classic work by the flemish astronomer MARCEL G.J. MINNAERT, *Light and colour in the outdoors*, Springer, 1993, an updated version based on his wonderful book series, *De natuurkunde van ‘t vrije veld*, Thieme & Cie, Zutphen. It is a must for all natural scientists.

** One could imagine to include the requirement that objects may be rotated; however, it gives difficulties in the case of atoms, as explained on page 513, and with elementary particles.



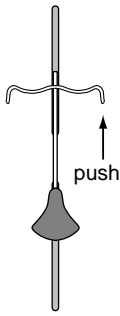

Figure 16 In which direction does the bicycle turn?

Moving images are made of *radiation* in the same way that objects are made of *matter*. Images are the domain of shadow theatre, cinema, television, computer graphics, belief systems and drug experts: photographs, motion pictures, ghosts, angels, dreams, and many hallucinations are images. To understand images, we need to study radiation; but due to the importance of objects – after all we are objects ourselves – we will study them first.

Ref. 41

Motion and contact

When a child learns to ride a monocycle, she or he makes use of a general rule in our world: one body acting on another puts it in motion. In about six hours, anybody can learn to ride and enjoy it. In all of life's pleasures, such as toys, animals, women, machines, children, men, the sea, wind, cinema, juggling, rambling, and loving, something pushes something else. Thus the first challenge is to describe this transfer of motion in more precise terms.

But contact is not the only way to put something into motion; a counter-example is an apple falling from a tree or a magnet pulling another. Non-contact influences are more fascinating: nothing is hidden, but nevertheless something mysterious happens. Contact motion seems easier to grasp, and that is why one usually starts with it. However, we will soon find out that taking this choice one makes a similar experience that bicycle riders make. When riding a bicycle at sustained speed and trying to turn left by pushing the right side of the steering bar, one takes a *right turn*.* In other words, despite our choice the rest of our walk will rapidly force us to study non-contact interactions as well.

What is mass?

Δός μοι ποῦ στῶ καὶ κινῶ τὴν γῆν.
Da ubi consistam, et terram movebo.**
Archimedes (ca. 283–212), as cited by Pappus.

Ref. 42

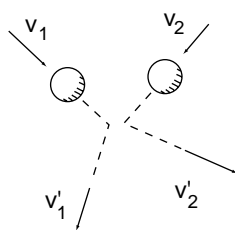

Figure 17 Collisions define mass

When we push something we do not know, such as when we kick some object on the street, we automatically pay attention to the same two aspects that children explore when before a mirror for the first time, or when they see a red laser spot for the first time. We all check how much the unknown entity can be pushed, and how much the unknown object moves. Higher precision is possible with experiments like the one shown in Figure 17. Repeating the experiment with various pairs of objects, one notes that one can ascribe a fixed quantity m_i to every object i . These quantities are determined by the relation

$$\frac{m_2}{m_1} = -\frac{\Delta v_1}{\Delta v_2} \quad (12)$$

- Challenge 342 * This surprising effect obviously works only above a certain minimal speed. Can you determine which one? Be careful! Too strong a push will make you fall.
** Give me a place to stand, and I'll move the earth.



where Δv is the velocity change produced by the collision. The number m_i is called the *mass* of the object.

In order to get mass values common to everybody, the mass of one particular, selected object has to be fixed in advance. This special object is called the *standard kilogram* and is kept with great care under vacuum in a glass container near Paris. It is touched only once every few years because otherwise dust, humidity or scratches would change its mass. Through the standard kilogram the value of the mass of every other object in the world is determined.

The mass thus measures the difficulty of getting something moving. High masses are harder to move than low masses. Obviously, only objects have mass; images don't. (By the way, the word 'mass' is derived, via Latin, from the Greek $\mu\alpha\zeta\alpha$, bread, or the Hebrew 'mazza', unleavened bread – quite a change in meaning.)

Ref. 33

Experiments also show the important result that throughout any collision, the sum of all masses is conserved:

$$\sum_i m_i = \text{const} \quad . \quad (13)$$

Therefore the mass of a composite systems is the sum of the mass of the components. In short, *Galilean mass is a measure for the quantity of matter*.

The definition of mass can also be given in another way. We can ascribe a number m_i to every object i such that for collisions free of outside interference the following sum is unchanged *throughout* the collision:

$$\sum_i m_i \mathbf{v}_i = \text{const} \quad . \quad (14)$$

The product of the velocity \mathbf{v}_i and the mass m_i is called the *momentum* of the body. The sum, or *total momentum* of the system, is the same before and after the collision; it is a *conserved* quantity. The two conservation principles (13) and (14) were first stated in this way by the important Dutch physicist Christiaan Huygens.*

As a consequence, if a moving sphere hits a resting one of the same mass, a simple rule determines the angle between the directions the two spheres take after the collision. Can you find this rule? It is quite useful when playing billiards?

Challenge 359

Challenge 376

Another consequence was shown on the cover photograph of the CERN Courier in 1994. It showed a man lying on a bed of nails with two large blocks of concrete on his stomach. Another man is hitting the concrete with a heavy sledgehammer. As the impact is mostly absorbed by the concrete, there is no pain and no danger – except if the concrete is missed...

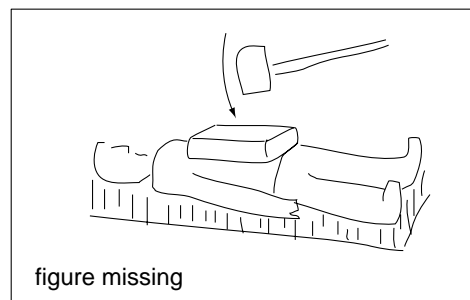

Figure 18 Is this dangerous?

* Christiaan Huygens (1629, 's Gravenhage –1695, Hofwyck) was one of the main physicists of his time; he clarified the concepts of mechanics; he also was one of the first to show that light is a wave.



The above definition of mass has been generalized by the physicist and philosopher Ernst Mach* in such a way that it is valid even if the two objects interact without contact, as long as they do so along the line connecting their positions. The mass ratio between two bodies is defined as negative acceleration ratio, thus as

$$\frac{m_2}{m_1} = -\frac{a_1}{a_2} \quad , \quad (15)$$

where a is the acceleration of each body during the interaction. This definition has been studied in much detail in the physics community, mainly in the nineteenth century. A few points sum up the results:

- The definition of mass *implies* the conservation of momentum $\sum mv$. Momentum conservation is *not* a separate principle. Conservation of momentum cannot be checked experimentally, because mass is defined in such a way that it holds.
- The definition of mass *implies* the equality of the products $m_1 a_1$ and $-m_2 a_2$. Such products are called *forces*. The equality of acting and reacting forces is not a separate principle; mass is defined in such a way that it holds.
- The definition of mass is *independent* of whether contact is involved or not, and whether the origin of the accelerations is due to electricity, gravitation, or other interactions.**
- The definition is valid only for observers at rest or in inertial motion. More about this issue later on.

By measuring masses of the bodies around us, we discover its main properties. Mass is *additive* in everyday life,, as the mass of two bodies combined is equal to the sum of the two separate masses. Furthermore, mass is *continuous*; it can seemingly take any positive value. Finally, mass is *conserved*; the mass of a system, defined as the sum of the mass of all constituents, does not change over time if the system is kept isolated from the rest of the world. Mass is conserved not only in collisions alone: also during melting, evaporation, digestion, and all other processes mass does not appear or disappear.

Later we will find that also in the case of mass all these properties are only approximate. Precise experiments show that none of them are correct.*** For the moment we continue with the present, Galilean concept of mass, as we have no better one at our disposal.

In a famous experiment in the 19th century, for several weeks a man lived with all his food and drink supply, and inclusive his toilet, on a large weighing balance. How did the measured value change with time?

Challenge 410

The definition of mass implies that during the fall of an object, the earth is accelerated upwards by a tiny amount. If one could measure this tiny amount, one could determine the

* Ernst Mach (1838, Chrlice–1916), Austrian physicist and philosopher. The *mach* unit for aeroplane speed as a multiple of the speed of sound in air (about 0.3 km/s) is named after him. He developed the so-called Mach-Zehnder interferometer; he also studied the basis of mechanics. His thoughts about mass and inertia influenced the development of general relativity, and led to Mach's principle, which we will discuss later on. He was also proud to be the last scientist denying – humorously, and against all evidence – the existence of atoms.

** As mentioned above, only *central* forces obey the relation (15) used to define mass. Central forces act between the centre of mass of bodies. We give a precise definition later on. But since all fundamental forces are central, this is not a restriction. There seems to be one notable exception: magnetism. Is the definition of mass valid in this case?

*** In particular, in order to define mass we must be able to *distinguish* bodies. This seems a trivial requirement, but we discover that this is not always possible in nature.

See page 68

Challenge 393



Mass values	Physical property	Mathematical name (see later for definitions)
can be distinguished	distinguishability	set
can be ordered	sequence	order
can change gradually	continuity	completeness
can be added	quantity of matter	additivity
do not change	conservation	invariance
do not disappear	impenetrability	positivity

Table 10 Properties of Galilean mass

Observation	Mass
Mass increase through absorption of one green photon	$3.7 \cdot 10^{-36} \text{ kg}$
Lightest known object: electron	$9.1 \cdot 10^{-31} \text{ kg}$
Atom of argon	$39.962\,383\,123(3) \text{ u} = 66.359\,1 \text{ yg}$
Human at early age	10^{-11} kg
Water adsorbed onto a kilogram metal weight	ca. 10^{-8} kg
Planck mass	$2.2 \cdot 10^{-8} \text{ kg}$
Fingerprint	ca. 10^{-7} kg
Typical ant	ca. 10^{-7} kg
Water droplet	ca. 10^{-6} kg
Honey bee	$1 \cdot 10^{-4} \text{ kg}$
Largest living being	ca. 10^6 kg
Largest ocean going ship	ca. $400 \cdot 10^6 \text{ kg}$
Largest object moved by man (Troll gas rig)	$687.5 \cdot 10^6 \text{ kg}$
Large antarctic iceberg	10^{15} kg
Water on earth	10^{21} kg
Solar mass	$2.0 \cdot 10^{30} \text{ kg}$
Our galaxy	ca. 10^{41} kg
Total mass visible in the universe	ca. 10^{54} kg

Table 11 Some mass values

Challenge 427 mass of the earth. Unfortunately, this measurement is impossible. Can you find a better way to determine the weight of the earth?

In summary, the mass of a body is thus most precisely described by a *positive* real number, often abbreviated m or M . This is a direct consequence of the impenetrability of matter. Indeed, a *negative* (inertial) mass would mean that such a body would move in the opposite direction of any applied force or acceleration. Such a body could not be kept in a box; it would break through any wall trying to stop it. Strangely enough, negative mass bodies would still fall downwards in the field of a large positive mass (though slower than an equivalent positive mass). Are you able to confirm this? However, a small positive mass object would float away from a large negative mass body, as you can easily deduce by comparing the various accelerations involved. A positive and a negative mass of the same value would



stay at constant distance and spontaneously accelerate away along the line connecting the two masses. Note that both energy and momentum are conserved in all these situations.* Negative-mass bodies have never been observed. Antimatter, which will be discussed later, also has positive mass.

See page 194
and 511

Is motion eternal?

Every body continues in the state of rest or of uniform motion in a straight line except in so far as it doesn't.
Arthur Eddington (1882–1944), British astrophysicist.

Using the definition of mass, the product $\mathbf{p} = m\mathbf{v}$ is called the *momentum* of a particle; it describes the tendency of an object to keep moving during collisions. The bigger it is, the harder it is to stop the object. Like velocity, momentum has a direction and a magnitude: it is a vector. (In French, momentum is called ‘quantity of motion’, a more appropriate term. In the old days, the term ‘motion’ was used instead of ‘momentum’, by Newton, for example.) Relation (14), the conservation of momentum, therefore expresses the conservation of motion during interactions.

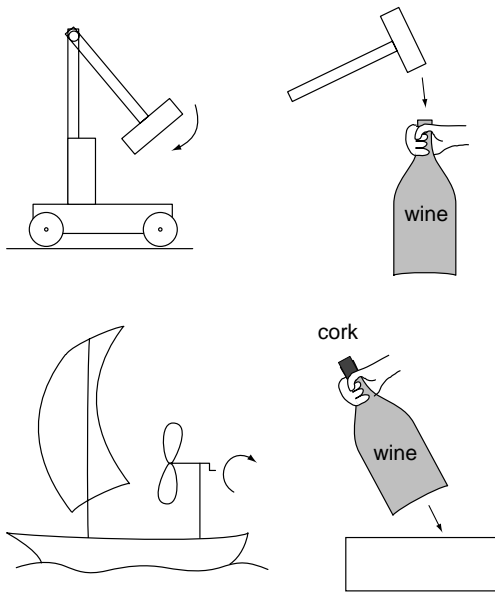

Figure 19 What happens?

The conservation of momentum and mass also means that teleportation (‘beam me up’) is impossible in nature. Can you explain this to a child?

Challenge 512

Challenge 529

* For more curiosities, see R.H. PRICE, *Negative mass can be positively amusing*, American Journal of Physics **61**, pp. 216–217, 1993. Negative mass particles in a box would heat up a box made of positive mass while traversing its walls, and accelerating, i.e. losing energy, at the same time. They would allow building of a perpetual mobile of the second kind, i.e. a device circumventing the second principle of thermodynamics. Moreover, such a system would have no thermodynamical equilibrium, because its energy could decrease forever. The more one thinks about negative mass, the more one finds strange properties contradicting observations.

Challenge 478

Challenge 495

By the way, what is the range of possible mass values for tachyons?



Momentum conservation implies that motion never stops; it is only *exchanged*. On the other hand, motion often disappears in our environment, as in the case of a stone dropped to the ground, or of a ball left rolling on grass. Moreover, in daily life we often observe creation of motion, such as every time we open a hand. How do these examples fit with the conservation of momentum?

It turns out that the answer lies in the microscopic aspects of these systems. A muscle only *transforms* one type of motion, namely that of the electrons in certain chemical compounds* into another, the motion of the fingers. The working of muscles is similar to that of a car engine transforming the motion of electrons in the fuel into motion of the wheels. Both systems need fuel and get warm in the process.

We must also study the microscopic behaviour when a ball rolls on grass until it stops. The disappearance of motion is called *friction*. Studying the situation carefully, one finds that the grass and the ball heat up a little during this process. During friction, visible motion is transformed into heat. Later, when we discover the structure of matter, it will become clear that heat is the disorganized motion of the microscopic constituents of every material. When these constituents all move in the same direction, the object as a whole moves; when they oscillate randomly, the object is at rest, but is warm. Heat is a form of motion. Friction thus only seems to be disappearance of motion; in fact it is a transformation of ordered into unordered motion.

Despite momentum conservation, *macroscopic* perpetual motion does not exist, since friction cannot be eliminated completely.** Motion is eternal only at the microscopic scale. The disappearance and also the spontaneous appearance of motion in everyday life is an illusion, due to the limitations of our senses. For example, the motion proper to every living being exists before its birth, and stays after its death. The same happens with its energy. This is probably the closest one can get to the idea of everlasting life from evidence collected by observation. It is perhaps less than a coincidence that energy used to be called ‘vis viva’, or living force, by Leibniz and many others.

Since motion is conserved, it has no origin. Therefore, at this stage of our walk we cannot at all answer the fundamental questions: Why does motion exist? What is its origin? The end of our adventure is nowhere near.

Ref. 43 * Usually adenosinetriphosphate (ATP), the fuel of most processes in animals

** Some funny examples of past attempts to build a *perpetual motion machine* are described in STANISLAV MICHEL, *Perpetuum mobile*, VDI Verlag, 1976. Interestingly, the idea of eternal motion came to Europe from India, via the Islamic world, around the year 1200, and became popular as it opposed the then standard view that all motion on earth disappears over time. See also the www.geocities.com/mercutio78_99/pmm.html web site. The conceptual mistake made by all eccentrics and used by all crooks is always the same: the hope of overcoming friction.

Ref. 44 If the machine is well constructed, i.e. with little friction, it can take the little energy it needs for the sustenance of its motion from very subtle environmental effects. For example, in the Victoria and Albert Museum in London one can admire a beautiful clock powered by the variations of air pressure over time.

Challenge 546 Small friction means that motion takes a long time to stop. One immediately thinks of the motion of the planets. In fact, there *is* friction between the earth and the sun. (Can you guess one of the mechanisms?) But the value is so small that the earth has already circled around the sun for thousands of millions of years, and will do so for quite some time.



More on conservation

When collisions are studied even more, a second conserved quantity turns up. Experiments show that in the case of perfect, or elastic collisions – collisions without friction – the following quantity, called the *kinetic energy* T of the system, is also conserved:

$$T = \sum_i \frac{1}{2} m_i \mathbf{v}_i^2 = \text{const} \quad . \quad (16)$$

The factor 1/2 and the name ‘kinetic energy’ were introduced by the French engineer and mathematician Gustave-Gaspard Coriolis (Paris, 1792– Paris, 1843) so that the relation $dT/dv = p$ would be obeyed. (Why?) Energy is a word taken from ancient Greek; originally it was used to describe character, and meant ‘intellectual or moral vigour’. It was taken into physics by William Thomson and William Rankine around 1860 because its literal meaning is ‘force within.’

Challenge 563

Physical energy measures the ability to generate motion. A body has a lot of energy if it has the ability to move many other bodies. Energy is a number; it has no direction. The total momentum of two equal masses moving with opposite velocities is zero; the total energy depends on the velocity values. Energy thus also measures motion, but in a different way than momentum does. Energy measures motion in a more global way.

Do not be surprised if you do not grasp the difference between momentum and energy straight away: physicists took about two centuries to figure it out. For some time they even insisted on using the same word for both of them, and often they didn’t know which situation required which concept. So you are allowed take a few minutes to think about the topic.

Both quantities measure how systems change. Momentum tells how systems change over distance, energy measures how systems change over time. Momentum is needed to compare motion here and there. Energy is needed to compare motion now and later.

One way to express the difference between energy and momentum is to think about the following challenges. Is it more difficult to stop a running man with mass m and speed v , or one with mass $m/2$ and speed $2v$, or one with mass $m/2$ and speed $\sqrt{2}v$? You may want to ask a rugby-playing friend for confirmation.

Challenge 580

Another distinction is taught by athletics: the *real* long jump world record, almost 10 m is still kept by an athlete who in the early 20th century ran with two weights in his hands, and then threw the weights behind him in the moment he took off. Can you explain the feat?

Challenge 597

When a car travelling at 100 m/s runs frontally into a parked car of the same make, which car has the larger damage? What changes if the parked car has its brakes on?

Challenge 614

To get a better feeling for energy, here is an additional way. The world use of energy by human machines (coming from solar, geothermal, biomass, wind, nuclear, hydro, gas, oil, coal, or animals sources) in the year 2000 is about 420 EJ, for a world population of about 6000 million people. To see what this energy consumption means, translate it into a personal power consumption; one gets about 2.2 kW. The Watt W is the unit of power, and is simply defined as 1 J/s, reflecting the definition of (*physical*) *power* as energy per time. As a working person can produce mechanical work for about 100 W, the average human energy consumption corresponds to about 22 humans working 24 hours a day. In particular, if one looks at the energy consumption in countries of the first world, the average inhabitant there has machines working for him equivalent to several hundred ‘servants’. Can you point out some of these machines?

Ref. 45

Challenge 631



Observation	Power
Power of flagellar motor in bacterium	...
Incandescent light bulb light output	1 to 5 W
Incandescent light bulb electricity consumption	25 to 100 W
A human, during one work shift	ca. 100 W
One horse, for one shift	ca. 300 W
Eddy Merckx, the great bicycle athlete, during one hour	ca. 500 W
Official horse power	ca. 735 W
Large motor bike	100 kW
Electrical power station	100 to 6000 MW
World's electrical power production in 2000	450 GW
Input on earth surface: sun's irradiation of earth Ref. 46	0.17 EW
Input on earth surface: thermal energy from inside of earth	32 TW
Input on earth surface: power from tides (i.e. from earth's rotation)	3 TW
Input on earth surface: power generated by man from fossil fuels	8 to 11 TW
Lost from earth surface: power stored by plants' photosynthesis	40 TW
Output of earth surface: sunlight reflected into space	0.06 EW
Output of earth surface: power radiated into space at 287 K	0.11 EW
Sun's output	384.6 YW

Table 12 Some power measurements

Kinetic energy is thus not conserved in everyday life. For example, in non-elastic collisions, like that of a chewing gum and a wall, kinetic energy is lost. *Friction* destroys kinetic energy, as it destroys momentum. At the same time, friction produces heat. It was one of the important conceptual discoveries of physics that *total* energy is conserved if one includes the discovery that heat is a form of energy. Friction is thus in fact a process transforming kinetic energy, i.e. the energy connected with the motion of a body, into heat. On a microscopic scale, energy is conserved.* Indeed, without energy conservation, the concept of time would not be definable. We will show this connection shortly.

Rotation

Rotation keeps us alive. Without the change of day and night, we would be either fried or frozen to death, depending on our location on our planet. A short summary of rotation is thus appropriate. We saw before that a body is described by its reluctance to move; similarly, a body also has a reluctance to turn. This quantity is called its *moment of inertia*, and is often abbreviated Θ . The speed or rate of rotation is described by *angular velocity*, usually abbreviated ω . Like mass, the moment of inertia is defined in such a way that the sum of *angular momenta* L – the product of moment of inertia and angular velocity – is conserved

* In fact, the conservation of energy was stated in its modern form only in 1842, by Julius Robert Mayer. He was a medical doctor by training, and the journal 'Annalen der Physik' refused to publish his paper, as it supposedly contained 'fundamental errors.' What the editors called errors were in fact the contradictions with their prejudices. Later on, Helmholtz, Kelvin, Joule, and many others acknowledged Mayer's genius. Today, energy conservation is one of the pillars of physics, as it is valid in all its domains.



Quantity	Linear motion		Rotation	
State	time	t	time	t
	position	x	angle	φ
	momentum	$p = mv$	angular momentum	$L = \Theta\omega$
	energy	$mv^2/2$	energy	$\Theta\omega^2/2$
Motion	velocity	v	angular velocity	ω
	acceleration	a	angular acceleration	α
Reluctance to move	mass	m	moment of inertia	Θ
Motion change	force	ma	torque	$\Theta\alpha$

Table 13 Correspondence between linear and rotational motion

in systems which do not interact with the outside world:

$$\sum_i \Theta_i \omega_i = \sum_i L_i = \text{const} \quad (17)$$

The moment of inertia can be related to the mass and shape of a body; the resulting expression is

$$\Theta = \sum_n m_n r_n^2, \quad (18)$$

where r_n is the distance from the mass element m_n to the axis of rotation. Can you confirm the expression? Therefore, the moment of inertia of a body depends on the chosen axis of rotation. Challenge 648

Obviously, the value of the angular momentum also depends on the location of the axis used for its definition. For each axis direction, one distinguishes *intrinsic* angular momentum, when the axis goes through the centre of mass of the body, from *extrinsic* angular momentum, when it does not.* (By the way, the *centre of mass* of a body is that imaginary point which moves straight during vertical fall, even if the body is rotating. Can you find a way to determine its locations for a specific body?) Challenge 682

Every object which has an orientation also has an intrinsic angular momentum. (What about a sphere?) Therefore, point particles do not have intrinsic angular momenta – at least in first approximation. (This conclusion will change in quantum theory.) The *extrinsic* angular momentum of a point particle is given by Challenge 699

$$\mathbf{L} = \mathbf{r} \times \mathbf{p} = \frac{2\mathbf{A}(T)m}{T} \quad \text{so that} \quad L = r p = \frac{2A(T)m}{T} \quad (20)$$

where $\mathbf{A}(T)$ is the surface swept by the position vector of the particle during time T .** The angular momentum thus points along the rotation axis, following the right hand rule.

* Extrinsic and intrinsic angular momenta are related by

$$\Theta_{\text{ext}} = \Theta_{\text{int}} + md^2, \quad (19)$$

where d is the distance between the centre of mass and the axis of extrinsic rotation. This relation is called *Steiner's parallel axis theorem*. Are you able to deduce it? Challenge 665

** For the curious, the result of the *cross product* or *vector product* $\mathbf{a} \times \mathbf{b}$ between two vectors \mathbf{a} and \mathbf{b} is defined as that vector which is orthogonal to both, whose orientation is given by the *right hand rule*, and whose length



Observation	Angular velocity
Galactic rotation	$= 2\pi / 220\,000\,000 \text{ a}$
Average sun rotation around its axis	ca. $2\pi \cdot 3.8 \cdot 10^{-7} / \text{s} = 2\pi / 30 \text{ d}$
Typical lighthouse	ca. $2\pi \cdot 0.08 / \text{s}$
Jumping ballet dancer	ca. $2\pi \cdot 3 / \text{s}$
Ship's diesel engine	$2\pi \cdot 5 / \text{s}$
Washing machine	up to $2\pi \cdot 20 / \text{s}$
Bacterial flagella	ca. $2\pi \cdot 100 / \text{s}$
Racing car engine	up to $2\pi \cdot 600 / \text{s}$
Fastest turbine built	ca. $2\pi \cdot 10^3 / \text{s}$
Fastest pulsars (rotating stars)	up to $2\pi \cdot 10^3 / \text{s}$
Proton rotation	ca. $2\pi \cdot 10^{20} / \text{s}$
Highest possible, Planck angular velocity	ca. $2\pi \cdot 10^{35} / \text{s}$

Table 14 Some rotation speeds

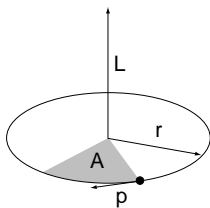

Figure 20 Angular momentum

We then define a corresponding *rotational energy* as

$$E_{\text{rot}} = \frac{1}{2} \Theta \omega^2 = \frac{L^2}{2\Theta} . \tag{22}$$

Challenge 750 Can you guess how much larger the rotational energy of the earth is compared with the yearly electricity usage of humanity? If you can find a way to harness this energy, you will become famous.

As in the case of linear motion, rotational energy and angular momentum are not always conserved in the macroscopic world, due to friction; but they are always conserved on the microscopic scale.

Challenge 716 is given by $ab \sin \angle(\mathbf{a}, \mathbf{b})$, i.e. by the surface area of the parallelogram spanned by the two vectors. From the definition you can show that the vector product has the properties

$$\begin{aligned} \mathbf{a} \times \mathbf{b} &= -\mathbf{b} \times \mathbf{a} \quad , \quad \mathbf{a} \times (\mathbf{b} + \mathbf{c}) = \mathbf{a} \times \mathbf{b} + \mathbf{a} \times \mathbf{c} \quad , \quad \lambda \mathbf{a} \times \mathbf{b} = \lambda(\mathbf{a} \times \mathbf{b}) = \mathbf{a} \times \lambda \mathbf{b} \quad , \quad \mathbf{a} \times \mathbf{a} = \mathbf{0} \quad , \\ \mathbf{a}(\mathbf{b} \times \mathbf{c}) &= \mathbf{b}(\mathbf{c} \times \mathbf{a}) = \mathbf{c}(\mathbf{a} \times \mathbf{b}) \quad , \quad \mathbf{a} \times (\mathbf{b} \times \mathbf{c}) = \mathbf{b}(\mathbf{a} \cdot \mathbf{c}) - \mathbf{c}(\mathbf{a} \cdot \mathbf{b}) \quad , \\ (\mathbf{a} \times \mathbf{b})(\mathbf{c} \times \mathbf{d}) &= \mathbf{a}(\mathbf{b} \times (\mathbf{c} \times \mathbf{d})) = (\mathbf{a} \cdot \mathbf{c})(\mathbf{b} \cdot \mathbf{d}) - (\mathbf{b} \cdot \mathbf{c})(\mathbf{a} \cdot \mathbf{d}) \quad , \\ (\mathbf{a} \times \mathbf{b}) \times (\mathbf{c} \times \mathbf{d}) &= \mathbf{c}((\mathbf{a} \times \mathbf{b}) \cdot \mathbf{d}) - \mathbf{d}((\mathbf{a} \times \mathbf{b}) \cdot \mathbf{c}) \quad , \quad \mathbf{a} \times (\mathbf{b} \times \mathbf{c}) + \mathbf{b} \times (\mathbf{c} \times \mathbf{a}) + \mathbf{c} \times (\mathbf{a} \times \mathbf{b}) = \mathbf{0} \quad . \end{aligned} \tag{21}$$

See page 849 Challenge 733 The vector product exists (almost) only in three-dimensional vector spaces. (See Appendix D) The cross product vanishes if and only if the vectors are parallel. The parallelepiped spanned by three vectors \mathbf{a} , \mathbf{b} and \mathbf{c} has the volume $V = \mathbf{c}(\mathbf{a} \times \mathbf{b})$. The pyramid or tetrahedron formed by the three vectors has one sixth of that volume.



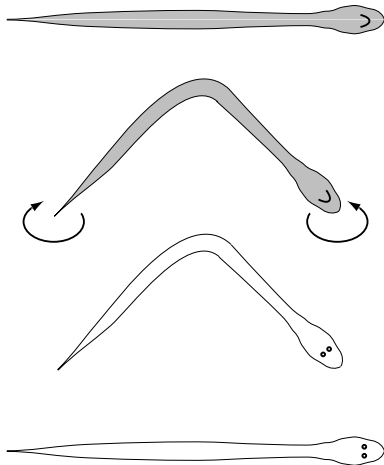

Figure 21 How a snake turns itself around its axis

Figure 21 shows. During the Olympic games one can watch board divers and gymnasts perform similar tricks. Rotation is thus different from translation in this aspect. Why?

On a frictionless surface, as approximated by smooth ice or by a marble floor covered by a layer of oil, it is impossible to move forward. In order to move, we need to push *against* something. Is this also the case for rotation?

Surprisingly, it is possible to turn even *without* pushing against something. You can check this on a well-oiled rotating office chair: simply rotate an arm above the head. After each turn of the hand, the orientation of the chair has changed by a small amount. Indeed, conservation of angular momentum and of rotational energy do not prevent bodies from changing their orientation. Cats learn this in their youth; after they learned the trick, if they are dropped legs up, they can turn themselves in such a way that they always land feet first.

Ref. 47

Also snakes know how to rotate themselves, as Fig-

Challenge 767

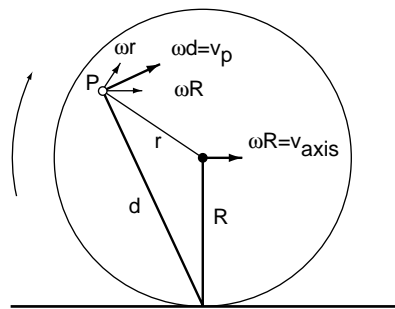

Figure 22 The velocities and unit vectors for a rolling wheel

Rolling wheels

Rotation is an interesting phenomenon. A rolling wheel does *not* turn around its axis, but around its point of contact. Let us show this.

A wheel of radius R is *rolling* if the speed of the axis v_{axis} is related to the angular velocity by

$$\omega = \frac{v_{\text{axis}}}{R} . \quad (23)$$

For any point P on the wheel, with distance r from the axis, the velocity v_P is the sum of the motion of the axis and the motion around the axis. Figure 22 shows that v_P is orthogonal to d , the distance between the point P and the contact point of the wheel. The figure also shows that the length ratio between v_P and d is the same as between v_{axis} and R . As a result, we can write

$$\mathbf{v}_P = \boldsymbol{\omega} \times \mathbf{d} \quad (24)$$

which shows that a rolling wheel does indeed rotate about its contact point with the ground.

Surprisingly, when a wheel rolls, some points on it move towards the wheel's axis, some stay at fixed distance, and others move away from it. Can you determine where these various points are located? Together, they lead to interesting pictures when a rolling wheel with spokes, such as a bicycle wheel, is photographed.

Challenge 784

Challenge 801

Ref. 48



How do we walk?

Golf is a good walk spoiled.
Mark Twain

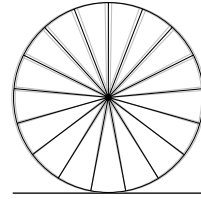

Figure 23 A simulated photograph of a rolling wheel with spokes

Ref. 10

Why do we move our arms when walking or running? To conserve energy. In fact, when a body movement is performed with as little energy as possible, it is natural and graceful. (This can indeed be taken as the actual definition of grace. The connection is common knowledge in the world of dance; it is also a central aspect of the methods used by actors to learn how to move their bodies as beautifully as possible.)

To convince yourself about the energy savings, try walking or running with your arms fixed or moving in the opposite direction than usual: the effort is considerably higher. In fact, when a leg is moved, it produces a torque around the body axis which has to be counter-balanced. The method using the least energy is the swinging of arms. Since the arms are lighter than the legs, to compensate for the momentum, they must move further from the axis of the body; evolution has therefore moved the attachment of the arms, the shoulders, farther away than those of the legs, the hips. Animals on two legs but without arms, such as penguins or pigeons, have more difficulty walking; they have to move their whole torso with every step.

Ref. 49

Which muscles do most of the work when walking, the motion which experts call *gait*? In 1980, Serge Gracovetsky found that in human gait most power comes from the *spine* muscles, not from the legs. (Note that people without legs are also able to walk.) When you take a step, the lumbar muscles straighten the spine; this automatically makes it turn a bit to one side, so that the knee of the leg on that side automatically comes forward. When the foot is moved, the lumbar muscles can relax, and then straighten again for the next step. In fact, one can experience the increase in tension in the *back* muscles

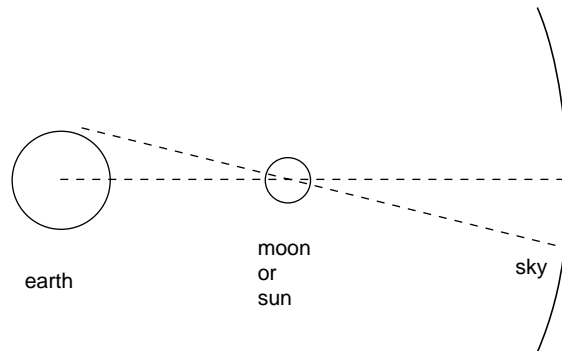

Figure 24 The parallax - obviously not drawn to scale

Challenge 818

when walking without moving the arms, thus confirming where the human engine is located.



Is the earth rotating?

Eppur si muove!*

The search for answers to this question gives a beautiful cross-section of the history of classical physics. Already around the year 265 BCE, the Greek thinker Aristarchos of Samos maintained that the earth rotates. He had measured the parallax of the moon (today known to be up to 0.95 degrees) and of the sun (today known to be 8.8'). The *parallax* is an interesting effect; it is the angle describing the difference between the directions of a body in the sky when seen by an observer on the surface of the earth and when seen by a hypothetical observer at its centre. Aristarchos noticed that the moon and the sun wobble across the sky, and this wobble has a period of 24 hours. He concluded that the earth rotates.

Ref. 50

Measurements of the the aberration of light also show the rotation of the earth; it can be detected with telescopes while looking at the stars. The *aberration* is a change of the expected light direction which we will discuss shortly. At the equator, earth rotation adds an angular deviation of 0.32', changing sign every 12 hours, to the aberration due to the motion of the earth around the sun, about 20.5'. In modern times, astronomers had found a number of additional proofs, but none was accessible to the man on the street.

See page 168

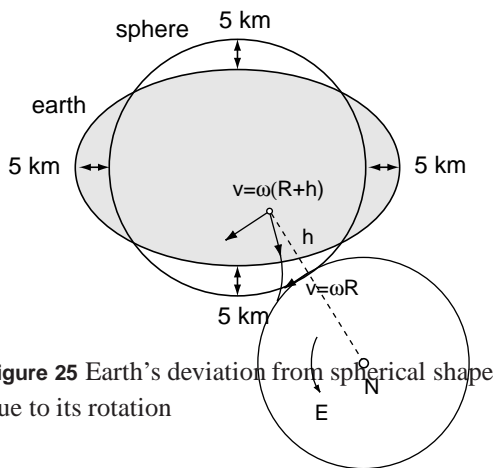

Figure 25 Earth's deviation from spherical shape due to its rotation

Also the measurements showing that the earth was not a sphere, but was *flattened* at the poles, showed the rotation of the earth. Again however, this result from the 17th century is not accessible to direct observation.

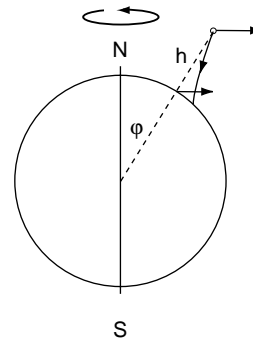

Figure 26 The deviations of free fall towards the east and towards the equator, both due to the rotation of the earth

Then, in the years 1790 to 1792 in Bologna, Giovanni Battista Guglielmini (1763–1817) finally succeeded to measure what Galileo and Newton had predicted to be the simplest proof for the earth's rotation. On the earth, objects do not fall vertically,

* 'And yet she moves' is the sentence falsely attributed to Galileo about the earth; true is that in his trial he was forced to publicly retract the idea of a moving earth to save his life (see also the footnote on page 142).



but are slightly deviated to the east. This deviation appears because an object keeps the larger horizontal velocity it had at the height from which it started falling, as shown in Figure 26. Guglielmini's result was the first non-astronomical proof of the earth's rotation. The experiments were repeated in 1802 by Johann Friedrich Benzenberg (1777–1846). Using metal balls which he dropped from the Michaelis tower in Hamburg – a height of 76 m – Benzenberg found that the deviation to the east was 9.6 mm. Can you confirm that the value measured by Benzenberg almost agrees with the assumption that the earth turns once every 24 hours? (There is also a much smaller deviation towards the equator, not measured by Guglielmini, Benzenberg or anybody after them; it is mentioned here in order to complete the list of the effects of the rotation of the earth.) Both deviations are easily understood if one uses the fact that falling objects describe an ellipse around the centre of the rotating earth. This investigation shows that the path of a thrown stone does not lie on a plane for an observer standing on earth; in fact, for such an observer, the path cannot be drawn on a piece of paper!

Challenge 835

In 1835, the French engineer and mathematician Gustave-Gaspard Coriolis (1792–1843), the same who also introduced the modern concepts of 'work' and of 'kinetic energy', found a closely related effect that nobody had noticed in everyday life up to then. An object travelling in a rotating background does not move on a straight line. If the rotation is counter-clockwise, as is the case for the earth on the northern hemisphere, the velocity of objects is slightly turned to the right, while its magnitude stays constant. This so-called *Coriolis acceleration* (or Coriolis force) is due to the change of distance to the rotation axis. Can you deduce the analytical expression for it, namely $\mathbf{a}_C = 2\boldsymbol{\omega} \times \mathbf{v}$?

Challenge 852

The Coriolis acceleration determines the handedness of many large scale phenomena with a spiral shape, such as the directions of cyclones and anticyclones in meteorology, the general wind patterns on earth and the deflection of ocean currents and tides. Most beautifully, the Coriolis acceleration explains why icebergs do not follow the direction of the wind as they drift away from the polar caps. The Coriolis acceleration also plays a role in the flight of canon balls (that was the original interest of Coriolis), in satellite launches, in the motion of sunspots and even in the motion of electrons in molecules. All these phenomena are of opposite sign on the northern and southern hemisphere and thus prove the rotation of the earth.

Ref. 52

Ref. 51

Ref. 53

Only in 1962, after several earlier attempts by other researchers, Asher Shapiro was the first to verify that the Coriolis effect has a tiny influence on the direction of the vortex formed by the water flowing out of a bathtub. More than a normal bathtub he had to use a carefully-designed experimental set-up, because contrary to an often-heard assertion, no such effect can be seen in real bathtubs. He succeeded only by carefully eliminating all disturbances from the system; for example, he waited 24 hours after the filling of the reservoir (and never actually stepped in or out of it!) in order to avoid any left-over motion of water which would disturb the effect, and built a carefully designed, completely rotationally-symmetric opening mechanism. Others have repeated the experiment on the southern hemisphere, confirming the result. In other words, the handedness of usual bathtub vortices is *not* caused by the rotation of the earth, but results from the way the water starts to flow out. But let us go on with the story about earth's rotation.

Ref. 53



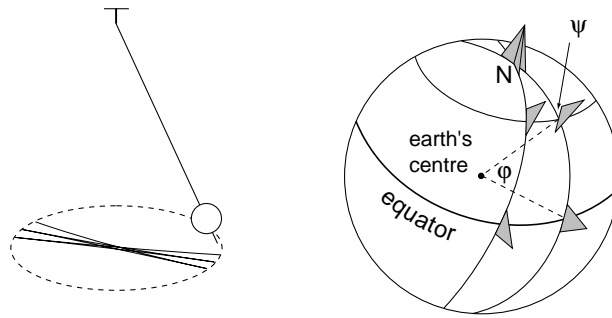

Figure 27 The motion of a pendulum on the rotating earth

Finally, in 1851, the French physician turned physicist Jean Bernard Léon Foucault (1819, Paris–1868, Paris) performed an experiment which cleared all doubts and which rendered him world-famous practically overnight. He suspended a 67 m long pendulum* in the Panthéon in Paris and showed the astonished public that the direction of its swing changed over time, rotating slowly. To everybody with a few minutes of patience to watch the change of direction, the experiment proved that the earth rotates. More precisely, the rotation period T_F of the oscillation plane seen on earth is given by

Challenge 886

$$T_F = \frac{24\text{h}}{\sin\varphi} \quad (25)$$

where φ is the latitude of the location of the pendulum, e.g. 0° at the equator and 90° at the north pole. This formula is perhaps the most beautiful result of Galilean kinematics.

Ref. 54

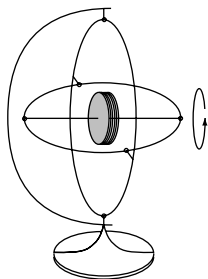

Figure 28 A gyroscope

Foucault is also the inventor and namer of the *gyroscope*. He built the device, shown in Figure 28, in 1852, one year after his pendulum. With it, he again demonstrated the rotation of the earth. Once it rotates, the axis stays fixed in space, but only when seen from far of the earth. For an observer on earth, the axis direction changes regularly with a period of 24 hours. Gyroscopes are now routinely used in ships and in aeroplanes to give the direction of north, because they are more precise and more reliable than magnetic compasses. In the most modern versions, one uses laser light running in circles instead of rotating masses.**

In 1909, Roland von Eötvös measured a simple effect: due to the rotation of the earth, the weight of a object depends on the direction in which it moves. As a result, a balance in rotation around the vertical axis does not stay perfectly horizontal: the balance starts to oscillate slightly. Can you explain the origin of the effect?

Challenge 920

In 1910, Eduard Hagen published the results of an even simpler experiment, proposed by Louis Poinsoot in 1851. If two masses on a horizontal bar are slowly moved towards the

- Challenge 869 * Why was such a long pendulum necessary? Understanding the reasons allows one to repeat the experiment at home, using a pendulum as short as 70 cm, with help of a few tricks.
 Ref. 55
 Challenge 903 ** Can you guess how rotation is detected in this case?



Challenge 937

support, as shown in Figure 29, and if the friction is kept low enough, the bar rotates. Obviously, this would not happen if the earth were not rotating. Can you explain the observation? This not-so-known effect is also useful for winning bets among physicists.

See page 500

In 1925, Albert Michelson* and his collaborators in Illinois constructed a vacuum interferometer with the incredible perimeter of 1.9 km. Interferometers produce bright and dark fringes of light; the position of the fringes depends on the way the interferometers rotates. The fringe shift is due to an effect first measured in 1913 by the French physicist Georges Sagnac: the rotation of a complete ring interferometer with angular frequency Ω produces a fringe shift with a phase $\Delta\phi$ given by

Challenge 954

$$\Delta\phi = \frac{8\pi\Omega A}{c\lambda} \quad (26)$$

where A is the area enclosed by the two interfering light rays, λ the wavelength, and c the speed of light. The effect is now called the *Sagnac effect* even though it had been predicted already 20 years earlier by Oliver Lodge.** Michelson and his team found a fringe shift with a period of 24 hours and of exactly the magnitude predicted by the rotation of the earth. Modern high precision versions use ring lasers with areas of only a few square metres, but are able to measure variations of the rotation rates of the earth of less than one part per million. Indeed, over the course of a year the length of a day varies irregularly by a few milliseconds, mostly due to influences from the sun or the moon, due to weather changes, and due to hot magma flows deep inside the earth. All these effects can be studied with such precision interferometers; they can also be used for research into the motion of the soil due to lunar tides, to earth quakes, and for checks of the theory of relativity.

Ref. 56

Ref. 57

In summary, observations show that the earth surface rotates at 463 m/s at the equator, a larger value than that of the speed of sound in air – about 340 m/s in usual conditions – and that we are in fact *whirling* through the universe.

Is the rotation of the earth *constant* over geological time scales? That is a really hard question. If you find any possible method to answer it, publish it! (The same is valid for the question whether the length of the year is constant.) Only few methods are known, as we will find out shortly.

Ref. 58

But why does the earth rotate at all? The rotation is a result of the rotating gas cloud from which the solar system formed. This connection explains that the sun and all planets, except one, turn around themselves in the same direction, and that they also all turn around the sun in that same direction. But the complete story is outside the scope of this text.

Ref. 61

Rotation is not the only motion of the earth; it performs other motions as well. This was known already long ago. In 128 BCE, the Greek astronomer Hipparchos discovered what

* Albert Abraham Michelson (1852, Strelno–1931, Pasadena) Prussian-Polish-US-American physicist, Nobel prize in physics in 1907, obsessed by the precise measurement of the speed of light.

** Oliver Lodge (1851–1940) was a British physicist who studied electromagnetic waves and tried to communicate with the dead. A strange but influential figure, his ideas are often cited when fun needs to be made of ‘physicists’; for example, he was one of those few physicists who believed that at the end of the 19th century physics was complete.

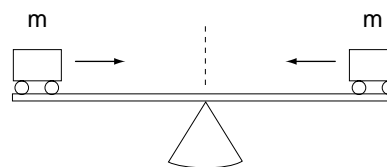

Figure 29 Showing the rotation of the earth through the rotation of an axis



is today called the (*equinoctial*) *precession*. He compared a measurement he made himself with another made 169 years before. Hipparchos found that the earth's changes direction over time. He concluded that the sky was moving; today we prefer to say that the axis of the earth is moving. During a period of 23 000 years the axis draws a cone with an opening angle of 23.5° . This motion is generated by the tidal forces of the moon and the sun on the equatorial bulge of the earth, which itself is due to its rotation.

In addition, the axis of the earth is not even fixed compared to the earth's surface. In 1884, by measuring the exact angle above the horizon of the celestial north pole, Friedrich Küstner (1856–1936) found that the axis of the earth *moves* with respect to the earth's crust, as Bessel had suggested forty years earlier. As a consequence of Küstner's discovery, the International Latitude Service was created. The *polar motion* Küstner discovered turned out to consist of three components: a small linear drift – not yet understood – a yearly elliptical motion due to seasonal changes of the air and water masses, and a circular motion* with a period of about 1.2 years due to fluctuations in the pressure at the bottom of the oceans. In practice, the north pole moves with an amplitude of 15 m around an average central position.

Ref. 59

In 1912, the German meteorologist and geophysicist Alfred Wegener (1880–1930) discovered an even larger effect. After studying the shapes of the continental shelves and the geological layers on both sides of the Atlantic, he conjectured that the continents *move*. Even though derided at first, his discoveries were genuine. Satellite measurements confirm this model; for example, the American continent moves away from the European continent by about 10 mm every year. There are also speculations that this velocity may have been much higher for certain periods in the past. The way to check this is to look at magnetization of sedimental rocks. At present, this is still a hot topic of research. Following the modern version of the model, called *plate tectonics*, the continents float on the fluid mantle of the earth like pieces of cork on water, and the convection inside the mantle provides the driving force for the motion.

Ref. 60

Does the earth move?

The centre of the earth is not at rest in the universe. In the third century BCE Aristarchos of Samos had already maintained that the earth turns around the sun. However, a fundamental difficulty of the heliocentric system is that the stars look the same all year long. How can this be, if the earth goes around the sun? The distance between the earth and the sun was known since the 17th century, but only in 1837, Friedrich Wilhelm Bessel** was the first to observe the *parallax* of a star. This was a result of extremely careful measurements and complex calculations: he discovered the *Bessel functions* in order to realize it. He was able to find a star, 61 Cygni, whose apparent position changed with the month of the year. Seen over the whole year, the star describes a small ellipse on the sky, with an opening of $0.588'$ (this is the modern value). After carefully eliminating all other possible explanations, he deduced that the change of position was due to the motion of the earth around the sun, and

* The circular motion, a wobble, was predicted by the great Swiss mathematician Leonhard Euler (1707–1783); using this prediction and Küstner's data, in 1891 Seth Carlo Chandler claimed to be the discoverer of the circular component.

** Friedrich Wilhelm Bessel (1784–1846), westphalian astronomer who left a successful business career to dedicate his life to the stars, and became the foremost astronomer of his time.



from the size of the ellipse he determined the distance to the star to be 105 Pm, or 11.1 light years.

Challenge 971

Bessel had thus managed for the first time to measure the distance of a star. By doing so he also proved that the earth is not fixed with respect to the stars in the sky and that the earth indeed revolves around the sun. The motion itself was not a surprise; it was predicted by universal gravity. In addition, the mentioned aberration of light, discovered in 1728 by James Bradley and to be discussed shortly, had already shown, albeit indirectly, that the earth moves around the sun.

See page 168

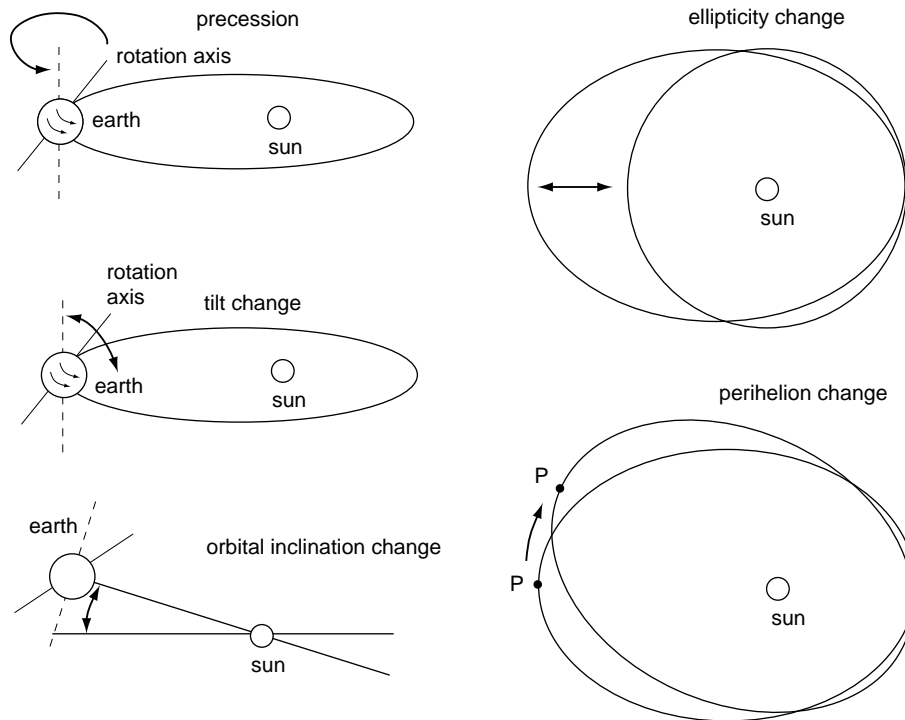

Figure 30 Changes in the earth's motion around the sun

With the improvement of telescopes, other motions of the earth were discovered. In 1748, James Bradley announced that there is a small regular *change* of the precession, which he called *nutation*, with a period of 18.6 years and an amplitude of 19.2 arc seconds. It is due to the fact that the plane of the moon's orbit around the earth is not exactly the same as the plane of the earth's orbit around the sun. Are you able to confirm that this situation can produce nutation?

Challenge 988

Astronomers also discovered that the 23.5 degree tilt – or *obliquity* – of the earth's axis, the angle between its intrinsic and its orbital angular momentum, actually changes from 22.1 to 24.5 degrees with a period of 41 000 years. This motion is due to the attraction of the sun and the deviations of the earth from a spherical shape. During the second world war, in 1941, the Serbian astronomer Milutin Milankovitch (1879–1958) retreated into solitude and studied the consequences. In his studies he realized that this 41 000 year period of the tilt,



together with the precession period of 23 000 years,* gives rise to the over twenty *ice ages* in the last two million years. This happens through stronger or weaker irradiation of the poles by the sun. The changing amounts of melted ice then lead to changes in average temperature. The last ice age had its peak about 20 000 years ago and finished around 10 000 years ago; the next is still far away. A spectacular confirmation of the ice age cycles, in addition to the many geological proofs, came through measurements of oxygen isotope ratios in sea sediments, which allow to track the average temperature in the past million years.

Ref. 62

The earth's orbit also changes its *eccentricity* with time, from completely circular to slightly oval and back. However, this happens in very complex ways, not with periodic regularity. The typical time scale is 100 000 to 125 000 years.

In addition, the earth's orbit changes in *inclination* with respect to the orbits of the other planets; this seems to happen regularly every 100 000 years. In this period the inclination changes from 2.5 degrees to minus 2.5 degrees and back.

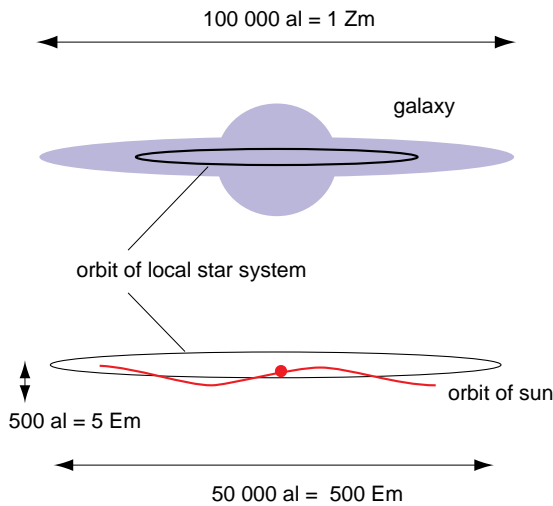

Figure 31 The motion of the sun around the galaxy

At our distance, the galaxy is 1 300 light years thick; we are 68 light years 'above' the centre plane. The sun, and with it the solar system, takes about 225 million years to turn once around the galactic centre, its orbital velocity being around 220 km/s. It seems that the sun will continue moving away from the galaxy plane until it is about 250 light years above the plane, and then move back. The oscillation period is estimated to be around 60 million years, and has been brought into relation with the mass extinctions of animal life on earth, possibly because some gas cloud is encountered on the way. The issue is still a hot topic of research.

Ref. 63

We turn around the galaxy centre because the formation of galaxies, like that of solar systems, always happens in a whirl. By the way, are you able to confirm by your own observation that our galaxy itself rotates?

Challenge 1005

* In fact, precession has two periods, one of 23 000 and one of 19 000 years due to the interaction between precession and perihelion shift.



Ref. 64 Finally, one can ask whether the galaxy moves. This can be measured because it is possible to give a value for the motion of the sun through the universe, defining it as the motion against the background radiation. This value has been measured to be 370 km/s. (The velocity of the *earth* through the background radiation of course depends on the season.) This value is a combination of the motion of the sun around the galaxy centre and of the motion of the galaxy itself. This latter motion is due to the gravitational attraction of the other, nearby galaxies in our local group of galaxies.*

See page 247 Why don't we feel all these motion of the earth? Again, this question was answered by the master. Galileo explained in his lectures and books that only *relative* velocities between bodies produce effects, not the absolute values of the velocities. For the senses, there is no difference between constant motion and rest. We do not feel the motion of the earth because we move with it, and because the accelerations it produces at everyday scale are tiny. Nevertheless, many of these motions do induce measurable effects in atomic clocks.

By the way, every physicist knows that the statement by Wittgenstein

Daß die Sonne morgen aufgehen wird, ist eine Hypothese; und das heißt: wir wissen nicht, ob sie aufgehen wird.**

Challenge 1022 is *wrong*. Can you explain why?

In summary, the earth really moves, and does so in rather complex ways. As Henri Poincaré would say, if we are on a given spot today, say the place of the Panthéon in Paris, and come back to the same spot tomorrow at the the same time, we are in fact 31 million kilometres away. This is one fact that would makes time travel extremely difficult in practice, even if it were possible in theory! But we stop this discussion at this point, and we have a look at motion in everyday life.

Curiosities and fun challenges of everyday motion

It is a mathematical fact that the casting of this pebble from my hand alters the centre of gravity of the universe.

Thomas Carlyle (1797–1881), *Sartor Resartus III.****

Here are a few facts to ponder.

Ref. 70 ■ A surprising effect is used in home tools such as hammer drills. Remember that when a small ball hits a large one at rest, both balls move after the hit, and the small one obviously moves faster than the large one.

Despite this result, when a short cylinder hits a long one of the same diameter and material, but with a length which is some *integer* multiple of that of the short one, something strange happens. After the hit, the small cylinder remains almost at rest, whereas the large one moves. Momentum conservation seems not to hold at all in this case. (In fact this is the reason that momentum conservation demonstrations in schools are always shown with spheres.) What is the reason of this effect?

Challenge 1056

* This is roughly the end of the ladder. Note that the expansion of the universe, to be studied later on, produces no motion.

** 'It is an hypothesis that the sun will rise tomorrow; and this means that we do not *know* whether it will rise.' This well-known statement is found in Ludwig Wittgenstein, *Tractatus*, 6.36311.

Challenge 1039

*** Do you agree with the quotation?



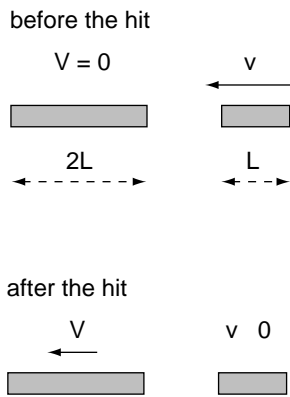

Figure 32 Momentum seems not to be conserved in this situation

▪ Does a wall get a stronger jolt when it is hit by a ball rebounding from it or when it is hit by a ball which remains stuck to it?

Challenge 1073

▪ Housewives know how to extract a cork from the inside of a wine bottle with a cloth. Can you imagine how?

Challenge 1090

▪ The sliding ladder problem, shown schematically in Figure 33, asks for the detailed motion of the ladder over time. The problem is more difficult than it looks, even if friction is not taken into account. Can you say whether the lower end always touches the floor?

Challenge 1107

▪ A common fly on the stern of a 30,000 ton ship of 100 m length tilts it by less than the diameter of an atom. Today, distances that small are easily measured. Can you think of at least two methods, one of which should not cost more than 2000 Euro?

Ref. 65

Challenge 3

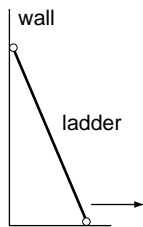

Figure 33 How does the ladder fall?

▪ The level of acceleration a human can survive depends on the duration one is subjected to it. For a tenth of a second, $30 g = 300 \text{ m/s}^2$, as generated by ejector seats in aeroplanes, is acceptable. (It seems that the record acceleration a human survived is about $80 g = 800 \text{ m/s}^2$.) But as a rule of thumb it is said that accelerations of $15 g = 150 \text{ m/s}^2$ or more are fatal.

▪ The highest *microscopic* accelerations are observed in particle collisions, where one gets values up to 10^{35} m/s^2 . The highest *macroscopic* accelerations are probably found in the collapsing interiors of *supernovae*, the exploding stars which can be so bright as to be visible in the sky even during the daytime. A candidate on earth is the interior of collapsing bubbles, in what is called *sonoluminescence*. This latter effect appears when air bubbles in water are expanded and contracted by underwater loudspeakers at around 30 kHz. At a certain threshold intensity, the bubble radius changes at 1500 m/s in as little as a few μm , giving an acceleration of several 10^{11} m/s^2 .

Ref. 66

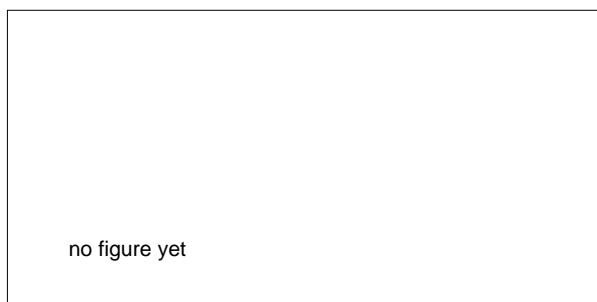

Figure 34 Observation of sonoluminescence with a diagram of the experimental set-up

▪ If a canon located at the equator shoots a bullet in the vertical direction, where does the bullet fall back?

Challenge 20

▪ Is travelling through interplanetary space healthy? People often fantasize about long trips through the cosmos. Experiments have shown that on trips of long duration, cosmic radiation, bone weakening, and muscle degeneration are the biggest dangers. Many medical experts question the viability of space travel lasting longer than a couple of years. Other dangers are rapid sunburn, at least near the sun, and exposure to the vacuum. So far only one man experienced vacuum without protection. He lost consciousness after 14 seconds, but survived unharmed.

Ref. 67

▪ How does the kinetic energy of a rifle bullet compare with that of a running man?

Challenge 37



- Challenge 54 ■ In which direction does a flame lean if it burns inside a jar on a rotating turntable?
 ■ A ping-pong ball is attached with a string to a stone, and the whole is put
 Challenge 71 under water in a jar. The jar is moved. In which direction does the ball move?
 ■ What happens to the size of an egg when one places it into a jar of vinegar
 Challenge 88 for a few days?
 ■ Does centrifugal acceleration exist? Most students at the university go
 through the shock of meeting a teacher saying that it doesn't because it is a
 'fictitious' quantity, in the face of what one experiences every day in the car
 when driving around a bend. Simply ask the teacher who denies it to define
 'existence'. (The definition physicists usually use is given in the intermezzo
 following this chapter.) Then check whether the definition applies to the term
 and make up your own mind.
 See page 456
 Challenge 105 ■ Rotation holds a surprise for everybody studying it carefully. Angular mo-
 mentum is a quantity with a magnitude and a direction. However, it is not a vector, as any
 mirror shows. The angular momentum of body circling in a plane parallel to a mirror be-
 haves differently from an arrow: its mirror image is not reflected! You can check this by
 yourself. For this reason, angular momentum is called a *pseudovector*. The fact has no im-
 Challenge 122 portant consequences in classical physics; but we have to keep it in mind for latter occasions.
 ■ What is the best way to transport full coffee or tea cups while at the same time avoiding
 Challenge 139 spilling any precious liquid?
 ■ The moon recedes from the earth by 3.8 cm a year, due to friction. Can you find the
 Challenge 156 responsible mechanism?
 ■ What is the amplitude of a pendulum oscillating in such a way
 that the absolute value of its acceleration at the lowest point and at
 Challenge 173 the return point are equal?
 ■ Is it correct that the value of the acceleration of a drop of water
 Challenge 190 falling through vapour is $g/7$?
 ■ Figure 36 shows the so-called *Celtic wiggle stone*, a stone that
 Ref. 70 starts rotating on a plane surface when it is put into oscillation. The
 size can vary between a few centimetres and a few metres. Simply
 by bending a spoon one can realize a primitive form of this strange
 device, if the bend is not completely symmetrical. The rotation is always in the same direc-
 tion. If the stone is put into rotation in the wrong direction, after a while it stops and starts
 rotating in the other sense! Can you explain the effect?
 Challenge 207
 Challenge 224 ■ What is the motion of the point below the sun on a map of the earth?
 ■ The moment of inertia of a body does depend on the shape of a body; usually, angular
 momentum and the angular velocity do not point in the same direction. Can you confirm
 Challenge 241 this?
 ■ Can it happen that a satellite dish for geostationary tv satellites focuses the sunshine
 Challenge 258 onto the receiver?
 ■ Why is it difficult to fire a rocket from an aeroplane in direction opposite to the motion
 Challenge 275 of the plane?
 ■ You have two hollow spheres: they have the same weight, the same size, and painted the
 same colour. One is made of copper, the other of aluminium. Obviously, they fall with the
 Challenge 292 same speed and acceleration. What happens if they both roll down a tilted plane?

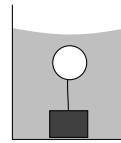

Figure 35
How does the ball move when the jar is moved?

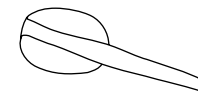

Figure 36 The famous Celtic stone



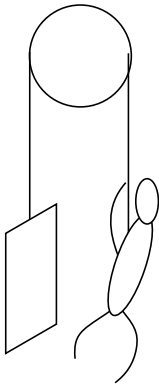

Figure 37 How does the ape move?

- An ape hangs on a rope. The rope hangs over a wheel and is attached to a mass of equal weight hanging down on the other side. What happens when the ape climbs the rope?
- What is the shape of a rope when rope jumping?
- How can you determine the speed of a rifle bullet only with a scale and a meter?

Challenge 309

Challenge 326

Challenge 343

Legs or wheels? – again

The acceleration and deceleration of standard wheel-driven cars is never much higher than about $1g = 9.8 \text{ m/s}^2$, the acceleration due to gravity on our planet. Higher accelerations are achieved by motor bikes and racing cars through the use of suspensions which divert weight to the axes and by the use of spoilers, so that the car is pushed downwards with more than its own weight. Modern spoilers are so efficient in pushing a car towards the track that racing cars could race on the roof of a tunnel without falling down.

Through the use of special tires these downwards forces are transformed into grip; modern racing tires allow forward, backward and sideways accelerations (necessary for speed increase, for braking and for turning corners) of about 1.1 to 1.3 times the load. Engineers once believed that a factor 1 was a theoretical limit and this limit is still sometimes found in textbooks; but advances in tire technology, mostly by making clever use of interlocking between the tire and the road surface as in a gear mechanism, have allowed engineers to achieve these higher values. The highest accelerations, around $4g$, are achieved when part of the tire melts and glues to the surface. Special tires designed to make this happen are used for dragsters, but high performance radio controlled model cars also achieve such values.

How do all these efforts compare to legs? High-jump athletes can achieve peak accelerations of about 2-4 times g , cheetahs over $3g$, bushbabies up to $13g$, locusts about $18g$, and fleas have been measured to accelerate about $135g$. The maximum acceleration known for animals is that of click beetles, a small insect able to accelerate at over $2000 \text{ m/s}^2 = 200g$, about the same as an airgun pellet when fired. Legs are thus definitively more efficient accelerating devices than wheels – a cheetah easily beats any car or motorbike – and evolution developed legs, instead of wheels, to improve the chances of an animal in danger to get to safety. In short, legs *outperform* wheels.

Ref. 71

There are other reasons to use legs instead of wheels. (Can you name some?) For example, legs, in contrast to wheels, allow walking on water. Most famous for this ability is the *basilisk*,* a lizard living in Central America. This reptile is about 50 cm long and has a mass of about 90 g. It looks like a miniature Tyrannosaurus Rex and can actually run over water surfaces on its hind legs. The motion has been studied in detail with high-speed cameras and by measurements using aluminium models of the animal's feet. The experiments show that the feet slapping on the water provides only 25% of the force necessary to run above water; the other 75% is provided by a pocket of compressed air that the basilisks create

Challenge 360

Ref. 72

* In the Middle Ages, the term 'basilisk' referred to a mythical monster supposed to appear shortly before the end of the world. Today, it is a small reptile in the Americas.



between their feet and the water. In fact, basilisks mainly walk on air. * It was calculated that a human is also able to walk on water, provided his feet hit the water with a speed of 100 km/h using the simultaneous physical power of 15 sprinters. Quite a feat for all those who ever did so.

Challenge 377

By the way, all animals have an even number of legs. Why? Do you know an exception? In fact, one can argue that no animal has less than four legs. Why?

After this short overview of motion based on contact, let us continue with the study of motion transmitted over distance, without any contact at all. It is easier and simpler to study.

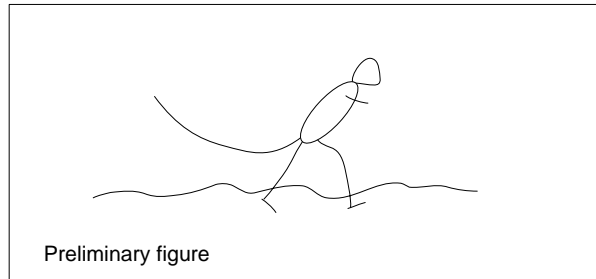

Figure 38 A basilisk lizard (*Basiliscus basiliscus*) running over water

The dynamics of gravitation

Caddi come corpo morto cade.

Dante, *Inferno*, c. V, v. 142. **

The first and main contact-free method to generate motion we discover in our environment is *height*. Waterfalls, snow, rain, and falling apples all rely on it. It was one of the fundamental discoveries of physics that height has this property because there is an interaction between every body and the earth. *Gravitation* produces an acceleration along the line connecting the centres of mass of the two bodies. Note that in order to make this statement, it is necessary to realize that the earth is a body in the same way as a stone or the moon, that this body is finite, and that therefore it has a centre and a mass. Today, these statements are common knowledge, but they are by no means evident from everyday personal experience. ***

How does gravitation change when two bodies are far apart? The experts for distant objects are the astronomers. Over the years they performed numerous measurements of the movements of the moon and the planets. The most industrious the Dane Tycho Brahe, **** who organized an industrial search for astronomical facts sponsored by his king. His measurements were the basis for the research of his young assistant, the Swabian astronomer Johannes Kepler ***** who found the first precise description of planetary motion. In 1684,

See page 456

Ref. 73 * Both effects used by basilisks are also found in fast canoeing.

** 'I fell like dead bodies fall.' Dante Alighieri (1265, Firenze–1321, Ravenna), the powerful Italian poet.

*** In several myths about the creation or the organization of the world, such as the biblical one, the earth is not an object, but an imprecisely defined entity, such as an island floating or surrounded by water with unclear boundaries or suspension method. Are you able to convince a friend that the earth is round and not flat? Can you find another argument apart from the fact that its shadow is round when it is visible on the moon? If the earth is round, the top of two buildings is further apart than their base. Can this effect be measured?

Challenge 394

Challenge 411

**** Tycho Brahe (1546–1601), famous Danish astronomer, builder of Uraniborg, the astronomical castle. He consumed almost 10% of the Danish gross national product for his research, which produced the first star catalogue and the first precise position measurements of planets.

***** Johannes Kepler (1571, Weil der Stadt–1630); after helping his mother defend herself in a trial where she was accused of witchcraft, he studies protestant theology, and became a teacher of mathematics, astronomy and rhetoric. His first book on astronomy made him famous, and he became assistant of Tycho Brahe and then,



all observations of planets and stones were condensed into an astonishingly simple result by the English physicist Robert Hooke: * every body of mass M attracts any other body towards its centre with an acceleration whose magnitude a is given by

$$a = G \frac{M}{r^2} \quad (27)$$

where r is the centre-to-centre distance of the two bodies. This is called the *universal 'law' of gravitation*, or universal gravity for short, for reasons to be explained shortly. If bodies are small compared to the distance r , or if they are spherical, the expression is correct as it stands. For non-spherical shapes the acceleration has to be calculated separately for each part of the bodies and then added together.

This inverse square property is often called Newton's 'law' of gravitation, because the English physicist Isaac Newton than Hooke that it agreed with all astronomical and terrestrial observations. Above all, however, he organized a better public relations campaign, in which he claimed to be the originator of the idea.

Ref. 74

Newton published a simple proof showing that this description of astronomical motion also gives the correct description for stones thrown through the air, down here on 'father earth'. To achieve this, he compared the acceleration a_m of the moon with that of stones g . For the ratio between these two accelerations, the inverse square relation predicts a value $a_m/g = R^2/d_m^2$, where R is the radius of the earth. The moon's distance d_m can be measured by triangulation, comparing the position of the moon against the starry background from two different points on earth. ** The result is $d_m/R = 60 \pm 3$, depending on the orbital position of the moon, so that an average ratio $a_m/g = 3.6 \cdot 10^3$ is predicted from universal gravity. But both accelerations can also be measured directly. On the surface of the earth, stones feel an acceleration due to gravitation with magnitude $g = 9.8 \text{ m/s}^2$, as determined by measuring the time stones need to fall a given distance. For the moon, the definition of acceleration, $a = dv/dt$, in the case of circular motion – roughly correct here – gives $a_m = d_m(2\pi/T)^2$, where $T = 2.4 \text{ Ms}$ is the time the moon takes for one orbit around the earth. *** The measurement of the radius of the earth **** yields $R = 6.4 \text{ Mm}$, so that the average moon-earth distance

at his teacher's death, the Imperial Mathematician. He was the first to use mathematics in the description of astronomical observations, and introduced the concept and field of 'celestial physics'.

* Robert Hooke, (1635–1703), important English physicist, secretary of the Royal Society.

** The first precise – but not the first – measurement was realized in 1752 by the French astronomers Lalande and La Caille, who simultaneously measured the position of the moon seen from Berlin and from Le Cap.

Challenge 428

*** This is deduced easily by noting that for an object in circular motion, the magnitude v of the velocity $\mathbf{v} = d\mathbf{x}/dt$ is given as $v = 2\pi r/T$. The drawing of the vector \mathbf{v} over time, the so-called *hodograph*, shows that it behaves exactly like the position of the object. Therefore the magnitude a of the acceleration $\mathbf{a} = d\mathbf{v}/dt$ is given by the corresponding expression, namely $a = 2\pi v/T$.

Ref. 75

**** This is the hardest quantity to measure oneself. The most surprising way to determine the earth's size is the following: watch a sunset in the garden of a house, with a stopwatch in hand. When the last ray of the sun disappears, start the stopwatch and run upstairs. There, the sun is still visible; stop the stopwatch when the sun disappears again and note the time t . Measure the height distance h of the two eye positions where the sun was observed. The earth's radius R is then given by $R = kh/t^2$, with $k = 378 \text{ s}^2$.

Challenge 445

Ref. 76

There is also a simple way to measure the distance to the moon, once the size of the earth is known. Take a photograph of the moon when it is high in the sky, and call θ its zenith angle, i.e. its angle from the vertical. Make another photograph of the moon a few hours later, when it is just above the horizon. On this picture, contrary to a common optical illusion, the moon is smaller, because it is further away. With a drawing the

See page 50



is $d_m = 0.38 Gm$. One thus has $a_m/g = 3.6 \cdot 10^3$, in agreement with the above prediction. With this famous ‘moon calculation’ we have thus shown that the inverse square property of gravitation indeed describes both the motion of the moon and that of stones. You might want to deduce the value of GM .

Challenge 479

From the observation that on the earth all motion eventually comes to rest, whereas in the sky all motion is eternal, Aristotle and many others had concluded that motion in the sublunar world has different properties than motion in the translunar world. Several thinkers had criticized this distinction, notably the French philosopher and rector of the University of Paris, Jean Buridan. * The moon calculation was the most important result showing this distinction to be wrong. This is the reason for calling the expression (27) the *universal* ‘law’ of gravitation.

Ref. 77

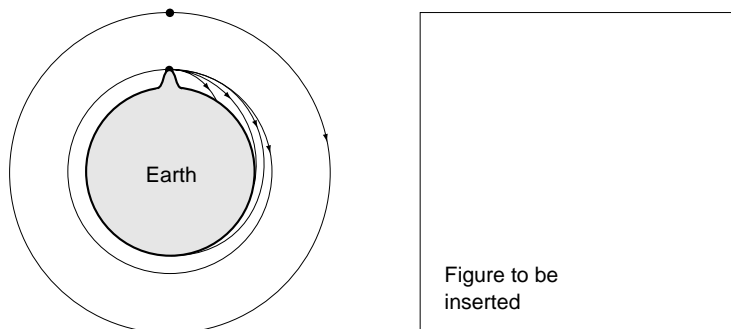

Figure 39 A physicist’s and an artist’s view of the fall of the moon: a graph by Christiaan Huygens and a marble by Auguste Rodin

This result allows us to answer another old question. Why does the moon not fall from the sky? Well, the preceding discussion showed that *fall* is motion due to gravitation. Therefore the moon actually *is* falling, with the peculiarity that instead of falling *towards* the earth, it is continuously falling *around* it. The moon is continuously missing the earth. **

Properties of gravitation

Gravitation implies that the path of a stone is not a parabola, as stated earlier, but actually an ellipse around the centre of the earth. This happens for exactly the same reason that the planets move in ellipses around the sun. Are you able to confirm this statement?

Challenge 513

reason for this becomes clear immediately. If q is the ratio of the two moon diameters, the earth-moon distance d_m is given by the relation $d_m^2 = R^2 + [2Rq \cos \theta / (1 - q^2)]^2$. Enjoy its derivation from the drawing.

Challenge 462

Another possibility is to determine the size of the moon by comparing it to the size of the shadow of the earth during an eclipse. The distance to the moon is then computed from its angular size, about 0.5° .

* Jean Buridan (ca. 1295–ca. 1366) was also one of the first modern thinkers to speculate on a rotation of the earth about an axis.

** Another way to put it is to use the answer of the Dutch physicist Christiaan Huygens (1629–1695): the moon does not fall from the sky because of the centrifugal acceleration. As explained on page 81, this explanation is nowadays out of favour at most universities.

Ref. 78

Challenge 496

There is a beautiful problem connected to the left part of the figure: Which points of the surface of the earth can be reached by shooting from a mountain? And which points can be reached by shooting only horizontally?



Universal gravitation allows us to solve a mystery. The puzzling acceleration value $g = 9.8 \text{ m/s}^2$ we encountered in equation (3) is thus due to the relation

$$g = GM_{\text{earth}}/R_{\text{earth}}^2 \quad . \quad (28)$$

It can be deduced from equation (27) by taking the earth to be spherical. Obviously, the value for g is almost constant on the surface of the earth because the earth is almost a sphere. The expression also explains why g is smaller if one rises in the air, and the deviations of the shape of the earth from sphericity explain why g is different at the poles and larger on a plateau.

By the way, it is possible to devise a simple machine, other than a yo-yo, which slows down the acceleration of gravity by a known amount, so that one can measure its value more easily. Can you imagine it?

Challenge 530

Note that 9.8 is roughly π^2 . This is *not* a coincidence: the metre has been chosen in such a way to make this correct. The period of a swinging pendulum, i.e. a back and forward swing, is given by*

Challenge 547

$$T = 2\pi\sqrt{\frac{l}{g}} \quad . \quad (29)$$

If the meter had been defined such that $T/2 = 1 \text{ s}$, the value of the normal acceleration g would have been exactly $\pi^2 \text{ m/s}^2$. This first proposal in 1790 by Talleyrand was rejected by the conference which defined the metre because variations in the value of g with geographical position and in the length of a pendulum with varying temperature induce errors which are too large to give a useful definition.

Then the proposal was made to define the metre as $1/40,000,000$ of the circumference of the earth through the poles, a so-called *meridian*. This proposal was almost identical to – but much more precise than – the pendulum proposal. The meridian definition of the metre was then adopted by the French national assembly on the 26th of March 1791, with the statement that ‘a meridian passes under the feet of every human being, and all meridians are equal.’

But one can still ask: Why does the earth have the mass and size it has? And why does G have the value it has? The first question asks for a history of the solar system; it is still unanswered and a topic of research. The second question is addressed in Appendix B.

If all objects attract each other, that should also be the case for objects in everyday life. Gravity must also work *sideways*. This is indeed the case, even though the effects are so small that they were measured only long after universal gravity had predicted them. Measuring this effect allows to determine the gravitational constant G .

Note that measuring G is also the only way to determine the mass of the *earth*. The first to do so, in 1798, was the English physicist Henry Cavendish (1731–1810); therefore he called the result of his experiments ‘weighing the earth’. Are you able to imagine how he did it? The value found in experiments is

Challenge 581

* Formula (29) is noteworthy because the period does *not* depend on the amplitude. (This is true as long as the oscillation angle is smaller than about 30 degrees.) Galileo discovered this as a student, when observing a chandelier hanging on a long rope in the dome of Pisa. Using his heartbeat as a clock he found that even though the amplitude of the swing got smaller and smaller, the time for the swing stayed the same.

Challenge 564

A leg also moves like a pendulum, when one walks normally. Why then do taller people tend to walk faster?



$$G = 6.7 \cdot 10^{-11} \text{ Nm}^2/\text{kg}^2 \quad . \quad (30)$$

Cavendish’s experiments were thus the first to confirm that gravity works also sideways.

Challenge 598

For example, two average people at the close distance of 0.1 m feel an acceleration towards each other which is smaller than that exerted by the leg of a common fly on the skin. Therefore we usually do not notice the attraction to other people. When we notice it, it is much stronger than that. This simple calculation thus proves that gravitation cannot be at the origin of people falling in love, and that sexual attraction is not of gravitational, but of different origin. This other interaction will be studied later in our walk; it is called *electromagnetism*.

But gravity has more interesting properties to offer. The effects of gravitation can also be described by another observable, namely the (*gravitational*) potential ϕ . We then have the simple relation that the acceleration is given by the *gradient* of the potential

$$\mathbf{a} = -\nabla\phi \quad \text{or} \quad \mathbf{a} = -\text{grad } \phi \quad . \quad (31)$$

The gradient is just a learned term for ‘slope along the steepest direction’. It is defined for any point on a slope, is long for a steep one and short for a flat one, and it points in the direction of steepest ascent, as shown in Figure 40. The gradient is abbreviated ∇ , pronounced ‘nabla’, and is mathematically defined as the vector $\nabla\phi = (\partial\phi/\partial x, \partial\phi/\partial y, \partial\phi/\partial z) = \text{grad } \phi$. The minus sign in the above definitions is introduced by convention, in order to have higher potential values at larger heights. * For a point-like or a spherical body of mass M , the potential is

$$\phi = -G \frac{M}{r} \quad . \quad (32)$$

A potential considerably simplifies the description of motion, since a potential is additive: given the potential of a point particle, one can calculate the potential and then the motion around any other, irregularly shaped object. ** The potential ϕ is an interesting quantity

* In two or more dimensions slopes are written $\partial\phi/\partial z$ – where ∂ is still pronounced ‘d’ – because in those cases the expression $d\phi/dz$ has a slightly different meaning. The details lie outside the scope of this walk.

** Alternatively, for a general, extended body, the potential is found by requiring that the *divergence* of its gradient is given by the mass (or charge) density times some proportionality constant. More precisely, one has

$$\Delta\phi = 4\pi G\rho \quad (33)$$

where $\rho = \rho(\mathbf{x}, t)$ is the mass volume density of the body and the operator Δ , pronounced ‘delta’, is defined as $\Delta f = \nabla\nabla f = \partial^2 f/\partial x^2 + \partial^2 f/\partial y^2 + \partial^2 f/\partial z^2$. Equation (33) is called the *Poisson equation* for the potential ϕ , after Siméon-Denis Poisson (1781–1840), eminent French mathematician and physicist. The positions at which ρ is not zero are called the *sources* of the potential. The source term $\Delta\phi$ of a function is a measure for how much the function $\phi(x)$ at a point x differs from the average value in a region around that point. (Can you show this, by showing that $\Delta\phi \approx \bar{\phi} - \phi(x)$?) In other words, the Poisson equation (33) implies that the actual value of the potential at a point is the same as the average value around that point minus the mass density multiplied by $4\pi G$. In particular, in the case of empty space the potential at a point is equal to the average of the potential around that point.

Challenge 615

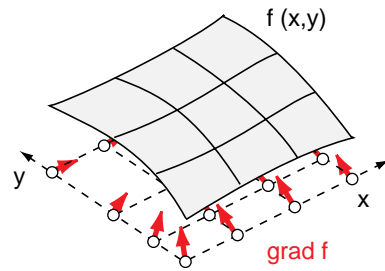

Figure 40 The potential and the gradient



because with a single number at every position in space we can describe the vector aspects of gravitational acceleration. It automatically describes that gravity in New Zealand acts in the opposite direction to gravity in Paris. In addition, the potential suggests the introduction of the so-called *potential energy*

$$U = m\phi \quad (34)$$

which allows us to determine the change of *kinetic energy* T of a body falling from a point 1 to a point 2 via

$$T_1 - T_2 = U_2 - U_1 \quad \text{or} \quad \frac{1}{2}m_1\mathbf{v}_1^2 - \frac{1}{2}m_2\mathbf{v}_2^2 = m\phi_2 - m\phi_1 \quad . \quad (35)$$

In other words, the *total energy*, defined as the sum of kinetic and potential energy, is *conserved* in motion due to gravity. This is a characteristic property of gravitation. Not all accelerations can be derived from a potential; systems with this property are called *conservative*. The accelerations due to friction are not conservative, but those due to electromagnetism are.

Interestingly, the number of dimensions of space d is coded into the potential of a spherical mass: its dependence on the radius r is in fact $1/r^{d-2}$. The exponent $d - 2$ has been checked experimentally to high precision; no deviation of d from 3 has ever been found.

Challenge 632

Ref. 80

The concept of potential helps in understanding *shape* of the earth. Since most of the earth is still liquid when seen on a large scale, its surface is always horizontal with respect to the direction determined by the combination of the accelerations of gravity and rotation. In short, the earth is *not* a sphere. The mathematical shape following from this requirement is called a *geoid*. That shape is given approximately, with an error of less than about 50 m, by an ellipsoid. Can you describe the geoid mathematically? The geoid is an excellent approximation to the actual shape of the earth; sea level differs from it by less than twenty metres. The differences can be measured with satellite radar and are of great interest to geologists and geographers. For example, it turns out that the south pole is nearer to the equatorial plane than the north pole by about 30 m. This is probably due to the large land masses in the northern hemisphere.

Ref. 81

Ref. 82

Challenge 649

The inertia of matter, through the so-called ‘centrifugal force’, increases the radius of the earth at the equator; in other words, the earth is *flattened* at the poles. The equator has a radius a of 6.38 Mm, whereas the distance b from the poles to the centre of the earth is 6.36 Mm. The precise flattening $(a - b)/a$ has the value $1/298.3 = 0.0034$. As a result, the top of Mount Chimborazo in Ecuador, even though its height is only 6267 m above sea level, is about 20 km farther away from the centre of the earth than the top of Mount Qomolangma* in Nepal, whose height above sea level is 8850 m.

See Appendix B

As a consequence, if the earth stopped rotating, the water of the oceans would flow north; all of Europe would be under water, except for the few mountains of the Alps higher than about 4 km. The northern parts of Europe would be covered by between 6 km and 10 km of water. Mount Qomolangma would be over 11 km above sea level. The resulting shape

Often the concept of *gravitational field* is introduced, defined as $\mathbf{g} = -\nabla\phi$. We avoid this in our walk, because we will discover that following the theory of relativity gravity is not due to a field at all; in fact even the concept of gravitational potential turns out to be only an approximation.

* Mount Qomolangma is sometimes also called Mount Everest.



change of the earth would also produce extremely strong earthquakes and storms. As long as these effects are lacking, we are *sure* that the sun will indeed rise tomorrow, despite what some philosophers might pretend.

See page 79

Gravitation in the sky

The expression $a = GM/r^2$ also describes the motion of all the planets around the sun. Anyone can check that the planets always stay within the *zodiac*, a narrow stripe across the sky. The centre line of the zodiac gives the path of the sun and is called the *ecliptic*, since the moon must be located on it to produce an eclipse. But the detailed motion of the planets is not easy to describe.* A few generations before Hooke, the Swabian astronomer Johannes Kepler had deduced several ‘laws’ in his painstaking research about the movements of the planets in the zodiac. The three main ones are:

- Planets move on ellipses with the sun located at one focus (1609);
- Planets sweep out equal areas in equal times (1609);
- For all planets, calling the duration of the orbit T and semimajor axis d , the ratio T^2/d^3 is the same (1619).

The sheer work required to deduce them was enormous. Kepler had no calculation machine available, not even a slide rule. The calculation technology he used was the recently discovered logarithms. Anyone who has used tables of logarithms to actually perform calculations can get a feeling for the large amount of work behind these three discoveries.

Can you show that all three laws follow from the expression of universal gravity?

Challenge 666

Even Newton was not able to write down, let even to handle, differential equations at the time he published his results on gravitation. In fact his notation and calculation methods were poor. The English mathematician G.H. Hardy** used to say that insistence to use Newton’s integral and differential notation, which he developed much later – instead of using the one of his rival Leibniz, common today – threw back English mathematics by 100 years.

Ref. 16

Kepler, Hooke and Newton became famous because they brought order to the description of planetary motion. This achievement, though of small practical significance, was widely publicized because of the age-old prejudices linked to astrology.

However, there is more to gravitation. Universal gravity explains the motion and shape of the milky way and of the other galaxies, the motion of many weather phenomena, and explains why the earth has an atmosphere but the moon does not. (Can you?) In fact, universal gravity explains much more about the moon.

Challenge 683

* The apparent height of the ecliptic changes with the time of the year and is the reason for the changing seasons. Therefore seasons are a gravitational effect as well.

** G.H. Hardy (1877–1947) English number theorist. He ‘discovered’ the famous indian mathematician Srinivasa Ramanujan, bringing him to Britain, and wrote the well-known *Apology of a mathematician*.

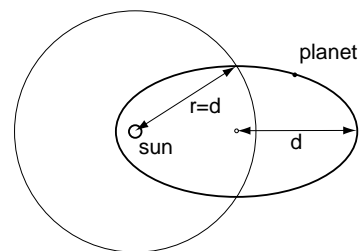

Figure 41 The motion of a planet around the sun, showing its semi-major axis d , which is also the spatial average of its distance from the sun



The moon

One often hears that the moon always shows the same side to the earth. But this is wrong. As one can check with the naked eye, a given feature in the centre of the face of the moon at full moon is not at the centre one week later. The various motions leading to this change are called *librations*; they appear mainly because the moon does not describe a circular, but an elliptical orbit around the earth and because the axis of the moon is slightly inclined compared to that of its rotation around the earth. As a result, only around 45% of the moon's surface are permanently hidden from earth.

The first photographs of the hidden areas were taken in the 1960s by a Soviet satellite. The surface is much irregular than the visible one, as it is the hidden side which mainly intercepts all asteroids attracted by the earth. Thus the gravitation of the moon helps to deflect asteroids from the earth. The number of animal life extinctions is thus brought to a small, but not negligible number. In other words, the gravitational attraction of the moon saved the life of humans already many times over.*

The trips to the moon in the 1970s also showed that the moon originated from the earth itself: long ago, an object hit the earth almost tangentially and threw much material up into the sky. This is the only mechanism able to explain the large size of the moon, its low iron content, as well as its general material composition.

Ref. 83

The moon is receding from the earth at 3.8 cm a year. This result confirms the old deduction that the tides slow down the earth's rotation. Can you imagine how this measurement was performed? ** Since the moon slows down the earth, the earth also changes shape due to this effect. (Remember that the shape of the earth depends on its rotation speed.) These changes in shape influence the tectonic activity of the earth, and maybe also the drift of the continents.

Challenge 700

The moon has many effects on animal life. A famous example is the midge *Clunio*, which lives on sea coasts with pronounced tides. *Clunio* lives between 6 and 12 weeks as a larva then hatches and lives only one or two hours as adult flying insect, during which it reproduces. The reproduction is only successful if the midge hatches during the low tide phase of a spring tide. Spring tides are the especially strong tides during the full and new moons, when the solar and lunar effects add, and occur only every 14.8 days. In 1995, Dietrich Neumann showed that the larvae have two built-in clocks, a circadian and a circalunar one, which together control the hatching to precisely those few hours when the insect can reproduce. He also showed that the circalunar clock is synchronized by the brightness of the moon at night. In other words, the larvae watch the moon at night and then decide when to hatch: they are the smallest known astronomers.

Ref. 84

If insects can have circalunar cycles, it should come as a surprise that women also have such a cycle. However, the origin of the cycle length is still unknown.

Ref. 85

The moon also helps to stabilize the tilt of the earth's axis, keeping it more or less fixed relative to the plane of motion around the sun. Without the moon, the axis would change

* The web pages cfa-www.harvard.edu/iau/lists/Closest.html and cfa-www.harvard.edu/iau/lists/InnerPlot.html give an impression of the number of objects which almost hit the earth every year. Without the moon, we would have many additional catastrophes.

** If you want to read about the motion of the moon in all its fascinating details, have a look at MARTIN C. GUTZWILLER, *Moon-earth-sun: the oldest three body problem*, *Reviews of Modern Physics* **70**, pp. 589–639, 1998.



its direction irregularly, we would not have a regular day and night rhythm, we would have extremely large climate changes, and the evolution of life would have been impossible. Without the moon, the earth would also rotate much faster and we would have much more unfriendly weather. The moon's main remaining effect on the earth, the precession of its axis, is responsible for the ice ages.

We will also see that the moon shields the earth from cosmic radiation by greatly increasing the earth's magnetic field. In other words, the moon is of central importance for the evolution of life. Understanding how often planets have moon-sized moons is thus important for the estimation of the probability that life exists on other planets. So far, it seems that large moons are rare; the issue is still an area of research. But let us return to the effects of gravitation in the sky.

Orbits

The path of a body orbiting another under the influence of gravity is an ellipse with the central body at one focus. A circular orbit is also possible, a circle being a special case of an ellipse.

Gravitation implies that comets return. The English astronomer Edmund Halley (1656–1742) was the first to take this conclusion and to predict the return of a comet. It arrived at the predicted date in 1756, and is now named after him. The period of Halley's comet is between 74 and 80 years; the first recorded sighting was 22 centuries ago, and it has been seen at every one of its thirty passages since, the last time in 1986.

Depending on the initial energy and the initial angular momentum of the body with respect to the central planet, there are two additional possibilities: *parabolic* paths and *hyperbolic* paths. Can you determine the conditions on the energy and the angular momentum for these paths to appear?

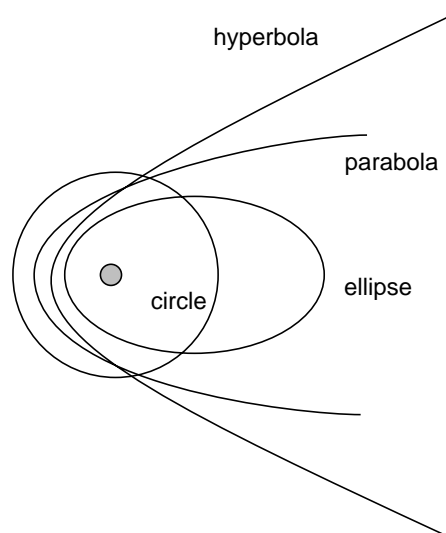

Figure 42 The possible orbits due to universal gravity



Some comets follow parabolas when moving around the sun, but most follow elliptical paths. Hyperbolic paths are less common; they are often used to change the direction of artificial satellites on their way through the solar system.

For more than two gravitating objects, many more possibilities for motions of bodies appear. In fact, the many-body problem is still a topic of research, and the results are fascinating mathematically, even though a bit less physically. Thus we cover only a few examples here.

When several planets circle a sun, they also attract each other. Planets thus do not move in perfect ellipses. The largest deviation is a perihelion change. It is observed for Mercury and a few other planets, including the earth. Other deviations from elliptical paths appear during a single orbit. In 1846, the observed deviations of the motion of the planet Uranus from the path predicted by universal gravity were used to predict the existence of another planet, Neptune, which was discovered shortly afterwards.

See Figure 30

We have seen that mass is always positive and that gravitation is thus always attractive; there is no *antigravity*. Can gravity be used for *levitation* nevertheless, maybe using more than two bodies? Yes; there are two examples. * The first, the geostationary satellites, is used for easy transmission of television and other signals from and towards earth.

See page 63

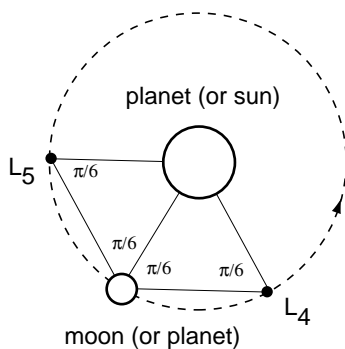

Figure 43 The two stable Lagrangian points

The *Lagrangian libration points* are the second example. Named after their discoverer, these are points in space near a two-body system, such as moon-earth or earth-sun, in which small objects have a stable equilibrium position. Can you locate them, not forgetting to take rotation into account? There are three additional Lagrangian points on the earth-moon axis. How many are of them stable?

Challenge 717

Challenge 734

There are thousands of asteroids, called *Trojan asteroids*, at and around the Lagrangian points of the Sun-Jupiter system. In 1990, a Trojan asteroid for the Mars-Sun system was discovered. Finally, in 1997, a Trojan asteroid was found which follows the earth in its way around the sun. This second companion of the earths has a diameter of 5 km. Similarly, on the main Lagrangian points of the earth-moon system a high concentration of dust has been observed.

Ref. 89

To sum up, the single equation $\mathbf{a} = -GM\mathbf{r}/r^3$ correctly describes a large number of phenomena in the sky. The first person to make clear that the expression describes *everything* happening in the sky was Pierre Simon Laplace** famous treatise *Mécanique céleste* He summarized the book in the famous answer he gave to Napoleon, when the latter told him ‘I do not read anything about the creator in your book’; Laplace answered: ‘I did not need this hypothesis any more’.

These results are quite a feat for such a simple expression. How precise is it? Since astronomy allows the most precise measurements of gravitational motion, it also provides

* Levitation is discussed in detail on page 389.

** Pierre Simon Laplace (1749, Beaumont-en-Auge-1827, Paris), important French mathematician. His treatise appeared in 5 volumes between 1798 and 1825.



the most stringent tests. Simon Newcomb (1835–1909) repeated Laplace’s analysis and concluded after intensive study that there was only one known example of discrepancy from universal gravity, namely one observation for the planet Mercury. (Nowadays a few more are known.) The point most distant from the sun of the orbit of planet Mercury, its perihelion, changes with a rate slightly smaller than the predicted one: the tiny difference is around 43 arc seconds per century. The study of motion had to wait for Albert Einstein to explain it.

Ref. 90

Tides

Why do physics texts always talk about tides? Because, as general relativity shows, tides prove that space is curved! It is thus useful to study them a bit in more detail. Gravitation describes the sea tides as results of the attraction of the ocean water by the moon and the sun. Tides are interesting; even though the amplitude of the tides is only about 0.5 m on the open sea, it can be up to 20 m at special places near the coast. Can you imagine why? The *soil* is also lifted and lowered by the sun and the moon, by about 0.3 m, as satellite measurements show. Even the *atmosphere* is subject to tides, and the corresponding pressure variations can be filtered out from the weather pressure measurements.

Challenge 751

Ref. 29

Ref. 91

Tides appear for any *extended* body moving in the gravitational field of another. To understand the origin of tides, it suffices to picture a body in orbit, like the earth, and to imagine its components, such as the segments of Figure 44, as being kept together by springs. Universal gravity implies that orbits are slower the more distant they are from a central body. As a result, the segment on the outside of the orbit would like to be slower than the central one; through the springs it is *pulled* by the rest of the body. In contrast, the inside segment would like to orbit more rapidly and is thus *retained* by the others. Being slowed down, the inside segments wants to fall towards the sun. In sum, both segments feel a pull away from the centre of the body, until the springs stop the deformation. Therefore, *extended bodies are deformed in direction of the field inhomogeneity*.

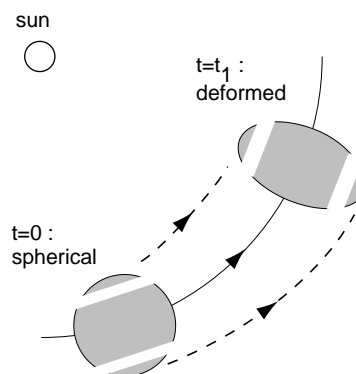

Figure 44 Tidal deformations due to gravity

For example, as a result of tidal forces, the moon always points with (almost) the same face to the earth; in addition, its radius towards the earth is larger by about 30 km than the radius perpendicular to it. If the inner springs are too weak, the body is torn into pieces; in this way a *ring* of fragments can form, such as the asteroid ring between Mars and Jupiter or the rings around Saturn.

Let us return to the earth though. If a body is surrounded by water, it will form bulges in direction of the applied gravitational field. In order to measure and compare the strength of the tides from the sun and the moon, we reduce tidal effects to their bare minimum, as shown in Figure 45. Tides appear because nearby points falling together approach or diverge, depending on their relative position. Tides thus depend on the change of acceleration



with distance; in other words, this *relative* acceleration is the derivative of gravitational acceleration.

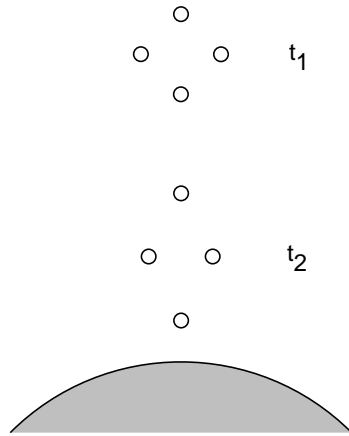

Figure 45 The origin of tides

Using the numbers from Appendix B, the gravitational accelerations from the sun and the moon are

$$a_{\text{sun}} = \frac{GM_{\text{sun}}}{d_{\text{sun}}^2} = 5.9 \text{ mm/s}^2$$

$$a_{\text{moon}} = \frac{GM_{\text{moon}}}{d_{\text{moon}}^2} = 0.033 \text{ mm/s}^2 \quad (36)$$

and thus the attraction from the moon is about 178 times weaker than that from the sun.

The *relative* acceleration $b = \nabla a$ of any two nearby point masses falling together near a large spherical mass M is given by

$$b = -\frac{2GM}{r^3} \quad (37)$$

which yields the values

$$b_{\text{sun}} = -\frac{2GM_{\text{sun}}}{d_{\text{sun}}^3} = -0.8 \cdot 10^{-13} / \text{s}^2$$

$$b_{\text{moon}} = -\frac{2GM_{\text{moon}}}{d_{\text{moon}}^3} = -1.7 \cdot 10^{-13} \quad (38)$$

In other words, despite the much weaker pull of the moon, its tides are predicted to be over *twice as strong* as the tides from the sun, as indeed is observed. When sun, moon and earth are aligned, the two tides add up; these so-called *spring tides* are especially strong and happen every 14.8 days, at full and new moon.

Tides also produce *friction*. The friction leads to a slowdown of earth's rotation. Nowadays, the slowdown can be measured by precise clocks (even though short time variations due to other effects, such as the weather, are often larger). The results fit well with fossil results showing that 400 million years ago, in the Devon, a year had 400 days, and a day about 22 hours. It is also estimated that 900 million years ago, each of the 481 days of a year were 18.2 hours long. The friction at the basis of this slowdown also results in an increase of the distance of the moon by about 3.8 cm per year. Are you able to explain why?

In summary, tides are due to relative accelerations of nearby mass points. This has an important consequence. In the chapter on general relativity we will find that time multiplied by the speed of light plays the same role as length. Time then becomes an additional dimension, as shown in Figure 46. Using this similarity, two free particles moving in the same direction correspond to parallel lines in space-time. Two particles falling side-by-side also correspond to parallel lines. Tides show that such two particles approach each other. In other words, tides imply that parallel lines approach each other. But parallel lines can approach each other *only* if space-time is curved. In short, tides imply *curved* space-time and space. This simple reasoning could have already been performed in the 18th century; however, it took another 200 years and Albert Einstein's genius to uncover it.

Challenge 768

Ref. 57

Challenge 785

See page 233

See page 266



Can light fall?

See page 168

Towards the end of the 17th century people found out that light has a finite velocity – a story which we will tell in detail later on. An entity which moves with infinite velocity cannot be affected by gravity, as there is no time to produce an effect. An entity with a finite speed, however, should feel gravity and thus fall.

Ref. 92

Does the speed increase when light reaches the surface of the earth? For almost three centuries people had no measurement means to detect any effect; so the question was not investigated. Then, in 1801, the Prussian astronomer Johann Soldner was the first to put the question in a different way. Being an astronomer, he was used to measuring stars and their observation angles. He realized that due to gravity, light passing near a massive body would be *deflected*.

Challenge 802

For a body on a hyperbolic path, moving with velocity c past a body of mass M at distance b , Soldner deduced the deflection angle

$$\alpha_{\text{univ.grav.}} = \frac{2 GM}{b c^2} . \tag{39}$$

See page 259

In his time, this angle was far too small to be measured even for light deflected by the mass of the sun, where it turns out to be at most a tiny $0.88'' = 4.3 \mu\text{rad}$. Thus the issue was forgotten. Had it been pursued, general relativity would have started as an experimental science, and not as a theoretical effort by Albert Einstein! Why? The value so calculated is *different* from the measured value. The first measurement took place in 1919 and found a deflection up to $1.75''$, exactly the double of expression (39). The reason is not easy to find; it is due to the curvature of space, as we will see.* In summary, light can fall, but the issue bears some surprises.

What is mass? – again

Mass describes how an object interacts with others. In our walk, we have encountered two of its aspects. *Inertial mass* is the property which keeps objects moving and which offers resistance to change of their motion. *Gravitational mass* is the property responsible for the acceleration of bodies nearby (the active aspect) or of being accelerated by objects nearby (the passive aspect). For example, the active aspect of the mass of the earth determines the surface acceleration of bodies; the passive aspect of the bodies allows us to weigh them in order to measure their mass using distances only, e.g. on a scale or a balance. The gravitational mass is the basis of *weight*, the difficulty to lift things.*

Is the gravitational mass of a body equal to the inertial mass? A rough answer is given by the experience that an object which is difficult to move is also difficult to lift. The simplest experiment is to take two bodies of different mass and let them fall. If the acceleration is

Challenge 819

* By the way, how would you measure the deflection of light near the bright sun?

Challenge 836

* What are the values shown by a balance for a person of 85 kg juggling three balls of 0.3 kg each?

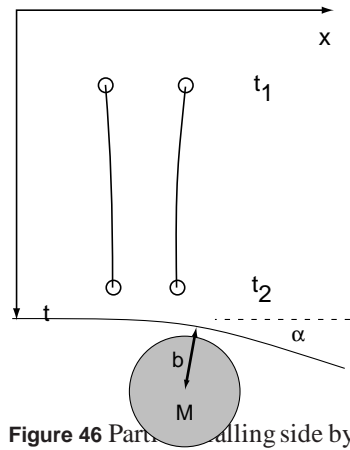

Figure 46 Particles falling side by side approach over time
Figure 47 Masses bend light



the same for all bodies, inertial mass is equal to (passive) gravitational mass, because in the relation $ma = \nabla(GMm/r)$ the left m is actually the inertial mass, and the right m is actually the gravitational mass.

But in the 17th century Galileo had already shown without a single experiment that the acceleration is indeed the same for all bodies. If larger masses fell more rapidly than smaller ones, the the following paradox would appear. Any body can be seen as composed from a large fragment attached to a small fragment. If small bodies really fell less rapidly, the small fragment would slow the large fragment down, so that the complete body would have to fall *less* rapidly than the larger fragment (or break into pieces). At the same time, the body being larger than its fragment, it should fall *more* rapidly than that fragment. This is obviously impossible: all masses must fall with the same acceleration.

Many accurate experiments have been performed after Galileo's original discussion. In all of them the independence of the acceleration of free fall on mass and material composition has been confirmed with the precision expected. In other words, as far as we can tell, the gravitational mass and the inertial mass are *identical*. What is the origin of this mysterious equality?

Ref. 93

This so-called 'mystery' is a typical example of disinformation, now common across the whole world of physics education. Let us go back to the definition of mass as negative inverse acceleration ratio. We mentioned that the physical origins of the accelerations do not play a role in the definition because it does not appear in the expression. In other words, the value of the mass is by definition independent of the interaction. That means in particular that inertial mass, based on electromagnetic interaction, and gravitational mass are identical *by definition*.

See page 60

Another beautiful proof of this statement was given by A.E. Chubykalo, and S.J. Vlaev. The total kinetic energy T of two bodies circling around their common centre of mass, like the earth and the moon, is given by $T = GmM/2R$, where the two quantities m and M are the *gravitational* masses of the two bodies and R their distance. From this expression, in which the inertial masses do *not* appear, they prove that the inertial and gravitational mass must be proportional to each other. Can you see how?

Ref. 94

No wonder that all measurements confirm this result. The issue is usually resurrected in general relativity, with no new results. 'Both' masses remain equal. Mass is a unique property of bodies. Another issue remains, though. What is the *origin* of mass? Why does it exist? This simple but deep question cannot be answered by classical physics.

Challenge 853

See page 249

Curiosities and fun challenges about gravitation

Fallen ist weder gefährlich noch eine Schande;
Liegen bleiben ist beides.*
Konrad Adenauer

■ Do all objects on earth fall with the same acceleration of 9.8 m/s^2 , assuming that air resistance can be neglected? No; every housekeeper knows that. You can check this by yourself. A broom angled at around 35 degrees hits the floor earlier than a stone, as the impact noises tell. Are you able to explain why?

Challenge 870

* 'Falling is neither dangerous nor a shame; to keep lying is both.' Konrad Adenauer (1876, Köln–1967, Rhöndorf), German chancellor.



▪ Both the earth and the moon attract bodies. The centre of gravity of the moon-earth system is 4800 km away from the centre of the earth, quite near its surface. Why do bodies on earth still fall towards the centre of the earth?

Challenge 887

▪ Does every spherical body fall with the same acceleration? No. If the weight of the object is comparable to that of the earth, the distance decreases in a different way. Can you confirm this statement? What then is wrong about Galileo's argument about the constancy of acceleration of free fall?

Challenge 904

▪ It is easy to lift a mass of a kilogram on a table. Twenty kilograms is tougher. A thousand is impossible. However, $6 \cdot 10^{24}$ kg is easy. Why?

Challenge 921

▪ The strength ratio between the tides of moon and sun is roughly $7/3$. Is it true that this is also the ratio between the mass densities of the two bodies?

Challenge 938

▪ The friction between the earth and the moon slows down the rotation of both. The moon stopped rotating already, and the earth is on its way. When the earth will have stopped rotating, the moon will stop moving away from earth. How far will the moon be at that time? Afterwards however, even more in the future, the moon will move back to the earth, due to the friction between the earth-moon system and the sun. Even though this effect would only take place if the sun burned forever, which is known to be false, can you explain it?

Challenge 955

▪ When one runs to the east, one *loses weight*. There are even two different reasons for this: the 'centrifugal' acceleration increases and thus the force with which we are pulled down diminishes, and the Coriolis force appears, with a similar result. Can you estimate the size of the two effects?

Challenge 972

▪ What is the time ratio between a stone falling through a distance l and a pendulum swinging through half a circle of radius l ? (This problem is due to Galileo.) How many digits of the number π can one expect to determine in this way?

Challenge 989

▪ Why can a spacecraft accelerate through the *slingshot effect* when going round a planet, despite momentum conservation?

Challenge 1006

Ref. 79

▪ The orbit of a planet around the sun has many interesting properties. What is the hodograph of the orbit? What is the hodograph for parabolic and hyperbolic orbits?

Challenge 1023

▪ A simple, but difficult question: if all bodies attract, why don't or didn't all stars fall towards each other?

Challenge 1040

▪ The acceleration g due to gravity at a depth of 3000 km is 10.05 m/s^2 , over 2% higher than at the surface of the earth. How is this possible? Also on the Tibetan plateau, g is higher than the sea level value of 9.81 m/s^2 , even though the plateau is more distant from the centre of the earth than sea level is. How comes?

Ref. 95

Challenge 1057

▪ When the moon circles the sun, does its path have sections concave towards the sun, as shown in the right part of the figure, or not, as shown on the left part?

Challenge 1074

▪ One can prove that objects attract each other (and that they are not attracted by the earth alone) with a simple experiment which everybody can perform at home, as described on the <http://www.fourmilab.ch/gravitation/foobar/> web site.

▪ It is instructive to calculate the *escape velocity* of the earth, i.e. that velocity with which a body must be thrown so that it never falls back. It turns out to be 11 km/s. What is

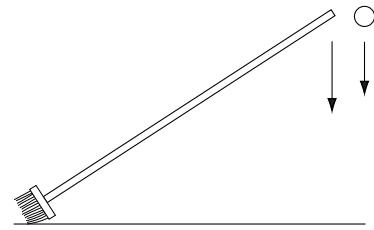

Figure 48 Brooms fall more rapidly than stones



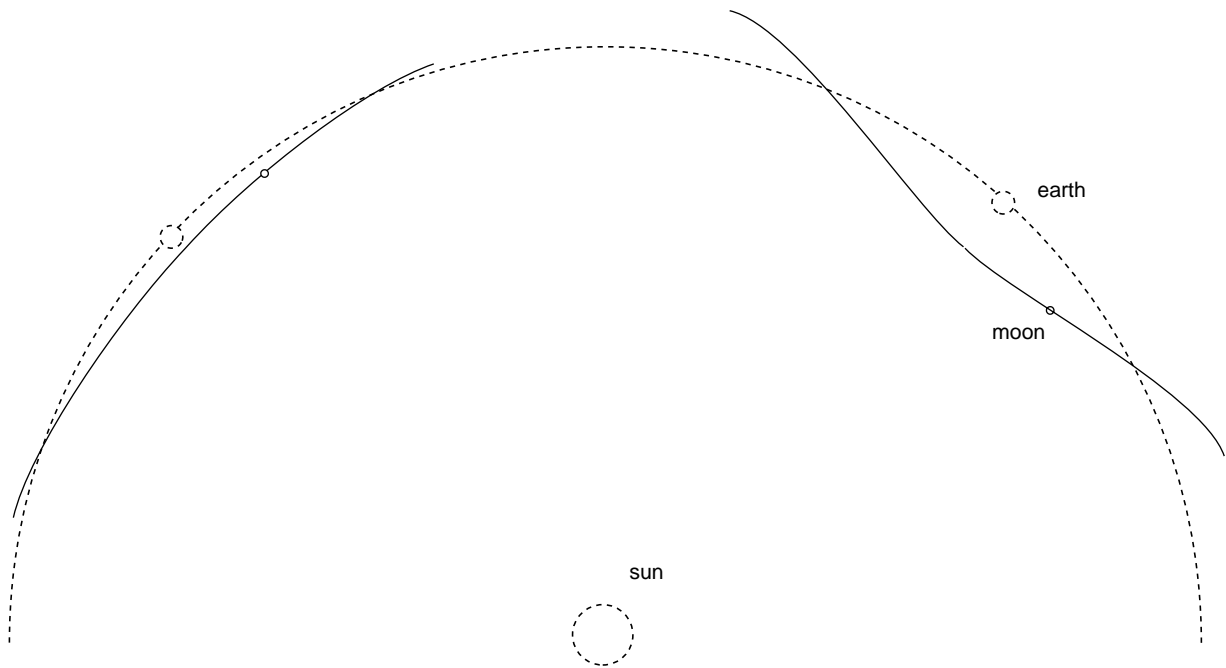

Figure 50 Which of the two moon paths is correct?

the escape velocity for the solar system? By the way, the escape velocity of our galaxy is 129 km/s. What would happen if a planet or a system were so heavy that its escape velocity was larger than the speed of light?

Challenge 1091

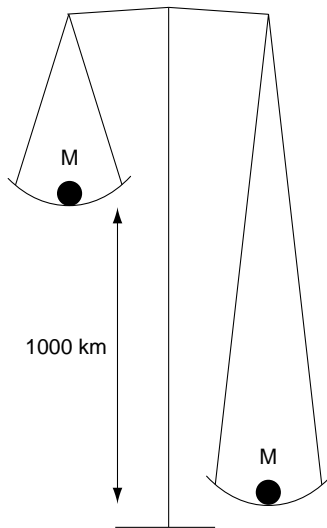

Figure 49 A honest balance?

- Can gravity produce repulsion? What happens to small test body on the inside of a large C-shaped mass? Is it pushed towards the centre of mass?

Challenge 1108

- For bodies of irregular shape, the centre of gravity of a body is *not* the same as the centre of mass. Are you able to confirm this? (Hint: find and use the simplest example possible.)

Challenge 4

- The *shape* of the earth is not a sphere. As a consequence, a plumb line usually does not point to the centre of the earth. What is the largest deviation in degrees?

Ref. 96

Challenge 21

- What is the largest asteroid one can escape from by jumping?

Challenge 38

- The constellation in which the sun stands at noon (at the centre of the time zone) is supposedly called the ‘zodiacal sign’ of that day. Astrologers say there are twelve of them, namely Aries, Taurus, Gemini, Cancer, Leo, Virgo, Libra, Scorpius, Sagittarius, Capricornus, Acquarius, and Pisces

and that each is a month long. Any check with a calendar shows that at present, the midday sun is never in the zodiacal sign during the days usually connected to it. The relation has shifted by about a month since it was defined, due to the precession of the earth’s axis. A

See page 77



check with a map of the star sky shows that the twelve signs do not have the same length, and that there are fourteen of them, not twelve (there is *Ophiuchus*, the snake, between Scorpius and Sagittarius, and *Cetus*, the whale, between Acquarius and Pisces). In fact, not a single astronomical statement about zodiacal signs is correct. To put it clearly, astrology, in contrast to its name, is *not* about stars.

Ref. 97

▪ The gravitational acceleration for a particle inside a spherical shell is zero. The vanishing of gravity in this case is independent of the particle shape and its position, and independent of the thickness of the shell.* Can you find the argument using the picture? This works only because of the $1/r^2$ dependence of gravity. Can you show that the result does not hold for non-spherical shells? Note that the vanishing of gravity inside a spherical shell usually does not hold if other matter is found outside the shell. How could one eliminate the effects of outside matter?

Challenge 55

Challenge 72

Challenge 89

Ref. 98

▪ There is no planet X, i.e. no tenth planet in our solar system outside Neptune and Pluto. But there are many small objects beyond them, in the so-called Kuiper belt and Oort cloud. Sometimes they change trajectory due to the attraction of a planet: that is the birth of a new comet.

▪ In astronomy many new examples of motion are still discovered. Sometimes there are also false alarms. One example was the alleged fall of *mini comets* on the earth. They were supposedly made of a few dozens of kilograms of ice and hitting the earth every few seconds. It is now known not to happen. On the other hand, it is known that many tons of asteroids fall on the earth every day, in the form of tiny particles. By the way, discovering objects hitting the earth is not at all easy. Astronomers like to point out that an asteroid as large as the one which led to the extinction of the dinosaurs could hit the earth without any astronomer noticing beforehand, if the direction is slightly unusual, such as from the south, where few telescopes are located.

Ref. 99

▪ Universal gravity allows only elliptical, parabolic, or hyperbolic orbits. It is impossible that a small object approaching a large one is captured. At least, that is what we have learned so far. Nevertheless, all astronomy books tell stories of capture in our solar system, e.g. about several outer satellites of Saturn. How is this possible?

Challenge 106

Challenge 123

Challenge 140

Can you see why?

Challenge 157

▪ Can the phase of the moon have a measurable effect on the human body? What about the tidal effects of the moon?

▪ There is an important difference between the heliocentric system and the old idea that all planets turn around the earth. The heliocentric system states that certain planets, such as Mars or Venus, can be *between* the earth and the sun at certain times, and *behind* the sun at

* This is a small example from the beautiful text by MARK P. SILVERMAN, *And yet it moves: strange systems and subtle questions in physics*, Cambridge University Press, 1993. It is a treasure chest for anybody interested in the details of physics.

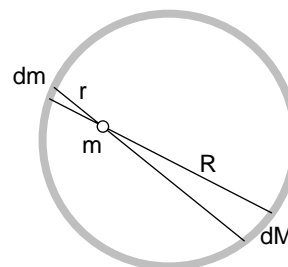

Figure 51 The vanishing of gravitational force inside a spherical shell of matter



other times. In contrast, the geocentric system states that they are always in between. Why did such an important difference not kill the geocentric system right away?

- The strangest reformulation of the description $m\mathbf{a} = \nabla U$ is the almost absurd looking Ref. 100

$$\nabla v = d\mathbf{v}/ds \quad (40)$$

where s is the motion path length. It is called the *ray form* of Newton's equation of motion. Can you find an example of its application? Challenge 174

- Seen from Neptune, the size of the sun is the same as that of Jupiter seen from the earth at the time of its closest approach.

- What will happen to the solar system in the future? This question is surprisingly hard to answer. The main expert of this topic, U.S. physicist Gerald Sussman, simulated a few hundred million years of evolution, on specially built computers, following only the planets, without taking into account the smaller objects. He finds that the planetary orbits are stable, but that there is clear evidence of chaos in the evolution of the solar system, at a small level. The various planets influence each other in subtle and still poorly understood ways. There is still a lot of research to be done in this field. Ref. 101
See page 163

- What is gravity? This simple question is not easy. Already in 1747 Georges-Louis Lesage proposed an explanation for the $1/r^2$ dependence. He argued that the world is full of small particles flying around randomly and hitting all objects. Single objects do not feel the hits, since they are hit continuously and randomly from all directions. But when two objects are near each other, they produce shadows for part of the flux to the other body, resulting in an attraction. Can you show that such an attraction has a $1/r^2$ dependence? The argument only works if the collisions are inelastic. Why? That would mean that all bodies would heat up with time, as Jean-Marc Levy-Leblond explains. Ref. 102
Challenge 191

This famous argument has resurfaced in physics regularly ever since, even though such particles have never been found. Only in the third part of our mountain ascent we will settle the issue. Ref. 1

- For which bodies does gravity decrease when approaching them? Challenge 208

- Could one put a satellite into orbit using a cannon? Does the answer depend on the direction in which one shoots? Challenge 225

- How often does the earth rise and fall when seen from the moon? Challenge 242

- What is the weight of the moon? How does it compare to the weight of the Alps? Challenge 259

- Due to the slightly flattened shape of the earth, the source of the Mississippi is about 20 km nearer to the centre of the earth than its mouth; the water effectively runs uphill. How can this be? Challenge 276

- If a star is made of high density material, the orbital speed of a planet circling it close by could be larger than the speed of light. How does nature avoid this strange possibility? Challenge 293

- One of the great mysteries of the solar system is the description of planet distances discovered in 1766 by Johann Daniel Titius (1729–1796) and publicized by Johann Elert Bode (1747–1826). Titius discovered that planet distances from the sun can be approximated by

$$d = a + b2^n \quad \text{with} \quad a = 0.4 \text{ AU}, \quad b = 0.3 \text{ AU} \quad (41)$$

when distances are measured in astronomical units. The resulting approximation is compared with observations in Table 95.



Planet	n	predicted distance in AU	measured distance in AU
Mercury	$-\infty$	0.4	0.4
Venus	0	0.7	0.7
Earth	1	1.0	1.0
Mars	2	1.6	1.5
Planetoids	3	2.8	ca. 2.2 to 3.2
Jupiter	4	5.2	5.2
Saturn	5	10.0	9.5
Uranus	6	19.6	19.2
Neptune	7	38.8	30.1
Pluto	8	77.2	39.5

Table 15 One of the mysteries of physics: planet distances and the values resulting from the Titius-Bode rule

Interestingly, the last three planets, as well as the planetoids, were discovered *after* Titius' death; the rule had successfully predicted Uranus' distance, as well as the planetoids. Despite these successes – and the failure for the last two planets – nobody has yet found a model for the formation of the planets which explains Titius' rule. Even more astonishing is the fact that it works also well for the distances of the various moons around Jupiter. Explaining it is one of the great challenges remaining in classical mechanics.

▪ In 1722, the great mathematician Leonhard Euler made a calculation mistake which led him to conclude that if a tunnel were built from one pole of the earth to the other, a stone falling into it would arrive at the earth's centre and then turn back up directly. Voltaire made fun of this conclusion for many years. Can you show that the real motion is an oscillation from one pole to the other, and can you calculate the time a pole-to-pole fall would take (assuming homogenous density)?

Challenge 310

What would be the time for a straight tunnel of length l , from surface to surface, not going from pole to pole?

Challenge 327

What is classical mechanics?

Given the mass of a body as its only permanent property, quite a few types of motion can be described. The study of these motion types is called *mechanics*, a name also given the experts studying the field. One can think of mechanics as the athletic part of physics; * like in athletics, also in mechanics one only measures lengths, times, and masses. In general, the part of physics in which observables are described by real numbers is called *classical*, in contrast to *quantum* physics. Taken in this sense, classical physics is the description which assumes that interactions between bodies can have arbitrarily small strengths. Thus all observables depending on space and time, such as field strengths, densities, currents, etc., are

* This is in contrast to the actual origin of the term 'mechanics', which means 'machine science'. It derives from the Greek μηχανή, which means 'machine' and even lies at the origin of the English word 'machine' itself. Sometimes the term 'mechanics' is used for the study of motion of *solid* bodies only, excluding e.g. hydrodynamics. This use has fallen out of favour in physics since about a century.



described with help of continuous (and commuting) functions of space and time. This is true even in the case of motion change due to contact. In physics, a classical description is possible only in the domains of mechanics, thermal physics, relativity, gravitation, and electromagnetism. Together they form the present, first part of our mountain ascent: classical physics.

As a consequence, the topic of this chapter is thus *classical mechanics*; the historical name is *Galilean physics* or *Newtonian physics*. The basis of classical mechanics is the description of motion only using space and time, such as $z(t) = z_0 + v_0(t - t_0) - \frac{1}{2}g(t - t_0)^2$, and is called *kinematics*. The main part of classical mechanics is the description of motion as a consequence of interactions between bodies and is called *dynamics*. The distinction of kinematics and dynamics can also be made in relativity, thermodynamics, and electrodynamics.

Even though we have not defined these fields of enquiry yet, we know that there is more to the world than gravity. A simple observation makes the point: friction. Can friction be due to gravity? No, since friction is not observed in the skies, who are governed by gravity.** Moreover, on earth, friction is independent of gravity, as you might want to check. There must be another interaction responsible for friction. We will study it shortly. But one issue merits a discussion right away.

Challenge 344

Should one use force?

Everybody has to take a stand on this question, even in physics. Indeed, many types of forces are used and observed in daily life. One speaks of muscular, gravitational, characterial, sexual, satanic, supernatural, social, political, economic, and many other types of forces. We call the different types of forces we observe between objects *interactions*. Later, the study of the details of all these forces will show that they are all composed of only four *fundamental* types of interactions: the gravitational, the electromagnetic and the two nuclear interactions.

But what is force? (*Physical*) *force* is defined as the *flow of momentum*, i.e. as

$$\mathbf{F} = \frac{d\mathbf{p}}{dt} . \quad (42)$$

Using the fact that in Galilean physics the linear momentum \mathbf{p} is defined as $\mathbf{p} = m\mathbf{v}$, one can rewrite the definition of force as

$$\mathbf{F} = m\mathbf{a} , \quad (43)$$

where $\mathbf{F} = \mathbf{F}(t, \mathbf{x})$ is the force acting on an object of mass m and $\mathbf{a} = \mathbf{a}(t, \mathbf{x}) = d\mathbf{v}/dt = d^2\mathbf{x}/dt^2$ is the acceleration of the same object, that is to say its change of velocity.* The

See page 255 ** This is not completely correct: in the 1980s, the first case of gravitational friction was discovered: the emission of gravity waves. We discuss it in detail later on.

* This equation was first written down by the Swiss mathematician and physicist Leonhard Euler (1707–1783) in 1747, over 70 years after Newton's first law and 20 years after Newton's death, to whom it is usually and falsely ascribed; it was Euler, not Newton, who first understood that this definition of force is useful in every case of motion, whatever the appearance, be it for point particles or extended objects, and be it rigid, deformable or fluid bodies. Surprisingly and in contrast to frequently made statements, equation (43) is even correct in relativity, as shown on page 200.



expression states in precise terms that force is what changes the *velocity* of masses. The quantity is called ‘force’ because it corresponds in many, but *not* all aspects to muscular force. For example, the more force is used, the further a stone can be thrown.

However, whenever the concept of force is used, it should be remembered that *physical force is different from everyday force or everyday effort*. Effort is probably best approximated by the concept of (*physical*) *power*, usually abbreviated P , and defined as

$$P = \frac{dW}{dt} = \mathbf{F} \cdot \mathbf{v} \quad (44)$$

Challenge 361 in which (*physical*) *work* W is defined as $W = \mathbf{F} \cdot \mathbf{s}$. You have mastered the definition of work and of energy once you can solve the following puzzle: what happens to the electricity consumption of an escalator if you walk on it instead of standing still?

Ref. 104 When students in exams say that the force acting on a thrown stone is smallest at the highest point of the trajectory, it is customary to say that they are using the so-called *Aristotelian view*, in which force is proportional to velocity, or even that they use a different concept of *state* of motion. It is then added with a tone of superiority that this view is all wrong. This is a typical example of intellectual disinformation. Every child knows from riding a bicycle, or from throwing a stone, or from pulling objects, that increased effort results in increased speed. The child is right; wrong are those theoreticians which translate this by saying that the child has a mistaken concept of *force*. In fact, the child or student is just using, instead of the *physical* concept of force, the *everyday* version, namely effort. Indeed, the effort exerted by gravity on a flying stone is smallest at the highest point of the trajectory. When one has understood the difference, including the strange consequence that a man walking carrying a heavy rucksack is not doing (almost) any work, one has taken the main hurdle in learning mechanics. **

Often equation (42) is not recognized as the definition of force. This is mainly due to the fact that there seem to be forces without any associated acceleration or momentum change, such as in a string under tension or in water of high pressure. Pushing against a tree, there is no motion, yet a force is applied. If force is momentum flow, where does the momentum go? It turns out that the same amount of momentum flows in both directions. One can show this by the slight deformations of both bodies, the arm and the tree. In fact, when one starts pushing and thus deforming, the associated momentum change of the molecules, the atoms, or the electrons of the bodies *is* observed. After the deformation is established, and looking at even higher magnification, one indeed finds that a continuous flow of momentum is going on in both directions. The nature of this flow will be studied in the part on quantum theory.

Since force is net momentum flow, it is needed as a separate concept only in everyday life, where it is useful in situations where net momentum flows are smaller than the total flows. At the microscopic level, momentum alone suffices for the description of motion. For the same reason, the concept of *weight*, also a force, will not be used (much) in our mountain ascent, which focuses on the fundamentals of motion.

Through its definition the concept of force is distinguished clearly from ‘mass’, from ‘momentum’, from ‘energy’, and from ‘power’. But where do forces originate from? In

** This stepping stone is so high that many professional physicists do not really take it themselves; this is witnessed by the innumerable comments in papers which state that physical force is defined using mass, and at the same time that mass is defined using force (the latter part of the sentence being a fundamental mistake).



other words, which effects in nature have the capacity to accelerate bodies by pumping momentum into objects? Table 16 gives an overview.

Situations which can lead to acceleration	Situations which only lead to deceleration	Motors and actuators
<i>piezoelectricity</i> quartz under applied voltage	thermoluminescence	walking piezo tripod
<i>gravitation</i> falling	emission of gravity waves	pulley
<i>collisions</i> satellite acc. by planet encounter growth of mountains	car crash meteorite crash	rocket motor swimming of larvae
<i>magnetic effects</i> compass needle near magnet magnetostriction current in wire near magnet	electromagnetic braking transformer losses electric heating	electromagnetic gun linear motor galvanometer
<i>electric effects</i> rubbed comb near hair bombs television tube	friction between solids fire electron microscope	electrostatic motor muscles, sperm flagella Brownian motor
<i>light</i> levitating objects by light solar sail for satellites	light bath stopping atoms light pressure inside stars	(true) light mill solar cell
<i>elasticity</i> bow and arrow bent trees standing up again	trouser suspenders pillow	ultrasound motor bimorphs
<i>osmosis</i> water rising in trees electro-osmosis	conservation of food with salt	osmotic pendulum variable X-ray screen
<i>heat & pressure</i> freezing champagne bottle tea kettle barometer earthquakes attraction of passing trains	surfboard water resistance quicksand parachute sliding resistance shock absorbers	hydraulic engines steam engine air gun, sail seismometer water turbine
<i>nuclei</i> radioactivity	plunging into sun	supernova explosion
<i>biology</i> bamboo growth	find example Challenge 378	molecular motors

Table 16 A selection of processes and devices changing the motion of bodies

Every example of motion, from the one which lets us choose the direction of our gaze to the one which carries a butterfly through the landscape, can be put into one of the two leftmost columns of Table 16.



Physically, the two columns are separated by the following criterion: in the first class, the acceleration of a body can be in a different direction than its velocity. The second class of examples only produces accelerations exactly *opposed* to the velocity of the moving body, as seen from the frame of reference of the braking medium. Such a resisting force is called *friction*, *drag*, or a *damping*. All examples in the second class are types of friction. Just check.

Challenge 395

Friction can be so large that all motion of a body against its environment is made impossible. In everyday life, this type of friction, called *static friction* or *sticking friction*, is common and important: without it, the turning wheels in bicycles, trains, and cars could not make them advance. Not a single screw would stay tightened. We could neither run nor walk in a forest, as every ice surface remind us during winter. In fact not only our own motion, but all *voluntary motion* of living beings is *based* on friction. The same is the case for self-moving machines. Without static friction, the propellers in ships, aeroplanes and helicopters would not be effective and the wings of aeroplanes would produce no lift to keep them in the air. In short, static friction is needed whenever one wants to move against the environment.

Once an object moves through its environment, it is hindered by another type of friction; this so-called *dynamic friction* between bodies in relative motion is also important. Without it, falling bodies would always rebound to the same height without ever stopping on the floor, neither parachutes nor brakes would work, nor would we have memory, as we will see later on.*

As the motion examples in the second column include friction, in those situations macroscopic energy is not conserved; the systems are *dissipative*. In the first column, macroscopic energy is constant; the systems are *conservative*.

The first two columns can also be distinguished using a more abstract, mathematical criterion: on the left are accelerations which can be derived from a potential, on the right, decelerations which cannot. Like in the case of gravitation, the description of any kind of motion is much simplified by the use of a potential: at every position in space, one needs only the single value of the potential to calculate the trajectory of an object, instead of the three values of the acceleration or the force. Moreover, the magnitude of the velocity of an object at any point can be calculated directly from energy conservation.

In the second class of processes this is impossible. These are the cases where one necessarily has to use force, if one wants to describe the details of the motion of the system. For example, the wind resistance of a body is *roughly* given by

$$F = 1/2c_w\rho Av^2 \quad (45)$$

where A is the area of its cross section, v its velocity relative to the air, ρ is the density of air, and c_w is a pure number, the *drag coefficient*, which depends on the shape of the moving object. You may check that aerodynamic resistance cannot be derived from a potential.*

Challenge 412

* For a general overview of the topic, from physics to economics, architecture and organizational theory, see N. AKERMAN, editor, *The necessity of friction – nineteen essays on a vital force*, Springer Verlag, 1993.

Recent research suggest that maybe in certain crystalline systems, such as tungsten bodies on silicon, under ideal conditions gliding friction can be extremely small and possibly even vanish – so-called ‘superlubrication’ – in certain directions of motion.

Ref. 105

* Such a statement about friction is correct only in three dimensions, as is the case in nature; in the case of a single dimension, a potential can *always* be found.

Challenge 429



ideal shape, $c_w = 0.0168$

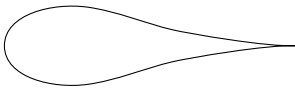

typical passenger airplane, $c_w = 0.03$



typical sports car, $c_w = 0.44$



Figure 52 Shapes and air resistance

where the more conservative estimate of 3% is used. An opposing wind speed of -2 m/s gives a time increase of 0.13 s, enough to change an a potential world record into an ‘only’ excellent result. (Are you able to deduce the c_w value for running humans from the formula?)

In contrast, static friction has different properties. It is proportional to the force pressing the two bodies together. Why? Studying the situation in more detail, sticking friction is found to be proportional to the actual contact area. It turns out that putting two solids into contact is rather like turning Switzerland upside down and putting it onto Austria; the area of contact is much smaller than the one estimated macroscopically. The important point is that actual contact area is proportional to the *normal* force. The study of what happens in the small percentage of contact area is still a topic of research; people investigate the issues using instruments such as atomic force microscopes, lateral force microscopes, and triboscopes.

These and all other examples of friction are accompanied by an increase in the temperature of the moving body. After the discovery of atoms, the reason became clear. Friction is not observed in few – e.g. 2, 3, or 4 – particle systems. Friction only appears in systems with many particles, usually millions or more. Such systems are called *dissipative*. Both the temperature changes and friction itself are due to motion of large numbers of microscopic particles against each other. This motion is not included in the Galilean description. When one does include it, friction and energy loss disappear, and potentials can then be used throughout. Positive accelerations – of microscopic magnitude – then also appear, and motion is found to be conserved. As a result, all motion is conservative on microscopic scale. Therefore, on microscopic scale it is possible to describe *all* motion without the concept of

** The topic of aerodynamic shapes is even more interesting for fluid bodies. They are kept together by *surface tension*. For example, surface tension keeps the hair of a wet brush together. Surface tension also determines the shape of rain drops. Experiments show that it is spherical for drops smaller than two millimetres, and that larger rain drops are *lens* shaped, with the flat part towards the bottom. The usual tear shape is *not* encountered in nature; something vaguely similar to it appears during drop detachment, but *never* during drop fall.

Ref. 106

The drag coefficient is found experimentally to always be larger than 0.0168, which corresponds to the optimally-streamlined tear shape. An aerodynamic car has a value of 0.25 to 0.3; but many sports cars share with trucks values of 0.44 and higher.**

Wind resistance is also of importance to humans, in particular in athletics. It is estimated that 100 m sprinters spend between 3% and 6% of their power overcoming drag. This leads to varying sprint times t_w when wind of speed w is involved, related by the expression

$$\frac{t_o}{t_w} = 1.03 - 0.03\left(1 - \frac{wt_w}{100}\right)^2, \quad (46)$$

Ref. 107

Challenge 446

Challenge 463

Ref. 108



force.* In conclusion, one should use force only in one situation: in the case of friction, and only when one does not want to go into the microscopic details.**

Complete states: initial conditions

Quid sit futurum cras, fuge quaerere ... ***
Horace, *Odi*, lib. I, ode 9, v. 13.

When the motion of a body is given by an expression such as

$$\mathbf{x}(\mathbf{t}) = \mathbf{x}_o + \mathbf{v}_o(t - t_o) + \frac{1}{2}\mathbf{a}_o(t - t_o)^2 + \frac{1}{6}\mathbf{j}_o(t - t_o)^3 + \dots \quad (47)$$

the quantities with an index o , such as $\mathbf{x}_o, \mathbf{v}_o$, etc., are called *initial conditions*. They are necessary to describe the motion one is investigating. We see directly from the equation that different systems have different initial conditions. Initial conditions specify the *individuality* of any particular system. We also see that that initial conditions allow us to distinguish the present situation of a system from those at previous times: initial conditions specify the *changing aspects* of a system.

See page 34 This is exactly the set of properties we required for a description of the *state* of a system. To find a complete description of states, we thus only need a complete description of initial conditions. Now it turns out that for gravitation, as well as all microscopic and several macroscopic interactions, there is *no* need for acceleration \mathbf{a}_o , jerk \mathbf{j}_o , or higher-order quantities. The reason is a property of nature: acceleration and jerk depend on the properties of objects alone, and do not depend on their past motion. For example, the expression $a = GM/r^2$ does not depend on the past at all, but only on the environment of the system. The same happens for the other interactions, as we will find shortly.

See page 56 The *complete* state of a moving mass point is thus described by specifying its position and its momentum for all instants of time. After a short study we have therefore achieved a rather complete description of point objects, namely by their mass, and of their states of motion, namely by their momentum, energy, position and time. For extended rigid objects, one also needs orientation, angular velocity, and angular momentum. Can you guess what is necessary in the case of fluids?

Challenge 480

The set of all possible states of a system is given a special name, because it is often useful to treat it as a single concept and to discuss its properties: it is called the *phase space*. We will use the concept repeatedly.

Challenge 497

However, there are situations in nature where the motion of an object depends on other characteristics than its mass; motion can depend on its colour (can you find an example?), on its temperature, and on a few other properties which we will soon discover. Can you give an example of an intrinsic property we have missed so far? And for each intrinsic property there are state variables to discover. We must therefore conclude that we do not have a complete description of motion yet.

Challenge 514

* The first scientist who eliminated force from the description of nature was Heinrich Rudolf Hertz (1857, Hamburg–1894, Bonn), the famous discoverer of electromagnetic waves, in his textbook on mechanics, *Die Prinzipien der Mechanik*, Barth, 1894, republished by Wissenschaftliche Buchgesellschaft, Darmstadt, 1963. His idea was strongly criticized at that time; only a generation later, when quantum mechanics quietly got rid of the concept for good, did the idea become commonly accepted. (Many have speculated about the role Hertz would have played in the development of quantum mechanics and general relativity, had he not died so young.)



It is interesting to recall the previous challenge and ask again: does the universe have initial conditions? Does it have a phase space? As a hint, recall that when a stone is thrown, the initial conditions summarize the effects of the thrower, his history, the way he got there etc.; in other words, initial conditions summarize the effects the environment had during the history of a system.

Challenge 531

An optimist is somebody who thinks that the future is uncertain.

Do surprises exist? Is the future determined?

Die Ereignisse der Zukunft *können* wir nicht aus den gegenwärtigen erschließen. Der Glaube an den Kausalnexus ist ein Aberglaube. *
Ludwig Wittgenstein, *Tractatus*, 5.1361

Freedom is the recognition of necessity.
Friedrich Engels (1820–1895)

If, after climbing a tree, one jumps down, one cannot stop the jump in the middle of the trajectory; once the jump is began, it is unavoidable and determined, like all passive motion. However, when one starts moving an arm, one can stop or change its motion from a hit to a caress. Voluntary motion does not seem unavoidable or predetermined. Which of these two cases is the general one?

Challenge 548

Let us start with the example we can describe most precisely so far: the fall of a body. Once the potential acting on a particle is given, by

$$\mathbf{a}(x) = -\nabla\phi = -GM\mathbf{r}/r^3 \quad (48)$$

and the state at a given time is given by initial conditions such as

$$\mathbf{x}(t_0) = x_0 \quad \text{and} \quad \mathbf{v}(t_0) = v_0 \quad , \quad (49)$$

we then can determine its motion, i.e. its complete trajectory $\mathbf{x}(t)$. Due to this possibility, an equation such as (48) is called an *evolution equation* for the motion of the object. (Note that the term ‘evolution’ has different meanings in physics and in biology.) An evolution equation always expresses the fact that not all types of change are observed in nature, but only certain specific cases. It expresses the fact that not all imaginable sequences of events are observed, but only a limited number of them. In particular, equation (48) expresses that from one instant to the next, objects change their motion based on the potential acting on

In his book, Hertz also formulated the principle of the straightest path: particles follow geodesics. This same description is one of the pillars of general relativity, as we will see later on.

** In the case of human relations the evaluation should be somewhat more discerning. A powerful book on human violence is JAMES GILLIGAN, *Violence – our deadly epidemic and its causes*, Grosset/Putnam, 1992.

Ref. 42 *** ‘What future be tomorrow, never ask ...’ Horace is Quintus Horatius Flaccus (65–8 BCE), the great Roman poet

* We *cannot* infer the events of the future from those of the present. Superstition is nothing but belief in the causal nexus.



them. Thus, given an evolution equation and initial state, the whole motion of a system is *uniquely fixed*; this property of motion is often called *determinism*. Since this term is often used with different meanings, let us distinguish it carefully from several similar concepts, to avoid misunderstandings.

Motion can be deterministic and at the same time *unpredictable*. The latter property can have four origins: an impracticably large number of particles involved, the complexity of the evolution equations, insufficient information on initial conditions, or strange shapes of space-time. The weather is an example where the first three conditions are fulfilled at the same time.* Nevertheless, its motion is still deterministic. In the case of black holes all four cases apply together. We will discuss black holes in the section on general relativity. Also their motion is still deterministic.

Motion can be both deterministic and time *random*, i.e. with different outcomes in similar experiments. A roulette ball's motion is deterministic, but it is also random.** As we will see later, quantum-mechanical situations fall into this category, as do all examples of irreversible motion, such as an ink drop spreading in clear water. In all such cases the randomness and irreproducibility are only apparent, and disappears when one includes description of states and initial conditions in the microscopic domain.

Challenge 565

A final concept to be distinguished from determinism is *acausality*. Indeed, it seems impossible to have deterministic motion (of matter and energy) which is *acausal*, i.e. faster than light. Can you confirm this? This topic will be deepened in the section on special relativity.

Saying that motion is ‘deterministic’ means that it is fixed in the future *and also in the past*. It is sometimes stated that predictions of *future* observations are the crucial test for a successful description of nature. Due to our often impressive ability to influence the future, this is not necessarily a good test. Any theory must, first of all, describe *past* observations correctly. It is our lack of freedom to change the past which results in our lack of choice in the description of nature that is so central to physics. In this sense, the term ‘initial condition’ is an unfortunate choice, because it automatically leads us to search for the initial condition of the universe and to look there for answers to questions which can be answered without that knowledge. The central ingredient of a deterministic description is that all motion can be reduced to an evolution equation plus one specific state, which can be either initial, intermediate, or final.

Challenge 582

To get a clear concept of determinism, it is useful to remind oneself why the concept of ‘time’ is introduced in our description of the world. We introduce time because we observe that first, we are able to define sequences among observations, and second, that unrestricted change is impossible. This is in contrast to movies, where one person can walk through a door and exit into another continent or century. Neither do we observe metamorphoses, such as people changing into toasters or dogs into toothbrushes. We are able to introduce ‘time’ only because the sequential changes we observe are extremely restricted. If nature were not reproducible, time could not be used. In short, determinism expresses the observation that

* For a beautiful view of clouds, see the <http://www.goes.noaa.gov> web site.

** Mathematicians have developed a large number of tests to determine whether a collection of numbers may be called *random*; roulette results pass these tests – in honest casinos only, however. Such tests typically check the equal distribution of numbers, of pairs of numbers, of triples of numbers, etc. Other tests are the χ^2 test and the Monte Carlo test.

Ref. 109



sequential changes are restricted to a single possibility.

Since determinism is connected to the use of the concept of time, new questions arise whenever the concept of time changes, as happens in special relativity, in general relativity, and in theoretical high energy physics. There is a lot of fun ahead.

In summary, every description of nature which uses the concept of time, such as that of everyday life, that of classical physics, and also that of quantum mechanics, is intrinsically and inescapably deterministic, since it connects observations of the past and the future, *eliminating* alternatives. In short, *the use of time implies determinism, and vice versa*. When drawing metaphysical conclusions, as is so popular nowadays when discussing quantum theory, one should never forget this connection. Whoever uses clocks but denies determinism is nurturing a split personality!*

See page 567

The idea that motion is determined often produces fear, because we are taught to associate it with lack of freedom. We do experience freedom in our actions and call it *free will*. We know that it is necessary for our creativity and for our happiness. Therefore it seems that determinism is opposed to happiness.

But what is free will precisely? Much ink has been consumed trying to find a precise definition. One can try to define free will as the arbitrariness of the choice of initial conditions. But this is impossible since initial conditions must themselves result from the evolution equations, so that there is in fact no freedom in their choice. One can try to define free will from the idea of unpredictability, or from similar properties, such as uncomputability. But all these definitions face the same problem: whatever the definition, there is *no way* to experimentally prove that an action was performed freely. In short, free will *cannot* be observed. (Psychologists also have a lot of their own data to underline this, but that is another topic.)

It is also clear from above that no process which is *gradual* – in contrast to *sudden* – has the chance to be due to free will; gradual processes are described by time and are deterministic. In this sense, the question about free will becomes one about the existence of sudden changes in nature. This will be a recurring topic in the rest of this walk. Does nature have the ability to surprise? In everyday life, nature does not. Sudden changes are not observed. Of course, we still have to investigate this question in other domains, in the very small and in the very large. Indeed, we will change our opinion several times. Note however that the concept of curiosity is based on the idea that everything discovered is useful afterwards. If nature continually surprised us, curiosity would make no sense.

In the beginning of our walk we defined time starting from the continuity of motion; later on we expressed this by saying that time is a consequence of the conservation of energy. A challenge remains: can you show that time would not be definable even if surprises existed only *rarely*?

Challenge 599

Given that there are no sudden changes, there is only one consistent definition of free will: it is a *feeling*, in particular of independence of others, of independence from fear, or of accepting the consequences of one's actions. Free will is a feeling of satisfaction. This solves the apparent paradox; free will, being a feeling, exists as a human experience, even though all objects move without any possibility of choice. There is no contradiction.*

Ref. 110

* That can be a lot of fun though.

* That free will is a feeling can also be confirmed by careful introspection. The idea of free will always appears *after* an action has been started. It is a beautiful experiment to sit down in a quiet environment, with the plan to make, within an unspecified number of minutes, a small gesture, such as closing a hand. If one carefully



Ref. 111
Challenge 633

Even if human action is determined, it still is authentic. So why is determinism so frightening? That is a question everybody has to ask himself. What difference does determinism imply for one's life, for the actions, the choices, the responsibilities, and for the pleasures one encounters? ** If one concludes that being determined is different from being free, one should change one's life! The fear of determinism usually stems from the refusal to take the world the way it is. Paradoxically, it is precisely he who insists on the existence of free will who is running away from responsibility.

You do have the ability to surprise yourself.
Richard Bandler and John Grinder

A strange summary about motion

Darum kann es in der Logik auch *nie* Überraschungen geben. ***
Ludwig Wittgenstein, *Tractatus*, 6.1251

Classical mechanics describes nature in a rather simple way. *Objects* are permanent and massive entities localized in space-time. *States* are changing properties of objects, described by position in space and instant in time, by energy and momentum, and by their rotational equivalents. *Time* is the relation between events measured by a clock. *Clocks* are devices in undisturbed motion whose position can be observed. *Space* and position is the relation between objects measured by a meter bar. *Meter bars* are devices whose shape is subdivided by some marks, fixed in an invariant and observable manner. *Motion* is change of position with time (times mass); it is determined, does not show surprises, is conserved (even in death), and is due to gravitation and other interactions.

Challenge 667

Even though this description works rather well, it contains a circular definition! Can you spot it? Each of the two central concepts of motion is defined with help of the other. Physicists had worked for about two hundred years on classical mechanics without noticing the fact. Even philosophers or other thinkers eager to discredit science saw it. Can an exact science be based on a circular definition? Obviously, physics has done quite well so far. Some even say the situation is unavoidable in principle. Despite these opinions, undoing this logical loop is one of the aims of the rest of our walk. To achieve it, we need to substantially increase the level of precision in our description of motion.

Challenge 684

Challenge 616

observes, in all detail, what happens inside oneself, around that very moment of decision, one finds either a mechanism which led to the decision, or a diffuse, unclear mist. One never finds free will. Such an experiment is a beautiful way to experience deeply the wonders of the self. Experiences of this kind might also be one of the origins of human spirituality, as they show the connection everybody has with the rest of nature.

Challenge 650

** If nature's 'laws' are deterministic, are they in contrast with moral or ethical 'laws'? Can people still be held responsible for their actions?
*** Hence there can *never* be surprises in logic.



4. Global descriptions of classical motion – the simplicity of complexity

Πλεῖν ἀνάγκη, ζῆν οὐκ ἀνάγκη.
 Navigare necesse, vivere non necesse.*
 Pompeius

Typeset in
 July 2002

The discovery of the universal law of gravity teaches an important lesson. All over the earth, even in Australia, people observe that stones fall ‘down.’ It is thus necessary to look for a description of gravity valid *globally*. It then is only a small additional step to deduce the result $a = GM/r^2$. In short, thinking globally provides an efficient way to increase the precision of motion description. How can we be as global as possible? It turns out there are six approaches to follow. Each of them is of help on our way to the top of Motion Mountain. We first give an overview of these approaches and present them in detail afterwards.

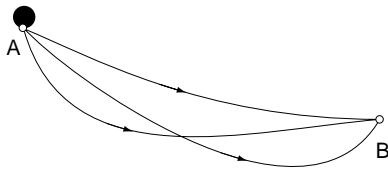

Figure 53 What shape of rail allows the black stone to glide most rapidly from point A to the lower point B?

▪ The first global approach is a reaction to a limitation of what we learned so far. Whenever we calculate the motion of a particle by calculating the acceleration it is subjected to, we are using the most *local* description of motion possible. Indeed, the acceleration at a certain place and instant of time only determines the position of the particle *just after* that moment and the motion *just following* that place.

Evolution equations thus have a mental horizon of radius zero. The opposite approach is shown in the famous question of Figure 53. The challenge is to find that path which allows the fastest motion between two points. The motion as a whole, for all times and positions, is sought.

Challenge 701

between two points. The motion as a whole, for all times and positions, is sought.

The global approach required by approaches such as this one will lead to a description of motion which is simple, powerful and fascinating.

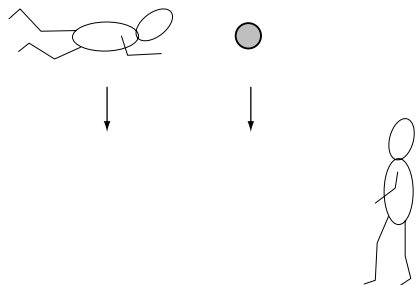

Figure 54 Can motion be described in a manner common to all observers?

▪ The second global approach to motion emerges when comparing the various descriptions produced by different observers of the same system. For example, observations by somebody falling from a cliff, a passenger in a roller coaster and an observer on the ground will usually differ. Studying their connections and finding a global description, valid for everybody, will lead us to the theory of relativity.

turn towards the investigations of *extended and rigid* bodies. Their motion can be surprising, as the experiment in Figure 55 shows. In addition, studying the interactions among several rigid bodies is essential for the design of machines. As an example, the mechanism in Figure 56 connects the motion of points C and P. It implicitly defines a circle such that

▪ The third way to look at motion globally is to

* ‘To navigate is necessary, to live is not.’ Gnaeus Pompeius Magnus (106–48 BCE), as cited by Plutarchus (ca. 45–ca. 125).



one always has the relation $r_C = 1/r_P$ for the distances r from its centre. Are you able to find that circle?

Challenge 718

Ref. 112

Another famous puzzle is to devise a wooden carriage, with gearwheels connecting the wheels to an arrow, so that whatever path the carriage takes, the arrow always points *south*. Such a device is useful in understanding general relativity, as we will see.

Challenge 735

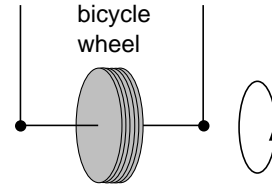

Figure 55 What happens when one rope is cut?

Ref. 113

A final example is the research into the way that human movements, such as the general motion of an arm, are built from a small number of basic motor primitives. These are a few fascinating topics of engineering; unfortunately, we won't have time to explore them in our hike.

▪ The description of *non-rigid extended bodies* is the fourth generalization of the study of motion. One part, *fluid mechanics*, studies the flow of honey, water, or air around solid bodies such as spoons, ships, sails, and wings. For example, it investigates how insects, birds and aeroplanes fly,* why sail boats can sail against the wind, what happens when a hard-boiled egg is made to spin on a thin layer of water, or how to empty a bottle full of wine in the fastest way possible.

Ref. 114

Challenge 752

The other part of the study of extended bodies, the behaviour of deformable *solid* bodies, is called *continuum mechanics*. It studies deformations and oscillations of extended bodies. Among others it explains why bells are made in the shape they are or where materials break when under load. We will mention a few issues from this field in special relativity and quantum theory.

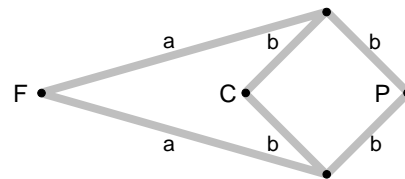

Figure 56 How to draw a straight line with a compass: fix point F, put a pencil into joint P, and move C with a compass along a circle

▪ A fifth general viewpoint, related to the preceding, arises when we ask for the motion of large numbers of particles. In these cases the study of motion is called *statistical mechanics*. We will visit it only briefly and introduce only those concepts we need for our further path.

* The mechanisms of insect flight are still a research subject. Traditionally, fluid dynamics concentrated on large systems like boats, ships and aeroplanes. Indeed, the smallest human-made object which can fly in a controlled way, say a radio controlled plane or helicopter, is much larger and heavier than what evolution was able to engineer. It turns out that there are many more tricks required and much more knowledge involved in letting small things fly than large things. More about this topic on page 660.



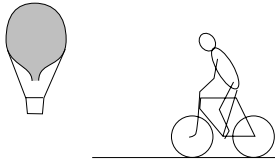

Figure 57 Why do balloons stay inflated? How do you measure the weight of a bicycle rider with a ruler only?

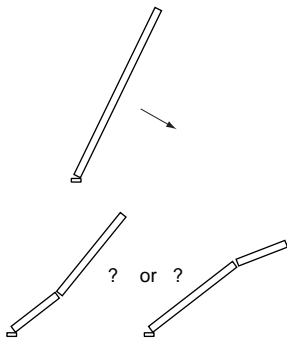

Figure 58 How and where does a falling brick chimney break?

▪ The sixth and final set of moving systems are those requiring for their description most of the mentioned viewpoints *at the same time*. Such systems form an important part of everyday experience, since *life* itself requires this approach. The formation of a specific number of petals in flowers, the differentiation of the embryo in the womb and the origin of the heartbeat in the human body are examples of such situations. Other examples are the emergence of mountains ridges and cloud patterns, or the formation of sea waves by the wind.

All these are examples of *growth processes*. Physicists speak of *self-organization*. Its topics are the spontaneous appearance of patterns, shapes and cycles. Self-organisation and growth are a common research theme across many sciences, from biology, chemistry and medicine to the geosciences and engineering.

In the following, we give a short introduction into these global descriptions of motion. We will start with the first of the six global descriptions just mentioned, namely the global description of moving point-like objects. This beautiful method, the result of several centuries of collective effort, is the highlight of mechanics. It also provides the basis for all further descriptions of motion we will encounter.

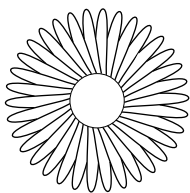

Figure 59 What determines the number of petals in a daisy?



The principle of least action

Motion can be described by numbers. For a single particle, the time dependence of coordinates does precisely that. Writing an expression $(x(t), y(t), z(t))$ for the path of a moving particle is one of the pillars of modern physics. In addition, motion is a type of change. Can change be described by numbers? Yes, it can. A single number is sufficient.

The way to *measure* change was discovered by chance, as a by-product of other studies. Physicists took almost two centuries to find it. Therefore the quantity measuring it has a strange name: it is called (*physical*) *action*.* To remember the connection of action with change, just think about Hollywood movies: a lot of action means that a lot is going on; a large action means a large amount of change.

We are now ready to define action. Imagine taking two snapshots of a system, and attempting to define the amount of change that occurred in between. When do things change a lot, and when do they change only a bit? First of all, a system with a lot of motion shows a lot of change. The action of a system is (usually) the sum of the actions of its subsystems. Secondly, change often builds up over time; in other cases, change can compensate some change which happened just before. Change can increase or decrease. Third, for a system in which motion is stored, transformed or shifted from one subsystem to the other, the change is smaller than for a system where this is not the case.

These properties leave only one possibility: change is measured by the average of kinetic minus potential energy, multiplied by the elapsed time. This product has all properties just mentioned: it (usually) is larger if the system is larger; the product generally builds up with time, except if the evolution compensates something that happened earlier; finally, the product decreases if the system transforms motion into potential energy.

Challenge 769

The so-called *action* S , measuring the change observed in a system, is thus defined as

$$S = \int_{t_i}^{t_f} (T - U) dt = \int_{t_i}^{t_f} L dt \quad . \quad (50)$$

See page 87

Let us explore the notation. T is the kinetic energy and U the potential energy we already know. Their difference L , a quantity also called the *Lagrangian (function)* of the system,** describes what is being added over time, whenever things change. The sign \int is a stretched ‘S’ for ‘sum’, is pronounced ‘integral of’ and designates the operation of adding up in tiny

* Note that the action measuring change is not the same as the ‘action’ appearing in sentences such as ‘action equals reaction.’ This last expression, coined by Newton, has not stuck; therefore the term has been recycled. It was first reused to mean something akin to the above. Later it was changed to the modern meaning used above. That is the only meaning used in the following.

Similarly, even the ‘principle of least action’ used to be different from the one of this chapter. The name has been recycled as well, to designate what was often called *Hamilton’s principle* in the Anglo-Saxon world, even though it is (mostly) due to others, primarily Leibniz. The old names and meanings are falling into disuse and are not used here.

Behind all these shifts in vocabulary is the story of a two-centuries-long, intense search to describe motion with so-called *extremal* or *variational principles*; the game was to complete and improve the work by Leibniz. These searches are only of historical value today, because all these historical principles are special cases of the one described here, which is the most general one, providing the key to all the others.

Ref. 115

** It is named after Giuseppe Luigi Lagrangia (Torino 1736–Paris 1813), better known as Joseph Louis Lagrange. He was the most important mathematician of his time. He developed most of the mathematical tools used nowadays for calculations in classical mechanics and classical gravitation.



Observation	Action value
Smallest measurable change	$0.5 \cdot 10^{-34} \text{ Js}$
Exposure of photographic film	$1.1 \cdot 10^{-34} \text{ Jsto} 10^{-9} \text{ Js}$
Wing beat of a fruit fly	ca. 1 pJs
Flower opening in the morning	ca. 1 nJs
Getting a red face	ca. 10 mJs
Held versus dropped glass	0.8 Js
Average tree bent by the wind from one side to the other	500 Js
Making a white rabbit vanish by 'real' magic	100 PJs
Hiding a white rabbit	ca. 0.1 Js
Maximum brain change in a minute	ca. 5 Js
Levitating yourself within a minute by 1 m	ca. 40 kJs
Car crash	ca. 2 kJs
Birth	ca. 2 kJs
Change due to a human life	ca. 1 EJs
Driving car stops within an eyelash	20 kJs
Driving car disappears within an eyelash	1 ZJs
Sun rise	ca. 0.1 ZJs
Large earthquake	ca. .. Js
Gamma ray burster before and after explosion	ca. 10^{56} Js
Universe after one second has elapsed	undefined, as universe is not a physical system

Table 17 Some action values for changes either observed or imagined



time steps dt . The initial and the final times are written below and above the integration sign. The adding up operation, called *integration*, thus simply means the measurement of the grey area shown in Figure 60.

We can see integration also as an abbreviation, namely

Challenge 786

$$\int_{t_i}^{t_f} L(t) dt = \lim_{\Delta t \rightarrow 0} \sum_{m=i}^f L(t_m) \Delta t \quad (51)$$

defining it as the sum one gets when the time slices get as small as possible.* Since the Σ sign also means a sum, and since a tiny Δt is written dt , we can understand why integration is written the way it is. Remembering these meanings will allow you to understand every formula with integration sign you will ever see. Also this ingenious notation, by the way, is due to Leibniz. Physically, the integral measures the *effect* that L builds up over time. Indeed, the action is called ‘effect’ in other languages, such as German. It is then said that the action is the integral of the Lagrangian over time.

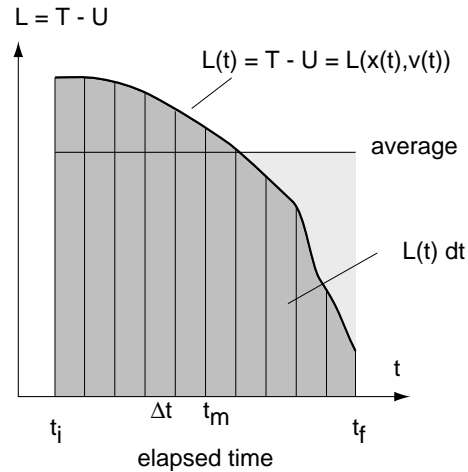

Figure 60 Defining a total effect by adding up over time

The unit of action, and thus of physical change, is therefore the unit of energy, the Joule, times the unit of time, the second. Change is measured in Js. A large value means a big change. Some examples are given in Table 115.

To understand the definition of action, let’s first take the simplest case; we take a system for which the potential energy is zero, such as a particle moving freely. Obviously, a large kinetic energy means lots of motion. If we observe the particle at time t_i and again at time t_f , the more distant the initial and the final instants, the larger the change. In addition, the observed change is larger if the particle moves more rapidly, as its kinetic energy is larger.

Now take the next case: assume that there is a potential involved. For example, a falling particle exchanges potential energy for kinetic energy during its motion. The more energy is exchanged, the less change there is. Hence the minus sign in the definition of L .

When drawing the curve for $L(t)$ in the case of free fall, we find that the definition of integration makes us count the grey surface *below* the time axis *negatively*. This allows the compensation of previously build up change, as we expected.

Change can also be measured for a system made of several components. We simply add all kinetic and subtract all potential energies. This allows us to define actions even for gases, liquids, and solid matter. In short, action is an *additive* quantity.

The action thus measures all changes observed in a system between two instants using a single number. Whatever happens, be it an explosion, a caress or a colour change, one number is sufficient. We will discover that this approach is also possible in relativity and quantum theory. Any change going on in a system can be measured by a single number.

* Of course, there are more details to integration. They can be found in Appendix D.



Now that we have defined a precise method to measure change, we can specify the way in which it allows the description of motion. In nature, the change happening between two instants is always the *smallest* possible. *In nature, action is minimal.** Nature always chooses that trajectory, that path or that way to move among all possible and imaginable ones for which the change is *minimal*. Let us study a few examples.

In the simple case of a free particle, when no potentials are involved, the principle of minimal action implies that it moves in a *straight* line with *constant* velocity. All other paths would lead to larger actions. Can you confirm this?

Challenge 803

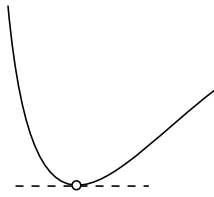

Figure 61 The minimum of a curve has vanishing slope

Similarly, a thrown stone flies along a parabola, – or more precisely, along an ellipse, as we found out – because any other path, say one in which the stone makes a loop in the air, would imply a *larger* action. You might want to check for yourself that such a weird stone would not keep change to a minimum.

Challenge 820

All observations confirm the simple statement: things always move producing the smallest possible value for the action. The statement applies to the complete path and to every of its small parts.

It is customary to express the idea of minimal change in the following way. The action varies when the path is varied. You remember from high school that at a minimum, the variation of a quantity vanishes; a minimum has a horizontal slope. In the present case, we do not vary a variable, we vary complete paths; hence we do not say slope, but variation and write it δS .

The *principle of least action* thus states:

$$\triangleright \text{The actual trajectory between specified end points is given by } \delta S = 0. \quad (52)$$

Mathematicians call this a *variational principle*. The end points are mentioned to make clear that for the comparison of actions we have to compare motions with the same initial and final situations.

Before we discuss the result, we check that the principle is equivalent to the evolution equation. We will see that this is always the case if motion is described with sufficient precision.** The equivalence is always shown in the same, standard procedure. (This procedure is part of the so-called *calculus of variations*.) To start with, the condition $\delta S = 0$ implies

* In fact, in some rare, academic situations the action is maximal, so that the snobbish form of the principle states that the action is ‘stationary,’ or an ‘extremum,’ meaning minimal *or* maximal. The condition of vanishing variation encompasses both cases.

** There are a few comments to be made, for those interested in the topic, on the equivalence of Lagrangians and evolution equations. Otherwise just skip this note. First of all, Lagrangians do not exist for non-conservative, or *dissipative* systems. In other words, for any motion involving *friction*, as there is no potential, there is no action. One way out is to use a generalized formulation of the principle of least action. Whenever there is no potential, we can express the *work* variation δW between different trajectories as

$$\delta W = \sum_i m_i \ddot{x}_i \delta x_i \quad . \quad (53)$$

Motion is then described in the following way:

$$\triangleright \text{The actual trajectory is given by } \int_{t_i}^{t_f} (\delta T + \delta W) dt = 0 \quad \text{provided} \quad \delta x(t_i) = \delta x(t_f) = 0 \quad . \quad (54)$$

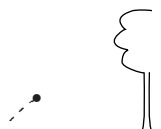

Challenge 854 that the action, i.e. the grey area under the curve, is a minimum. A little bit of thinking shows that a Lagrangian $L(x_n, v_n) = T(v_n) - U(x_n)$ implies that all motion follows

$$\frac{d}{dt} \left(\frac{\partial T}{\partial v_n} \right) = \frac{\partial U}{\partial x_n} \quad (55)$$

Challenge 871 where n counts all coordinates of all particles. * For a single particle, these *Lagrange's equations of motion* reduce to

$$m\mathbf{a} = \nabla U \quad . \quad (57)$$

Challenge 888 This is the original evolution equation; the principle of least action thus implies the equation of motion. (Can you show the converse?)

In other words, *all systems evolve in such a way that the necessary change is as small as possible*. Nature is economic. Nature is thus the opposite of a Hollywood thriller, where the action is maximized; nature is more like a wise old man who keeps his actions to a minimum. Or, if you prefer, nature is a Dr. Dolittle.

Challenge 837 The quantity being varied has no name; it could be called a generalized version of change. You might want to check that it leads to the correct evolution equations. In other words, *proper* Lagrangian descriptions exist only for *conservative* systems; however, for dissipative systems the principle can be generalized and remains useful.

Physicists will disagree with this classification and prefer another way out. What a mathematician calls a generalization is a special case for a physicist; principle (54) hides that *all* friction derives from the usual principle of minimal action, if we include the complete microscopic details. There is no friction in the microscopic domain. Friction is an approximate concept.

Nevertheless, additional, more mathematical viewpoints are useful; for example, they lead to interesting discoveries such as further limitations on the use of Lagrangians. These limitations, which apply only if the world is viewed as purely classical – which it isn't – were discovered in times when computers were not available, and when such studies were fashionable. Here are a few results.

Ref. 116 The generalized coordinates used in Lagrangians are not necessarily the Cartesian ones. Generalized coordinates are especially useful when there are *constraints*, such as in the case of a pendulum, where the weight always has to be at the same distance from the suspension, or in the case of an ice skater, where the skate has to move in the direction it is pointing. Generalized coordinates may even be mixtures of positions and momenta. They can be divided into a few general cases.

See page 150 Generalized coordinates are called *holonomic-scleronomic* when they are related to Cartesian coordinates in a fixed way, independently of time; the pendulum is an example, as is a particle in a potential. Coordinates are called *holonomic-rheonomic* when the dependence involves the situation itself, such as the case of an ice skater who can move only along the skates, not perpendicular to them. The two terms rheonomic and scleronomic are due to Ludwig Boltzmann.

See page 107 The more general situation is called *anholonomic*; the term is due, like the term holonomic, to Heinrich Hertz. Lagrangians work well only for holonomic systems.

To sum up, even though the use of Lagrangians and of action has its limits, they do not bother us, since microscopic systems are always conservative, holonomic and scleronomic. We therefore can continue our walk with the result that for fundamental examples of motion, evolution equations and Lagrangians are indeed equivalent. * The most general form for a Lagrangian $L(q_n, \dot{q}_n, t)$, using generalized coordinates q_n , leads to Lagrange equations of the form

$$\frac{d}{dt} \left(\frac{\partial L}{\partial \dot{q}_i} \right) = \frac{\partial L}{\partial q_i} \quad . \quad (56)$$

In order to deduce them, we also need the relation $\delta \dot{q} = d/dt(\delta q)$; it is valid only for the *holonomic* coordinates introduced above and explains their importance.

Ref. 117 It should also be noted that the Lagrangian for a moving system is not unique; however, the study of how the various Lagrangians for a given moving system are related is not part of this walk.



The principle of minimal action also states that the actual trajectory is the one for which the *average* of the Lagrangian over the whole trajectory is minimal. The graph also shows the connection. Can you confirm it? This way to look at the action allows to deduce Lagrange's equations (55) directly.

Challenge 905

The description of motion with the principle of least action thus distinguishes the actual trajectory from all other imaginable ones. This fact led to Leibniz's famous interpretation that the world is the 'best of all possible worlds.'* We may dismiss this somewhat metaphysical speculation, but not the inherent fascination of the result. Leibniz was so excited about it because expression (52) was the first example of a description of nature which singled out observations from all other imaginable possibilities. For the first time the search for reasons why things are not different from what they are became a part of physical investigation. The deep underlying question is: could the world be different from what it is? What do you think? At the present point, we have a hint *against* this possibility. A final answer to this question will emerge only in the last part of our adventure.

Challenge 922

Compared to description of motion with evolution equations, description with a Lagrangian has several advantages. First of all, it is usually more *compact* than writing the corresponding evolution equations. For example, only *one* Lagrangian is needed for one system, *independently* of the number of particles. One also makes fewer mistakes, especially sign mistakes, as one rapidly learns when performing calculations: just try to write down the evolution equations for a chain of masses connected by springs, and then compare the effort with a derivation using a Lagrangian. We will discover another example shortly: David Hilbert took only a few weeks to deduce the equations of motion of general relativity using a Lagrangian, after Albert Einstein had worked for ten years searching for them directly.

Challenge 939

In addition, the description with a Lagrangian is valid with *any* type of coordinates describing the objects of investigation. Coordinates do not have to be Cartesian, they can be chosen as one prefers, cylindrical, spherical, hyperbolic, etc. The advantage of using these so-called *generalized coordinates* will not be studied in our walk; they allow one to rapidly calculate the behaviour of many mechanical systems which are too complicated to be described with Cartesian coordinates. For example, for the programming of the motion of robot arms, joint angles provide a clearer description than Cartesian coordinates of arms ends. Angles are non-Cartesian coordinates. They simplify calculations considerably, such as the task of finding the most economical way to move the hand of a robot from one point to the other.

More importantly, the Lagrangian allows one to quickly deduce the key properties of a system, namely its *symmetries* and its *conserved quantities*. We will develop this important ability shortly, and then use it regularly throughout our walk.

See page 133

Finally, the Lagrangian formulation can be generalized to encompass *all types of interactions*. The concepts of kinetic and potential energy are interaction independent. Indeed, the principle of least action can also be used in electricity, magnetism, and optics. It is central to general relativity and to quantum theory, and allows one to easily relate both fields to classical mechanics.

* This idea was ridiculed by the French philosopher Voltaire (1694–1778) in his lucid writings, notably in the brilliant book *Candide ou l'optimisme*, 1759, available in paperback from Folio-Gallimard, 1992.



When the principle of least action became well-known, people applied it to an ever-increasing number of problems. Today, Lagrangians are used in everything from the study of elementary particle collisions to the programming of motion in artificial intelligence. However, we should not forget that despite its simplicity and usefulness, the Lagrangian formulation is *equivalent* to the original evolution equations. It is neither more general nor more specific. In particular, it is *not an explanation* for any type of motion, but only a different view of it. In fact, the correspondence is so close that we can say that the search of a new physical ‘law’ of motion is ‘simply’ or ‘only’ the search for a new Lagrangian. This is not a surprise, as the description of nature requires the description of change, and change is described by actions and Lagrangians.

Challenge 956

Even though the principle of least action is not an explanation, it calls for one. We need some patience, though. *Why* nature follows the principle of least action and *how* it realizes it will become clear in the part on quantum theory.

Why is motion so often bound?

The optimist thinks this is the best of all possible worlds,
and the pessimist knows it.
Robert Oppenheimer

Looking around oneself on earth and in the sky, we find that matter is not evenly distributed. Matter tends to be near other matter; it is lumped together in *aggregates*, of which the main ones are listed in Figure 62 and Table 18. Obviously, the stronger the interaction, the smaller the aggregate. But why is matter mainly found in lumps at all?

Ref. 120

First of all, aggregates form because of the existence of *attractive* interactions between objects. Secondly, they stay together because of *friction*, that is to say because the energy released when the objects approach can be changed into heat, which prevents the objects from leaving again. Thirdly, aggregates exist because of *repulsive* effects which prevent the components from collapsing completely. Together, these three characteristics ensure that bound motion is much more frequent than unbound, ‘free’ motion.

See page 531

Only three types of attractions lead to aggregates: gravity, the electric interaction, and the strong nuclear interaction. Similarly, only three types of repulsive effects are observed: rotation, pressure, and the Pauli exclusion principle (which we will encounter later on). Of the nine combinations, only some appear in nature. Can you find out which ones are missing from Figure 62 and Table 18, and why?

Challenge 990

Together, attraction and friction imply that change and action are minimized when objects come and stay together. The principle of least action thus implies the stability of aggregates. By the way, the same arguments also explain why so many aggregates *rotate*. Can you provide the connection?

Challenge 1007

But why does friction exist at all? And why do attractive and repulsive interactions exist? Or repulsive ones? In addition, the above answers assume that in some distant past matter was *not* found in lumps. Is this correct? In order to find out, we must first study another global property of motion.



This is a section of the freely downloadable e-textbook

Motion Mountain

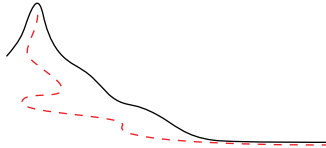

Hiking beyond space and time along the concepts of modern physics

available at
www.motionmountain.org

Copyright © 1997, 1998, 1999, 2000, 2001, 2002 by Christoph Schiller

To the kind reader

In exchange for getting this section for free, I ask you for a short email on some of the following:

Challenge 973

- Which page was boring?
- Did you find any mistakes?
- What else were you expecting?
- What was hard to understand?

Of course, any other suggestion is welcome. This section is part of a physics text written over many years. The text lives and grows through the feedback from its readers, who help to improve and to complete it. For a particularly useful contribution (send it in english, italian, dutch, german, spanish, portuguese, or french) you will be mentioned in the foreword of the text, or receive a small reward, or both.

Enjoy!

Christoph Schiller
cs@motionmountain.org



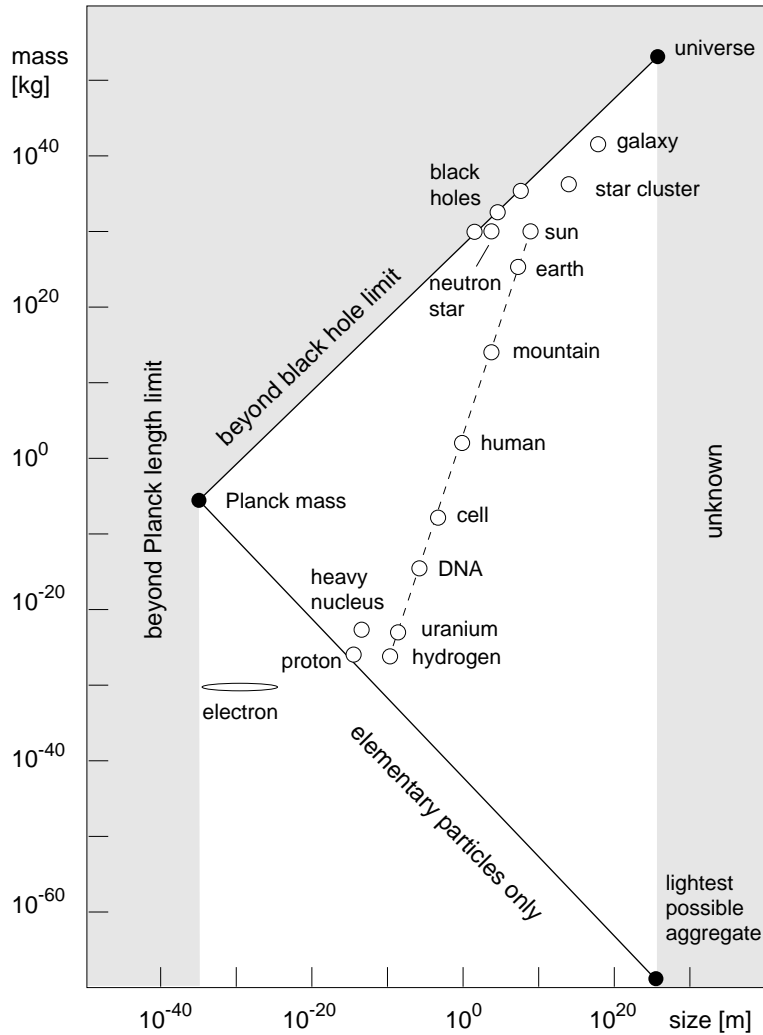
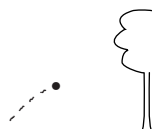

Figure 62 Aggregates in nature

Table 18 The main aggregates observed in nature

Interaction aggregate	size (diameter)	observed number	constituents
gravitationally bound aggregates			
matter across universe	ca. 100 Ym	1	photons, hydrogen and helium atoms, galaxy super clusters
quasar		$20 \cdot 10^6$	baryons and leptons
galaxy supercluster	ca. 3 Ym	10^6	galaxy groups
galaxy group/cluster	ca. 100 Zm	10^8	10 to 1000 galaxies
our galaxy group	50 Zm	1	ca. 20 galaxies
general galaxy	0.5 to 2 Zm	10^{10}	10^{10} stars, dust
our galaxy	1.0(0.1) Zm	1	10^{10} stars, solar systems, clouds
interstellar clouds	ca. 1 PM	$\gg 10^5$	hydrogen, ice and dust



Interaction aggregate	size (diameter)	observed number	constituents
solar system ^a	30 Tm	ca. 1	sun, planets, moons, comets, asteroids, gas, dust
Oort cloud	6 to 30 Pm	1	comets, dust
Kuiper belt	60 Tm	1	comets, dust
Pluto's orbit	11.8 Tm		
star ^b	10 km to 100 Gm	10 ^{22±1}	ionized gas: protons, neutrons, electrons, neutrinos, photons
neutron stars (with gravity)	10 km	ca. 1000	neutrons
our star	1.39 Mm		
planet ^a (Jupiter, Earth)	143 Mm, 12.8 Mm	ca. 9	solids, liquids, gases; in particular, heavy atoms
moons	10 - 1000km	ca. 50	solids
electromagnetically bound aggregates^c			
asteroids, mountains ^d	1 m to 930 km	10 ⁹	solids
comets	10 cm to 50 km	10 ^{...}	ice and dust
planetoids, solids, liquids, gases, cheese	1 nm to > 100 km	n.a.	molecules, atoms
animals, plants, kefir	5 μm to 1 km	10 ^{...}	organs, cells
brain	0.15 m	10 ¹⁰	neurons and other cell types
cells		10 ^{28±2}	organelles, membranes, molecules
smallest: (...)	ca. 5 μm		molecules
amoeba	600 μm		molecules
largest: (whale nerve, single cell plants)	ca. 30 m		molecules
molecules		ca. 10 ^{78±2}	atoms
H ₂	ca. 50 pm		atoms
DNA (human)	2 m (total)		atoms
atoms, ions	30 pm to 300 pm	10 ^{80±2}	electrons and nuclei
aggregates bound by the weak interaction ^c			
none			
aggregates bound by the strong interaction ^c			
nucleus	> 10 ⁻¹⁵ m	10 ^{79±2}	nucleons
nucleon (proton, neutron)	ca. 10 ⁻¹⁵ m	10 ^{80±2}	quarks
mesons	ca. 10 ⁻¹⁵ m	n.a.	quarks

a. Only in the year 1994 was the first evidence found for objects circling other stars than our sun; most of the over 70 *extrasolar planets* found so far were found around F, G, and K stars, including neutron stars. For example, three objects circle the pulsar PSR1257+12 and a matter ring circles the star β Pictoris. The objects seem to be dark stars, brown dwarfs or large gas planets like Jupiter. None of the systems found so far form solar systems of the type we live in.

Ref. 121

b. The sun is among the top 5% stars, when ranked in brightness. Most fainter stars, namely 70%, are red M dwarfs, 15% are orange K dwarfs, and 10% are white dwarfs. However, almost all stars in the night sky belong to the bright 5%. These are from the rare blue O class or blue B class such as Spica, Regulus and Riga; 1% consist of the bright, white A class such as Sirius, Vega and Altair, and of the yellow-white F class such as Canopus, Procyon and Polaris; 4% are of the yellow G class, like Alpha

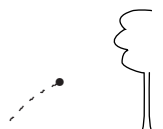

See page 300 Centauri, Capella or the sun. Exceptions are the few K giants, such as Arcturus and Aldebaran, and the M supergiants, such as Betelgeuse and Antares. More on stars later on..
 c. For more details on *microscopic* aggregates, see the table of composites in Appendix C.
 d. It is estimated that there are about 10^9 asteroids (or planetoids) larger than 1 km and about 10^{20} heavier than 100 kg.

Ref. 122

Curiosities and challenges about Lagrangians

Lagrangians are a fascinating topic.

- When Lagrange published his book *Mécanique analytique*, in 1788, it formed one of the high points in the history of mechanics. He was very proud of having written a systematic exposure of mechanics without a single figure. Obviously the book was difficult to read and was not a sales success. Therefore his methods took another generation to come into general use.

- Given that action is the basic quantity describing motion, we can define energy as action per time, and momentum as action per distance. The *energy* of a system thus describes how much it changes over time, and the *momentum* how much it changes over distance. What are angular momentum and rotational energy?

Challenge 1024

- Effects by telekinesis or praying are impossible, as in most cases the change inside the brain is usually much smaller than the changes claimed in the outside world. Is the argument correct?

Challenge 1041

- In Galilean physics, the Lagrangian is given by the difference between kinetic and potential energy. Later on, this definition will be generalized in a way that sharpens the understanding of this distinction: the Lagrangian becomes the difference between a term for free particles a term due to their interactions. In other words, particle motion is a continuous compromise between what the particle would do if it were free and what other particles want it to do. In this, particles behave a lot like humans beings.

- In nature, the sum $T + U$ of kinetic and potential energy is *constant* during motion (for closed systems), whereas the average of the difference $T - U$ is *minimal*. Is it possible to deduce, by combining the two expressions, that systems tend to a minimum potential energy?

Challenge 1058

- There is a principle of *least effort* describing the growth of trees. When a tree grows, all the mass it consists of has to be lifted upwards from the ground. A tree does this in such a way that it gets the best possible result, which means as many branches as high up in the air as possible using the smallest amount of energy.

- Another minimum principle can be used to understand the construction of animal bodies, especially their size and the proportions of their inner structures. For example, the heart pulse and breathing frequency both vary with animal mass as $m^{-1/4}$, and the dissipated power as $m^{3/4}$. It turns out that such exponents result from three properties of living beings. First, they transport energy and material through the organism via a branched network of vessels: a few large ones, and increasingly more the smaller they are. Second, the vessels all have a universal minimum size. And third, the networks are optimized in order to minimize the energy needed for transport. Together, these relations explain many additional scaling rules; they might also explain why animal life span scales as $m^{-1/4}$, or that most mammals have roughly the same number of heart beats.

Ref. 118



A competing explanation, using a different minimum principle, states that water powers arise in any network built so that the flow arrives to the destination by the most direct path.

Ref. 119

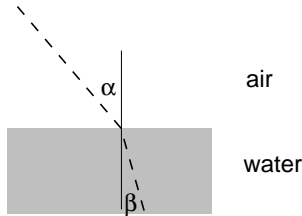

Figure 63 Refraction of light is due to travel time optimization

▪ The minimum principle for the motion of light is even more beautiful; light always takes the path which requires the shortest travel time. It was found already long ago that this idea describes exactly how light changes direction when it moves from air to water. In water, light moves more slowly; the speed ratio between air and water is called the refractive index n of water. Its value is about 1.3. This speed ratio, together with the minimum time principle, leads to the ‘law’ of refraction, a simple relation between the sine of the two angles. Can you deduce it? In fact, the exact definition of the refractive index is with respect to vacuum, not to air. But the difference is negligible; can you imagine why?

Challenge 1075

Challenge 1092

For diamond, the refractive index is 2.4. The high value is one reason for the sparkle of diamonds with the so-called *brilliant* cut. Can you specify some additional reasons?

▪ Are you able to confirm that each of these minimum principles are special cases of the principle of least action? In fact this is true for *all* known minimum principles in nature. Each of them, like the principle of least action, is a principle of least change.

Challenge 1109

▪ In Galilean physics, the value of the action depends on the observer. It is the same for observers with different orientations and positions, but not the same for observers with different speeds. What does special relativity require? How will the action look in that case?

Challenge 5

▪ Measuring all change going on in the universe presupposes that the universe is a system. Is that correct?

Challenge 22

Motion and symmetry

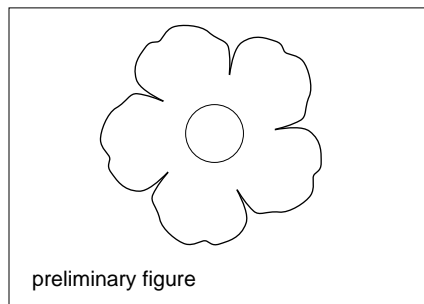

Figure 64 Forget-me-not, also called *myosotis* (Borraginaceae)

Different points of view imply different observers; in physics, the viewpoints are often called *frames of reference* and are described mathematically by coordinate systems.

The second way to describe motion globally is to describe it in such a way that all observers *agree*. An object under observation is called *symmetric* if it looks the same when seen from different points of view. For example, the forget-me-not of Figure 64 is symmetrical because it looks the same after turning around it by 72 degrees; many fruit tree flowers have the same symmetry. One also says that under change of viewpoint the flower has an *invariant property*, namely its shape. If there are many such viewpoints one talks about a *high* symmetry, otherwise a *low* symmetry. For example, a four-leaf clover has a higher symmetry than a usual, three-leaf one.

At first sight, not many objects or observations in nature seem to be symmetrical. But this is a mistake due to a too-narrow interpretation of the term. On the contrary, we can deduce that nature as a whole is symmetric from the simple fact that people have the ability



Challenge 39 to talk about it! Moreover, the symmetry of nature is considerably higher than that of a forget-me-not. This large symmetry is at the basis of the famous expression $E_0 = mc^2$, as we will see.

Why can we think and talk?

Ref. 15

The hidden harmony is stronger than the apparent.
Heraclitos of Ephesos, about 500 B.C.

Why can we understand somebody when he is talking about the world, even though we are not in his shoes? We can for two reasons: because most things look *similar* from different viewpoints, and because most of us have already had similar experiences *beforehand*.

‘Similar’ means that what *we* observe and what *others* observe somehow correspond. Many aspects of observations do not depend on our viewpoint. For example, the number of petals of a flower has the same value for all observers. We can therefore say that this quantity has the highest possible symmetry. We will see below that mass is another such example. Observables with the highest possible symmetry are called *scalars* in physics. Other aspects change from observer to observer, such as apparent size variations with distance. However, the actual size is observer-independent. In general terms, any type of *viewpoint independence* is a form of symmetry, and the observation that two people looking at the same thing from different viewpoints can understand each other proves that nature is symmetric. The details of this symmetry will be explored in this section and during most of the rest of our hike.

Challenge 56

In the world around us, we note another general property: not only does the same phenomenon look similar to different observers, but *different* phenomena look similar to the *same* observer. For example, we know that if the fire in the kitchen burns the finger, it will do so outside the house as well, and also in other places and at other times. Nature shows *reproducibility*. Nature shows no surprises. In fact, our memory and our thinking are only possible because of this basic property of nature. (Can you confirm this?) As we will see, reproducibility leads to additional strong restrictions on the description of nature

Without viewpoint independence and reproducibility, talking to others or to oneself would be impossible. Even more importantly, we will discover that viewpoint independence and reproducibility do more than determining the possibility of talking to each other; they also fix the *content* of what we can say to each other. In other words, we will see in the following that the description of nature follows logically, almost without choice, from the simple fact that we can talk about nature to our friends!

Viewpoints

Tolerance ... is the suspicion that the other might be right.
Kurt Tucholski (1890–1935), German writer.

When a young human starts to meet other people in childhood, it quickly finds out that certain experiences are shared, while others, such as dreams, are not. Learning to make this distinction is one of the adventures of human life. In our adventure, we concentrate on a section of the first type of experiences, *physical* observations. However, even among these,



distinctions are to be made. In daily life we are used to assuming that weights, volumes, lengths, and time intervals are independent of the viewpoint of the observer. We can talk about these observed quantities to anybody, and there are no disagreements over their values, provided they have been measured correctly. However, other quantities do depend on the observer. Imagine talking to a friend after he jumped from one of the trees along our path, while he is still falling downwards. He will say that the forest floor is approaching with high speed, whereas the observer below will maintain that the floor is stationary. Obviously, the difference between the statements is due to their different viewpoints. The velocity of an object, in this example that of the forest floor or of the friend itself, is thus a less symmetric property than weight or size. Not all observers agree on its value.

In the case of viewpoint dependent observations, understanding is still possible with help of little effort: each observer can *imagine* observing from the point of view of the other, and *check* whether the imagined result agrees with the statement of the other. * If the thus-imagined statement and the actual statement of the other observer agree, the observations are consistent, and the difference in statements is due only to the different viewpoints; otherwise, the difference is fundamental, and they cannot talk to each other. Using this approach, you might even argue whether human feelings, judgments or taste lead to fundamental differences.

Challenge 73

The distinction between viewpoint-invariant and viewpoint-dependent quantities is essential. Invariant quantities such as mass or shape describe *intrinsic* properties, and quantities depending on the observer make up the *state* of the system. Therefore, we must answer the following questions in order to find a *complete* description of the state of physical systems:

- Which viewpoints are possible?
- How are descriptions transformed from one viewpoint to another?
- Which observables do these symmetries admit?
- What do these results tell us about motion?

In the discussion so far, we have studied viewpoints differing in location, in orientation, in time and, most importantly, in motion. With respect to each other, observers can be at rest, move with constant speed, or accelerate. These ‘concrete’ changes of viewpoint are those we will study first. In this case the requirement of consistency of observations made by different observers is called the *principle of relativity*. The symmetries associated with this type of invariance are also called *external* symmetries. They are listed in Table 20.

See page 137

A second class of fundamental changes of viewpoint concerns ‘abstract’ changes. Viewpoints can differ by the mathematical description used, and then are generally called *changes of gauge*. They will be introduced first in the section of electrodynamics. Again, it is required that all statements be consistent across different mathematical descriptions. This requirement of consistency is called the *principle of gauge invariance*. The associated symmetries are called *internal* symmetries.

The consistency requirements are called ‘principles’ because these basic statements are so strong that they almost completely determine the ‘laws’ of physics, as will be seen shortly.

Ref. 124 * Humans develop the ability to imagine that others can be in situations *different* from their own at the age of about four years. Therefore, before the age of four, humans are unable to understand special relativity; afterwards, they can.

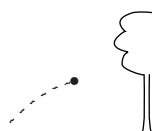

The third principle, whose importance is also not evident from everyday life, is the behaviour of a system under exchange of its parts. The associated invariance is called *permutation symmetry*. It is a *discrete* symmetry, and we will encounter it in the second part of our adventure.

Later on we will discover that looking for a complete description of the state of objects will also yield a complete description of their *intrinsic* properties. But enough of introduction; let us come to the heart of the topic.

Symmetries and groups

Since we are looking for a complete description of motion, we need to understand the symmetries of nature. A system which appears identical when observed from different viewpoints is said to be symmetric or to possess a *symmetry*. One also says that the system possesses an *invariance* under the specified changes from one viewpoint to the other, which are called *symmetry operations* or *transformations*. A symmetry is thus a set of transformations. But it is more than that: the concatenation of two elements, namely of two symmetry operations, is another symmetry operation. To be more precise, a symmetry is a set $G = \{a, b, c, \dots\}$ of elements, the transformations, together with a binary operation \circ called *concatenation* or *multiplication* and pronounced ‘after’ or ‘times’, in which the following properties hold for all elements a, b, c :

$$\begin{aligned} & \text{associativity, i.e.} && (a \circ b) \circ c = a \circ (b \circ c) \\ & \text{a neutral element } e \text{ exists such that} && e \circ a = a \circ e = a \\ & \text{an inverse element } a^{-1} \text{ exists such that} && a^{-1} \circ a = a \circ a^{-1} = e \end{aligned} \quad (58)$$

Any set which fulfils these defining properties or axioms is called a (*mathematical*) *group*. Historically, the notion of group was the first example of a mathematical structure which was defined in a completely abstract manner. Can you give an example of a group taken from daily life? Groups appear frequently in physics and mathematics, because symmetries are almost everywhere, as we will see.* Are you able to list the symmetry operations of Figure 65? **

Challenge 90
Challenge 107

Representations

Challenge 124

Observing a symmetric and composed system such as the one shown in Figure 65, we notice that each of its parts, for example each red patch, belongs to a set of similar objects, usually called a *multiplet*. Taken as a whole, the multiplet has (at least) the symmetry properties

* In principle, mathematical groups need not be symmetry groups; but one can prove that all groups can be seen as transformation groups on some suitably defined mathematical space, so that in mathematics one can use the terms ‘symmetry group’ and ‘group’ interchangeably.

A group is called *abelian* if the concatenation/multiplication is commutative, i.e. if $a \circ b = b \circ a$ for all couples of elements. In this case the multiplication is sometimes called *addition*. A subset $G_1 \subset G$ of a group G can itself be a group; one then calls it a *subgroup* and often says sloppily that G is *larger* than G_1 or that G is a *higher* symmetry group than G_1 .

** The most beautiful book on this topic is the text by BRANKO GRÜNBAUM & G.C. SHEPHARD, *Tilings and Patterns*, W.H. Freeman and Company, New York, 1987. It has been translated into several languages and republished several times.

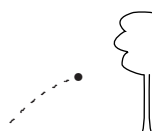

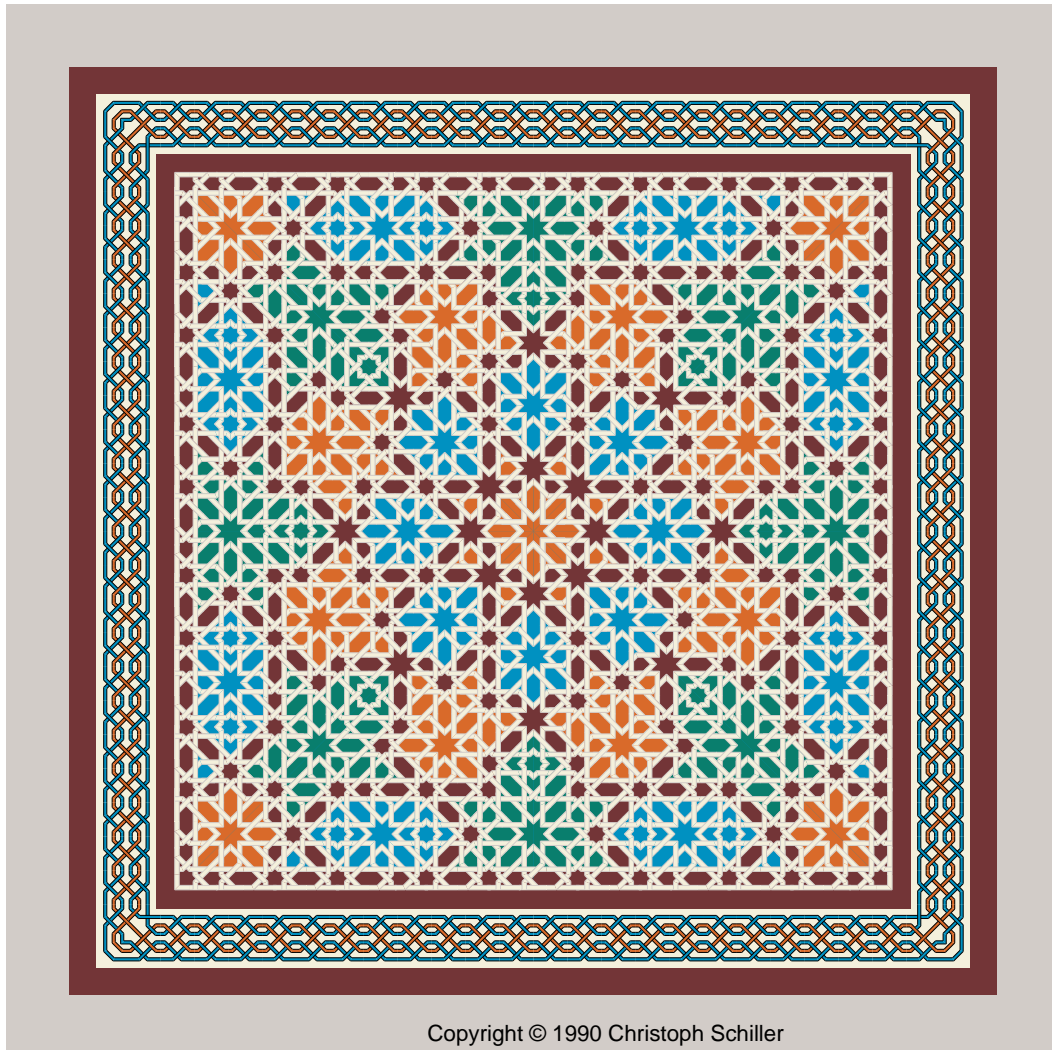

Figure 65 A Hispano-Arabic ornament from the Governor's Palace in Sevilla

of the whole system. For some coloured patches we need four objects to make up a full multiplet, whereas for others we need two or only one, such as in the case of the central star. In fact, in any symmetric system each part can be classified by saying to what type of multiplet it belongs. Throughout our mountain ascent we will perform the same classification with every part of nature, with ever-increasing precision.

A *multiplet* is a set of parts which transform into each other under all symmetry transformations. Mathematicians often call abstract multiplets *representations*. By specifying to which multiplet a component belongs, we describe in which way the component is part of the whole system. Let us see how this classification is achieved.

In mathematical language, symmetry transformations are usually described by matrices. For example, in the plane, a reflection along the first diagonal is represented by the matrix

Challenge 141

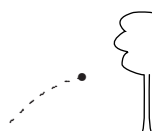

$$D(\text{refl}) = \begin{pmatrix} 0 & 1 \\ 1 & 0 \end{pmatrix} , \tag{59}$$

Challenge 158 since every point (x, y) becomes transformed to (y, x) when multiplied by the matrix $D(\text{refl})$. Therefore, for a mathematician a *representation* of a symmetry group G is an assignment of a matrix $D(a)$ to each group element a in such a way that the representation of the concatenation of two elements a and b is nothing else than the product of the representations of the elements

$$D(a \circ b) = D(a)D(b) . \tag{60}$$

For example, the matrix of equation (59), together with the corresponding matrices for all the other symmetry operations, have this property.*

For every symmetry group, the construction and classification of all possible representations is an important task. It corresponds to the classification of all possible multiplets a symmetric system can be made of. In this way, understanding the classification of all multiplets and parts which can appear in Figure 65 will teach us how to classify all possible parts of which an object or an example of motion can be composed of!

A representation is called *unitary* if all matrices D are unitary.** Almost all representations appearing in physics, with only a handful of exceptions, are unitary: this term is the most restrictive, since it specifies that the corresponding transformations are one-to-one and invertible, which means that one observer never sees more or less than another. Obviously, if an observer can talk to a second one, the second one can also talk to the first.

The final important property of a multiplet or representation concerns is structure. If it can be seen as composed of sub-multiplets, it is called *reducible*, else *irreducible*; the same for representations. The irreducible representations obviously cannot be decomposed any further. For example, the symmetry group of Figure 65, commonly called D_4 , has eight elements. It the general, faithful, unitary and irreducible matrix representation

Challenge 175

* There some obvious, but important side conditions for a representation: the matrices $D(a)$ must be invertible, or non-singular, and the identity operation of G must be mapped to the unit matrix. In even more compact language one says that a representation is a *homomorphism* from G into the group of non-singular or invertible matrices. A matrix D is invertible if its determinant $\det D$ is not zero.

In general, if there exists a mapping f from a group G to another G' such that

$$f(a \circ_G b) = f(a) \circ_{G'} f(b) , \tag{61}$$

the two groups are called *homomorphic*, and the mapping f an *homomorphism*. A mapping which is also one-to-one is called a *isomorphism*.

A representation is called *faithful*, *true* or *proper* if it is also an isomorphism.

In the same way as groups, more complex mathematical structures such as rings, fields and associative algebras may also be represented by suitable classes of matrices. A representation of the field of complex numbers is given in Appendix D.

** The *transpose* A^T of a matrix A is defined element-by-element by $(A^T)_{ik} = A_{ki}$. The *complex conjugate* A^* of a matrix A is defined by $(A^*)_{ik} = (A_{ik})^*$. The *adjoint* A^\dagger of a matrix A is defined by $A^\dagger = (A^T)^*$. A matrix is called *symmetric* if $A^T = A$, *orthogonal* if $A^T = A^{-1}$, *hermitean* or *self-adjoint* (the two are synonymous in all physical applications) if $A^\dagger = A$ (hermitean matrices have real eigenvalues), and *unitary* if $A^\dagger = A^{-1}$. Unitary matrices have eigenvalues of norm one; multiplication by a unitary matrix is a one-to-one mapping; therefore the time evolution of physical systems is always described by a unitary matrix. A *real* matrix obeys $A^* = A$, an *antisymmetric* or *skew-symmetric* matrix is defined by $A^T = -A$, an *anti-hermitean* by $A^\dagger = -A$ and an *anti-unitary* by $A^\dagger = -A^{-1}$. All the mappings described by these special types of matrices are one-to-one. A matrix is *singular*, i.e. not one-to-one, if $\det A = 0$.

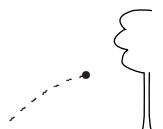

$$\begin{pmatrix} \cos n\pi/2 & -\sin n\pi/2 \\ \sin n\pi/2 & \cos n\pi/2 \end{pmatrix} \text{ for } n = 0..3, \begin{pmatrix} -1 & 0 \\ 0 & 1 \end{pmatrix}, \begin{pmatrix} 1 & 0 \\ 0 & -1 \end{pmatrix}, \begin{pmatrix} 0 & 1 \\ 1 & 0 \end{pmatrix}, \begin{pmatrix} 0 & -1 \\ -1 & 0 \end{pmatrix}. \quad (62)$$

The representation is an *octet*. The complete list of possible irreducible representations of the group D_4 is given by *singlets*, *doublets*, and *quartets*. Are you able to find them all? These representations allow the classification of all white and black ribbons that appear in the figure, as well as all coloured patches. The most symmetric elements are singlets, the least symmetric ones are members of the quartets. The complete system is always a singlet as well.

Challenge 192

Challenge 209

With these concepts we are ready to talk about motion with improved precision.

Table 19 Correspondences between the symmetries of an ornament, a flower and nature as a whole

Concept/system	Hispano-arabic pattern	Flower	Motion
Structure and components	set of ribbons and patches	set of petals, stem	motion path and observables
System symmetry	pattern symmetry	flower symmetry	symmetry of Lagrangian
Mathematical description of the symmetry group	D_4	C_5	in Galilean relativity: position, orientation, instant, and velocity changes
Invariants	number of multiplet elements	petal number	number of coordinates, magnitude of scalars, vectors and tensors
Representations of the components	multiplet types	multiplet types	tensors, including scalars and vectors
Most symmetric representation	singlet	part with circular symmetry	scalar
Simplest faithful representation	quartet	quintet	vector
Least symmetric representation	quartet	quintet	no limit (tensor of infinite rank)

Symmetries, motion and Galilean physics

Every day we experience that we are able to talk to each other about motion. It must therefore be possible to find an *invariant* quantity describing it. We already know it: it is the *action*. Indeed, the (Galilean) action is a number whose value is the same for each observer *at rest*, independent of his orientation or his observation time.

In the case of the arabic pattern of of Figure 65, the symmetry allowed to deduce the list of multiplets, or representations, that can be its building blocks. This approach must be possible for motion as well. We deduced the classification of the ribbons in the arabic pattern into singlets, doublets, etc. from the various possible observation viewpoints. For

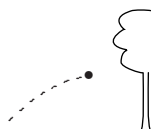

a moving system, the building blocks, corresponding to the ribbons, are the *observables*. Since we observe that nature is symmetric under many different changes of viewpoints, we can classify all possible observables. To do so, we need to take the list of all viewpoint transformations and deduce the list of all their representations.

Our everyday life shows that the world stays unchanged after changes in position, in orientation, and in observation time. These transformations are different from those of the arabic pattern in two respects: they are *continuous*, and they are *unbounded*. As a result, their representations will generally be concepts which can vary continuously and without bounds: they will be *quantities* or *magnitudes*. In other words, observables will be constructed with *numbers*. In this way we have deduced why numbers are *necessary* for any description of motion.*

Since observers can differ in orientation, most representations will be objects possessing a direction. To make a long story short, the change of observation position, orientation or instant leads to the result that all observables are either ‘scalars’, ‘vectors’ or higher-order ‘tensors.’**

A *scalar* is an observable quantity which stays the same for all observers: it corresponds to a singlet. Examples are the mass or the charge of an object, the distance between two points, the distance of the horizon, and many others. Their possible values are (usually) continuous and unbounded, and without direction. Other examples of scalars are the potential at a point and the temperature at a point. Velocity is obviously not a scalar, nor is the coordinate of a point. Can you find more examples and counterexamples?

Challenge 243

Energy is an interesting observable. It is a scalar if only changes of place, orientation, and time of observation are considered. Energy is not a scalar if changes of observer speed are included. Nobody tried to find a generalization of energy which is a scalar also for moving observers, until Albert Einstein discovered it. More about this issue shortly.

Any quantity which has a magnitude, a direction, and which ‘stays the same’ with respect to the environment when changing viewpoint is a *vector*. For example, the arrow between two fixed points on the floor is a vector. Its length is the same for all observers; its direction changes from observer to observer, but not with respect to its environment. On the other hand, the arrow between a tree and the place where a rainbow touches the earth is *not* a vector, since that place does not stay fixed with respect to the environment, when the observer changes.

Mathematicians say that vectors are directed entities staying invariant under coordinate transformations. Velocities of objects, accelerations, and field strength are examples of vectors. (Can you show that?) The magnitude of a vector is a scalar; it is the same for any observer. By the way, a famous and baffling result of 19th-century experiments is that the velocity of light is *not* a vector for Galilean transformations. This mystery will be solved shortly.

Challenge 243

Tensors are generalized vectors. As an example, take the moment of inertia of an object. It specifies the dependence of the angular momentum on the angular velocity. For any object, doubling the magnitude of angular velocity doubles the magnitude of angular momentum;

See page 68

* Only scalars, in contrast to vectors and higher order tensors, may also be quantities which only take a discrete set of values, such as +1 or -1 only. In short only scalars may be *discrete* observables.

** Later on, *spinors* will be added to this list, which will then be complete.

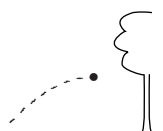

however, the two vectors are not parallel to each other if the object is not a sphere. If any two vector quantities are proportional like the two in the example, in the sense that doubling the magnitude of one vector doubles the magnitude of the other, but without the two vectors being parallel to each other, then the proportionality factor is a tensor. (Second order) *tensors* are thus quantities with a magnitude, a direction, and a *shape*.^{*} Can you name another example?

See page 81

Challenge 277

Let us get back to the description of motion. Table 19 shows that in physical systems we always have to distinguish between the symmetry of the whole Lagrangian – corresponding to the symmetry of the complete pattern – and the representation of the observables – corresponding (sloppily) to the symmetry of the ribbons. Since the action must be a scalar and since all observables must be tensors, Lagrangians contain sums and products of tensors only in combinations forming scalars. Lagrangians contain only scalar products or its generalizations. In short, Lagrangians always look like

$$L = \alpha a_i b^i + \beta c_{jk} d^{jk} + \gamma e_{lmn} f^{lmn} + \dots \quad (63)$$

where the indices always come in matching pairs to be summed over. (Therefore summation signs are usually simply left out.) The Greek letters represent constants. For example, the action of a free point particle in Galilean physics was given as

$$S = \int L dt = \frac{m}{2} \int v^2 dt \quad (64)$$

which is indeed of the form just mentioned. We will encounter many other cases during our study of motion.^{**}

Galileo already understood that motion is also invariant under change of viewpoints with different velocity. However, the action just given does not reflect this. It took another 250 years to find out the correct generalization: the theory of special relativity. Before studying it, we need to finish the present topic.

* Tensors (of rank 2) have magnitudes, directions, and connections between directions. Vectors are quantities with a magnitude and a direction; tensors are quantities with a magnitude and with a direction depending on a second, chosen direction. Tensors describe simple distributions in space. If vectors can be visualised as oriented arrows, tensors can be visualized as oriented ellipsoids.

A vector is described mathematically by a *list* of components; a tensor is described by a *matrix* of components. A vector has the same length and direction for every observer; a tensor (of rank 2) has the same determinant, the same trace, and the same sum of diagonal subdeterminants for all observers.

A n th-order tensor is the proportionality factor between a first order tensor, i.e. between a vector, and an $(n - 2)$ nd-order tensor. Tensors of higher orders correspond to more and more complex shapes. Vectors and scalars are first and zeroth order tensors. The order, by the way, also gives the number of indices an observable has. Can you show this?

Challenge 260

** By the way, is the usual list of possible observation viewpoints – namely different positions, different observation instants, different orientations, and different velocities – also *complete* for the action (64)? Surprisingly, the answer is no. One of the first who noted the fact was U. Niederer in 1972. Studying the quantum theory of point particles, he found that even the action of a Galilean free point particle is invariant under some additional transformations. If the two observers use as coordinates (t, \mathbf{x}) and (τ, ξ) , the action is invariant under the transformations

Ref. 125

Challenge 294

$$\xi = \frac{\mathbf{R}\mathbf{x} + \mathbf{x}_0 + \mathbf{v}t}{\gamma t + \delta} \quad \text{and} \quad \tau = \frac{\alpha t + \beta}{\gamma t + \delta} \quad \text{with} \quad \mathbf{R}^T \mathbf{R} = 1 \quad \text{and} \quad \alpha\delta - \beta\gamma = 1 \quad . \quad (65)$$

where \mathbf{R} describes the rotation from the orientation of one observer to the other, \mathbf{v} the velocity between the two observers, and \mathbf{x}_0 the vector between the two origins at time zero.

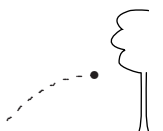

Reproducibility, conservation, and Noether’s theorem

I will leave my mass, charge and momentum to science.
Graffito

Challenge 311

It is now obvious that the reproducibility of observations, the symmetry under change of instant of time, is also a case of viewpoint independence. (Can you find its irreducible representations?) The connection has several important consequences. We have seen that symmetry implies invariance. It turns out that for *continuous* symmetries, such as time symmetry, this sentence can be made more precise: for any continuous symmetry of the Lagrangian there is an associated conserved constant of motion and vice versa. The exact formulation of this connection is the theorem of Emmy Noether. * She found the result in 1915 when helping Albert Einstein and David Hilbert, who were both struggling and competing at constructing general relativity. However, the result applies to any type of Lagrangian.

Ref. 126

Noether investigated continuous symmetries depending on a continuous parameter b . A viewpoint transformation is a symmetry if the action S does not depend on the value of b . For example, changing position as

$$x \mapsto x + b \tag{67}$$

leaves the action

$$S_o = \int T(v) - U(x)dt \tag{68}$$

invariant, as $S(b) = S_o$. This situation implies that

$$\frac{\partial T}{\partial v} = 2p = const \quad ; \tag{69}$$

in short, symmetry under change of position implies conservation of momentum. The converse is also true.

Challenge 328

In case of symmetry under change of observation time, we find

$$T + U = const \quad ; \tag{70}$$

time invariance implies constant energy. Again, the converse is also correct. One also says that energy and momentum are the *generators* of time and space translations.

The important special cases of these transformations are

$$\begin{aligned} &\text{The connected, static Galilei group } \xi = \mathbf{R}\mathbf{x} + \mathbf{x}_o + \mathbf{v}t \quad \text{and} \quad \tau = t \\ &\text{The transformation group } SL(2,\mathbf{R}) \quad \xi = \frac{\mathbf{x}}{\gamma t + \delta} \quad \text{and} \quad \tau = \frac{\alpha t + \beta}{\gamma t + \delta} \end{aligned} \tag{66}$$

The latter, three-parameter group includes *spatial inversion*, *dilations*, *time translation*, and a set of time-dependent transformations such as $\xi = \mathbf{x}/t$, $\tau = 1/t$ called *expansions*. Dilations and expansions are rarely mentioned, as they are symmetries of point particles only, and do not apply to everyday objects and systems. They will return to be of importance later on.

* Emmy Noether (Erlangen, 1882–Bryn Mayr, 1935), German mathematician. The theorem is only a sideline in her career which she dedicated mostly to number theory. The theorem also applies to gauge symmetries, where it states that to every gauge symmetry corresponds an identity of the equation of motion, and vice versa.

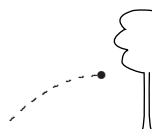

The conserved quantity for a continuous symmetry is sometimes called the *Noether charge*, because the term *charge* is used in theoretical physics to designate conserved extensive observables. In other words, energy and momentum are Noether charges. ‘Electric charge’, ‘gravitational charge’ (i.e. mass), and ‘topological charge’ are other common examples. What is the conserved charge for rotation invariance?

Challenge 345

We note that the expression ‘energy is conserved’ has several meanings. First of all, it means that the energy of a *single* free particle is constant in time. Secondly, it means that the total energy of any number of independent particles is constant. Finally, it means that the energy of a *system* of particles, i.e. including their interactions, is constant in time. Collisions are examples of the latter case. Noether’s theorem makes all of these points at the same time, as you can verify using the corresponding Lagrangians.

Challenge 362

But Noether’s theorem also makes, or better repeats, an even stronger statement: if energy were not conserved, time could not be defined. The whole description of nature requires the existence of conserved quantities, as we noticed when we introduced the concepts of object, state, and environment. For example, we defined objects as *permanent* entities, that is, as entities characterized by conserved quantities. We also saw that the introduction of time is possible only because in nature there are no surprises. Noether’s theorem describes exactly what such a surprise would have to be: the non-conservation of energy. It has never been observed.*

See page 34

See page 108

Since symmetries are so important for the description of nature, Table 20 gives an overview of all the symmetries of nature we will encounter. Their main properties are also listed. Except for those marked as ‘approximate’ or ‘speculative’, an experimental proof of incorrectness of any of them would be a big surprise indeed.

Table 20 The symmetries of relativity and quantum theory with their properties; at the same time, the complete list of logical *inductions* used in the two fields

Symmetry	type [param. number]	space of action	group topology	possible representa- tions	conserved quantity	vacuum/ matter is symmetric	main effect
Geometric or space-time, external, symmetries							
Time and space translation	$R \times R^3$ [4 par.]	space, time	not compact	scalars, vectors,	momentum and energy	yes/yes	allow everyday
Rotation	SO(3) [3 par.]	space	S^2	tensors	angular momentum	yes/yes	communica- tion
Galilei boost	R^3 [3 par.]	space, time	not compact	same	centre of mass velocity	approx- imately; at low speeds	
Lorentz	homog. Lie SO(3,1) [6 par.]	space- time	not compact	tensors, spinors	energy- momentum $T^{\mu\nu}$	yes/yes	constant light speed

* Quantum theory adds some details here, as we will find out whne studying it.

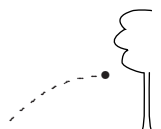

Symmetry	type [param. number]	space of action	group topology	possible representa- tions	conserved quantity	vacuum/ matter is symmetric	main effect
Poincaré ISL(2,C)	inhomog. Lie [10 par.]	space- time	not compact	tensors, spinors		yes/yes	
Dilation invariance	R^+ [1 par.]	space- time			none	yes/no	massless particles
Special conformal invariance	R^4 [4 par.]	space- time			none	yes/no	
Conformal invariance	[15 par.]	space- time				yes/no	

Dynamic, interaction-dependent symmetries: gravity

$1/r^2$ gravity	SO(4) [6 par.]	config. space			perihelion direction	yes/yes	
Diffeomorphism invariance	$[\infty$ par.]	space- time			locally vanishing energy- momentum divergence	yes/no	perihelion shift

Dynamic, classical and quantum mechanical motion symmetries

Motion('time') inversion T		Hilbert or phase space	discrete	even, odd	T-parity	yes/no	
Parity('spatial') inversion P		Hilbert or phase space	discrete	even, odd	P-parity	yes/no	
Charge conjugation C	global, antilinear, anti- hermitean	Hilbert or phase space	discrete	even, odd	C-parity	yes/no	
CPT		Hilbert or phase space	discrete	even	CPT-parity	yes/yes	makes field theory possible
Chiral symmetry		Hilbert space	discrete			approxi- mately	'massless' fermions ^a

Dynamic, interaction-dependent, gauge symmetries

Electromagnetic classical gauge inv.	$[\infty$ par]	yes/yes	...
--	----------------	-----	-----	-----	-----	---------	-----

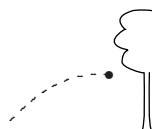

Symmetry	type [param. number]	space of action	group topology	possible representa- tions	conserved quantity	vacuum/ matter is symmetric	main effect
Electromagnetic q.m. gauge inv.	abelian Lie U(1) [1 par.]	Hilbert space	circle S^1		electric charge	yes/yes	massless photon
Electromagnetic duality	abelian Lie U(1) [1 par.]		circle S^1			yes/no	
Weak gauge	non-abelian Lie SU(2) [3 par.]	Hilbert space			weak charge	no/ approx.	
Colour gauge	non-abelian Lie SU(3) [8 par.]	Hilbert space			colour	yes/yes	massless gluons
Permutation symmetries							
Particle exchange	discrete	Fock space and simil.	discrete	fermions and bosons	none	n.a./yes	Gibbs' paradox
Selected speculative symmetries of nature							
GUT	E8, SO(10)	Hilbert	yes/no	coupling constant convergence
N-super- symmetry ^b	global	Hilbert		particles, sparticles	T_{mn} and N spinors ^c Q_{imn}	no/no	'massless' ^a particles
R-parity	discrete	Hilbert				yes/yes	
Braid symmetry						yes/?	
Space-time duality	discrete	all				yes/?	fixes particle masses
Event symmetry		space- time				yes/no	

For details about the connection between symmetry and induction, see page 452. The explanation of the terms in the table will be completed in the rest of the walk.

a. Only approximate; 'massless' means that $m \ll m_{\text{Pl}}$, i.e. that $m \ll 22 \mu\text{g}$.

b. $N = 1$ supersymmetry, but not $N = 1$ supergravity, is probably a good approximation for nature at everyday energies.

c. $i = 1 \dots N$.

In summary, since we can *talk* about nature we can deduce several of its symmetries, in particular its symmetry under time and space translations. From nature's symmetries,

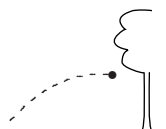

using Noether's theorem, we can deduce the conserved charges, such as energy or linear and angular momentum. In other words, the definition of mass, space, and time, together with their symmetry properties, is *equivalent* to the conservation of energy and momentum. Conservation and symmetry are two ways to express the same property of nature. To put it simply, our ability to talk about nature means that energy and momentum are conserved.

In general, to uncover the 'laws' of nature, the most elegant way is to search for nature's symmetries. Historically, once this connection had been understood, physics made rapid progress. For example, Albert Einstein discovered the theory of relativity in this way, and Paul Dirac started off quantum electrodynamics. We will use the same method throughout our walk; in its third part we will uncover some symmetries which are even more mind-boggling than those of relativity. For the time being, we continue with the next method allowing a global description of motion.

Simple motions of extended bodies – Oscillations and waves

We defined action as the integral of the lagrangian, and the lagrangian as the difference between kinetic and potential energy. For example, the Lagrangian of a mass attached to a spring is given by $L = mv^2/2 - kx$. Can you confirm it?

Challenge 379

The lagrangian has a beautiful property: it describes the oscillation of the spring length. The motion is exactly the same as that of a long pendulum. It is called harmonic motion, because an object vibrating fast enough in this way produces a pure musical sound. The graph of a harmonic oscillation is called a *sine curve*; it can be seen as the basic building block of all oscillations. All other, non-harmonic oscillations in nature can be composed from it.

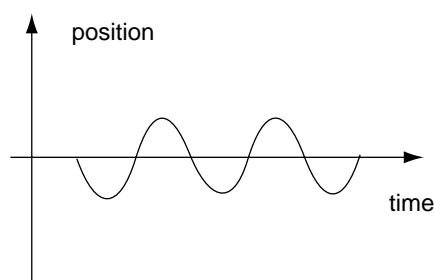

Figure 66 The simplest oscillation

– CS – a section about waves and other topics will be added here – CS –

Fun challenges about waves and extended bodies

One never knows enough about waves.

Challenge 396

- Is a standing wave a wave?

Challenge 413

- Why are there many small holes in the ceilings of many office buildings?
- Every year, the Institute of Maritime Systems of the University of Rostock organizes a contest. The challenge is to build a paper boat with the highest possible carrying capacity. The paper boat must weigh at most 10 g; the carrying capacity is measured by pouring lead small shot onto it, until the boat sinks. The 2002 record stands at 2.6 kg. Are you able to reach this value? (For more information, see the www.paperboat.de web site.)

Challenge 430

Ref. 1

- Yakov Perelman lists the following problems in his delightful physics problem book. A stone falling into a lake produces circular waves. What is the shape of waves produced by a

Challenge 447

- stone falling into a river?

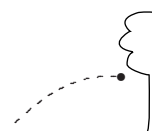

▪ A modern version of an old quiz, posed by Daniel Colladon (1802–1893). A ship of mass m in a river is pulled through ropes by horses walking along the river. If the river is of superfluid helium, meaning that there is no friction between ship and river, what energy is necessary to pull the ship along the river until a height h has been overcome?

Challenge 464

▪ It is possible to build a lens for sound, in the same way as it is possible to build lenses for light. How would such a lens look like?

Challenge 481

▪ What is the sound heard inside a shell?

Challenge 498

▪ Light takes about eight minutes to arrive from the sun to the earth. What consequence does this have for a sunrise?

Challenge 515

▪ Can you describe how a Rubik's cubes is built? And its generalizations to higher numbers of segments? Is there a limit to the number of segments? These puzzles are tougher than the search for a rearrangement. Similar puzzles can be found in many mechanisms, from robots to textile machines.

Challenge 532

▪ Usual sound produces a pressure variation of 10^{-8} bar on the ear. How is this determined?

Challenge 549

Do extended bodies exist?

We just studied the motion of extended bodies. Strangely enough, the question of their existence has been one of the most intensely discussed questions in physics. Over the centuries, it appeared again and again, at each improvement of the description of motion; the answer alternated between the affirmative and the negative. Many thinkers have been persecuted and many still are being persecuted by giving answers not politically correct! In fact, the issue already appears in everyday life.

Mountains, manifolds and fractals

Whenever we climb a mountain, we follow its outline. We usually describe this outline by a curved two-dimensional surface. In everyday life we find that this is a good approximation. But there are alternatives. The most popular is the idea that mountains are fractal surfaces. A *fractal* was defined by Benoit Mandelbrodt as a set which is self-similar under a countable but infinite number of magnification values. We encountered fractal lines earlier on. An example of an algorithm building a (random) fractal *surface* is shown on the left side of Figure 67. It produces shapes which look incredibly similar to real mountains. The results are so realistic that they are used in Hollywood movies. If this description would be correct, mountains would be extended, but not continuous.

See page 47

Ref. 127

But mountains could also be fractals of a different sort, as shown in the right side of Figure 67. Floors could have an infinity of small and smaller holes. Can you devise an experiment to decide whether fractals or manifolds provide the correct description for mountain surfaces?

Challenge 566

In fact, one could imagine that mountains have to be described by three dimensional versions of the right side of the figure. Mountains would then be some sort of mathematical swiss cheese. To settle the issue, a chocolate bar can help.

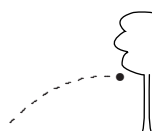

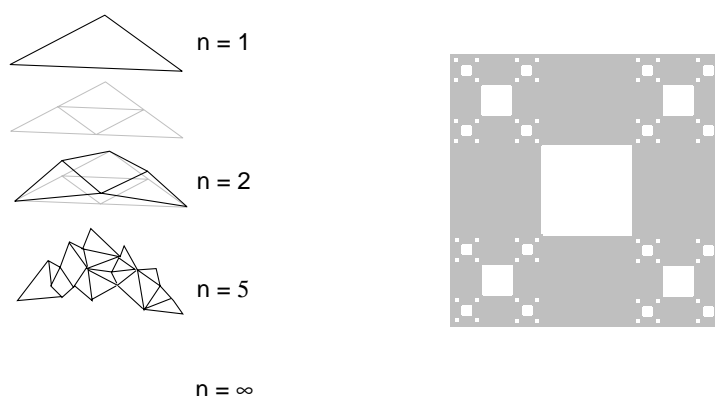

Figure 67 Floors and mountains as fractals

Can a chocolate bar last forever?

From a drop of water a logician could predict an Atlantic or a Niagara.
Arthur Conan Doyle (1859–1930), *A Study in Scarlet*.

Any child knows how to make a chocolate bar last forever, namely by eating every day only half the remainder. However, this method only works if matter is scale-invariant. The method only works if matter is either *fractal*, as it then would be scale invariant for a discrete set of zoom factors, or *continuous*, in which case it would be scale invariant for any zoom factor. What case applies to nature?

See page 47

We have already encountered a fact making continuity a questionable assumption: continuity would allow us, as Banach and Tarski showed, to multiply food and any other matter by smart cutting and reassembling. Continuity would allow children to eat the *same* amount of chocolate every day, without ever buying a new bar. However, fractal chocolate is not ruled out in this way; an experiment can settle the question. Let us take fluid chocolate; or even simpler, let us take some oil – which is the main ingredient of chocolate anyway – and spread it out over an ever increasing surface. For example, one can spread a drop of oil onto a pond on a day without rain or wind; it is not difficult to observe which parts of the water are covered by the oil and which are not. Interestingly, a small droplet of oil cannot cover a surface larger than about – can you guess the value? Trying to spread the film further inevitably rips it apart. The chocolate method thus does not work for ever; it comes to a sudden end. The oil experiment, first popularized by Kelvin, shows that there is a *minimum* thickness of oil films, with a value of about 2 nm.* This simple measurement can be conducted also in high school and shows that there is a smallest size in matter. The general conclusion is not a surprise, however. The existence of a smallest size – not its value – was already deduced by Galileo, when he studied some other, simple questions.**

Challenge 583

* It is often claimed that Benjamin Franklin first conducted the experiment; that is wrong. Franklin did not measure the thickness and did not even think about minimal thickness; he poured oil on water, but missed the most important conclusion, which was taken only a century later by Kelvin.

** Galileo was brought to trial because of his ideas on atoms, not on the motion of the earth, as is often claimed. To get a clear view of the matters of dispute in the case of Galileo, especially of interest to physicists, the best text is the excellent book by PIETRO REDONDI, *Galileo eretico*, Einaudi, 1983, translated into English as

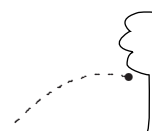

How high can animals jump?

Fleas can jump to heights a hundred times their size, humans only to heights about their own size. In fact, biological studies yield a simple observation: all animals, independently of their size, achieve the same jumping height of 1.5 ± 0.7 m, whether they are humans, cats, grasshoppers, apes, horses, leopards, etc. Explaining this constancy takes only two lines. Are you able to do it?

Ref. 128

Challenge 600

The observation seems to be an example of scale invariance. But there are some interesting exceptions at both ends of the mass range. On the small side, mites and other small insects do not achieve such heights because, like all small objects, they encounter the problem of air resistance. At the large end, elephants do not jump that high, because doing so would break their bones. But why do bones break at all?

Why are all humans of about the same size? Why are there no giant adults with a height of ten metres? Why aren't there any land animals larger than elephants? The answer yields the key to understanding the structure of matter. In fact, the materials of which we are made would not allow such change of scale, as the bones of giants would collapse under the weight they have to sustain. Bones have a finite strength because their constituents stick to each other with a finite attraction. Continuous matter could not break at all, and fractal matter would be infinitely fragile. Matter only breaks under finite loads because it is composed of smallest constituents.

Felling trees

The lower, gentle slopes of motion mountain are covered by trees. Trees are fascinating structures. Take their size. Why do trees have limited size? Already in the 16th century, Galileo knew that increasing tree height is not possible without limits: at some point a tree would not have the strength to support its own weight. He estimated the maximum height to be around 90 m; the actual record, unknown to him at the time, is 152 m. But why does a limit exist at all? The answer is the same as for bones: wood has a finite strength because

Galileo heretic, Princeton University Press, 1987. It is available also in many other languages. Redondi, a renowned historical scholar and colleague of Pierre Costabel, tells the story of the dispute between Galileo and the reactionary parts of the catholic church. He recently discovered a document of that time – the anonymous denunciation which started the trial – allowing him to show that the condemnation of Galileo to life imprisonment due to his views on the earth's motion was organized by his friend the pope to *protect* him from a sure condemnation to death about a different issue.

The reason for his arrest, as shown by the denunciation, were not his ideas on astronomy and on motion of the earth, as usually maintained, but his statements on matter. Galileo defended the view that since matter is not scale invariant, it is made of 'atoms' or, as he called them, 'piccolissimi quanti' – smallest quanta – which was and still is a heresy. A true catholic still is not allowed to believe in atoms. Indeed, atoms are not compatible with the change of bread and wine into human flesh and blood, called *transsubstantiation*, which is a central belief of the catholic faith. In Galileo's days, church tribunals punished heresy, i.e. deviating personal opinions, by the death sentence. Despite being condemned to prison in his trial, Galileo published his last book, written as an old man under house arrest, on the scaling issue. Today, the remainders of the catholic church continue to refuse to publish the proceedings and other documents of the trial. In addition, these remainders most carefully avoid the issue of atoms, as any catholic statement on the issue would start the biggest wave of humour on the planet. In fact, 'quantum' theory, named after the term used by Galileo, has become the most precise description of nature ever.

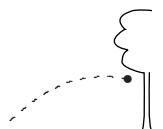

it is not scale invariant; and it is not scale invariant because it is made of small constituents, the atoms.

Challenge 617

In fact, the origin for the precise value of the limit is more involved. Trees must not break under strong winds. Wind resistance limits the height-to-thickness ratio h/d to about 50 for standard-sized trees (for $0.2\text{ m} < d < 2\text{ m}$). Are you able to deduce this limit? Thinner trees are limited in height to less than 10 m by the requirement that they return to the vertical after being bent by the wind.

Ref. 129

Such studies of natural constraints also answer the question of why trees are made from wood and not, for example, steel. Wood is actually the best material for making a light and stiff column. Only recently a few selected engineering composites managed to achieve slightly better performance.

Ref. 130

Why do materials break at all? All collected data yield the same answer and confirm Galileo's reasoning: because there is a smallest size in materials. For example, bodies under stress are torn apart at the position at which their strength is minimal. If a body were completely homogeneous, it could not be torn apart; a crack could not start anywhere. If a body had a fractal swiss cheese structure, cracks would have places to start, but they would need only an infinitesimal effort for their propagation.

Experimental confirmation is not difficult. It is sufficient to break a thin single crystal, such as a gallium arsenide wafer, in two. The breaking surface is either completely flat or shows extremely small steps, as shown in Figure 68. These steps are visible in a normal light microscope. It turns out that all observed step heights are multiples of a smallest height; its value is about 1 nm. The smallest height, the height of an atom, contradicts all possibilities of scale invariance. Matter is not scale invariant.

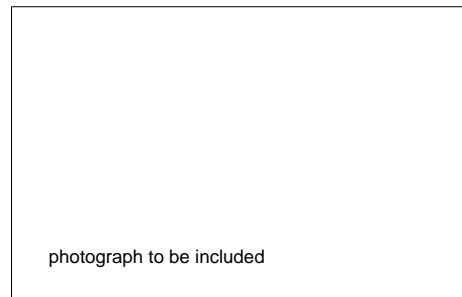

Figure 68 Atomic steps in broken gallium arsenide crystals seen under a conventional light microscope

Listening to silence

Climbing the slopes of Motion Mountain, we arrive in a region of the forest covered with deep snow. We stop one minute and look around. It is dark, all the animals are asleep, there is no wind, and there are no sources of sound. We stand still, without breathing, and listen to the silence. (You can have this experience also in a sound studio such as those used for musical recordings, or in a quiet bedroom at night, or putting wax in your ears.) In situations of complete silence, the ear automatically increases its sensitivity; * we then have a strange experience. We hear two noises, a lower and a higher pitched one, which obviously are generated inside the ear. Experiments show that the lower note is due to pulsating blood streaming through the head, and the higher note is due to the activity of the nerve cells in the inner ear.

This and many similar experiments confirm that whatever we do, we can never eliminate noise from measurements. This unavoidable type of noise is called *shot noise* in physics.

* The ear can measure pressure variations of at least as small as $20\ \mu\text{Pa}$.

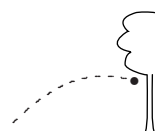

Measuring the properties of this type of noise, we find that they correspond precisely to what is expected if flows, instead of being motion of continuous matter, are transports of a large number of equal, small, and discrete entities. Indeed, simply listening to noise proves that electric current is made of electrons, that air and liquids are made of molecules, and that light is made of photons. In a sense, the sound of silence is the sound of atoms. Noise would not exist in continuous systems.

Little hard balls

I prefer knowing the cause of a single thing to being king of Persia.
Democritus

All these and many other observations show that matter is neither continuous nor a fractal; matter is made of smallest particles. Galileo, strengthened by the arguments on giants and trees, called them ‘smallest quanta.’ Today they are called ‘atoms’, in honour of a famous speculation of the ancient Greeks.

2500 years ago, this group of people asked the following question. If motion and matter are conserved, how can change and transformation exist? The philosophical school of Leucippus and Democritus of Abdera* deduced that there is only one possible solution: nature is made of void and of small, hard, indivisible, and conserved particles.** In this way any example of observed motion, change or transformation is due to rearrangements of these particles; change and conservation are reconciled.

In short, matter, being hard, having a shape, and being indivisible, were imagined as being made of atoms. Atoms are particles which are hard, have a shape, but are indivisible. In other words, the Greek imagined nature as a big Lego set. Legos are first of all hard or *impenetrable*, i.e. repulsive at very small distances. Legos are *attractive* at small distance; they remain stuck together. Finally, Legos have *no interaction* at large distances. Atoms behave in the same way. (Actually, what the Greek called ‘atoms’ partly corresponds to what today we call ‘molecules’, a term invented and introduced by Amadeo Avogadro in 1811. But let us forget this detailed nitty-gritty for the moment.)

Since atoms are so small, the experiments showing their existence took many years to convince everybody. In the nineteenth century, the idea of atoms was beautifully verified by the discovery of the ‘laws’ of chemistry. Then the noise effects were discovered. But nowadays, with the advances of technology, things are easier. Single atoms can be seen, photographed, hologrammed, counted, touched, moved, lifted, levitated, and thrown around. And indeed, like everyday matter, atoms have mass, size, shape, and colour. Single atoms have even been used as light sources.

Ref. 131, 132

Ref. 133

* Leucippus of Elea (Leucippos) (ca. 490–ca. 430 BCE), Greek philosopher; Elea is (probably) the island of his birth. Democritus (Demokritos) of Abdera (ca. 460–ca. 356 or 370 BCE), Greek philosopher. Arguably, Democritus was the greatest philosopher who ever lived. Together with his teacher Leucippus, he was the founder of the atomic theory; Democritus was a much admired thinker, contemporary of Socrates. The vain Plato never even mentions him, as Democritus was a danger to his own fame. Democritus wrote many books which have been lost, as they were not copied during the middle ages due to his too scientific and world view, which was felt as a danger by religious people.

** Especially if we imagine particles as little balls, we cannot avoid calling this a typically male idea.

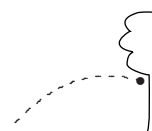

Several fields of modern physical research have fun playing with atoms in the same way that children do with Legos. Maybe the most beautiful example for these possibilities is provided by the many applications of the atomic force microscope. If you ever have the opportunity to see one, do not miss the occasion! * It is a simple device which follows the surface of an object with an atomically sharp needle; such needles, usually of tungsten, are easily fabricated with a simple etching

Ref. 134

method. The height changes of the needle along its path over the surface are recorded with the help of a deflected light ray. With a little care, the atoms of the object can be felt and made visible on a computer screen. With special types of such microscopes, the needle can be used to move atoms one by one to specified places on the surface. People can also scan a surface, pick up a given atom, and throw it towards a mass spectrometer to determine what sort of atom it is.

Ref. 135

Ref. 136

As an aside, the construction of atomic force microscopes is only a small improvement on what nature is building already by the millions; when we use our ears to listen, we are actually detecting changes in eardrum position of about 1 nm. In other words, we all have two ‘atomic force microscopes’ built into our heads.

In summary, matter is not scale invariant: in particular, it is neither smooth nor a fractal. Matter is made of atoms. Different types of atoms, as well as their various combinations, produce different types of substances. Pictures from atomic force microscopes show that size and arrangement of its atoms produce the *shape* and the *extension* of objects, confirming the lego model of matter. ** As a result, the description of motion of extended objects can be reduced to the description of the motion of their atoms. Atomic motion will be a major theme in the following. One of its consequences is especially important: heat.

* A cheap version costs only a few thousand Euro, and will allow you to study the difference between consecrated and non-consecrated wafers.

** Studying matter in even more detail yields the now well-known picture that matter, at higher and higher magnifications, is made of molecules, atoms, nuclei, protons and neutrons, and finally, quarks. Atoms also contain electrons. A final type of matter, neutrinos, is observed coming from the sun and from certain types of radioactive materials. Even though the fundamental bricks have become smaller with time, the basic idea remains: matter is made of smallest entities, nowadays called elementary particles. The second part of our mountain ascent uncovers this connection in detail. Appendix C lists the measured properties of all elementary particles.

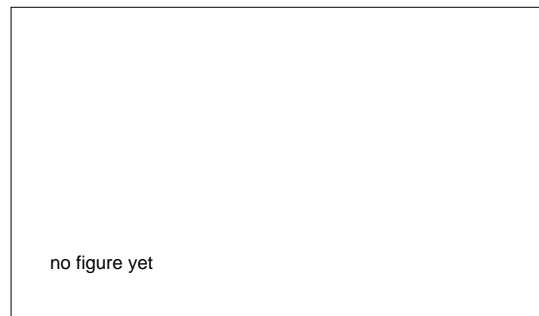

Figure 69 The principle and the realization of an atomic force microscope

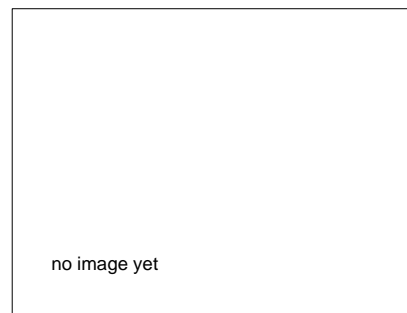
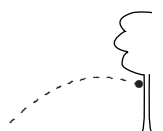

Figure 70 The surface of a silicon crystal mapped with an atomic force microscope



Challenges about fluids and other extended bodies

Before we continue, a few puzzles are due.

- When hydrogen and oxygen are combine to form water, the amount of hydrogen needed is exactly twice the amount of oxygen, if no gas is to be left over after the reaction. How does this confirm the existence of atoms? Challenge 634
- The most important component of air is nitrogen (about 70%). The second most important component is oxygen (about 20%). What is the third most common? Challenge 651
- A light bulb is placed, under water, in a stable steel cylinder with a diameter of 16 cm. A Fiat Cinquecento (500 kg) is placed on a piston pushing onto the water surface. Will the bulb resist? Challenge 668
- Which is most dense gas? The most dense vapour? Challenge 685
- The Swiss professor Auguste Piccard (1884–1962) was a famous explorer of the stratosphere. He reached the height of 16 km in his *aerostat*. Inside the airtight cabin hanging under his balloon, he had normal air pressure. However, he needed to introduce several ropes attached at the balloon into the cabin, in order to be able to pull them, as they controlled his balloon. How did he get the ropes into the cabin while avoiding that the air leaves the cabin? Challenge 702
- A human cannot breathe under water, even if he has a tube going to the surface. At a few metres of depth, trying to do so is inevitably fatal. Even at a depth of 60 cm, the human body only allows breathing that way for a few minutes. Why? Challenge 736
- A human in air falls with a speed of about 180 km/h, depending on its clothing. How long does a fall take from 3000 m to 200 m? Challenge 753
- Liquid pressure depends on height; for example, if the average human blood pressure at the height of the heart is 13.3 kPa, can you guess what it is inside the feet when standing? Challenge 770
- What is the maximum length a vertically hanging wire can have? Challenge 787
- The best giant soap bubbles can be made by mixing 1.5 l of water, 200 ml of corn syrup and 450 ml of dish cleaning liquid. Mix everything and then let it rest for four hours. You can then make the largest bubbles by dipping a metal ring of up to 100 mm diameter into the mixture.

Why are objects warm?

We continue our short stroll through the field of global descriptions of motion with an overview of heat and its main concepts. For our adventure we only need to know a bit about heat. The main points that are taught in high school are almost sufficient: Ref. 138

Macroscopic bodies, i.e. bodies made of many atoms, are described by temperature. Temperature is an aspect of the state of each body. Bodies in contact tend to the same temperature. In other words, temperature describes an equilibrium situation. This is often called the *zeroth principle of thermodynamics*.

Heat flows from one body to another, and accumulates. It has no measurable mass.* The content of heat inside a body increases with increasing temperature. The precise relation will be given shortly.

* This might change in future, when mass measurements improve in precision, thus allowing the detection of relativistic effects.

See page 193

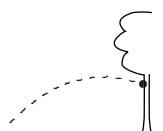

Observation	Temperature
Lowest, but unachievable temperature	0 K
In lasers, sometimes talking about negative temperature makes sense	
Temperature a perfect vacuum would have at earth's surface See page 592	40 zK
Lithium gas in certain laboratories – lowest value achieved by man, and possibly the coldest matter system in the universe	ca. 1 nK
Temperature of neutrino background in the universe	ca. 2 K
Temperature of photon gas background (or background radiation) in the universe	2.7 K
Liquid helium	4.2 K
Oxygen triple point	54.3584 K
Liquid nitrogen	77 K
Coldest weather measured (antarctic)	185 K = -88 °C
Average temperature of the earth's surface	287.2 K
Interior of human body	305.3 K
Hottest weather measured	331 K = 58 °C
Boiling point of water at standard pressure	373.13 K or 99.975 °C
Liquid iron	1 kK
Gold freezing point	1337.33 K
	2.9 kK
Light bulb filament	
Sun's surface	5.8 kK
Space between earth and moon (no typo)	up to 1 MK
Sun's centre	20 MK
Inside the JET fusion tokamak	100 MK
Centre of hottest stars	1 GK
Universe when it was 1 s old	100 GK
Heavy ion collisions – highest man-made value	up to 3.6 TK
Planck temperature – nature's upper temperature limit	10^{32} K

Table 21 Some temperature measurements

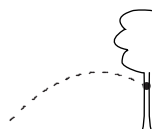

Heating implies flow of energy. Also friction heats up and slows down the moving bodies. In the old days, this ‘creation’ was even tested experimentally. It was shown that heat could be generated from friction, just by continuing rubbing, without any limit; this ‘creation’ implies that heat is not a material fluid extracted from the body – which in this case would be consumed after a certain time – but something else. Indeed, today we know that heat, even though it behaves like a fluid, is the disordered motion of particles.

To heat 1 kg of water by one degree, 4.2 kJ of mechanical energy need to be transformed through friction. The first to measure this with precision was, in 1842, the German physician Julius Robert Mayer (1814–1878). He performed this experiment as proof of the conservation of energy; indeed, he was the first to state energy conservation! It is one of the dark sides of modern physics that a medical doctor was the first to show the conservation of energy, and that furthermore, he was ridiculed by most physicists of his time. Worse, conservation of energy was accepted only when it was repeated many years later by two authorities: Hermann von Helmholtz (1821, Potsdam–1894) – himself also a physician turned physicist – and William Thomson (1824–1907) (later Lord Kelvin), who cited similar, but latter experiments by the English physicist James Prescott Joule (1818–1889).^{*} All of them acknowledged Mayer’s priority. Publicity by William Thomson eventually led to the naming of the unit of work after Joule.

In short, the sum of mechanical energy and of thermal energy is constant. This is usually called the *first principle of thermodynamics*. Equivalently, it is impossible to produce mechanical energy without paying with some other energy. This is an important statement, because among others it means that humanity will stop living one day. Indeed, we live mostly on energy from the sun; since the sun is of finite size, its energy content will be consumed one day. Can you estimate when this will happen?

Challenge 804

There is also a second and a third principle of thermodynamics, to be mentioned later on. In fact, the study of these topics is called *thermostatistics* if systems are at equilibrium, and *thermodynamics* if systems are away from equilibrium. In the latter case we distinguish situations *near* equilibrium, when equilibrium concepts such as temperature can still be used, from situations *far* from equilibrium, such as self-organization, where such concepts usually cannot be applied.

Brownian motion

For many years, scientist had observed that small particles in a liquid never come to rest, when observed in a microscope. They keep executing a random zigzag movement. In 1827, the English botanist Robert Brown (1773–1858) then showed with a series of experiments that this observation is independent of the type of particle and of the type of liquid. In other words, Brown had discovered a fundamental noise in nature. Only in 1905 and 1906, Albert Einstein and independently, Marian von Smoluchowski, argued that this effect is due to the molecules of the liquid colliding with the pollen. He proposed an experiment to check this, even though at that time nobody was able to observe atoms directly. As expected, the experiment makes use of the properties of the noise.

Ref. 139

It had already been clear for a long time that if smallest matter particles existed, heat had to be disordered motion of these constituents, and temperature had to be the average energy

^{*} Joule is pronounced such that it rhymes with ‘cool’, as his descendants like to stress.



Challenge 821 per degree of freedom of the constituents. * Figure 72 shows that for monoatomic gases

$$T_{\text{kin}} = \frac{3}{2}kT \tag{71}$$

where T_{kin} is the kinetic energy per particle, and T is temperature. The so-called *Boltzmann constant* $k = 1.4 \cdot 10^{-23} \text{ J/K}$ is the standard conversion factor between temperature and energy. ** At a room temperature of 298 K, the kinetic energy is thus 6 zJ.

Challenge 838 Using relation (71) to calculate the speed of air molecules at room temperature gives values of several hundred metres per second. Why then does smoke from a candle take so long to diffuse through a room? Rudolph Clausius (1822–1888) answered this question in the mid-19th century: diffusion is slowed by collisions with air molecules, in the same way that pollen particles are hit in liquids.

It seems that the average distance the pollen particle has moved after n collisions should be zero, because all velocities are random. However, this is wrong, as experiment shows.

It is not known in which direction the particle moves, but it moves. An average *square* displacement, written $\langle d^2 \rangle$, is observed. If the distance the particle moves after one collision is l , the average square displacement is given, as you should be able to show yourself, by

Challenge 855

$$\langle d^2 \rangle = nl^2 \tag{72}$$

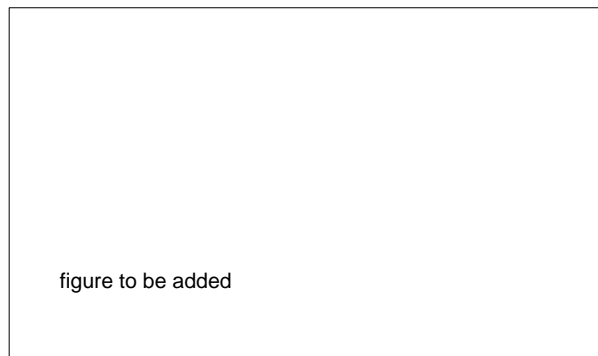

Figure 71 A typical path for a particle undergoing Brownian motion, its displacement distribution, and its average square displacement

For molecules with an average velocity v this gives

$$nl^2 = vlt \tag{73}$$

In other words, the average square displacement increases proportionally with time. Repeatedly measuring the position of a particle should give the distribution shown in Figure 71 for the probability that the particle is found at a given distance from the starting point. This is called the (*Gaussian*) *normal distribution*. In 1908, the French physicist Jean Perrin (1870–1942) performed extensive experiments in order to test this prediction. He found complete

Ref. 140

* A *thermodynamic degree of freedom* is, for each particle in a system, the number of dimensions in which it can move plus the number of dimensions in which it is kept in a potential. Atoms in a solid have six, whereas particles in monoatomic gases have only three.

An excellent introduction into the physics of heat is the book by LINDA REICHL, *A Modern Course in Statistical Physics*, Wiley, 2nd edition, 1998.

** The important Austrian physicist Ludwig Boltzmann (1844, Wien–1906) is most famous for his work on thermodynamics, in which he explained all thermodynamic phenomena, inclusive entropy, as results of the behaviour of atoms. The naming of the Boltzmann constant resulted from these investigations. He was one of the most important physicists of the ending 19th century, and stimulated many developments which then lead to quantum theory. It is said that Boltzmann committed suicide partly because of the resistance of the scientific establishment to his ideas, which are standard material nowadays.

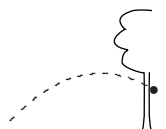

correspondence of equation (73) with observations, thus convincing everybody that Brownian motion is indeed due to hits by the molecules of the surrounding liquid, as Einstein had predicted.*

Einstein also showed that the same experiment could be used to determine the number of molecules in a litre of water. Can you find out how?

Challenge 872

Why do balloons take up space?

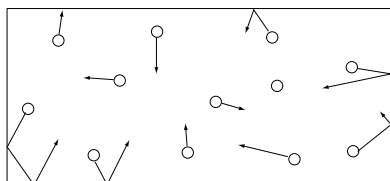

Figure 72 The basic idea of statistical mechanics about gases

Only with the idea that matter is made of small particles were people able to understand gases.** In particular, it became clear that the *pressure* of a gas in a container is produced by the steady flow of particles hitting the wall. It is not difficult to show that if the particles are assumed to behave as tiny, hard and perfectly elastic balls, the quantities pressure p , volume V , and temperature T must be related by

$$pV = \frac{3}{2}NkT \quad (74)$$

Challenge 889

where N is the number of particles contained in the gas. A gas made of particles with such textbook behaviour is called *ideal gas*. The relation is confirmed by experiment at room and higher temperatures, and thus provides another argument for the existence of atoms and their behaviour as normal, though small objects. (Can you imagine how N may be determined experimentally?)

Challenge 906

The ideal gas relation (74) allows an easy measurement of temperature itself. Indeed, temperature has been defined and measured for about a century in this way. Most importantly of all, the ideal gas relation shows that there is a lowest temperature in nature, namely that temperature at which an ideal gas would have a vanishing volume. Sloppily speaking, this is the case when all particles are at rest. That happens, as is well known, at $T = 0$ K, i.e. at -273.15 °C.

Ref. 142

The underlying approximation of hard constituents without any long-distance interactions is obviously not valid at very low temperatures. However, using improvements of the ideal gas relation (74), taking into account the deviations due to interactions between atoms or molecules, overcomes these limitations and is now standard practice, allowing to measure temperatures even at extremely low values. The effects observed below 80 K, such as the solidification of air, frictionless transport of electrical current, or frictionless flow of liquids, form a fascinating world of their own; however, the beautiful domain of low temperature-physics will not be explored during this walk.

Ref. 143

Ref. 144, 145

But the ideal gas model helps to decide questions such as the one of Figure 73. Two *identical* rubber balloons, one filled up to a larger size than the other, are connected via a pipe and a valve. The valve is opened. Which one deflates?

Challenge 923

Ref. 141 * In a delightful piece of research, Pierre Gaspard and his team showed in 1998 that Brownian motion is also chaotic.

** By the way, the word 'gas' is a modern construct. It was coined by the Brussels alchemist and physician Johan Baptista von Helmont (1579–1644), to sound similar to 'chaos'. It is one of the few words which have been invented by a particular person and then adopted all over the world.

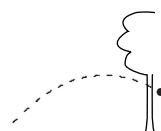

Domain	extensive quantity i.e. energy carrier	current i.e. flow intensity	intensive quantity i.e. driving strength	energy flow i.e. power	resistance to transport i.e. intensity of entropy generation
Rivers	mass m	mass flow m/t	height difference gh	$P = ghm/t$	$R_m = ght/m$ [m ² /s kg]
Gases	volume V	volume flow V/t	pressure p	$P = pV/t$	$R_f = pt/V$ [kg/s m ⁵]
Mechanics	momentum \mathbf{p}	force $\mathbf{F} = d\mathbf{p}/dt$	velocity \mathbf{v}	$P = \mathbf{v}\mathbf{F}$	$R_p = t/m$ [s/kg]
	angular momentum \mathbf{L}	torque $\mathbf{M} = d\mathbf{L}/dt$	angular velocity $\boldsymbol{\omega}$	$P = \boldsymbol{\omega}\mathbf{M}$	$R_L = t/mr^2$ [s/kg m ²]
Electricity	charge q	electrical current $I = dq/dt$	electrical potential U	$P = UI$	$R = U/I$ [Ω]
Thermodynamics	entropy S	entropy flow $I_S = dS/dt$	temperature T	$P = TI_S$	$R_S = Tt/S$ [K ² /W]
Chemistry	amount of substance n	substance flow $I_n = dn/dt$	chemical potential μ	$P = \mu I_n$	$R_n = \mu t/n$ [Js/mol ²]

Table 22 Extensive quantities in nature, i.e. quantities which *flow* and *accumulate*

Challenge 940

Now you are able to take up the following challenge: how can you measure the weight of a car with a ruler only?

Entropy

- It's irreversible.
- Like my raincoat!
Mel Brooks, *Spaceballs*, 1987.

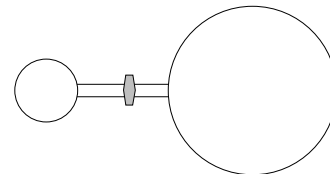
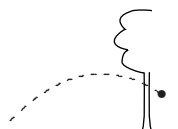

Figure 73 Which balloon wins?

Ref. 148

Every domain of physics describes change with two quantities: energy and an extensive quantity characteristic of the domain. Table 22 provides an overview. An observable is called extensive if it increases with system size. Even though heat is related energy, the quantity physicists call heat is *not* an extensive quantity. Worse, what physicists call heat is not the same as what we call heat in our everyday experience. The extensive quantity corresponding to what is called ‘heat’ in everyday language is called *entropy*,* in the same way as momentum is the extensive quantity describing motion. When two objects differing in temperature are brought into contact, an entropy flow takes place between them, like the flow of momentum taking place when two objects of different speed collide. Let us define the concept of entropy more precisely and explore its properties in some more detail.

* The term ‘entropy’ was invented by the German physicist Rudolph Clausius (1822–1888) in 1865. He formed it from the Greek ἐν ‘in’ and τροπή ‘direction’, to make it sound similar to energy. It always had the meaning given here.



Material	Typical entropy per particle
Monoatomic solids	0.3-10 k
Diamond	0.29 k
Graphite	0.68 k
Lead	7.79 k
Monoatomic gases	15-25 k
Helium	15.2 k
Radon	21.2 k
Diatomic gases	15-30 k
Polyatomic solids	10-60 k
Polyatomic liquids	10-80 k
Polyatomic gases	20-60 k
Icosane	112 k

Table 23 Some typical entropy values per particle at *standard* temperature and pressure as multiples of the Boltzmann constant

First of all, the entropy is proportional to the volume of the system under consideration. Like any other extensive quantity, entropy can be accumulated in a body; it can flow in or out of bodies. When water is transformed into steam, the entropy added is indeed contained in the steam. In short, entropy should be called ‘heat’.

In contrast to other extensive quantities, entropy is not conserved. However, it is ‘half’ conserved: entropy does not decrease, but it can and usually does increase in a closed system.

When a piece of rock detaches from a mountain, it falls, tumbles into the valley, heating up a bit, and eventually stops. The opposite process, that a rock cools and tumbles upwards, is never observed. Why? The opposite motion does not contradict any rule or pattern about motion that we have deduced so far.

Rocks never fall upwards because mountains, valleys and rocks are made of many particles. Motions of many-particle systems, especially in the domain of thermostatics, are called *processes*. Central to thermostatics is the distinction between *reversible* processes, such as the flight of a stone, and *irreversible* processes, such as the mentioned tumbling rock. Irreversible processes are all those processes in which friction and its generalisations play a role. They are important: if there were no friction, shirt buttons and shoelaces would not stay fastened, we could not walk or run, coffee machines would not make coffee, and maybe most importantly of all, our memory would not work.

Irreversible processes transform macroscopic motion into the disorganized motion of all the small microscopic components involved. It is therefore not impossible to reverse irreversible motion; it is only extremely improbable. Entropy measures the amount of irreversibility; in a sense it measures the degree of decay a collective motion has undergone.

Entropy is not conserved. Entropy – ‘heat’ – can appear out of nowhere. For example, when two liquids at room temperature are mixed, the temperature of the mix can differ, depending on the materials. When current flows through a room temperature body, the system can heat up or cool down, depending on the material.

Challenge 957

See page 551

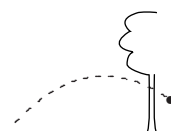

Entropy is not conserved. The second principle of thermodynamics states that ‘entropy isn’t what it used to be.’ More precisely, *the entropy in a closed system tends towards its maximum*. Here, a *closed system* is a system which does not exchange energy or matter with its environment. Can you think of an example?

Challenge 974

Entropy never decreases. Everyday life shows that in a closed system, the disorder increases with time, until it reaches some maximum. To reduce disorder, we need effort, i.e. work and energy. In other words, in order to reduce the disorder in a system, we need to connect the system to an energy source in some smart way. Refrigerators need electrical current precisely for this reason.

Entropy never decreases. As a consequence, *white colour does not last*. Whenever disorder increases, the colour white becomes ‘dirty’, usually grey or brown. Perhaps for this reason white objects, such as white clothes, white houses and white underwear, are so valued in our society. White objects defy decay.

Entropy allows to define the concept of equilibrium more precisely as the state of maximum entropy. Note that for any system whose entropy S increases, the increase is due to contact with some bath. (More precisely, this is correct for systems which are not driven by outside influences; in this latter case, entropy can be produced inside the system.)

Ref. 149

– CS – Some parts to be added. – CS –

Once it became clear that heat and temperature are due to the motion of microscopic particles, people asked what entropy was microscopically. The answer can be formulated in various ways; the two most extreme answers are:

- Entropy is the expected number of yes-no questions, multiplied by $k \ln 2$, needed to be answered for knowing everything about the system, i.e. for knowing its microscopic state.
- Entropy measures the (logarithm of the) number W of possible microscopic states. A given macroscopic state can have many microscopic realizations. The logarithm of this number, multiplied by the Boltzmann constant k gives the entropy. Therefore the formula $S = k \ln W$ was inscribed by Max Planck on the tomb of Boltzmann.

In short, the higher the entropy, the more microstates are possible. Through either of these definitions, entropy measures the quantity of randomness in a system; in other words, it measures the transformability of energy; higher entropy means lower transformability. For example, when a molecule of glucose (a type of sugar) is produced by photosynthesis, about 40 bits of entropy are released. This means that after the glucose is formed, 40 additional yes/no questions must be asked to know again the full microscopic state of the system. Physicists often use a macroscopic unit; most systems are large, and thus 10^{23} bits are abbreviated as 1 J/K.*

Ref. 150

To sum up, entropy is thus a specific measure for the characterization of disorder of thermal systems. Three points are worth mentioning. First of all, entropy is not *the* measure for disorder, but *one* measure for disorder. It is therefore *not* correct to use entropy as a *synonym* for the concept of disorder, as is often done in the popular literature. Entropy is only defined for systems which have a temperature, in other words, only for systems which are in or near equilibrium. (For systems far from equilibrium, no measure for disorder

Challenge 991 * This is only approximate; can you find the precise value?

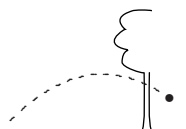

has been found yet; probably none is possible.) In fact, the use of the term entropy has degenerated so much that sometimes one has to call it *thermodynamical* entropy for clarity.

Secondly, entropy is related to information *only if* information is defined also as $-k \ln W$. To make this point clear, take a book of about one kilogram of mass. At room temperature, its entropy content is about 4 kJ/K. The printed information inside a book, say 500 pages of 40 lines with each 80 characters out of 64 possibilities, corresponds to an entropy of $4 \cdot 10^{-17}$ J/K. In short, what is usually called ‘information’ in everyday life is a negligible fraction of what a physicist calls information. Entropy is defined using the *physical* concept of information.

Finally, entropy is also *not* a measure for what in normal life is called the *complexity* of a situation. In fact, nobody has yet found a quantity describing this everyday experience. The task is surprisingly difficult. Have a try!

Ref. 151
Challenge 1008

In summary, if you hear the term entropy used with a different meaning than $S = k \ln W$, beware. Somebody is trying to get you, probably with some ideology.

We know from daily experience that transport of an extensive quantity always includes friction. Friction implies generation of entropy. In particular, the flow of entropy itself produces additional entropy. For example, when a house is heated, entropy is produced in the wall. Heating means to keep a temperature difference between the interior and the exterior of the house. The heat flow J traversing a square meter of wall is given by

$$J = \kappa(T_i - T_e) \quad (75)$$

where κ is a constant characterizing conduction ability of the wall. While conducting, the wall also produces entropy. The entropy flow σ is proportional to the difference of entropy flows between the interior and the exterior. In other words, one has

$$\sigma = \frac{J}{T_e} - \frac{J}{T_i} = \kappa \frac{(T_i - T_e)^2}{T_i T_e} \quad (76)$$

Note that we assumed in this calculation that everything is near equilibrium in each slice parallel to the wall, a reasonable assumption in everyday life. A typical case of a good wall has $\kappa = 1 \text{ W/m}^2\text{K}$ in the range between 273 K and 293 K. One gets an entropy flow of

$$\sigma = 5 \cdot 10^{-3} \text{ W/m}^2\text{K} \quad (77)$$

Can you compare the amount of entropy produced in the flow with the amount transported? In comparison, a good goose feather duvet has $\kappa = 1.5 \text{ W/m}^2\text{K}$, which in shops is also called 15 tog.*

Challenge 1025

There are two other ways, apart from heat conduction, to transport entropy: *convection*, used for heating houses, and *radiation*, which is possible also through empty space. For example, the earth radiates about $1.2 \text{ W/m}^2\text{K}$ into the cosmos, in total thus about 0.51 PW/K.

* That unit is not yet as bad as the official (not a joke) $\text{BthU} \cdot \text{h}/\text{sqft}/\text{cm}/^\circ\text{F}$ used in some remote provinces of our galaxy.

The insulation power of materials is usually measured by the constant $\lambda = \kappa d$ which is independent of the thickness d of the insulating layer. Values in nature range from about $2000 \text{ W/m} \cdot \text{K}$ for diamond, which is the best conductor of all, down to $0.1 \text{ W/m} \cdot \text{K}$ to $0.2 \text{ W/m} \cdot \text{K}$ for wood, a range between $0.015 \text{ W/m} \cdot \text{K}$ and $0.05 \text{ W/m} \cdot \text{K}$ for wools, cork and foams, and the small value of $5 \cdot 10^{-3} \text{ W/m} \cdot \text{K}$ for krypton gas.

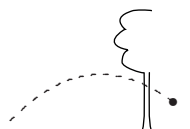

The entropy is (almost) the same that the earth receives from the sun. If more entropy had to be radiated away, the temperature of the surface of the earth would have to increase. This is called the *greenhouse effect*. Let's hope that it remains small in the near future.

Do isolated systems exist?

In all the discussions so far, we assumed that we could distinguish the system under investigation from the environment. In fact we assumed that at least in principle such *isolated* or *closed* systems, i.e. systems not interacting with their environment, actually exist. Probably our own human condition was the original model for the concept; we do experience having the possibility to act independently of the environment. Following this model, an isolated system is a system not exchanging any energy or matter with its environment. For many centuries experiments have shown no reason to question this definition.

The concept of an isolated system had to be refined somewhat with the advent of quantum mechanics. Nevertheless, the concept provides useful and precise descriptions of nature also in that domain. Only in the third part of our walk the situation will change drastically. There, the investigation of whether the universe is an isolated system will lead to surprising results.

Challenge 1042 (What do you think?)* We'll take the first steps towards the answer shortly.

Why can't we remember the future?

It's a poor sort of memory which only works backwards.
Lewis Carroll (1832–1898), *Alice in Wonderland*

In the section where time was introduced, right from the start we ignored the difference between past and future. But obviously, a difference exists, as we do not have the ability to remember the future. This is not a limitation of our brain alone. Also the devices around us, such as tape recorders, photographic cameras, newspapers, and books only tell us about the past. Is there a way to build a video recorder with a 'future' button? Such a device would have to solve a deep problem: how would it distinguish between the near and the far future? It does not take much to find out that any way to do this conflicts with the second principle of thermodynamics. That is bad luck, as we would need precisely the same device to show that there is faster than light motion. Can you find the connection?

Challenge 1059

Challenge 1076

In summary, the future cannot be remembered because entropy in closed systems tends towards a maximum. Put even more simply, memory exists because the brain is made of many particles, and for the very same reason the brain is limited to the past. However, for the most simple types of motion, when only a few particles are involved, the difference between past and future disappears. For few-particle systems, there is no difference between times gone by and times approaching. Even more sloppily, the future differs from the past only in our brain, or equivalently, only because of friction. Therefore the difference between the past and the future is not mentioned frequently in this walk, even though it is an essential part of our human experience. But the fun of the present adventure is precisely to overcome our limits.

* A strange hint: your answer is most probably wrong.

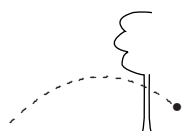

Is everything made of particles?

A physicist is an atom's way of knowing about atoms.
George Wald

Historically, the study of statistical mechanics has been of fundamental importance for physics. It was the first demonstration that physical objects are made of interacting particles. The story of the topic is in fact a long chain of arguments showing that all properties we ascribe to objects, such as size, stiffness, colour, mass density, magnetism, thermal or electrical conductivity, result from the interaction of the many particles they consist of. The discovery that *all objects are made of interacting particles* has often been called the main result of modern science.

How was composition discovered? Table 22 lists the main extensive quantities used in physics. Extensive quantities are able to flow. It turns out that all flows in nature are composed of elementary processes. We saw that the flow of mass, volume, charge, entropy and substance are composed. Later, quantum theory will show the same for the flow of linear and angular momentum. *All flows are made of particles.*

See page 152

This conceptual success has led many people to generalize it to the statement: 'Everything we observe is made of parts.' This approach has been applied with success to chemistry with molecules, * material science and geology with crystals, electricity with electrons, atoms with elementary particles, space with points, time with instants, light with photons, biology with cells, genetics with genes, neurology with neurons, mathematics with sets and relations, logic with elementary propositions, and even to linguistics with morphemes and phonemes. All these sciences have flourished on the idea that everything is made of related *parts*. The basic idea seems so self-evident that we have difficulties even in naming an alternative. Just try.

Challenge 1093

However, in the case of the *whole* of nature this idea is incorrect. It turns out to be a prejudice, and a prejudice so entrenched that for at least thirty years it has retarded further developments in physics. In particular, it does *not* apply to elementary particles and to space-time. Finding the correct description is the biggest challenge of our adventure, as it requires a complete change in thinking habits. There is a lot of fun ahead.

See page 715

Jede Aussage über Komplexe läßt sich in eine Aussage über deren Bestandteile und in diejenigen Sätze zerlegen, welche die Komplexe vollständig beschreiben. **

Ludwig Wittgenstein, *Tractatus*, 2.0201

Curiosities and fun challenges about heat

Even though heat is disordered motion, it follows simple but surprising rules.

- If heat really is disordered motion of atoms, a big problem appears. When two atoms collide head-on, in the instant of smallest distance, none has velocity. Where did the kinetic energy go? Obviously, it is transformed into potential energy. But that implies that atoms can

* A fascinating introduction into chemistry is the text by JOHN EMSLEY, *Molecules at an Exhibition*, Oxford University Press, 1998.

** Every statement about complexes can be resolved into a statement about their constituents and into the propositions that describe the complexes completely.



be deformed, that they have internal structure, and thus that they can be split. In short, if heat is disordered atomic motion, *atoms are not indivisible!* In the 19th century this argument was brought forward in order to show that heat cannot be atomic motion, but must be some sort of fluid. But since heat really is kinetic energy, atoms are indeed divisible, even though their name means ‘indivisible’. We do not need any expensive experiment to show this.

▪ Mixing 1 kg of water at 0 °C and 1 kg of water at 100 °C gives 2 kg of water at 50 °C.
 Challenge 1110 What is the result of mixing 1 kg of *ice* at 0 °C and 1 kg of water at 100 °C?

Ref. 146

▪ The highest recorded air temperature in which a man survived is 127 °C. This was tested in 1775 in London, by the secretary of the Royal Society, Blagden, together with a few friends, who remained in a room of that temperature for 45 minutes. Interestingly, the steak which he had taken with him was cooked ‘well done’ when he and his friends left the room. What condition had to be strictly followed in order to avoid cooking the people in the same way as the steak?

Challenge 6

Challenge 23

Challenge 40

▪ Why does water boil at 99.975 °C instead of 100 °C?

▪ Can you fill a bottle precisely with 1 ± 10^{-30} kg of water?

▪ If you do not like this text, here is a proposal. You can use the paper to make a cup, as shown in Figure 74, and boil water in it over an open flame. However, to succeed, you have to be a little careful. Can you find out in what way?

Challenge 57

▪ One gram of fat contains 38 kJ of chemical energy (or, in old units more familiar to nutritionists, 9 kcal). That is the same value as that of car fuel. Why are people less dangerous?

Challenge 74

▪ A famous exam question: How can you measure the height of a building with a barometer, a rope, and a ruler? Find at least six different ways.

Challenge 91

▪ What is the probability that out of one million throws of a coin you get exactly 500 000 heads and as many tails? You may want to use Stirling’s formula: $n! \approx \sqrt{2\pi n} (n/e)^n$ to calculate the result.

Challenge 108

▪ By the way, does it make sense to say that the universe has an entropy?

Challenge 125

Challenge 142

▪ Can a helium balloon lift the tank which filled it?

▪ All friction processes, such as osmosis, diffusion, evaporation, or decay, are *slow*. They take a characteristic time. It turns out that any (macroscopic) process with a time-scale is irreversible. This is no real news: we know intuitively that undoing things always takes more time than doing them. That is the second principle of thermodynamics.

▪ It turns out that *storing* information is possible with negligible entropy generation. However, *erasing information* requires entropy. This is the prettiest result of the discussions on irreversibility of macroscopic motion. This is the main reason that computers, as well as brains, require energy sources and cooling systems even if their mechanisms would need no energy at all.

Ref. 147

▪ When mixing hot rum and cold water, how does the entropy

Challenge 159

increase due to the mixing compared to the increase due to the temperature difference?

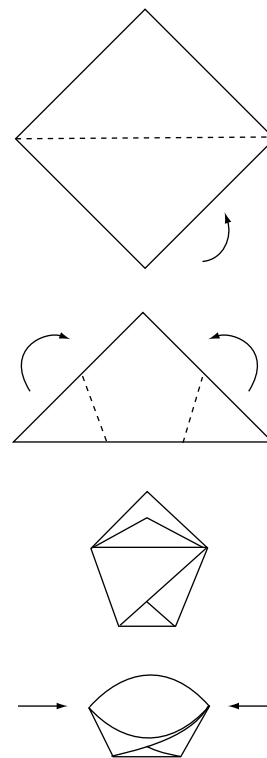
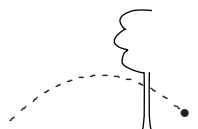

Figure 74 Are you able to boil water in this paper cup?



▪ Why aren't there any small humans, e.g. 10 mm in size, as in many fairy tales? In fact, there are no warm-blooded animals of that size of any kind at all. Why?

Challenge 176

▪ Shining light onto a body and repeatedly switching it on and off produces sound. This is called the *photoacoustic effect*, and is due to the thermal expansion of the material. By changing the frequency of the light, and measuring the intensity of the noise, one gets a characteristic photoacoustic *spectrum* for the material. This method allows the detection of gas concentrations in air of 1 part in 10^9 . It is used among others to study the gases emitted by plants. Plants emit methane, alcohol and acetaldehyde in small quantities; the photoacoustic effect can detect these gases and help understanding the processes behind their emission.

▪ What is the rough probability that all oxygen molecules in the air move away from a given city for a few minutes, killing all inhabitants?

Challenge 193

▪ If you pour a litre of water into the sea, stir thoroughly through all oceans and then take out a litre of the mixture, how many of the original atoms will you find?

Challenge 210

▪ How long could you breathe in the room you are in if it were airtight?

Challenge 227

▪ Entropy calculation is often surprising. For a system of N particles with two states each, there are $W_{\text{all}} = 2^N$ states. For its most probable configuration, with exactly half the particles in one state, and the other half in the other state, we have $W_{\text{max}} = N!/((N/2)!)^2$. Now, for a macroscopic amount of particles, we typically have $N = 10^{24}$. That gives $W_{\text{all}} \gg W_{\text{max}}$; indeed, the former is 10^{12} times larger than the latter. On the other hand, we find that $\ln W_{\text{all}}$ and $\ln W_{\text{max}}$ agree for the first 20 digits! Even though the configuration with exactly half particles in each state is much more rare than the general case, where the number ratio is allowed to vary, the entropy turns out to be the same. Why?

Challenge 244

Challenge 261

▪ If heat is due to motion of atoms, our built-in senses of heat and cold simply are detectors of motion. How could they work?

Challenge 278

By the way, the senses of smell and taste can also be seen as motion detectors, as they signal the presence of molecules flying around in air or in liquids. Do you agree?

Challenge 295

▪ The moon has an atmosphere as well, although an extremely thin one, consisting of sodium (Na) and potassium (K). It has been detected up to nine moon radii from its surface. The atmosphere of the moon is generated from the surface by the ultraviolet radiation from the sun. Can you estimate the moon's atmospheric density?

Challenge 312

▪ Does it make sense to add a line in Table 22 for the quantity of action? Why?

Challenge 329

▪ Diffusion provides a length scale. For example, insects take up oxygen through their skin. As a result, the interior of their bodies cannot be much more distant from the skin than about a centimetre. Can you list other length scales produced by diffusion?

Challenge 346

▪ Thermometers based on mercury can reach 750°C . How is this possible, given that mercury boils at 357°C ?

Challenge 363

▪ It is possible to build a power station by building a large chimney, so that air heated by the sun flows upward in it, driving a turbine doing so. It is also possible to realize a power station by building a long vertical tube, letting a gas such as ammonia rise into it which is then liquefied at the top by the low temperatures in the upper atmosphere; when it falls back down a second tube as a liquid – just like rain – it would drive a turbine. Why are such schemes, which are almost completely pollution free, not used yet?

Challenge 380

▪ One of the most surprising devices is the *Wirbelrohr* or Ranque-Hilsch vortex tube. By blowing compressed room temperature air into it at its midpoint, two flows of air are formed

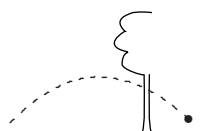

Challenge 397 at its ends. One is extremely cold, easily as low as $-50\text{ }^{\circ}\text{C}$, and one extremely hot, up to $200\text{ }^{\circ}\text{C}$. No moving parts and no heating devices are found inside. How does it work?

▪ What happens to entropy when gravitation is taken into account? We carefully left it out of the picture. In fact, many problems appear – just have a try to study the issue. Jakob Bekenstein stated that the state of highest entropy of matter is attained when the matter forms a black hole. Can you confirm this?

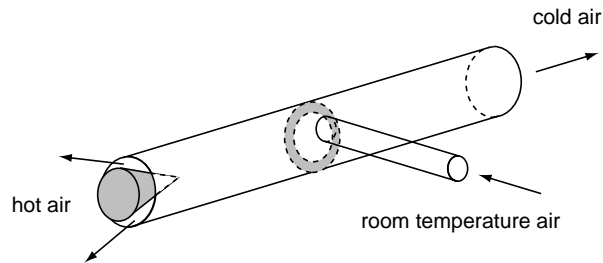

Figure 75 The Ranque-Hilsch vortex tube

Challenge 414

After this short trip into thermostatics, let us have an even shorter look at one aspect of thermodynamics.

Self-organization and chaos

The study of non-linear physics is like the study of non-elephant biology.

Challenge 431

Self-organization is the most general of all descriptions of motion. It studies the appearance of order. *Order* is the collective term for *shape*, such as the complex symmetry of snow flakes, for *pattern*, such as the stripes of zebras, and for *cycle*, such as the creation of sound when singing. You might check that every example of what we call *beauty* is a combination of shapes, patterns and cycles. Self-organization can thus simply be called the study of the origin of beauty.

Order appearance is found from the cell differentiation in an embryo inside a woman's body, the formation of colour patterns on tigers, tropical fish and butterflies, to the formation of the symmetrical arrangements of flower petals and the formation of biological rhythms.

Fluids also provide a large number of phenomena where appearance and disappearance of order can be studied. The flickering of a burning candle, the flapping of a flag in the wind, the regular stream of bubbles emerging from small irregularities in the surface of a champagne glass or the regular or irregular dripping of a water tap are examples.

All growth processes are self-organization phenomena. Have you ever pondered the growth of teeth, where a practically inorganic material forms shapes in the the upper and the lower rows fitting exactly into each other? Also the formation, before and after birth, of neural networks in the brain is a process of self-organization. Even the physical processes

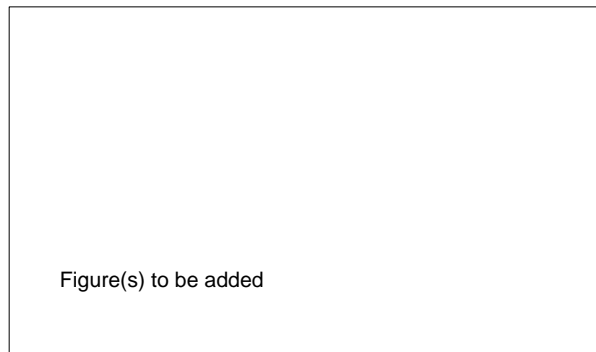
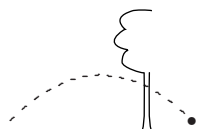

Figure 76 Examples of self-organization for sand



at the basis of thinking, with all its changing electrical signals, should at least partly be described along these lines.

Also biological evolution is a special case of growth. Wherever an aspect can be described quantitatively, the topic becomes fascinating. For example, take the evolution of animal shapes: it turns out that snake tongues are forked because that is the most efficient shape for following chemical trails left by prey and conspecifics. Also the fixed number of petals of flowers are consequences of self-organisation.

Ref. 152
See page 476

Many problems of self-organization are mechanical problems, such as the formation of mountain rows when continents move, the creation of earthquakes, or the creation of regular cloud arrangements in the sky. Pondering the mechanisms behind the formation of clouds you see from an aeroplane can transform a boring flight into a fascinating intellectual adventure.

Challenge 448

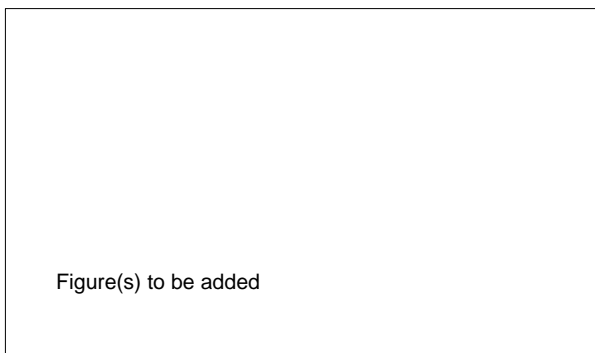

Figure 77 An oscillon formed by shaken bronze balls

Studies into the conditions required for order appearance or disappearance have shown that description requires only a few common concepts, independently of the physical system. This is best seen looking at a few examples.

All the richness of self-organization is shown by the study of plain sand. Why do sand dunes have ripples, as does the sand floor at the bottom of the sea? People also study how avalanches form on

steep heaps and how sand behaves in hourglasses, in mixers, or in vibrating containers. Results are often surprising. For example, only recently Umbanhowar and Swinney have found that when a flat container with tiny bronze balls (less than a millimetre in diameter) is shaken up and down in vacuum at certain frequencies, the surface of this bronze ‘sand’ shows stable heaps. These heaps, so-called oscillons, also bob up and down. They can move and interact with other heaps. In fact, sand and dust is proving to be such a beautiful and fascinating topic that the prospect of each human becoming dust again does not look so grim at all.

Ref. 153

A second, simple and beautiful example of self-organization is the effect discovered in 1999 by Klaus Kötter and his group. They found that the behaviour of a set of spheres swirled in a dish depends on the number of spheres used. Usually, all spheres get continuously mixed up. For certain ‘magical’ numbers, such as 21, stable ring patterns emerge, for which outside spheres remain outside, and inside ones remain inside. The rings are best visualized by colouring the spheres.

Ref. 154

These and many other studies of self-organizing systems have changed the description of nature in a number of ways. First of all, it was shown that patterns and shapes are similar to cycles: all are due to motion. Without motion, and thus without history, there is no order. There are neither patterns nor shapes. Every pattern has a history; every pattern is an example of motion.

Ref. 155

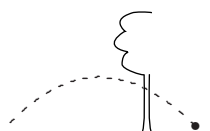

Secondly, patterns, shapes and cycles are due to the organized motion of large numbers of small constituents; systems which self-organize are always composite and *cooperative structures*.

Thirdly, all these systems show evolution equations which are *nonlinear* in the configuration variables. Linear systems do not self-organize. Many self-organizing systems also show *chaotic* motion.

Fourthly, the appearance and disappearance of order depends on the strength of a driving force, the so-called *order parameter*. Often, chaotic motion appears when the driving is increased beyond the value necessary for the appearance of order. An example of chaotic motion is turbulence, which appears when the order parameter, which is proportional to the speed of the fluid, is increased to high values.

Moreover, all order and all structure appears when two general types of motion compete with each other, namely a ‘driving’, energy adding process, and a ‘dissipating’, braking mechanism. There is no self-organization without thermodynamics playing a role. Self-organizing systems are always *dissipative systems* and far from equilibrium. When both the driving and the dissipation are of the same order of magnitude, and when the key behaviour of the system is not a linear function of the driving action, order may appear.*

All self-organizing systems at the onset of order appearance can be described by equations of the general form

$$\frac{\partial A(t, x)}{\partial t} = \lambda A - \mu |A|^2 A + \kappa \Delta A + \text{higher orders} \quad . \quad (78)$$

Here, the – possibly complex – observable A is the one which appears when order appears, such as the oscillation amplitude or the pattern amplitude. We note the driving term λA in which λ describes the strength of the driving, the nonlinearity in A , and the dissipative term ΔA . In cases that the dissipative term plays no role ($\kappa = 0$), when λ increases above zero, a *temporal* oscillation, i.e. a stable cycle with nonvanishing amplitude appears.

In case that the diffusive term does play a role, equation (78) describes how an amplitude for a *spatial* oscillation appears when the driving parameter λ becomes positive, as the solution $A = 0$ then becomes unstable.

In both cases, the onset of order is called a *bifurcation*, because at this critical value of the driving parameter λ the situation with amplitude zero, i.e. the disordered state, becomes unstable, and the ordered state becomes stable. *In nonlinear systems, order is stable*. This is the main conceptual result of the field. But the equation (78) and its numerous variations allow to describe many additional phenomena, such as spirals, waves, hexagonal patterns, topological defects, some forms of turbulence, etc. The main point is to distil the observable

* When you wish to describe the ‘mystery’ of human life, often terms like ‘fire’, ‘river’, or ‘tree’ are used as analogies. They all are examples of self-organized systems; they have many degrees of freedom, have competing driving and breaking forces, depend critically on the initial conditions, show chaos and irregular behaviour, and sometimes show cycles and regular behaviour. Humans and their life resemble them in all these aspects; thus there is a solid basis to their use as metaphors. We could even go further and speculate that pure beauty is pure self-organization. The lack of beauty indeed often results from a disturbed equilibrium between external breaking and external driving.

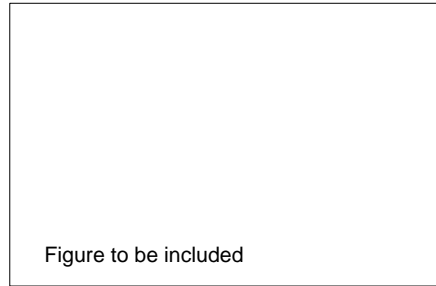
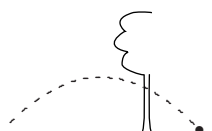

Figure 78 Magic numbers of spheres swirled in a dish

Challenge 465

Challenge 482

Ref. 156



A and the parameters λ , μ and κ from the physical system under consideration.

Self-organization is a vast field that is yielding new results almost by the week. In addition, to discover new topics of study, it is often sufficient to keep one's eye open; most effects are in the reach of high school students. Good hunting!

Challenge 499

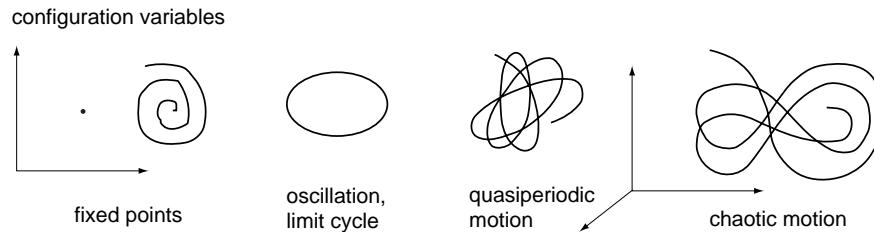

Figure 79 Examples of different types of motion in configuration space

When the driving parameter is increased as much as possible, order becomes more and more irregular, and at the end one usually finds chaos. For physicists, c^{∞} motion is the most irregular type of motion. * Chaos can be defined independently of self-organization, namely as that motion of systems for which small changes in initial conditions evolve into large changes of the motion, as shown in Figure 80. The weather is such a system, but it turns out that also dropping faucets, many flows of liquids, the fall of dice, and many other systems are chaotic. For example, research on the mechanisms by which the heart beat is generated showed that the heart is not an oscillator, but a chaotic system with irregular cycles. This allows the heart to be continuously ready for demands of changes in beat rate which appear once the body has to increase or decrease its efforts.

Ref. 123

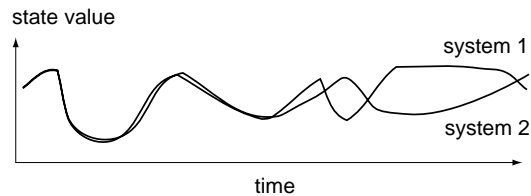

Figure 80 Sensitivity to initial conditions

As a note, can you show with simple words that the butterfly effect does not exist? The effect is an invention of newspapers; they claim that nonlinearity means that a small change in initial conditions can lead to large effects; thus a butterfly wing beat could lead to a tornado. This is wrong.

Challenge 516

And of course there is chaotic motion also in machines: chaos in the motion of trains on the rail, chaos in gear mechanisms, chaos in firemen hoses. The author predicts that the precise study of the motion in a zippo will also yield an example of chaos. The mathematical

* On the topic of chaos, see the beautiful book by H.-O. PEITGEN, H. JÜRGENS & D. SAUPE, *Chaos and fractals*, Springer Verlag, 1992. It includes stunning pictures, the mathematical background, and the computer programs allowing personal exploration. 'Chaos' is an old word; according to Greek mythology, the first goddess, Gaia, i.e. the earth, emerged from the chaos existing at the beginning. She then gave birth to the other gods, the animals, and the first humans.

description of chaos, simple in many textbook examples, but extremely involved in other cases, remains an important topic of research. Despite their fascination we will not study the quasiperiodic and the chaotic cases because they do not lead towards the top of motion mountain.

The steps from disorder to order to chaos, all examples of self-organization, are found in many fluid systems. Their study should lead, one day, to uncover the mysteries of turbulence.

Finally, self-organization is of interest also for a more general reason. Sometimes it is said that the ability to formulate the patterns or rules of nature from observation does not include the ability to predict *all* observations from these rules. In this view, so-called ‘emergent’ properties exist, i.e. properties appearing in complex systems as something *new* that cannot be deduced from the properties of their parts and their interactions. (The ideological background of these views is obvious; it was the last try to fight the deterministic description of the world.) The study of self-organization has definitely settled this debate. The properties of water molecules do allow to predict Niagara falls* and the diffusion of signal molecules do determine the development of a single cell into a full human being. In particular, cooperative phenomena determine the place where arms and legs are formed, they ensure the (approximate) right-left symmetry of human bodies, prevent mix-ups of connections when the cells in the retina are wired to the brain, and explain the fur patterns on zebras and leopards, to cite only a few examples. Similarly, the mechanisms at the origin of the heart beat and many other cycles have been deciphered.

Self-organization provides the general principles which allow to predict the behaviour of complex systems of any kind. They are presently being applied to the most complex system in the universe: the human brain. The details of how it learns to coordinate the motion of the body, and how it extracts information from the images in the eye are being studied. The work ongoing in this domain is fascinating. If you plan to enter science, evaluate taking this path.

Challenge 550

These studies provide the last arguments to confirm what J. Offrey de la Mettrie wrote in 1748 in his famous book *L’homme machine*: humans are complex machines. Indeed, the lack of understanding of complex systems in the past was due mainly to the restrictive teaching of the subject, which usually concentrated – as does this walk – on examples of motion in *simple* systems. Even though self-organization is and will provide fascinating insights for many years to come, we now leave it and continue with our own adventure on the fundamentals of motion.**

5. Limits of Galilean physics – what is wrong with school physics

I only know that I know nothing.

* Already small versions of Niagara fall, namely dripping water taps, show a large range of cooperative phenomena, including the chaotic, i.e. non-periodic, fall of water drops. This happens when the water flow has the correct value, as you might want to test in your own kitchen.

Ref. 157
Challenge 533

** An important case of self-organization is *humour*. An overview of science humour can be found in the famous anthology compiled by R.L. WEBER, edited by E. MENDOZA, *A random walk in science*, Institute of Physics, London 1997. It is also available in several expanded translations.

Socrates (470–399 BCE), as cited by Plato.

We give a few proofs for the truth of this quote in the case of Galilean physics, despite its general success in engineering and in everyday life.

Research topics in classical dynamics

Even though mechanics is now several hundred years old, research into its details is still not concluded.

- We mentioned already above the study of the stability of the solar system. The long-term future of the planets is unknown. In general, the behaviour of few body systems interacting through gravitation is still a research topic of mathematical physics. Answering the simple question on how long a given set of bodies gravitating around each other will stay together is a formidable challenge. This so-called *many-body problem* is one of the seemingly never-ending stories of theoretical physics. Interesting progress has been achieved, but the concluding answer is still missing.

Ref. 158

- The spinning top, and in general the description of rotating bodies, including bicycles, motorcycles and other such ‘dangerous’ contraptions is still ongoing. The mathematical difficulties of this topic fascinate many.

- The challenges of self-organization, of nonlinear evolution equations, and of chaotic motion are still plenty and motivate numerous researchers in mathematics, physics, chemistry, biology, medicine, and the other sciences.

- Perhaps the toughest of all problems in modern physics is the description of *turbulence*. When the young Werner Heisenberg was asked to continue research on turbulence, he refused – rightly so – saying it was too difficult; he turned to something easier and discovered quantum mechanics instead. Turbulence is such a vast topic, with many of the concepts still not settled, that despite the number and importance of its applications, only now, at the beginning of the twenty-first century, its secrets start to be unravelled. It is thought that the equations of motion describing fluids, the so-called *Navier-Stokes equations*, are sufficient to understand them. But the math behind them is mind boggling. There is even a one million dollar prize offered by the foundation Clay at the Collège de France, for certain steps on the way of solving them.

Ref. 159

What is contact?

We defined mass through the measurement of velocity changes during collisions. But why do objects change their motion in such instances? Why are collisions between two balls made of chewing gum different from those between two stainless steel balls? What happens during those moments of contact?

See page 60

Obviously, contact is related to material properties, and they influence motion in a complex way. The complexity is so large that the sciences of material properties developed independently from physics for a long time; for example, the techniques of metallurgy – often called the oldest science of all – of cooking and of chemistry were related to the properties of motion only in the twentieth century, after having been independently pursued for thousands of years. Since material properties determine the essence of contact, we *need*

knowledge about matter and about materials to understand the origin of mass, and thus of motion. The second part of the mountain ascent will uncover these connections.

Precision and accuracy

When we started climbing motion mountain, we stated that to gain height means to increase the *precision* of our description of nature. Well, this statement is itself not precise. It turns out that we have to distinguish between two terms which are often confused: *precision* is the degree of reproducibility; *accuracy* is the degree of correspondence to the actual situation. Both concepts apply to measurements, to statements, and to physical concepts.* Therefore, in our walk concepts have mainly to be *precise*, and descriptions have to be *accurate*. Inaccuracy is a proof of lack of understanding. Instead of ‘inaccurate’ we simply say *wrong*. In other words, in our walk, more than to an increase in the precision of our description of nature, we actually aim at increasing its accuracy.

Challenge 567

What should we think of a car company claiming that the air friction coefficient c_w is 0.375? Or of the claim that the world record in fuel consumption for cars is 2315.473 km/l? Or of a census bureau giving the population of a country with a precision of one person? One lesson we gain from the investigations into measurement errors is that we should never provide more digits for results than we can put our hand into fire for.

See Appendix B

Taking an overview of the most precise and accurate measurements at present, we conclude that the record number of digits is 14. Why so few? Classical physics doesn’t cover this issue. What is the maximum number of digits we can expect in measurements, what is its origin, and how can we achieve it? These questions are still open at this point; they will be covered in the second part of our mountain ascent.

Why is measurement possible?

In the description of gravity given so far, the one that everybody learns – or should learn – at high school, acceleration is connected to mass and distance via $a = GM/r^2$. That’s all. But this simplicity is deceiving. In order to check whether this description is correct, we have to measure lengths and times. However, it is *impossible* to measure lengths and time intervals with any clock or any meter bar based on the gravitational interaction alone! Try to conceive such an apparatus and you will be inevitably lead to disappointment. You always need a non-gravitational method to start and stop the stopwatch. Similarly, when you measure length, e.g. of a table, you have to hold a meter bar or some other device near it. The interaction necessary to line up the meter and the table cannot be gravitational.

Challenge 584

A similar limitation applies even to mass measurements. Try to measure mass using gravitation alone. Any scale or balance needs other, usually mechanical, electromagnetic or optical interactions to achieve its function. Can you confirm that the same applies to speed and to angle measurements? In summary, whatever method we use, *in order to define velocity, length, time, and mass, interactions other than gravity are needed*. In short, our simple ability to measure shows that gravity is not all there is.

Challenge 601

Challenge 618

* For measurements, both precision and accuracy are best described by their *standard deviation*, as explained in Appendix B, on page 819.

A second fact hints that more is awaiting us. We found that not all observers agree on the measurement values of change; indeed, the value of the action of a system depends on the motion of the observer. So far, we have ignored this situation; for a complete description of motion we cannot do that though.

We need the concepts of space, time and mass to *talk* about motion, and we need to be able to talk to everybody. Since we cannot give the term ‘motion’ any meaning as long as we neglect the non-gravitational interactions in nature, we are forced to investigate these other interactions as well. To proceed as quickly as possible, we start studying an example of motion which we mentioned at the beginning but which we excluded from our investigations so far, even though it is used for the definition both of the meter and the second: the motion of light.

6. Special relativity – rest at any speed

Typeset in
July 2002

Light is important for describing motion precisely. We need it every day to read lines such as these; but there are more important reasons. How do we check whether a line or a path of motion is straight? We look along it; in other words, we use light. How do we decide whether a plane is flat? We look across it, * again using light. How do we measure length to high precision? With light. How do we measure time to high precision? With light; once that from the sun was used, nowadays it is light from caesium atoms. In other words, light is important because it is the official standard for *undisturbed motion*. Physics would have evolved much more rapidly if, at some earlier time, light propagation had been recognized as the ideal example of motion.

Ref. 160

But is light a moving phenomenon at all? It was already known in ancient Greece that this can be proven by a simple daily phenomenon, the *shadow*. Shadows prove that light is a moving entity, emanating from the light source, and moving in straight lines. ** The obvious conclusion that light takes a certain amount of time to travel from the source to the surface showing the shadow had already been reached by the Greek thinker Empedocles (ca. 490–ca. 430 BCE).

Challenge 652

We can confirm this result with a different, but equally simple, argument. Speed can be measured. Therefore the *perfect* speed, which is used as the implicit measurement standard, must have a finite value. An infinite velocity standard would not allow measurements at all. Of course, we are implying here that the speed of light actually *is* the perfect speed. We will show this in a minute.

The speed of light is high; therefore it was not measured for the first time until 1676, even though many, including Galileo, had tried to do so earlier. The first measurement was performed by the Danish astronomer Olaf Rømer (1644–1710) when he studied the orbits of the moons of Jupiter. He obtained an incorrect value because he used the wrong value for their distance from earth. However, this was quickly corrected by his peers, including Newton himself. The result was then confirmed most beautifully by the next measurement, which was performed only fifty years later, in 1726, by the astronomer James Bradley (1693–1762). Being English, Bradley thought of the ‘rain method’ to measure the speed of light.

Ref. 162

How can we measure the speed of falling rain? We walk rapidly with an umbrella, measure the angle α at which the rain appears to fall, and then measure our own velocity v . As shown in Figure 81, the velocity c of the rain is then given by

$$c = v / \tan \alpha \quad . \quad (79)$$

* Note that looking along the plane from all sides is not sufficient for this; a surface that a light beam touches right along its length in *all* directions does not need to be flat. Can you give an example? One needs other methods to check flatness with light. Can you specify one?

Challenge 635

** Whenever a source produces shadows, the emitted entity is called *radiation* or *rays*. Apart from light, other examples of radiation discovered through shadows were *infrared rays* and *ultraviolet rays*, which emanate from most light sources together with visible light, and *cathode rays*, which were found to be to the motion of a new particle, the *electron*; shadows also led to the discovery of *X-rays*, which again turned out to be a – high frequency – version of light, *channel rays*, which turned out to be travelling ionized atoms, and the three types of radioactivity, namely α -rays (helium nuclei), β -rays (again electrons), and γ -rays (high energy X-rays) which will be discussed later on. All these discoveries were made between 1890 and 1910; those were the ‘ray days’ of physics.

Ref. 161

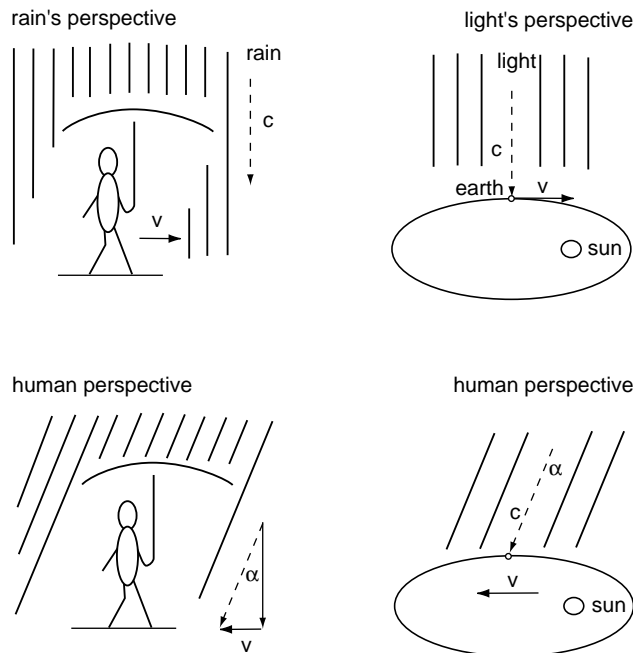

Figure 81 The rain method of measuring the speed of light

The same measurement can be made for light; we just need to measure the angle at which the light from a star above earth's orbit arrives at the earth. This effect is called the *aberration* of light; the angle is best found comparing measurements distant by six months. The value of the angle is $20.5''$; nowadays it can be measured with a precision of five decimal digits. Given that the velocity of the earth around the sun is $v = 2\pi R/T = 29.7 \text{ km/s}$, the speed of light must therefore be $c = 3.00 \cdot 10^8 \text{ m/s}$. * This is quite an astonishing value, especially

* Umbrellas were not common in Britain in 1726; they became fashionable later, after being introduced from China. The umbrella part of the story is made up. In reality, Bradley first understood his unexpected result while sailing on the Thames, when he noted that on a moving ship the apparent wind has a different direction to that on land. He had observed 50 stars for many years, and during that time he had been puzzled by the *sign* of the aberration, which was *opposite* to the effect he was looking for, namely the star parallax.

Challenge 669 By the way, it follows from special relativity that the correct formula is $c = v/\sin\alpha$; can you see why?

To determine the velocity of the earth, its distance to the sun has to be determined. This is done most simply by a method published already by the Greek thinker Aristarchos of Samos (ca. 310–ca. 230 BCE). You measure the angle between the moon and the sun at the moment that the moon is precisely half full. The cosine of that angle gives the ratio between the distance to the moon (determined e.g. via the methods of page 84) and the distance to the sun. The explanation is a puzzle left to the reader.

Challenge 686

The angle in question is almost a right angle (which would yield an infinite distance), and one needs good instruments to measure it precisely, as Hipparchos noted in an extensive discussion of the problem around 130 BCE. The measurement became possible only in the late 17th century, showing that its value is 89.86° , and the distance ratio about 400. Today, through radar measurements of planets, the distance to the sun is known with the incredible precision of 30 metres. Moon distance variations can even be measured down to the 1 centimetre range; can you guess how this is achieved?

Challenge 703

Ref. 50 Aristarchos also determined the radius of the sun and of the moon as multiples of those of the earth. Aristarchos was a remarkable thinker: he was the first to propose the heliocentric system, and perhaps the first to propose that stars were other, far away suns. For these ideas, several contemporaries of Aristarchos proposed

Observations about light

light can move through vacuum;
 the speed of light, its true signal speed, is the forerunner speed;
 in vacuum its value is 299 792 458 m/s;
 light transports energy;
 light has momentum: it can hit bodies;
 light has angular momentum: it can rotate bodies;
 light moves across other light undisturbed;
 light in vacuum always moves faster than any material body does;
 the proper speed of light is infinite;
 shadows can move with no speed limit;
 light moves straight when far from matter;
 light is a wave;
 light beams are approximations;
 in matter, the forerunner speed as well as the energy speed of light are lower than in vacuum;
 in matter, the group velocity of light pulses can have any value, positive or negative, without limits.

Table 24 Properties of the motion of light

when compared with the fastest velocity ever achieved by a man made object, namely the Voyager satellites, which travel at 52 Mm/h = 14 km/s, with the growth of children, about 3 nm/s, or with the growth of stalagmites in caves, about 0.3 pm/s. We begin to realize why it took so long to measure the speed of light. * Table 160 gives a summary about what is known about the motion of light.

The speed of light is so high that it is even difficult to prove that it is *finite*. Perhaps the most beautiful way to prove this is to photograph a light pulse flying across one's field of view, in the same way as one takes the picture of a car driving by or of a bullet flying along. Figure 82 shows the first such

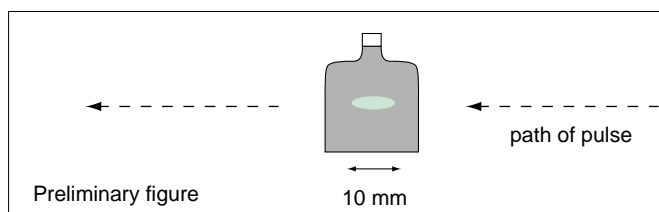

Figure 82 A photograph of a light pulse moving from right to left through milky water, taken by Dugay and Mattick

Ref. 164

Challenge 737

photograph, produced in 1971 with a standard off-the-shelf reflex camera, a very fast shutter invented by the photographers, and, most noteworthy, not a single piece of electronic equipment. (How fast does such a shutter have to be? How would you build such a shutter?

that he should be condemned to death for impiety. When the Polish monk and astronomer Nicolaus Copernicus (1473–1543) repropoed the heliocentric system two thousand years later, he kept this reference unmentioned, even though he got the idea from him.

* The first *precise* measurement of the speed of light was performed in 1849 by the French physicist Hippolyte L. Fizeau (1819–1896). His value was only 5% greater than the modern one. He sent a beam of light towards a distant mirror and measured the time the light took to come back. How far away does the mirror have to be? How do you think did he measure the time, without using any electric device?

Challenge 720

And how would you open it at the right instant?)

In short, light is thus much faster than lightning, as you might like to check yourself. But once the velocity of light could be measured routinely, two surprising properties were discovered in the late nineteenth century. They form the basis of special relativity.

Challenge 754

Ref. 165

Can one play tennis using a laser pulse as ball and mirrors as rackets?

We all know that in order to throw a stone as far as possible, we run as we throw it; we know instinctively that in that case the stone's speed with respect to the ground is higher. However, to the initial astonishment of everybody, experiments show that light emitted from a moving lamp has the same speed as light emitted from a resting one. Many carefully and specially designed experiments confirmed this result to high precision; the speed of light can be measured with a precision of better than 1 m/s, but even for lamp speeds of more than 290 000 000 m/s no differences have been found. (Can you guess what lamps were used?) In short, experiments show that the velocity of light has the *same value* for all observers, even if they are moving with respect to each other or with respect to the light source. The velocity of light is indeed the ideal, perfect measurement standard.*

Ref. 166

Challenge 771

There is also a second set of experimental evidence for the constancy of the speed of light: every electromagnetic device, such as an electric toothbrush, shows that the speed of light is constant. We will discover that magnetic fields would not result from electric currents, as they do every day in every motor and in every loudspeaker, if the speed of light were not constant. This was actually the historical way the constancy was first deduced; only after realizing this connection, did the German–Swiss physicist Albert Einstein** show that the constancy is also in agreement with the motion of bodies, as we will do in this section. The connection between electric toothbrushes and relativity will be detailed in the chapter on electrodynamics.*** In simple words, if the speed of light were not constant, observers would be able to move at the speed of light. Since light is a wave, such observers

Ref. 168

See page 352

* An equivalent alternative term for the speed of light is 'radar speed' or 'radio speed'; we will see below why this is the case.

The speed of light is also (most probably) the same as the speed of neutrinos. This was shown most spectacularly by the observation of a supernova in 1987, when the flash and the neutrino pulse arrived spaced by a few hours. Can you deduce the maximal difference between the two speeds, knowing that the supernova was $1.7 \cdot 10^5$ light years away?

Challenge 788

Experiments also show that the speed of light is the same in all directions of space to at least 21 digits of precision. Other data, taken from gamma ray bursts, show that the speed of light is independent of frequency for its first 20 digits at least.

Ref. 171

Ref. 172

** Albert Einstein (1879, Ulm–1955, Princeton); one of the greatest physicists of all time. He published three important papers in 1905, namely about Brownian motion, about special relativity and about the idea of light quanta. Each paper was worth a Nobel prize, but he was awarded the prize only for the last one. In 1905, he discovered the famous formula $E_0 = mc^2$ (published early 1906). Although one of the founders of quantum theory, he later turned against it. His famous discussions with his friend Niels Bohr nevertheless helped to clarify the field in its most counterintuitive aspects. In 1915 and 1916, he published the general theory of relativity, one of the most beautiful and remarkable works of science ever. Being Jewish and famous, he was a favourite target of attacks and discrimination by the establishment; in 1933 he emigrated to the USA. He was not only a great physicist, but also a great thinker; reading his collection of thoughts about topics outside physics is time well spent.

Ref. 169

Ref. 170

*** For information about the influences of relativity on machine design see the interesting textbook by Bladel.

would see a wave standing still. However, electromagnetism forbids the existence of such a phenomenon. Therefore, observers cannot reach the speed of light.

The constancy of the speed of light is in complete contrast with Galilean mechanics, and proves that the latter is *wrong* at high velocities. At low velocities the description remains good, because the error is small. But if we look for a description valid at *all* velocities, Galilean mechanics has to be discarded. For example, when we play tennis we use the fact that by hitting the ball in the right way, we can increase or decrease its speed. But with light this is impossible. Even if we take an aeroplane and fly after a light beam, it still moves away with the same speed. This is in contrast with cars. If we accelerate a car we are driving, the cars on the other side of the road pass by with higher and higher speeds as we drive faster. For light, this is *not* so; light always passes by with the *same* speed.*

Why is this result almost unbelievable, even though the measurements show it unambiguously? Take two observers O and Ω moving with relative velocity v ; imagine that at the moment they pass each other, a light flash is emitted by a lamp in the hand of O. The light flash moves through positions $x(t)$ for O and through positions $\xi(\tau)$ (pronounced ‘xi of tau’) for Ω (‘omega’). Since the speed of light is the same for both, we have

$$\frac{x}{t} = c = \frac{\xi}{\tau} . \quad (80)$$

However, in the situation described, we obviously have $x \neq \xi$. In other words, the constancy of speed of light implies that $t \neq \tau$, i.e. that *time is different for observers moving relative to each other*. Time is thus not unique. This surprising result, which in the mean time has been confirmed by many experiments, was first stated in detail in 1905 by Albert Einstein. Already in 1895, the discussion of this issue, especially in connection with viewpoint invariance, had been called the *theory of relativity* by the important French mathematician and physicist Henri Poincaré (1854–1912).** Einstein called the description of motion without gravity the theory of *special relativity*, and the description with gravity the theory of *general relativity*. Both fields are full of fascinating and counterintuitive results. In particular, they show that Galilean physics is wrong at high speeds.

Obviously, many people tried to find arguments to avoid the strange conclusion that time differs from observer to observer. But all had to bow to the experimental results. Let us have a look at some of them.

Acceleration of light and the Doppler effect

Light *can* be accelerated. Every mirror does this! We will see in the chapter on electromagnetism that matter also has the power to *bend* light, and thus to accelerate it. However, it will turn out that all these methods only change the propagation direction; none has the power to

* Indeed, the presently possible measurement precision of $2 \cdot 10^{-13}$ does not allow to discern any changes of the speed of light with the speed of the observer.

** The most beautiful and simple introduction to relativity is still given by Albert Einstein himself, such as in *Über die spezielle und allgemeine Relativitätstheorie*, Vieweg, 1997, or in *The meaning of relativity*, Methuen, London, 1951. See also his text *Relativity, the special and general theory*, which can also be found at http://ourworld.compuserve.com/homepages/eric_baird/re1_main.htm. Only a century later there are books

almost as beautiful, such as the text by Taylor and Wheeler.

Challenge 805

Ref. 173

Ref. 168

See page 368

Ref. 171

Ref. 167

change the speed of light in a vacuum. In short, light is an example of motion which cannot be stopped. Only a few other examples exist. Can you name one? any other

Challenge 822

What would happen if we could accelerate light to higher speeds? It would mean that light is made of particles with non-vanishing mass. Physicists call such particles *massive* particles. If light had mass, it would be necessary to distinguish the ‘massless energy speed’ c from the speed of light c_l , which then would be lower and depend on the kinetic energy of those massive particles. The speed of light would not be constant, but the massless energy speed would still be so. Massive light particles could be captured, stopped, and stored in a box. Such boxes would render electric illumination superfluous; it would be sufficient to store in them some daylight and release the light, slowly, the following night.*

Physicists have therefore studied this issue in quite some detail. Observations now put any possible mass of light (particles) at less than $1.3 \cdot 10^{-52}$ kg from terrestrial arguments, and at less than $4 \cdot 10^{-62}$ kg from astrophysical arguments. In other words, light is not heavy, light is light.

Ref. 174

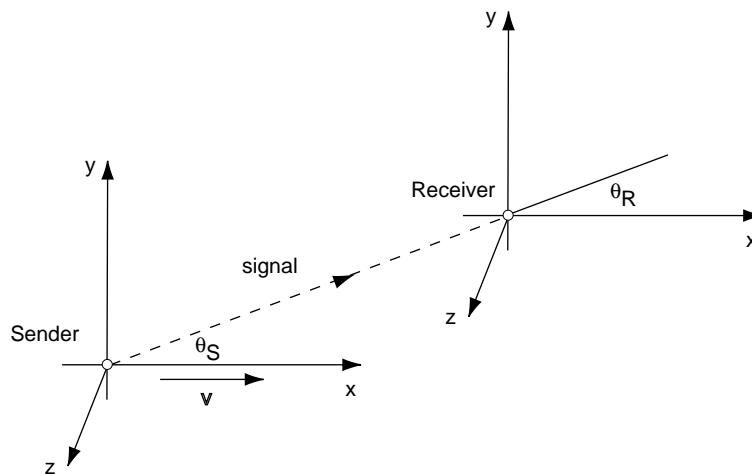

Figure 83 The set-up for the observation of the Doppler effect

But what happens when light hits a *moving* mirror? If the speed of light does not change, something else must. In this case, as in the situation when the light source moves with respect to the receiver, the receiver will observe a *different colour* from that observed by the sender. This result is called the *Doppler effect*. Doppler studied the frequency shift in the case of sound waves – the well-known change in whistle tone between approaching and departing trains.** As we will see later on, light is (also) a wave, and its colour is determined by its frequency. Like the tone change for moving trains, a moving light source produces a colour at the receiver that is different from colour at the sending source. Simple geometry, starting from the fact that all wave maxima and minima emitted must also be received, leads to the result

Challenge 839

* We mention for completeness that massive light would also have *longitudinal* polarization modes, also in contrast to observations, which show that light is polarized exclusively *transversally* to the propagation direction.

** Christian Doppler (1803, Salzburg–1853, Venezia), Austrian physicist.

$$\frac{\lambda_R}{\lambda_S} = \frac{1}{\sqrt{1 - v^2/c^2}} \left(1 - \frac{v}{c} \cos \theta_R\right) = \gamma \left(1 - \frac{v}{c} \cos \theta_R\right) . \quad (81)$$

Light from an approaching source is thus blue shifted, whereas light from a departing source is red shifted. The first observation of the Doppler effect for light was made by Johannes Stark in 1905 * by studying the light emitted by moving atoms. All subsequent experiments confirmed the colour shift within measurement errors; the latest checks found agreement to within two parts per million. In contrast to sound waves, a colour effect is also found when the motion is *transverse* to the light signal. (How does the colour change in this case?)

Ref. 175

Challenge 856

The colour shift is used in many applications. Almost all bodies are mirrors for radio waves. When one enters a building, often the doors open automatically. A little sensor above the door detects the approaching person. Usually, but not always, this is done by measuring the Doppler effect of radio waves emitted by the sensor and reflected by the approaching person. (We will see later that radio waves and light are two sides of the same phenomenon.) Police radar also works in this way. **

The Doppler effect also makes it possible to measure the velocity of light sources. Indeed, it is commonly used to measure the speed of far away stars. In these cases, the Doppler shift is often characterized by the *red shift number* z , defined as

$$z = \frac{\Delta\lambda}{\lambda} = \frac{f_S}{f_R} - 1 = \sqrt{\frac{c+v}{c-v}} - 1 . \quad (82)$$

Challenge 907

Can you imagine how the number z is determined? Typical values for z found for light sources in the sky range from -0.1 to 3.5 , but higher values, up to more than 5 , have also been found. Can you determine the corresponding speeds? How can they be so high?

In summary, whenever one tries to change the *speed* of light, one only manages to change its *colour*. That is the *Doppler effect*. But the Doppler effect for light is much more important than the Doppler effect for sound. Even if the speed of light were not yet known to be constant, the colour change alone already would *prove* that time is different for observers moving relative to each other. Why? Time is what we read from our watch. In order to determine whether another watch is synchronized with our own one, we look back and forward between the two. In short, we need to use light signals. And a colour change appearing when light moves from one observer to another implies that the watches run differently, and thus means that time is *different* at the two places. Are you able to confirm this conclusion in more detail? Why is the conclusion about time differences not possible when the Doppler effect for sound is used?

Challenge 924

Can one shoot faster than one's shadow?

To realize what Lucky Luke does in Figure 84, both the bullet and the hand have to move faster than the speed of light. To achieve this, certain people use the largest practical amounts

* Johannes Stark (1874–1957), discovered in 1905 the optical Doppler effect in channel rays, and in 1913 the splitting of spectral lines in electrical fields, nowadays called the Stark effect. For both discoveries he received the 1919 Nobel prize for physics. He left his professorship in 1922 and later turned a full-blown national socialist. Member of the NSDAP since 1930, he became known for attacking statements about nature for ideological reasons only, and was thus as a person rightly despised by the academic community.

Challenge 873

** At what speed does a red traffic light appear green?

This is a section of the freely downloadable e-textbook

Motion Mountain

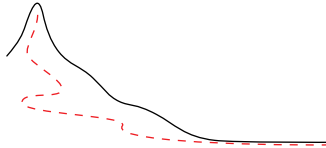

Hiking beyond space and time along the concepts of modern physics

available at
www.motionmountain.org

Copyright © 1997, 1998, 1999, 2000, 2001, 2002 by Christoph Schiller

To the kind reader

In exchange for getting this section for free, I ask you for a short email on some of the following:

- Which page was boring?
- Did you find any mistakes?
- What else were you expecting?
- What was hard to understand?

Of course, any other suggestion is welcome. This section is part of a physics text written over many years. The text lives and grows through the feedback from its readers, who help to improve and to complete it. For a particularly useful contribution (send it in english, italian, dutch, german, spanish, portuguese, or french) you will be mentioned in the foreword of the text, or receive a small reward, or both.

Enjoy!

Christoph Schiller
cs@motionmountain.org

Challenge 890

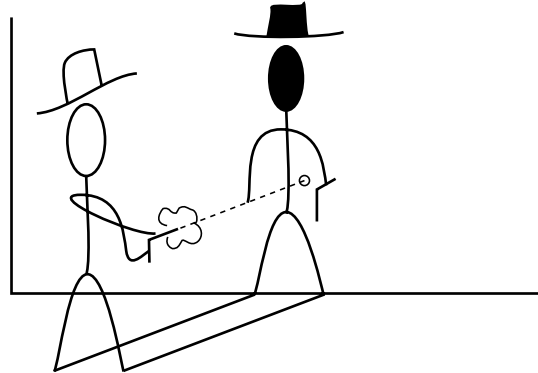

Figure 84 Lucky Luke

of energy possible, taken directly from an electrical power station, accelerate the lightest known objects, namely electrons, and measure the speed that can be achieved. This experiment is carried out daily in particle accelerators such as the Large Electron Positron ring, the LEP, of 27 km circumference located partly in France and partly in Switzerland, near Geneva. In that place, 40 MW of electrical power, the same amount used by a small city, accelerates electrons and positrons to energies of over 16 nJ (100 GeV) each. The result is shown in Figure 85: even with these impressive means it is impossible to make electrons move more rapidly than light. These and many similar observations thus show that there is a *limit* to the velocity of objects. Velocities of bodies (or of radiation) higher than the speed of light do not exist.*

Ref. 176

The people most unhappy with this limit are computer engineers; if the limit were higher, it would be possible to make faster microprocessors and thus faster computers; this would allow, for example, more rapid progress towards the construction of computers that understand and use language.

The observation of a limit speed is in complete contrast to Galilean mechanics. In fact, it means that for velocities near that of light, say about 15 000 km/s or more, the expression $mv^2/2$ is *not* equal to the kinetic energy T of the particle. Such high speeds are rather common: many families have an example in their home. Just determine the speed of electrons inside a television, given that the transformer inside produces 30 kV. Historically, the accuracy of Galilean mechanics was taken for granted for more than three

Challenge 941

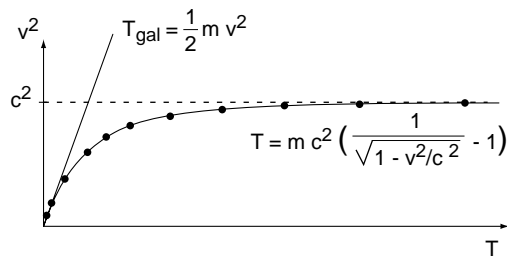

Figure 85 Experimental values (dots) for the electron velocity v as function of kinetic energy T

* There are still people who refuse to accept these results, as well as the ensuing theory of relativity. Every physicist should enjoy the experience, at least once in his life, of discussing with one of these men. (Strangely, no woman has yet been reported as member of this group of people.) This can be done e.g. via the internet, in the sci.physics.relativity news group. See also the <http://www.crank.net> web site. Crackpots are a fascinating lot, especially since they teach the importance of *precision* in language and in reasoning, which they all, without exception, neglect. Encounters with several of them provided the inspiration for this section.

Ref. 177

centuries, so that nobody ever thought of checking it; but when this was finally done, as in Figure 85, it was found to be wrong.

The observation of speed of light as a *limit* speed for objects is easily seen to be a consequence of its *constancy*. Bodies that can be at rest in one frame of reference obviously move more slowly than the maximum velocity (light) in that frame. Now, if something moves more slowly than something else for *one* observer, it does so for all other observers as well. (Trying to imagine a world in which this would not be so is interesting: funny things would happen, such as things interpenetrating each other.) Therefore no object that can be at rest can move faster than the limit speed. But any body which can be at rest does have different speeds for different observers. Conversely, if a phenomenon exists whose speed is the same for all observers, then this speed must necessarily be the limit speed. Among others, one deduces that the maximum speed is the speed of *massless* entities. Light, all the other types of electromagnetic waves and (probably) neutrinos are the only known examples.

Challenge 958

Challenge 975

Ref. 178

A consequence of the existence of a limit velocity is important: velocities cannot simply be added or subtracted, as one is used to in everyday life. If a train is travelling at velocity v_{te} compared to the earth, and somebody throws a stone inside it with velocity v_{st} in the same direction, it is usually assumed as evident that the velocity of the stone relative to the earth is given by $v_{se} = v_{st} + v_{te}$. In fact, measurements show a different result. The combined velocity is given by

$$v_{se} = \frac{v_{st} + v_{te}}{1 + v_{st}v_{te}/c^2} \quad (83)$$

Note that the result is never larger than c . We will deduce the expression in a moment, from reasoning alone.* It has been confirmed by literally all the millions of cases in which it has been checked so far.

Challenge 992

See page 352

The principle of special relativity

The next question to ask is *how* the different time intervals and lengths measured by two observers are related to each other. We start with a situation where neither gravitation nor any other interaction plays a role; in other words, we start with *relativistic kinematics*.

If an undisturbed body travels along a straight line with a constant velocity, or if it stays at rest, one calls the observer making this observation *inertial*, and the coordinates used by the observer an *inertial frame of reference*. Examples of inertial observers (or frames) are – for *two* dimensions – those moving on a frictionless ice surface or on the floor inside a smoothly running train or ship; a full example – for all *three* spatial dimensions – is a cosmonaut in an Apollo capsule while travelling between the moon and the earth, as long as the engine is switched off. Inertial observers in three dimensions might also be called *free-floating* observers. They are thus not so common.

Special relativity is built on a simple principle:

▷ *The maximum speed of energy transport is the same for all free floating observers.*

Or:

▷ *The speed of light is the same for all inertial observers.*

Ref. 180 * One can also deduce the Lorentz transformation from this expression.

Or, as we will show below, the equivalent:

▷ The speed v of a physical system is bound by

$$v \leq c \tag{84}$$

for all inertial observers, where c is the speed of light.

Ref. 181 This experimental statement was checked with high precision by Michelson and Morely* in the years from 1887 onwards. It has been confirmed in all subsequent experiments. Therefore the following conclusions can be drawn from it, using various (weak) implicit assumptions which will become clear during the rest of our ascent of Motion Mountain:

- In a closed free-floating room, there is no way to tell the speed of the room.
- There is no absolute rest; rest is an observer-dependent concept.
- All inertial observers are equivalent: they describe the world with the same equations.

This statement was called the *principle of relativity* by Henri Poincaré.

- Any two inertial observers move with constant velocity relative to each other. (Are you able to show this?)

Challenge 1009

Historically, it was the equivalence of all inertial observers which used to be called the principle of relativity. Nowadays this habit is changing, though slowly, mainly because the habit is connected to Poincaré and to Einstein himself. The *essence* of relativity however is the existence of a limit speed.

But let us continue with the original topic of this section. To see how length and space intervals change from one observer to the other, assume that two observers, a Roman one using coordinates x, y, z and t , and a Greek one using coordinates ξ, υ, ζ and τ ,** move with velocity \mathbf{v} relative to each other. The axes are chosen in such a way that the velocity points in the x -direction. We start by noting that the constancy of the speed of light in any direction for any two observers means that

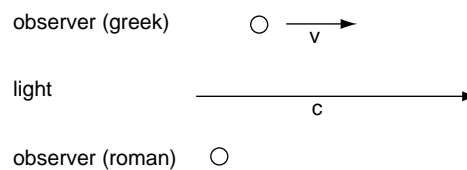

Figure 86 Two inertial observers, using coordinates (t, x) and (τ, ξ) , and a beam of light

$$(cdt)^2 - (dx)^2 - (dy)^2 - (dz)^2 = (cd\tau)^2 - (d\xi)^2 - (d\upsilon)^2 - (d\zeta)^2 \quad . \tag{85}$$

Assume also that a flash lamp at rest for the Greek observer, thus with $d\xi = 0$, produces two flashes spaced by an interval $d\tau$. For the Roman observer, the flash lamp moves, so that $dx = vdt$. Inserting this into the previous expression, and assuming linearity and speed direction independence for the general case, we find that intervals are related by

Challenge 1026

* Albert Abraham Michelson (1852, Strelno–1931, Pasadena) Prussian–Polish–US-American physicist, Nobel prize in physics in 1907. Michelson called the set-up he devised an *interferometer*, a term still in use today. Edward William Morely (1838–1923), US-American chemist, was Michelson’s friend and longtime collaborator. ** They are read as ‘xi’, ‘upsilon’, ‘zeta’, and ‘tau’. The names, correspondences and pronunciations of all Greek letters are explained in Appendix A.

$$\begin{aligned}
 dt &= \gamma(d\tau + vd\xi/c^2) = \frac{d\tau + vd\xi/c^2}{\sqrt{1 - v^2/c^2}} \quad \text{with } v = dx/dt \\
 dx &= \gamma(d\xi + vd\tau) = \frac{d\xi + vd\tau}{\sqrt{1 - v^2/c^2}} \\
 dy &= dv \\
 dz &= d\zeta \quad . \quad (86)
 \end{aligned}$$

These expressions describe how length and time intervals measured by different observers are related. At relative speeds v that are small compared to the velocity of light, such as in everyday life, the time intervals are essentially equal; the *stretch factor* or *relativistic correction* or *relativistic contraction* γ is then equal to 1 for all practical purposes. However, for velocities *near* that of light the measurements of the two observers give different values. In these cases, space and time *mix*, as shown in Figure 87.

The expressions are also strange in another respect. When two observers look at each other, each of them claims to measure shorter intervals than the other. In other words, special relativity shows that the grass on the other side of the fence is always *shorter* – when one rides along the fence on a bicycle. We explore this bizarre result in more detail shortly.

Challenge 1043

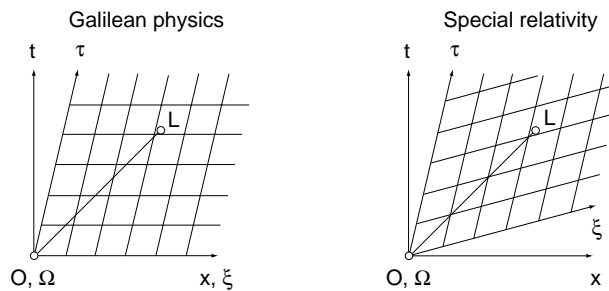

Figure 87 Space-time diagrams for light seen from two different observers

The stretch factor γ is equal to 1 in everyday life and for most practical purposes. The largest value humans have ever achieved is about $2 \cdot 10^5$; the largest observed value in nature is about 10^{12} . Can you imagine their occurrences?

Challenge 1060

Once we know how space and time *intervals* change, we can easily deduce how *coordinates* change. Figures 86 and 87 show that the x coordinate of an event L is the sum of two intervals: the ξ coordinate and the length of the distance between the two origins. In other words, we have

$$\xi = \gamma(x - vt) \quad \text{and} \quad v = \frac{dx}{dt} \quad . \quad (87)$$

Using the invariance of the space-time interval, we get

$$\tau = \gamma(t - xv/c^2) \quad . \quad (88)$$

Henri Poincaré called these two relations the *Lorentz transformations of space and time* after their discoverer, the Dutch physicist Hendrik Antoon Lorentz.* In one of the most

* Hendrik Antoon Lorentz (Arnhem, 1853–Haarlem, 1928) was, together with Boltzmann and Kelvin, the most important physicist of his time. He was the first to understand, long before quantum theory confirmed the idea,

Ref. 182 beautiful discoveries of physics, in 1892 and 1904, Lorentz deduced these relations from the equations of electrodynamics, which had contained them, waiting to be discovered, since 1865.* In that year James Clerk Maxwell had published them in order to describe everything electric and magnetic.

The Lorentz transformation describes the change of viewpoint from one inertial frame to a second, moving one. This change is called a (Lorentz) *boost*.

The formulas for the boost form the basis of the theories of relativity, both the special and the general one. In fact, the mathematics of special relativity will not get more difficult than that; if you know what a square root is, you can study special relativity in all its beauty.

Ref. 179 Many alternative formulas for boosts have been explored, such as expressions in which instead of the relative velocity also the relative acceleration of the two observers is included. However, all had to be discarded when compared to experimental results. But before we have a look at such experiments, we continue with a few logical deductions from the boost relations.

What is space-time?

The Lorentz transformations tell something important: space and time are two aspects of the same ‘stuff’, they are two aspects of the same basic entity. They mix in different ways for different observers. This fact is commonly expressed by stating that time is the *fourth dimension*. This makes sense because the common entity, called *space-time*, can be defined as the set of all possible events, because events are described by four coordinates in time and space, and because the set of all events behaves like a manifold. (Can you confirm this?) In the theory of special relativity, the space-time manifold is characterized by a simple property: the *space-time interval* di between two nearby events, defined as

$$di^2 = c^2 dt^2 - dx^2 - dy^2 - dz^2 = c^2 dt^2 \left(1 - \frac{v^2}{c^2}\right) \quad , \quad (89)$$

is *independent* of the (inertial) observer. Such a space-time is also called Minkowski space-time, after the German physicist Hermann Minkowski (1864–1909), the prematurely passed away teacher of Albert Einstein; he was the first physicist, in 1904, to define the concept and to understand its usefulness and importance.

The space-time interval of equation (89) has a simple interpretation. It is the time measured by an observer moving between from event (t, x) to event $(t + dt, x + dx)$, the so-called *proper time*, multiplied by c^2 . One could simply call it wristwatch time.

How does Minkowski space-time differ from Galilean space-time, the combination of everyday space and time? Both space-times are manifolds, i.e. continuum sets of points; both have one temporal and three spatial dimensions, and both manifolds are infinite, i.e. open, with the topology of the punctured sphere. (Can you confirm this?) Both man-

that almost all material properties are due to interacting electrons. He showed this in particular for the dispersion of light, for the Zeeman effect, for the Hall effect, for the Faraday effect, and many others. He understood that Maxwell’s equations for the vacuum describe matter as well, as long as charged point particles are included. He also gave the correct description of the Lorentz force. Outside physics, he was active in the internationalization of scientific collaborations.

* The Irishman George F. Fitzgerald had had already discovered the Lorentz transformations in 1889, but had, in contrast to Lorentz, not continued his research in the field.

ifolds are flat, i.e. free of curvature. In both cases, space is what one measures with a metre rule or with a light ray, and time is what one reads from a clock. In both cases, space-time is fundamental; it is and remains the *background* and the *container* of things and events. We *live* in a Minkowski space-time, so to speak. Minkowski space-time exists independently of things. And even though coordinate systems can be different from observer to observer, the underlying entity, space-time, is still *unique*, even though space and time by themselves are not.

The central difference, in fact the only one, is that Minkowski space-time, in contrast to the Galilean case, *mixes* space and time, and does so differently for different observers, as shown in Figure 87.

Relativity thus forces us to describe motion with space-time. That is interesting, because in space-time, *motion does not exist*. Motion exists only in space. In space-time, nothing moves. For each point particle, space-time contains a world-line. In other words, instead of asking why motion exists, we can equivalently ask why space-time is criss-crossed by world-lines. However, we are still far from answering either question.

Can we travel to the past? – Time and causality

Given that time is different for different observers, does time nevertheless order events in sequences? The answer of relativity is a clear yes and no. Certain sets of events are not in any given sequence; others sets are. This is best seen in a space-time diagram.

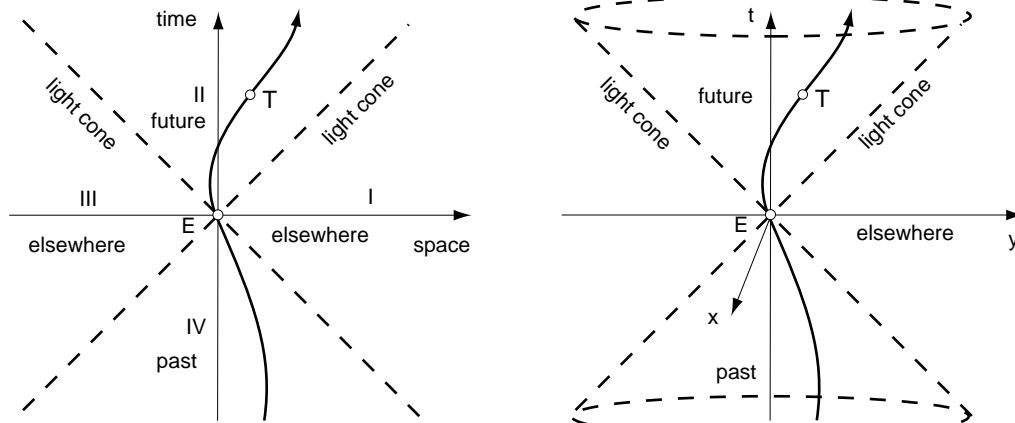

Figure 88 A space-time diagram of an object T seen from an inertial observer O in the case of one and of two spatial dimensions

Sequences of events can clearly be defined if one event is the cause of another. But this can only be the case if energy or signals travel from one event to another at speeds up to the speed of light. Figure 88 shows that event E at the origin of the coordinate system can only be influenced by events in quadrant IV (the *past light cone*, when all space dimensions are included), and itself can influence only events in quadrant II (the *future light cone*). Events in quadrants I and III do not influence, nor are they influenced by event E. In other words, the light cone defines the boundary between events that *can* be ordered with respect to their origin – namely those inside the cones – and those that *cannot* – those outside the

cones, happening elsewhere for all observers. In short, time orders events only *partially*. For example, for two events that are not causally connected, their simultaneity and their temporal order depends on the observer!

In particular, the past light cone gives the complete set of events that can influence what happens at the origin. One says that the origin is *causally connected* only to the past light cone. This is a consequence of the fact that any influence involves

transport of energy, and thus cannot travel faster than the speed of light. Note that causal connection is an invariant concept: all observers agree on whether it applies to two given events or not. Are you able to confirm this?

Challenge 1111

A vector inside the light cone is called *timelike*; one on the light cone is called *lightlike*, and one outside the cone is called *spacelike*. For example, the *world-line* of an observer, i.e. the set of all events that make up its history, consists of timelike events only. In fact, time is the fourth dimension; it expands space to space-time and thus 'completes' space-time. There is not much more to know about the fourth dimension, or about thinking in four dimensions.

Special relativity thus teaches us that time can be defined *only* because light cones exist. If transport of energy at speeds faster than that of light did exist, time could not be defined. Causality, i.e. the possibility of (partially) ordering events for all observers, is thus due to the existence of a maximal velocity.

If the speed of light could be surpassed in some way, the future could influence the past. Are you able to confirm this? In such situations one would speak of *acausal* effects. However, there is an everyday experience which tells that the speed of light is indeed maximal: our memory. If the future could influence the past, we would also be able to *remember* the future. To put it in another way, if the future could influence the past, the second principle of thermodynamics would not be valid, and then our memory would not work.* No other data from everyday life or from experiments provides any evidence that the future can influence the past. In other words, *time travel to the past is impossible*. How the situation changes in quantum theory will be revealed later on. Interestingly, time travel to the future *is* possible, as we will see shortly.

Challenge 7

Ref. 184

Curiosities of special relativity

Faster than light: how far can we travel?

How far away from earth can we travel, given that the trip should not last more than a lifetime, say 80 years, and given that we are allowed to use a rocket whose speed can approach the speed of light as closely as desired? Given the time t we are prepared to spend in a rocket, given the speed v of the rocket and assuming optimistically that it can accelerate and decelerate in a negligible amount of time, the distance d we can move away is given by

Challenge 24

$$d = \frac{vt}{\sqrt{1 - v^2/c^2}} \quad . \quad (90)$$

* Another related result is slowly becoming common knowledge. Even if space-time had a non-trivial shape, such as a cylindrical topology, one still would not be able to travel into the past, in contrast to what many science fiction novels suggest. This is made clear by Stephen Blau in a recent pedagogical paper.

Ref. 185

The distance d is larger than ct already for $v > 0.71c$, and, if v is chosen large enough, it increases beyond all bounds! In other words, relativity itself does *not* limit the distance we can travel, not even that covered in a single second. We could, in principle, roam the entire universe in less than a second. In situations such as these it makes sense to introduce the concept of *proper velocity* w , defined as

$$w = d/t = \frac{v}{\sqrt{1 - v^2/c^2}} = \gamma v \quad . \quad (91)$$

As just shown, proper velocity is *not* limited by the speed of light; in fact the proper velocity of light itself is infinite.*

Synchronization and aging: can a mother stay younger than her own daughter? – Time travel to the future

In the theory of special relativity time is different for different observers moving relative to each other. This implies that we have to be careful how to synchronize clocks that are far apart, even if they are at rest with respect to each other in an inertial reference frame. For example, if we have two identical watches showing the same time, and if we carry one of the two for a walk and back, they will show different times afterwards. This experiment has actually been performed several times and has fully confirmed the prediction of special relativity. The time difference for a person or a watch in a plane going around the earth once, at about 900 km/h, is of the order of 100 ns – not very noticeable in everyday life. In fact, the delay is easily calculated from the expression

Ref. 187, 188

$$\frac{t}{t'} = \gamma \quad . \quad (93)$$

Also human bodies are clocks; they show the elapsed time, usually called *age*, by various changes in their shape, weight, hair colour, etc. If a person goes on a long and fast trip, on her return she will have aged *less* than a second person who stayed at her (inertial) home. Special relativity thus confirms, in a surprising fashion, the well-known result that those who travel a lot remain younger.

This can also be seen as a confirmation of the possibility of time travel to the future. With the help of a fast rocket that comes back to its starting point, we can arrive at local times that we would never have reached within our lifetime. Alas, as has just been said, we can *never* return to the past.**

In short, the question in the title of this section has a positive answer. Can you explain this to a friend, using a space-time diagram and the expression for proper time τ ? This famous

Challenge 58

Challenge 41

* Using proper velocity, the relation given in (83) for the superposition of two velocities $\mathbf{w}_a = \gamma_a \mathbf{v}_a$ and $\mathbf{w}_b = \gamma_b \mathbf{v}_b$ simplifies to

$$w_{s\parallel} = \gamma_a \gamma_b (v_a + v_{b\parallel}) \quad \text{and} \quad w_{s\perp} = w_{b\perp} \quad , \quad (92)$$

where the signs \parallel and \perp mean the components in direction of motion and that perpendicular to \mathbf{v}_a , respectively.

Ref. 186

One can in fact write all of special relativity using ‘proper’ quantities, even though this is not done in this text.

Ref. 189

** There are even special books on time travel, such as the well researched text by Nahin. Note that the concept of time travel has to be clearly defined; otherwise one gets into the situation of the clerk who called his office chair a time machine, as sitting on it allows him to get to the future.

Ref. 190 result, usually called the *clock paradox* or the *twin paradox*, has also been confirmed in many experiments. We give a simple example below.

Challenge 75 We can also conclude that we cannot synchronize clocks simply by walking, clock in hand, from one place to the next. The correct way to do this is to exchange light signals. Can you describe how?

In summary, only with a clear definition of synchronization can we call two distant events simultaneous. In addition, special relativity shows that simultaneity depends on the observer. This is confirmed by all experiments performed so far.

Length contraction

Can a rapid snowboarder fall into a hole that is a bit shorter than his board? Imagine him boarding so fast that the length contraction factor $\gamma = d/d'$ is 4.* For an observer on the ground, the snowboard is four times shorter, and when it passes over the hole, it will fall into it. However, for the boarder, it is the hole which is four times shorter; it seems that the snowboard cannot fall into it.

Ref. 191 More careful analysis shows that, in contrast to the observation of hole digger, the snowboarder does not experience the board shape as fixed; while passing over a hole, the boarder observes that the board takes on a parabolic shape and falls into the hole, as shown in Figure 89. Can you confirm this? In other words, shape is *not* an observer invariant concept. (However, rigidity is such a concept, if defined properly; can you confirm this?)

Challenge 109

Challenge 126

Ref. 192 The situation becomes more interesting in the case that the snowboard is replaced by a conductive bar and makes electrical contact between the two sides of the hole. As gravity is not needed, the whole arrangement is simplified by turning it on its side, as in Figure 90. Are you able to find out whether a lamp connected in series stays lit when the glider moves along the contacts? Do you get the same result for all observers? And what happens when the glider is longer than the detour? (Warning: this problem gives rise to *heated* debates!)

Challenge 143

Ref. 193 Another example of the phenomenon of *length contraction* appears when two objects, say two cars, are connected over a distance d by a straight rope. Imagine that both are at rest at time $t = 0$ and are accelerated together in exactly the same way. The observer at rest will maintain that the two cars remain the same distance apart. On the other hand, the rope needs to span a distance $d' = d/\sqrt{1 - v^2/c^2}$, which has to expand when the two cars are moving. In other words, the rope will break. Is this prediction confirmed by observers on each of the two cars?

Challenge 160

Challenge 92 * Even the earth contracts in its direction of motion around the sun. Is the value measurable?

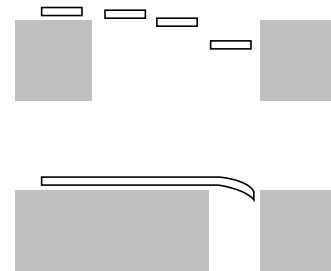

Figure 89 The observations of the trap digger and of the snowboarder

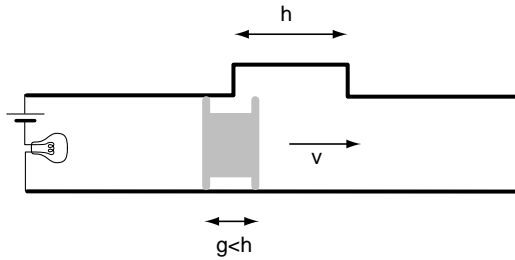

Figure 90 Does the conducting glider keep the lamp lit at large speeds?

Which is the best seat in a bus?

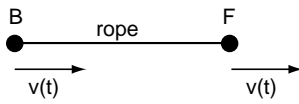

Figure 91 What happens to the rope?

The last example provides another surprise. Imagine two twins inside the two identically accelerated cars, starting from standstill at time $t = 0$, as described by an observer at rest with respect to both of them. Both cars contain the same amount of fuel. (Let's forget the rope now.) One easily finds that the acceleration of the two twins stops at the same time in the frame of the outside observer, that the distance between the cars has

Ref. 193

remained the same all along for the outside observer, and that the two cars continue rolling with an identical constant velocity, as long as friction is negligible. If we call the events at which the front car and back car engines switch off f and b , their time coordinates in the outside frame are related simply by $t_f = t_b$. By using the Lorentz transformations you can deduce for the frame of the freely rolling twins the relation

Challenge 177

$$t_b = \gamma \Delta x v / c^2 + t_f \quad , \quad (94)$$

which means that the front twin has aged *more* than the back twin. Therefore it seems that if we want to avoid grey hair as much as possible, we should always sit in the back of a bus or train when travelling. Is the conclusion correct? And is it correct to deduce that people on high mountains age faster than people in valleys?

Challenge 194

Challenge 211

How fast can one walk?

To walk means to move the feet in such a way that at least one of the two feet is on the ground at any time. This is one of the rules athletes have to follow in Olympic walking competitions, and they are disqualified if they break it. A certain student athlete was thinking about the theoretical maximum speed he could achieve in the Olympics. The ideal would be that each foot accelerates instantly to (almost) the speed of light. The highest walking speed can be achieved by taking the second foot off the ground at exactly the same instant at which the first is put down. In the beginning, by 'same instant' the student meant 'as seen by a competition judge at rest with respect to earth'. The motion of the feet is shown in the left of Figure 92; it gives a limit speed for walking of half the speed of light. But then the student noticed that a *moving* judge will see both feet off the ground and thus disqualify the

athlete for running. To avoid disqualification from *any* judge, the second foot has to wait for a light signal from the first. The limit speed for Olympic walking thus is only one third of the speed of light.

Ref. 194

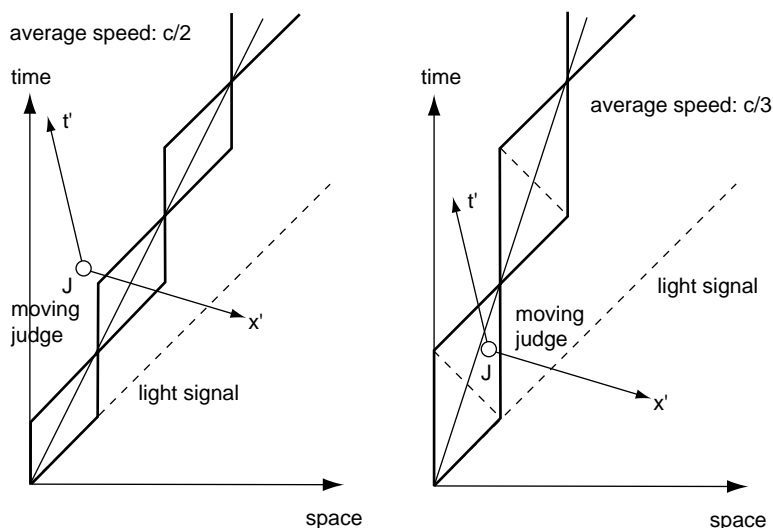

Figure 92 For the athlete on the left, the judge moving in the opposite direction sees both feet off the ground at certain times, but not for the athlete on the right

Is the speed of shadow greater than the speed of light?

Contrary to what is often implied, motion faster than light does exist and is even rather common. Special relativity only constrains the motion of mass and energy. However, non-material points, non-energy transporting features and images *can* move faster than light. We give a few simple examples. Note that we are not talking about *proper* velocity, which in these cases cannot be defined anyway. (Why?)

See page 183
Challenge 228

Neither are we talking of the situation where a particle moves faster than the velocity of light in matter, but slower than the velocity of light in vacuum. This situation gives rise to the so-called *Cerenkov radiation* if the particle is charged. It corresponds to the v-shaped wave created by a motor boat on the sea or the cone-shaped shock wave around an aeroplane moving faster than the speed of sound. Cerenkov radiation is regularly observed; for example it is the cause of the blue glow of the water in nuclear reactors. Incidentally, the speed of light in matter can be quite low; in the centre of the sun, the speed of light is estimated to be only around 10 km/year, and in the laboratory, for some materials, it has been found to be 0.3 m/s.

Ref. 195, 19

In contrast, the following examples show velocities that are genuinely faster than the externally measured velocity of light in vacuum. An example is the point marked X in Figure 93, the point at which scissors cut paper. If the scissors are closed rapidly enough, the point moves faster than light. Similar geometries can also be found in every window frame, and in fact in any device that has twisting parts.

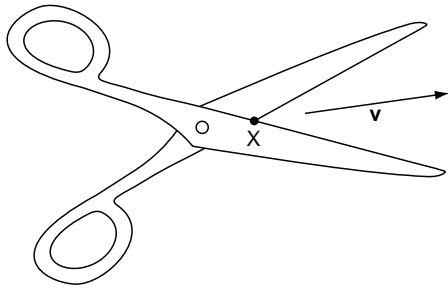

Figure 93 A simple example of motion that is faster than light

Another example of superluminal motion is the speed with which a music record – remember LPs? – disappears into its sleeve, as shown in Figure 94.

Finally, a standard example is the motion of a spot of light produced by shining a laser beam onto the moon. If one moves the laser, the spot can easily move faster than light. The same happens for the light spot on the screen of an oscilloscope when a signal of sufficiently high frequency is fed to the input.

All these are typical examples of the *speed of shadows*, sometimes also called the *speed of darkness*. Both shadows and darkness can indeed move faster than light. In fact, there is no limit to their speed. Can you find another example?

Challenge 245

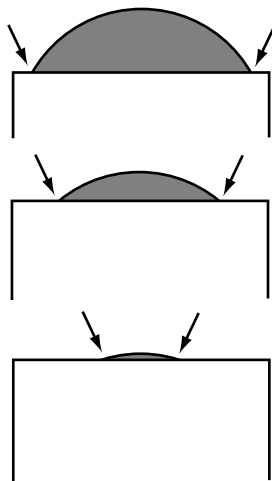

Figure 94 Another example of faster than light motion

In addition, there is an ever-increasing number of experimental set-ups in which the phase velocity or even the group velocity of light is higher than c . They regularly make headlines in the newspapers, usually of the type ‘light moves faster than light’. This surprising result is discussed in more detail later on.

See page 374

For a different example, imagine standing at the exit of a tunnel of length l . We see a car, whose speed we know to be v , entering the other end of the tunnel and driving towards us. We know that it entered the tunnel because the car is no longer in the sun or because its headlights were switched on at that moment. At what time t does it drive past us? Simple reasoning shows that t is given by

$$t = l/v - l/c \quad . \quad (95)$$

In other words, the approaching car seems to have a velocity v_{appr} of

$$v_{\text{appr}} = \frac{l}{t} = \frac{vc}{(c - v)} \quad , \quad (96)$$

which is higher than c for any car velocity v higher than $c/2$. For cars this does not happen too often, but astronomers know a type of bright object in the sky called a *quasar* (a contraction of ‘quasi-stellar’), which sometimes emits high-speed gas jets. If the emission is in or near the direction to the earth, the apparent speed is higher than c ; such situations are now regularly observed with telescopes.

Ref. 196

Note that to a second observer at the *entrance* of the tunnel, the apparent speed of the car *moving away* is given by

$$v_{\text{leav}} = \frac{vc}{(c + v)} \quad , \quad (97)$$

which is *never* higher than $c/2$. In other words, objects are never seen departing with more than half the speed of light.

The story has a final twist. We have just seen that motion faster than light can be observed in several ways. But could an *object* moving faster than light be observed at all? Surprisingly, the answer is no, at least not in the common sense of the expression. First of all, since such an imaginary object, usually called a *tachyon*, moves faster than light, we can never see it approaching. If at all, tachyons can only be seen departing.

Seeing a tachyon is very similar to hearing a supersonic jet. Only *after* a tachyon has passed nearby, assuming that it is visible in daylight, could we notice it. We would first see a flash of light, corresponding to the bang of a plane passing with supersonic speed. Then we would see *two* images of the tachyon, appearing somewhere in space and departing in opposite directions, as can be deduced from Figure 95. Even if one of the two images were coming nearer, it would be getting fainter and smaller. This is, to say the least, rather unusual behaviour. Moreover, if you wanted to look at a tachyon at night, illuminating it with a torch, you would have to

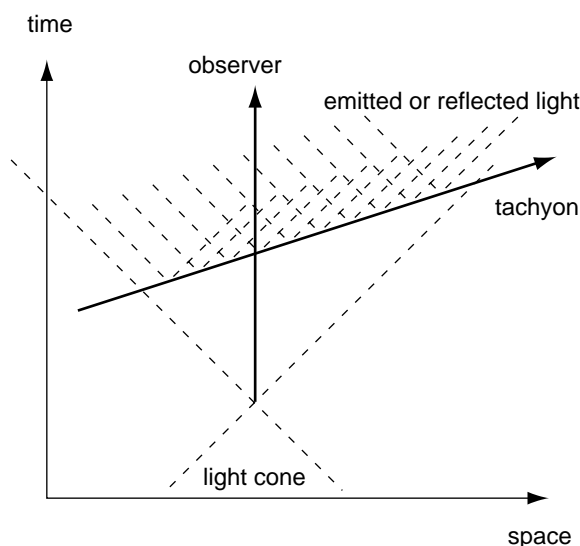

Figure 95 Hypothetical space-time diagram for tachyon observation

Challenge 262

Ref. 197

are you able to deduce this? Nobody has ever seen such phenomena; tachyons do not exist. Tachyons would be strange objects: they would have imaginary mass, they would accelerate when they lose energy, and a zero-energy tachyon would be infinitely fast. But no object with these properties has ever been observed. Worse, as we just saw, tachyons would seem to appear from nothing, defying laws of conservation; and note that, since tachyons cannot be seen in the usual sense, they cannot be touched either, since both processes are due to electromagnetic interactions, as we will see later in our ascent of Motion Mountain. Tachyons therefore cannot be objects in the usual sense. In the second part of our adventure we will show that quantum theory actually *rules out* the existence of (free) tachyons. However, it also requires the existence of virtual tachyons, as we will discover.

But the best is still to come. Not only is it impossible to see approaching tachyons; it follows from equation (97) that departing ones seem to move with a velocity *lower* than the speed of light. In other words, we just found that if we ever see something move faster than light, it can be anything *but* a tachyon!

Parallel to parallel is not parallel – Thomas rotation

Relativity has strange consequences indeed. Even though any two observers can keep a stick parallel to the stick of another, even if they are moving with respect to each other, something strange results. A chain of sticks for which any two adjacent ones are parallel to each other

will *not* ensure that the first and the last sticks are parallel. In particular, this is *never* the case if the motions of the various observers are in different directions, as is the case when the velocity vectors form a loop.

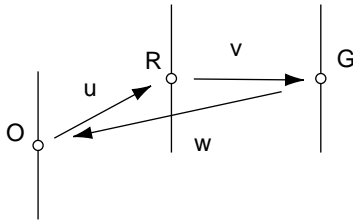

Figure 96 If O's stick is parallel to R's, and R's is parallel to G's, then O's stick and G's stick are not

This surprising result is purely relativistic, and thus occurs *only* in the case of speeds comparable to that of light. It results from the fact that in general, concatenations of pure boosts do not give a pure boost, but a boost and a rotation.

Ref. 198

For example, if we walk with a stick in a fast circle, always keeping the stick parallel to the direction it had just before, at the end of the circle the stick will have an angle with respect to the original direction. Similarly, the axis of a rotating body circling a second body will *not* be pointing in the same direction after one turn, if the orbital velocity is comparable to that of light. This effect is called *Thomas precession*, after Llewellyn Thomas, who discovered it in 1925, a full 20 years after the birth of special relativity. It had escaped the attention of dozens of other famous physicists. Thomas precession is important in the inner working of atoms and we will return to it in that section of our adventure.

A never-ending story: temperature and relativity

Not everything is settled in special relativity. Do you want a problem to solve? Just deduce how temperature changes from one frame of reference to another, and publish the result. Just have a try. There are many opinions on the matter. True, Albert Einstein and Wolfgang Pauli agreed that the temperature T seen by a moving observer is related to the temperature T_0 measured by the observer at rest with respect to the bath via

Challenge 279

$$T = T_0 \sqrt{1 - v^2/c^2} \quad , \quad (98)$$

thus always yielding lower values. But others maintain that T and T_0 should be interchanged in this expression. Even powers other than the simple square root have been proposed.

Ref. 199

The origin of these discrepancies is simple: temperature is only defined for equilibrium situations, i.e. for baths. But a bath for one observer is usually not a bath for the other; for low speeds, a moving observer sees *almost* a bath; but at higher speeds the issue becomes tricky. The resulting temperature change may even depend on the energy range measured. So far, there do not seem to be any experimental observations that would allow the issue to be settled. Realizing such a measurement is a challenge for future experiments.

Relativistic mechanics

As the speed of light is constant and velocities do not add up, we need to rethink the definition of mass, as well as the definitions of momentum and energy.

Mass in relativity

In Galilean physics, the mass ratio between two bodies was defined using collisions; it was given by the negative inverse of the velocity change ratio See page 60

$$\frac{m_2}{m_1} = -\frac{\Delta v_1}{\Delta v_2} . \tag{99}$$

Challenge 296

However, experiments show that the expression changes for speeds near that of light. In fact, thinking alone can show this; are you able to do so?

The solution to this issue was found by Albert Einstein. He discovered that in collisions, the two Galilean conservation theorems $\sum_i m_i v_i = \text{const}$ and $\sum_i m_i = \text{const}$ had to be changed into

$$\sum_i \gamma_i m_i v_i = \text{const} \tag{100}$$

and

$$\sum_i \gamma_i m_i = \text{const} . \tag{101}$$

Challenge 313

These expressions, which are correct throughout the rest of our ascent of Motion Mountain, imply, among other things, that teleportation is *not* possible in nature. (Can you confirm this?) Obviously, in order to recover Galilean physics, the relativistic correction factors γ_i have to be equal to 1 for everyday life velocities, and have to differ noticeably from that value only for velocities near the speed of light. Even if we did not know the value of the relativistic correction,

Challenge 330

we could find it by a simple deduction from the collision shown in Figure 97. In the first frame of reference we have $\gamma_1 m v = \gamma_2 M V$ and $\gamma_1 m + m = \gamma_2 M$. From the observations of the second frame of reference we deduce that V composed with V gives v , in other words

$$v = \frac{2V}{1 + V^2/c^2} . \tag{102}$$

When these equations are combined, the relativistic correction γ is found to depend on the magnitude of the velocity v through

$$\gamma_v = \frac{1}{\sqrt{1 - v^2/c^2}} . \tag{103}$$

With this expression, and a generalization of the situation of Galilean physics, the *mass* ratio between two colliding particles is defined as the ratio

$$\frac{m_1}{m_2} = -\frac{\Delta(\gamma_2 v_2)}{\Delta(\gamma_1 v_1)} . \tag{104}$$

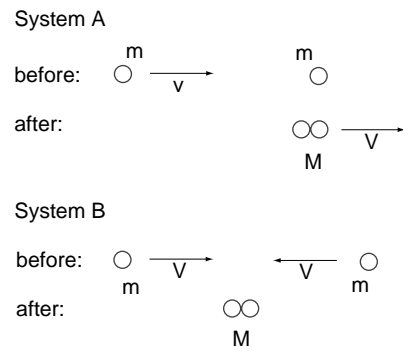

Figure 97 An inelastic collision of two identical particles seen from two different inertial frames of reference

(We do not give the generalized mass definition mentioned in Galilean mechanics and based on acceleration ratios, because it contains some subtleties that we will discover shortly.) The correction factors γ_i ensure that the mass defined by this equation is the same as the one defined in Galilean mechanics, and that it is the same for all types of collision a body may have.* In this way, the concept of mass remains a number characterizing the difficulty of accelerating a body, and it can still be used for *systems* of bodies as well.

Following the example of Galilean physics, we call the quantity

$$\mathbf{p} = \gamma m \mathbf{v} \tag{105}$$

the (*linear*) *relativistic (three-) momentum* of a particle. Again, the total momentum is a *conserved* quantity for any system not subjected to external influences, and this conservation is a direct consequence of the way mass is defined.

For low speeds, or $\gamma \approx 1$, the value is the same as that of Galilean physics. But for high speed, momentum increases faster than velocity, as it tends to infinity when approaching light speed. Momentum is thus not proportional to velocity any more.

Why relativistic pool is more difficult

A well-known property of collisions between a moving sphere or particle and a resting one of the *same mass* is important when playing pool and similar games, such as snooker or billiards.

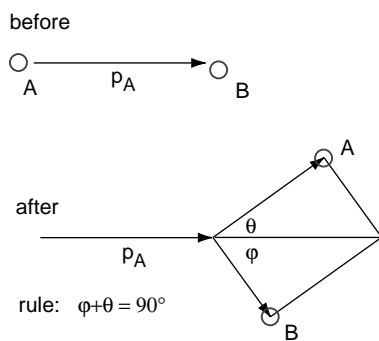

Figure 98 A useful rule for playing non-relativistic pool

After the collision, the two spheres will depart at a *right angle* from each other. However, experiments show that this rule is *not* realized for relativistic collisions. Indeed, using the conservation of momentum, you can find with a bit of dexterity that

$$\tan \theta \tan \phi = \frac{2}{\gamma + 1} \tag{106}$$

Challenge 364

In other words, the sum $\theta + \phi$ is *smaller* than a right angle in the relativistic case. Relativistic speeds thus completely change the game of pool. Every accelerator physicist knows this, because for electrons or protons such angles can be easily deduced from photographs taken with cloud chambers, which show the tracks of

particles when they fly through them. They all confirm the above expression. If relativity were wrong, most of these detectors would not work, as they would miss most of the particles after the collision, as shown in Figure 99.

Mass is concentrated energy

Let us go back to the simple collinear collision of Figure 97. What is the mass M of the final system? A somewhat boring calculation shows that

Challenge 381

Challenge 347 * The results below also show that $\gamma = 1 + T/mc^2$, where T is the kinetic energy of a particle.

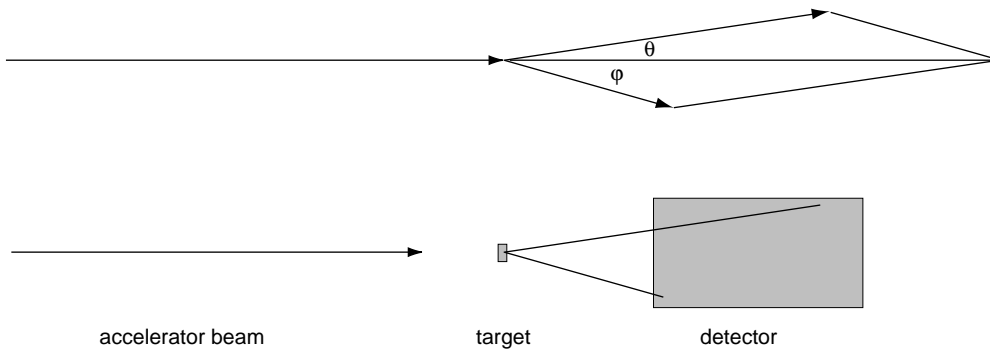

Figure 99 The dimensions of detectors in particle accelerators are based on the relativistic pool angle rule

$$M/m = \sqrt{2(1 + \gamma_V)} > 2 \quad . \quad (107)$$

In other words, the mass of the final system is *larger* than the sum of the two original masses. In contrast to Galilean mechanics, the sum of all masses in a system is *not* a conserved quantity. Only the sum $\sum_i \gamma_i m_i$ of the corrected masses is conserved.

The solution of this puzzle was also given by Einstein. In one of the magic moments of physics history he saw that everything fell into place if, for the *energy* of an object of mass m and velocity v , he used the expression

$$E = \gamma mc^2 \quad , \quad (108)$$

applying it both to the total system and to each component. The conservation of the corrected mass can then be read as the conservation of energy, simply without the factor c^2 . In the example of the two identical masses sticking to each other, the two particles are thus each described by mass and energy, and the resulting system has an energy E given by the sum of the energies of the two particles. In particular, it follows that the energy E_0 of a body *at rest* and its mass m are related by

$$E_0 = mc^2 \quad (109)$$

which is perhaps the most beautiful and famous discovery of modern physics. Since the value for c^2 is so large, we can say that *mass is concentrated energy*. The kinetic energy T is then given by

$$T = \gamma mc^2 - mc^2 = \frac{1}{2}mv^2 + \frac{1 \cdot 3}{2 \cdot 4}m \frac{v^4}{c^2} + \frac{1 \cdot 3 \cdot 5}{2 \cdot 4 \cdot 6} \frac{v^6}{c^4} + \dots \quad (110)$$

which reduces to the Galilean value only for low speeds. In other words, special relativity says that every mass has energy, and that every form of energy in a system has mass. Increasing the energy of a system increases its mass, and decreasing the energy content decreases the mass. In short, if a bomb explodes inside a closed box, the mass, weight and momentum of the box are the same before and after the explosion, but the combined mass of the debris inside the box will be *smaller* than before. All bombs – not only nuclear ones – thus take their energy from a reduction in mass.

By the way, we should be careful to distinguish the transformation of *mass* into energy from the transformation of *matter* into energy. The latter is much more rare. Can you give some examples?

Challenge 398

The mass–energy relation (108) means the death of many science fiction fantasies. It implies that there are *no* undiscovered sources of energy on or near earth. If such sources existed, they would be measurable through their mass. Many experiments have looked for, and are still looking for, such effects with a negative result. Free energy is unavailable in nature.*

The mass–energy relation $m = E_0/c^2$ also implies that one needs about 90 thousand million kJ (or 21 thousand million kcal) to increase one’s weight by one single gram – even though diet experts have slightly different opinions on this matter. In fact, humans do get their everyday energy from the material they eat, drink and breathe by reducing its combined weight before expelling it again. However, this *chemical mass defect* appearing when fuel is burned cannot yet be measured by weighing the materials before and after the reaction; the difference is too small, because of the large conversion factor involved. Indeed, for any chemical reaction, bond energies are about 1 aJ (6 eV) per bond; this gives a weight change of the order of one part in 10^{10} , too small to be measured by weighing people or mass differences between food and excrement. Therefore, for chemical processes mass can be approximated to be constant, as is indeed done in Galilean physics and in everyday life.

However, modern methods of mass measurement of *single molecules* have made it possible to measure the chemical mass defect through comparisons of the mass of a single molecule with that of its constituent atoms. David Pritchard’s group has developed Penning traps that allow masses to be determined from the measurement of frequencies; the attainable precision of these cyclotron resonance experiments is sufficient to confirm $\Delta E_0 = \Delta mc^2$ for chemical bonds. In future, increased precision will even allow precise bond energies to be determined in this way. Since binding energy is often radiated as light, one can say that these modern techniques make it possible to *weigh* light.

Ref. 200

Thinking about light and its mass was also the basis for Einstein’s first derivation of the mass–energy relation. When an object emits two equal light beams in opposite directions, its energy decreases by the emitted amount. Since the two light beams are equal in energy and momentum, the body does not move. If the same situation is described from the viewpoint of a moving observer, we get again that the *rest energy* of the object is

Challenge 415

$$E_0 = mc^2 \quad . \quad (111)$$

In summary, collisions and any other physical processes need relativistic treatment whenever the energies involved are a sizable fraction of the rest energies.

It is worth noting that human senses detect energies of quite different magnitudes. The eyes can detect light energies of about 1 aJ, whereas the sense of touch can detect only about 10 μ J. Which of the two systems is relativistic?

Challenge 432

How are energy and momentum related? The definitions of momentum (105) and energy (108) lead to two basic relations. First of all, their magnitudes are related by

Challenge 449

* For example, in the universe there may still be some extremely diluted, yet undiscovered, form of energy, called *dark matter*. It is predicted from (quite difficult) mass measurements. The issue has not been finally resolved.

$$m^2 c^4 = E^2 - p^2 c^2 \quad (112)$$

for all relativistic systems, be they objects or, as we will see below, radiation. For the momentum *vector* we get the other important relation

$$\mathbf{p} = \frac{E}{c^2} \mathbf{v} \quad , \quad (113)$$

which is equally valid for *any* type of moving energy, be it an object or a beam or a pulse of radiation. We will use both relations regularly in the rest of our ascent of the motion mountain, including the following situation.

Challenge 466

Collisions, virtual objects and tachyons

We have just seen that in relativistic collisions the conservation of total energy and momentum are intrinsic consequences of the definition of mass. So let us have a look at collisions in more detail, using these new concepts. Obviously a *collision* is a process, i.e. a series of events, for which

- the total momentum before the interaction and after the interaction is the same;
- the momentum is exchanged in a small region of space-time;
- for small velocities, the Galilean description is valid.

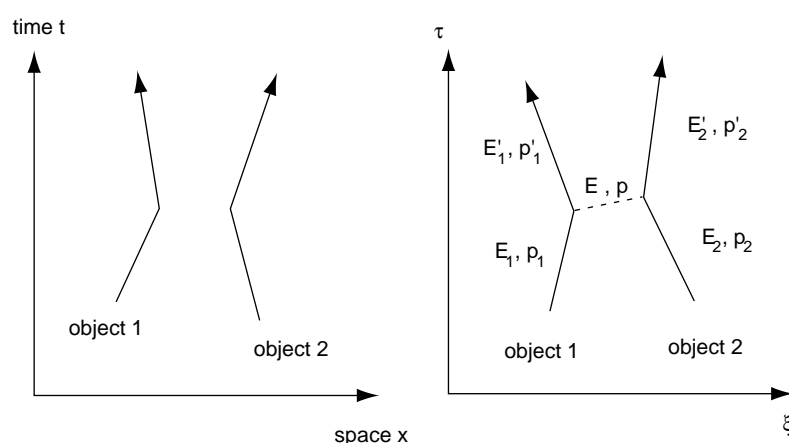

Figure 100 Space-time diagram of two interacting particles

In everyday life an *impact*, i.e. a short distance interaction, is the event at which both objects change momentum. But the two colliding objects are located at *different* points when this happens. A collision is therefore described by a space-time diagram such as the one in Figure 100, reminiscent of the Orion constellation. It is easy to check that the process described by such a diagram shows all the properties of a collision.

Ref. 201

The right-hand side of Figure 100 shows the same process seen from another, Greek, frame of reference. The Greek observer says that the first object has changed its momentum *before* the second one. That would mean that there is a short interval when momentum and energy are *not* conserved!

The only way to save the situation is to assume that there is an exchange of a third object, drawn with a dotted line. Let us find out what the properties of this object are. If we give numerical subscripts to the masses, energies and momenta of the two bodies, and give them a prime after the collision, the unknown mass obeys

Challenge 483

$$m^2 c^4 = E^2 - p^2 c^2 = (E_1 - E'_1)^2 - (p_1 - p'_1)^2 c^2 = 2E_1 E'_1 \left(\frac{v_1 v'_1}{c^2} - 1 \right) < 0 \quad . \quad (114)$$

This is a strange result, because it means that the unknown mass is an *imaginary* number, not a real and positive one! On top of that, we also see directly from the second graph that the exchanged object moves faster than light. It is a *tachyon*. In other words, collisions involve motion that is faster than light! We will see later that collisions are indeed the *only* processes where tachyons play a role in nature. Since the exchanged objects appear only during collisions, never on their own, they are called *virtual* objects, to distinguish them from the usual, *real* objects, which can move freely without restriction.* We will study their properties later on, in the part of the text on quantum theory. Only virtual objects may be tachyons. Real objects are always *bradyons*, or objects moving slower than light. Note that tachyons do not allow transport of energy faster than light, and that imaginary masses do not violate causality if and only if they are emitted and absorbed with the same probability. Can you confirm all this?

Challenge 500

There is an additional secret hidden in collisions. In the right-hand side of Figure 100, the tachyon is emitted by the first object and absorbed by the second one. However, it is easy to find an observer where the opposite happens. In short, the direction of travel of a tachyon depends on the observer! In fact, this is the first hint about *antimatter* we have encountered in our adventure. We will return to the topic in detail in the part of the text on quantum theory.

Challenge 517

See page 511

Studying quantum theory we will also discover that a general contact interaction between objects is not described by the exchange of a *single* virtual object, but by a continuous *stream* of virtual particles. In addition, for standard collisions of everyday objects the interaction turns out to be electromagnetic. In this case the exchanged particles are virtual photons. In other words, when a hand touches another, when it pushes a stone, or when a mountain keeps the trees on it in place, streams of virtual photons are continuously exchanged. This is one of the strange ways in which we will need to describe nature.

Systems of particles: no centre of mass

Relativity also forces us to eliminate the cherished concept of *centre of mass*. We can see this already in the simplest example possible: that of two equal objects colliding.

Figure 101 shows that from the viewpoint in which one of the two particles is at rest, there are at least three different ways to define the centre of mass. In other words, the centre of mass is not an observer-invariant concept. One can also deduce from the figure that the concept only makes sense for systems whose components move relative to each other with *small* velocities. For other cases, it is not uniquely definable. Will this hinder us in our ascent of the motion mountain? No. We are more interested in the motion of single particles than that of composite objects or systems.

Ref. 202

* More precisely, a virtual particle does not obey the relation $m^2 c^4 = E^2 - p^2 c^2$ valid for the real counterpart.

Why is most motion so slow?

For most everyday cases, the time intervals measured by two different observers are practically equal; only at large relative speeds, typically at more than a few percent of the speed of light, is a difference noted. Most such situations are microscopic. We have already mentioned the electrons inside a television tube or inside accelerators. Another example is the particles making up cosmic radiation, which produced so many of the mutations that are the basis of evolution of animals and plants on this planet. Later we will discover that the particles involved in radioactivity are also relativistic.

But why don't we observe any rapid *macroscopic* bodies? Moving bodies with relativistic velocities, including observers, have a property not found in everyday life; when they are involved in a collision, part of their energy is converted into new matter via $E = \gamma mc^2$. In the history of the universe this has happened so many times that practically all the bodies still in relativistic motion are microscopic particles.

A second reason for the disappearance of rapid relative motion is radiation damping. Can you imagine what happens to charges during collisions or to charges in a bath of light?

Challenge 534

In short, almost all matter in the universe moves with small velocity relative to other matter. The few known counterexamples are either very old, such as the quasar jets mentioned above, or stop after a short time. The huge energies necessary for macroscopic relativistic motion are still found, e.g. in supernova explosions, but cease to exist after only a few weeks. Therefore the universe is mainly filled with slow motion because it is *old*. We will determine its age shortly.

See page

Four-vectors

To describe motion consistently for *all* observers, we have to introduce some new quantities. Two ideas are used. First of all, motion of particles is seen as a sequence of events. To describe events with precision, we use event coordinates, also called *4-coordinates*. These are written as

$$\mathbf{x} = (ct, \mathbf{r}) = (ct, x, y, z) = x^i \quad . \quad (115)$$

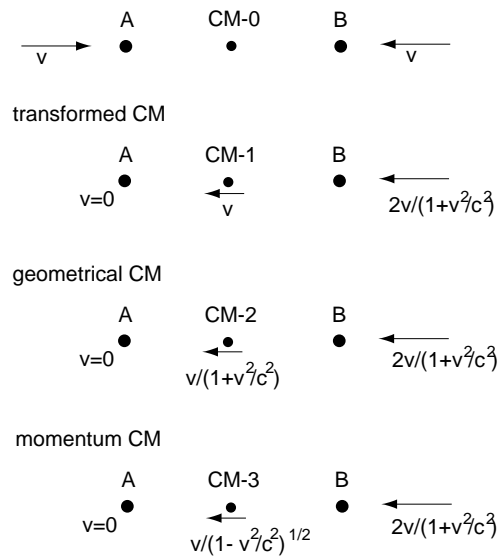

Figure 101 There is no way to define a centre of mass

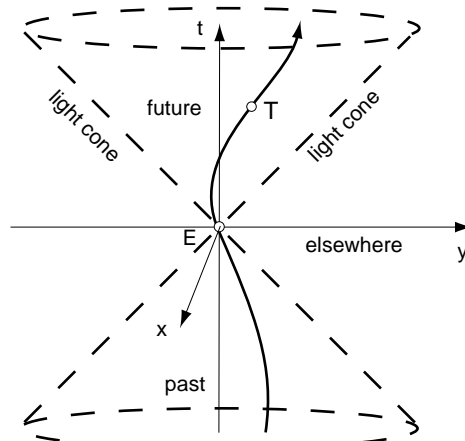

Figure 102 The space-time diagram of a moving object T

In this way, an event is a point in four-dimensional space-time, and is described by four coordinates. The coordinates are called the zeroth, namely time $x^0 = ct$, the first, usually called $x^1 = x$, the second, $x^2 = y$, and the third, $x^3 = z$. One can then define a *distance* d between events as the length of the difference vector. In fact, one usually uses the square of the length, to avoid all those nasty square roots. In special relativity, the magnitude ('squared length') of a vector is always defined through

$$\mathbf{x}\mathbf{x} = x_0^2 - x_1^2 - x_2^2 - x_3^2 = ct^2 - x^2 - y^2 - z^2 = x_a x^a = \eta_{ab} x^a x^b = \eta^{ab} x_a x_b \quad . \quad (116)$$

In this equation we have introduced for the first time two notations that are useful in relativity. First of all, we sum over repeated indices. In other words, $x_a x^a$ means the sum over all products $x_a x^a$ for each index a , as just used above. Second, for every 4-vector \mathbf{x} we distinguish two ways to write the coordinates, namely coordinates with superscripts and coordinates with subscripts. (In three dimensions, we only use subscripts.) They are related by the following general relation

$$x_a = \eta_{ab} x^b = (ct, -x, -y, -z) \quad , \quad (117)$$

where we have introduced the so-called *metric* η^{ab} , an abbreviation of the matrix*

$$\eta^{ab} = \eta_{ab} = \begin{pmatrix} 1 & 0 & 0 & 0 \\ 0 & -1 & 0 & 0 \\ 0 & 0 & -1 & 0 \\ 0 & 0 & 0 & -1 \end{pmatrix} \quad . \quad (118)$$

Don't panic; this is all, and it won't get more difficult! We now go back to physics.

The magnitude of a position or distance vector, also called the space-time *interval*, is essentially the proper time times c^2 . The *proper time* is the time shown by a clock moving

* Note that 30% of all physics textbooks use the negative of η as metric, the so-called *spacelike convention*, and thus have negative signs in this definition. In this text, like in 70% of all physics texts, we use the *timelike convention*.

in a straight line and constant velocity from the starting point to the end point in space-time. The difference from the usual 3-vectors is that the magnitude of the interval can be positive, negative, or even zero. For example, if the start and end points in space-time require motion with the speed of light, the proper time is zero, as indeed is required for null vectors. If the motion is slower than the speed of light, the squared proper time is positive, and the distance is timelike. For negative intervals, and thus imaginary proper times, the distance is spacelike.*

Now we are ready to calculate and measure motion in four dimensions. The measurements are based on one central idea. Given the coordinates of a particle, one cannot define its velocity as the derivative of its coordinates with respect to time, since time and temporal sequences depend on the observer. The solution is to define all observables with respect to the just mentioned *proper time* τ , which is defined as the time shown by a clock attached to the object. In relativity, motion and change are always measured with respect to clocks attached to the moving system. In particular, *relativistic velocity* or *4-velocity* \mathbf{u} of a body is thus defined as the change of the event coordinates or *4-coordinates* $\mathbf{r} = (ct, \mathbf{x})$ with proper time, i.e. as

$$\mathbf{u} = d\mathbf{r}/d\tau \quad . \quad (119)$$

Using $dt = \gamma d\tau$ and thus

$$\frac{dx}{d\tau} = \frac{dx}{dt} \frac{dt}{d\tau} = \gamma \frac{dx}{dt} \quad \text{where as usual} \quad \gamma = \frac{1}{\sqrt{1 - v^2/c^2}} \quad , \quad (120)$$

we get the relation with the 3-velocity $\mathbf{v} = d\mathbf{x}/dt$:

$$u^0 = \gamma c \quad , \quad u^i = \gamma v_i \quad \text{or} \quad \mathbf{u} = (\gamma c, \gamma \mathbf{v}) \quad . \quad (121)$$

For small velocities we have $\gamma \approx 1$, and then the last three components of the 4-velocity are those of the usual, Galilean 3-velocity. For the magnitude of the 4-velocity \mathbf{u} we find $\mathbf{u}\mathbf{u} = u_a u^a = \eta_{ab} u^a u^b = c^2$, which is therefore independent of the magnitude of the 3-velocity \mathbf{v} and makes it a timelike vector, i.e. a vector *inside* the light cone.**

Challenge 568 Note that the magnitude of a 4-vector can be zero even though all components of such so-called *null* vectors are different from zero. Which motion has a null velocity vector?

Similarly, the *relativistic acceleration* or *4-acceleration* \mathbf{b} of a body is defined as

$$\mathbf{b} = d\mathbf{u}/d\tau = d\mathbf{x}^2/d\tau^2 \quad . \quad (123)$$

* In the latter case, the negative of the magnitude, which then is a positive number, is called the squared *proper distance*. The proper distance is the length measured by an odometer as the object moves along that distance.

** In general, a *4-vector* is defined as a quantity (h_0, h_1, h_2, h_3) , which transforms as

$$\begin{aligned} h'_0 &= \gamma(h_0 - v h_1/c) \\ h'_1 &= \gamma(h_1 - v h_0/c) \\ h'_2 &= h_2 \\ h'_3 &= h_3 \end{aligned} \quad (122)$$

when changing from one inertial observer to another moving with a relative velocity v in x direction; the corresponding generalization for the other coordinates are understood. Can you deduce the addition theorem (83) from this definition, applying it to 4-velocity?

Challenge 551

Using $d\gamma/d\tau = \gamma d\gamma/dt = \gamma^4 \mathbf{v}\mathbf{a}/c^2$, one gets the following relations between the four components of \mathbf{b} and the 3-acceleration $\mathbf{a} = d\mathbf{v}/dt$:

Ref. 204

$$b^0 = \gamma^4 \frac{\mathbf{v}\mathbf{a}}{c} \quad , \quad b^i = \gamma^2 a_i + \gamma^4 \frac{(\mathbf{v}\mathbf{a})v_i}{c^2} \quad . \quad (124)$$

The magnitude of the 4-acceleration is rapidly found via $\mathbf{b}\mathbf{b} = \eta_{cd}b^c b^d = -\gamma^6(a^2 - (\mathbf{v} \times \mathbf{a})^2/c^2)$ and thus it does depend on the value of the 3-acceleration \mathbf{a} . (What is the connection between 4-acceleration and 3-acceleration for an observer moving with the same speed as the object?) We note that 4-acceleration lies *outside* the light cone, i.e. that it is a spacelike vector, and that $\mathbf{b}\mathbf{u} = \eta_{cd}b^c u^d = 0$, which means that the 4-acceleration is always perpendicular to the 4-velocity.* We also note from the expression that accelerations, in contrast to velocities, cannot be called relativistic; the difference between b_i and a_i or between their two magnitudes does not depend on the value of a_i , but only on the value of the speed v . In other words, accelerations require relativistic treatment only when the involved velocities are relativistic. If the velocities involved are low, even the highest accelerations can be treated with Galilean methods.

Challenge 585

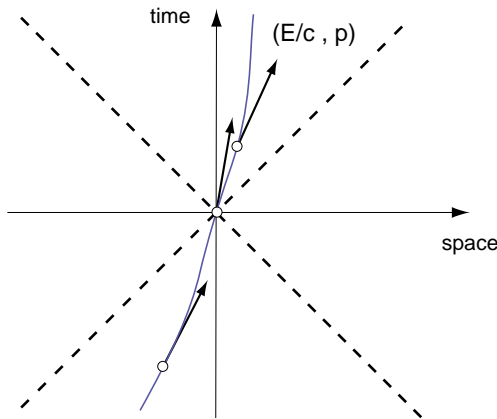

Figure 103 Energy-momentum is tangent to the world line
 This follows directly from the definition, since

To describe motion, we also need the concept of momentum. The 4-momentum is defined by setting

$$\mathbf{P} = m\mathbf{u} \quad (127)$$

and is therefore related to 3-momentum \mathbf{p} by

$$\mathbf{P} = (\gamma mc, \gamma m\mathbf{v}) = (E/c, \mathbf{p}) \quad . \quad (128)$$

For this reason 4-momentum is also called the *energy-momentum 4-vector*. In short, the 4-momentum of a body is given by mass times 4-displacement per proper time. This is the simplest possible definition of momentum and energy. The energy-momentum 4-vector, also called *momenergy*, like the 4-velocity, is *tangent* to the world line of a particle.

$$(E/c, \mathbf{p}) = (\gamma mc, \gamma m\mathbf{v}) = m(\gamma c, \gamma \mathbf{v}) = m(dt/d\tau, d\mathbf{x}/d\tau) \quad . \quad (129)$$

* Similarly, the *relativistic jerk* or 4-jerk \mathbf{J} of a body is defined as

$$\mathbf{J} = d\mathbf{b}/d\tau = d^2\mathbf{u}/d\tau^2 \quad . \quad (125)$$

Challenge 602 For the relation with the 3-jerk $\mathbf{j} = d\mathbf{a}/dt$ we then get

$$\mathbf{J} = (J^0, J^i) = \left(\frac{\gamma^5}{c} (\mathbf{j}\mathbf{v} + a^2 + 4\gamma^2 \frac{(\mathbf{v}\mathbf{a})^2}{c^2}) \quad , \quad \gamma^3 j_i + \frac{\gamma^5}{c^2} ((\mathbf{j}\mathbf{v})v_i + a^2 v_i + 4\gamma^2 \frac{(\mathbf{v}\mathbf{a})^2 v_i}{c^2} + 3(\mathbf{v}\mathbf{a})a_i) \right) \quad (126)$$

Challenge 619 which we will use later on. Surprisingly, \mathbf{J} does not vanish when \mathbf{j} vanishes. Why?

The (square of the) length of momenergy, namely $\mathbf{P}\mathbf{P} = \eta_{ab}P^aP^b$, is by definition the same for all inertial observers and found to be

$$E^2/c^2 - p^2 = m^2c^2 \quad , \quad (130)$$

thus confirming a result given above. We have already mentioned that energies or situations are called *relativistic* if the kinetic energy $T = E - E_0$ is not negligible when compared to the rest energy $E_0 = mc^2$. A particle whose kinetic energy is much higher than its rest mass is called *ultrarelativistic*. Particles in accelerators or in cosmic rays fall into this category.

Challenge 636 (What is their energy–momentum relation?)

Note that by the term ‘mass’ m we always mean what is sometimes also called the *rest mass*. This name derives from the bad habit of many science fiction and high-school books of calling the product γm the *relativistic mass*. Workers in the field reject this concept, as did Einstein himself, and they also reject the often heard sentence that ‘(relativistic) mass increases with velocity’. This last statement is more at the intellectual level of the tabloid press, and not worthy of any motion expert.

Ref. 203

We note that 4-force \mathbf{K} is defined as

$$\mathbf{K} = d\mathbf{P}/d\tau = m\mathbf{b} \quad (131)$$

and that, therefore, contrary to an often heard statement, force remains mass times acceleration in relativity. From the definition of \mathbf{K} we deduce the relation with 3-force $\mathbf{F} = d\mathbf{p}/dt = md(\gamma\mathbf{v})/dt$, namely*

Ref. 204, 205

$$\mathbf{K} = (K^0, K^i) = (\gamma^4 m\mathbf{v}\mathbf{a}/c, \gamma^2 ma_i + \gamma^4 v_i \frac{m\mathbf{v}\mathbf{a}}{c^2}) = \left(\frac{\gamma}{c} \frac{dE}{dt}, \gamma \frac{d\mathbf{p}}{dt}\right) = \left(\gamma \frac{\mathbf{F}\mathbf{v}}{c}, \gamma \mathbf{F}\right) \quad . \quad (132)$$

Challenge 670 Also the 4-force, like the 4-acceleration, is orthogonal to the 4-velocity. The meaning of the zeroth component of the 4-force can be easily recognized: it is the *power* required to accelerate the object. But, since force is not an important concept in physics, we now turn to a different topic.

See page 102

Rotation in relativity

If at night we turn around our own axis while looking at the sky, the stars move with a much higher velocity than that of light. Most stars are masses, not images. Their speed should be limited by that of light. How does this fit with special relativity?

The example helps to clarify in another way what the limit velocity actually is. Physically speaking, a rotating sky does *not* allow superluminal energy transport, and thus is not in contrast with the concept of a limit speed. Mathematically speaking, the speed of light limits relative velocities *only* between objects that come *near* to each other. To compare velocities of distant objects is only possible if all velocities involved are constant in time; this is not the case in the present example. Avoiding this limitation is one of the reasons to prefer the differential version of the Lorentz transformations. In many general cases relative velocities of *distant* objects can be higher than the speed of light. We encountered a first ex-

See page 187

* Some authors define 3-force as $\mathbf{F} = d\mathbf{p}/dt$; then \mathbf{K} looks slightly different. In any case, it is important to note that in relativity, 3-force \mathbf{F} is indeed proportional to 3-acceleration \mathbf{a} ; however, force and acceleration are not parallel to each other. In fact, one finds $\mathbf{F} = \gamma m\mathbf{a} + (\mathbf{F}\mathbf{v})\mathbf{v}/c^2$. In contrast, in relativity 3-momentum is not proportional to 3-velocity, but parallel to it.

Challenge 653

ample above, when discussing the car in the tunnel, and we will encounter a few additional examples shortly.

See page 210

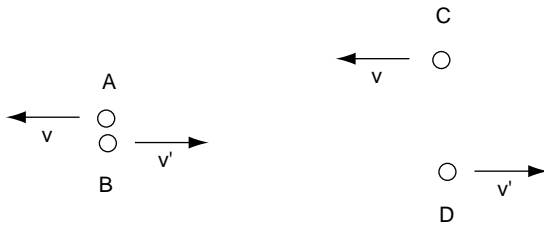

Figure 104 On the definition of relative velocity

With this clarification, we can now have a short look at *rotation* in relativity. The first question is how lengths and times change in a rotating frame of reference. You may want to check that an observer in a rotating frame agrees with a non-rotating colleague on the radius of a rotating body; however, both find that the rotating body has a *different circumference* from before it started rotating. Slo-

Challenge 687

pily speaking, the value of π *changes* for rotating observers: it increases with rotation speed.

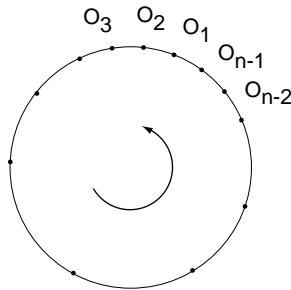

Figure 105 Observers on a rotating object

Rotating bodies behave strangely in many ways. For example, one gets into trouble when one tries to synchronize clocks mounted on a circle around the rotation centre. If one starts synchronizing the clock at O_2 with that at O_1 , continuing up to clock O_n , one finds that the last clock is *not* synchronized with the first. This result reflects the change in circumference just mentioned. In fact, a careful study shows that the measurements of length and time intervals lead all observers O_k to conclude that they live in a rotating space-time. Rotating disks can thus be used as an introduction to general relativity, where this curvature and its effects form the central topic. More about this in the next chapter.

Is angular velocity limited? Yes; the tangential speed in an inertial frame of reference cannot exceed that of light. The limit thus depends on the *size* of the body in question. That leads to a neat puzzle: can one *see* objects rotating very rapidly?

Challenge 704

We mention that 4-angular momentum is defined naturally as

$$l^{ab} = x^a p^b - x^b p^a \quad . \quad (133)$$

In other words, 4-angular momentum is a *tensor*, not a vector, as shown by its two indices. Angular momentum is also obviously conserved in special relativity, so that there are no surprises on this topic.

Challenge 721

As usual, the moment of inertia is defined as the proportionality factor between angular velocity and angular momentum.

– CS – Text to be filled in. – CS –

Obviously, for a rotating particle, the rotational energy is part of the rest mass. You may want to calculate the fraction for the earth and the sun. It is not large. By the way, how would you determine whether a small particle, too small to be seen, is rotating?

Challenge 738

Challenge 755

The action of a free particle

See page 116 If we want to describe relativistic motion of a free particle with an extremal principle, we need a definition of the action. We already know that physical action measures the change occurring in a system. For an inertially moving or free particle, the only change is the ticking of its proper clock. As a result, the action of a free particle will be proportional to the elapsed proper time. In order to get the standard unit of energy times time, or Js, for the action, the first guess for the action of a free particle is

$$S = -mc^2 \int_{\tau_1}^{\tau_2} d\tau \quad , \quad (134)$$

Challenge 772 where τ is the proper time along its path. This is indeed the correct expression. It shows that the proper time is maximal for straight-line motion with constant velocity. Can you confirm this? All particles move in such a way that their proper time is maximal. In other words, we again find that in nature things change as little as possible. Nature is like a wise old man: its motions are as slow as possible. If you prefer, they are maximally effective.

The action can also be written in more complex ways, in order to frighten the hell out of readers. These other, equivalent ways to write it prepare for the future, in particular for general relativity:

$$S = \int L dt = -mc^2 \int_{t_1}^{t_2} \frac{1}{\gamma} dt = -mc \int_{\tau_1}^{\tau_2} \sqrt{u_a u^{a'}} d\tau = -mc \int_{s_1}^{s_2} \sqrt{\eta^{ab} \frac{dx_a}{ds} \frac{dx_b}{ds}} ds \quad , (135)$$

where s is some arbitrary, but monotonically increasing function of τ – such as τ itself – and the *metric* $\eta^{\alpha\beta}$ of special relativity is given as usual as

$$\eta^{ab} = \eta_{ab} = \begin{pmatrix} 1 & 0 & 0 & 0 \\ 0 & -1 & 0 & 0 \\ 0 & 0 & -1 & 0 \\ 0 & 0 & 0 & -1 \end{pmatrix} \quad . \quad (136)$$

Challenge 789 You can easily confirm the form of the action by deducing the equation of motion with the usual procedure.

See page 116 In short, nature is in not a hurry: every object moves in a such way that its own clock shows the *longest* delay possible, compared with any alternative motion nearby.* This general principle is also valid for particles under the influence of gravity, as we will see in the section on general relativity, and under the influence of electric or magnetic interactions. In fact, it is valid in all cases. In nature, *proper time is always maximal*. Above, we saw that the action measures the change going on in a system. Minimizing proper time is the way that nature minimizes change. We thus again find that nature is the opposite of a Hollywood movie; nature changes in the most economical way possible. Speculating on the deeper meaning of this result is left to your personal preferences; enjoy it!

Challenge 806 * For the massless neutrinos, the action does not work. Why? Can you find an alternative?

Conformal transformations: Why is the speed of light constant?

The distinction between space and time in special relativity depends on the observer. On the other hand, all inertial observers do agree on the position, shape and orientation of the light cone at a point. The light cones at each point thus are the basic physical ‘objects’ with which space-time is described in the theory of relativity. Given the importance of light cones, we might ask if inertial observers are the only ones that observe the same light cones. Interestingly, it turns out that there are *other* such observers.

The first group of these additional observers is made up of those using different units of measurement, namely units in which all time and length intervals are multiplied by a *scale factor* λ . The transformations among these points of view are given by

$$x_a \mapsto \lambda x_a \quad (137)$$

and are called *dilations*.

A second type of additional observers are found by applying the so-called *special conformal transformations*. They are combinations of an *inversion*

$$x_a \mapsto \frac{x_a}{x^2} \quad (138)$$

with a *translation* by a vector b_a , namely

$$x_a \mapsto x_a + b_a \quad , \quad (139)$$

and a second inversion. This gives for the expression for the special conformal transformations

$$x_a \mapsto \frac{x_a + b_a x^2}{1 + 2b_a x^a + b^2 x^2} \quad \text{or} \quad \frac{x_a}{x^2} \mapsto \frac{x_a}{x^2} + b_a \quad . \quad (140)$$

These transformations are called *conformal* because they do not change angles of (infinitesimally) small shapes, as you may want to check. The transformations thus leave the *form* (of infinitesimally small objects) unchanged. For example, they transform infinitesimal circles into infinitesimal circles. They are called *special* because the full *conformal group* includes the dilations and the inhomogeneous Lorentz transformations as well.*

Challenge 823

The way in which special conformal transformations leave light cones invariant is rather subtle.

– CS – Text to be filled in. – CS –

Note that, since dilations do not commute with time translations, there is no conserved quantity associated with this symmetry. (The same happens with Lorentz boosts; in contrast,

Challenge 840

* The set of all *special* conformal transformations forms a group with four parameters; adding dilations and the inhomogeneous Lorentz transformations one gets fifteen parameters for the *full* conformal group. The conformal group is locally isomorphic to $SU(2,2)$ and to the simple group $SO(4,2)$; these concepts are explained in Appendix D. Note that all this is true only for *four* space-time dimensions; in *two* dimensions, the other important case, especially in string theory, the conformal group is isomorphic to the group of arbitrary analytic coordinate transformations, and is (thus) infinite-dimensional.

See page 842

rotations and spatial translations do commute with time translations and thus do lead to conserved quantities.)

In summary, vacuum is conformally invariant – in the special way just mentioned – and thus also dilation invariant. This is another way to say that vacuum alone is not sufficient to define lengths, as it does not fix a scale factor. As expected, matter is necessary to do so. Indeed, (special) conformal transformations are not symmetries of situations containing matter. Only vacuum is conformally invariant; nature as a whole is not.

However, conformal invariance, or the invariance of light cones, is sufficient to allow velocity measurements. Obviously, conformal invariance is also *necessary* for velocity measurements, as you might want to check.

Challenge 857

As a final remark, conformal invariance includes inversion symmetry. Inversion symmetry means that the large and small scales of a vacuum are related. It thus seems as if the constancy of the speed of light is related to the existence of inversion symmetry. This mysterious connection gives us a glimpse of the adventures we will encounter in the third part of our ascent of Motion Mountain. Conformal invariance turns out to be an important property of will produce many incredible surprises.*

Accelerating observers

So far, we have only studied what inertial, or free-flying, observers say to each other when they talk about the same observation. For example, we saw that moving clocks always run slow. The story gets even more interesting when one or both of the observers are accelerating.

One sometimes hears that special relativity cannot be used to describe accelerating observers. That is wrong: the argument would imply that also Galilean physics could not be used for accelerating observers, in contrast to everyday experience. Special relativity's only limitation is that it cannot be used in non-flat, i.e. curved, space-time. Accelerating bodies do exist in flat space-times, and therefore can be discussed in special relativity.

Ref. 206

As an appetizer, let us see what an accelerating, Greek, observer says about the clock of an inertial, Roman, one, and vice versa. Assume that the Greek observer moves along $\mathbf{x}(t)$, as observed by the inertial Roman one. In general, the Roman/Greek clock rate ratio is given by $\Delta\tau/\Delta t = (\tau_2 - \tau_1)/(t_2 - t_1)$, where the Greek coordinates are constructed with a simple procedure: take the set of events defined by $t = t_1$ and $t = t_2$, and determine where these sets intersect the time axis of the Greek observer, and call them τ_1 and τ_2 .** We see

* The conformal group does not appear only in the kinematics of special relativity; it is the symmetry group of all physical interactions, such as electromagnetism, if all the particles involved have zero mass, as is the case for the photon. Any field that has mass cannot be conformally invariant; therefore conformal invariance is not an exact symmetry of all of nature. Can you confirm that a mass term $m\phi^2$ in a Lagrangian is not conformally invariant?

Challenge 874

However, since all particles observed up to now have masses that are many orders of magnitude smaller than the Planck mass, from a global viewpoint it can be said that they have almost vanishing mass; conformal symmetry then can be seen as an *approximate* symmetry of nature. In this view, all massive particles should be seen as small corrections, or perturbations, of massless, i.e. conformally invariant, fields. Therefore, for the construction of a fundamental theory, conformally invariant Lagrangians are often assumed to provide a good starting approximation.

** These sets form what mathematicians call *hypersurfaces*.

that the clock ratio of a Greek observer, in the case that the Greek observer is inertial and moving with velocity v as observed by the Roman one, is given by

$$\frac{\Delta\tau}{\Delta t} = \frac{d\tau}{dt} = \sqrt{1 - v^2/c^2} = \frac{1}{\gamma_v} \tag{141}$$

as we are now used to. We find again that moving clocks run slow.

Challenge 891

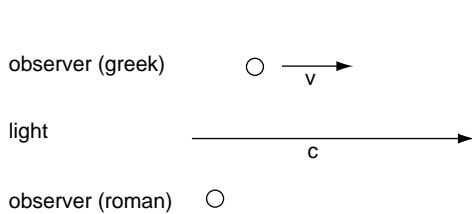

For accelerated motions, the differential version of the reasoning is necessary. In other words, the Roman/Greek clock rate ratio is again $d\tau/dt$, and τ and $\tau + d\tau$ are calculated in the same way as just defined from the times t and $t + dt$. Assume again that the Greek observer moves along $\mathbf{x}(t)$, as measured by the Roman one. We find directly that

Ref. 206

Figure 106 Simplified situation for an inertial and an accelerated observer

$$\tau = t - \mathbf{x}(t)\mathbf{v}(t) \tag{142}$$

and thus

$$\tau + d\tau = (t + dt) - [\mathbf{x}(t) + dt\mathbf{v}(t)][\mathbf{v}(t) + dt\mathbf{a}(t)] \tag{143}$$

Together, this yields

$$'d\tau/dt' = \gamma_v(1 - \mathbf{v}\mathbf{v}/c^2 - \mathbf{x}\mathbf{a}/c^2) \tag{144}$$

a result showing that accelerated clocks can run *fast* instead of slow, depending on their position \mathbf{x} and the sign of their acceleration \mathbf{a} . There are quotes in the expression because we see directly that the Greek observer notes

$$'dt/d\tau' = \gamma_v \tag{145}$$

which is *not* the inverse of equation (144). This difference becomes most apparent in the simple case of two clocks with the same velocity, one of which is accelerated constantly towards the origin with magnitude g , whereas the other moves inertially. We then have

$$'d\tau/dt' = 1 + gx \tag{146}$$

and

$$'dt/d\tau' = 1 \tag{147}$$

We will encounter this situation shortly.

Another difference with the case for velocities is the way accelerations change under change of viewpoints. Let us only take the simple case in which everything moves along the x -axis: the object and two inertial observers. If the Roman observer measures an acceleration $a = dv/dt = d^2x/dt^2$, and the Greek observer, also *inertial* in this case, an acceleration $\alpha = d\omega/d\tau = d^2\xi/d\tau^2$, we get

Ref. 207

$$\gamma_v^3 a = \gamma_\omega^3 \alpha \quad . \quad (148)$$

The relation shows that accelerations are *not* Lorentz invariant; they are so only if the velocities are small compared to the speed of light. This is in contrast to our everyday experience, where accelerations are independent of the observer. Note that expression (148) simplifies in the case that the accelerations are measured at a time t in which v vanishes; in that case the acceleration a is called proper acceleration, as its value describes what the Roman observer *feels*, e.g. the experience of being pushed into the accelerating seat.

In summary, acceleration complicates many issues. This is such an interesting topic that it merits a deeper investigation. To keep matters simple, we only study *constant* accelerations.

See page 314 Interestingly, this situation is a good introduction to black holes and, as we will see shortly, to the whole universe.

Accelerating frames of reference

How does we check whether we live in an inertial frame of reference? An *inertial frame (of reference)* has two properties: first, the speed of light is constant. In other words, for any two observers in that frame the ratio c between twice the distance measured with a ruler and the time taken by light to travel from one point to another and back again is always the same. The ratio is independent of time and of the position of the observers. Second, lengths and distances measured with a ruler are described by Euclidean geometry. In other words, rulers behave as in daily life; in particular, distances found by counting how many rulers (rods) have to be laid down end to end, the so-called *rod distances*, behave as in everyday life. For example, they follow Pythagoras' theorem in the case of right-angled triangles.

Equivalently, an inertial frame is one for which all clocks always remain synchronized and whose geometry is Euclidean. In particular, in an inertial frame all observers at fixed coordinates always remain at rest with respect to each other. This last condition is, however, a more general one. Interestingly, there are other, non-inertial, situations where this is the case.

Non-inertial frames, or *accelerating frames*, are useful concepts special relativity. In fact, we all live in such a frame. We can use special relativity to describe it in the same way that we used Galilean physics to describe it at the beginning of our journey.

A general *frame of reference* is a continuous set of observers remaining at rest with respect to each other. Here, 'at rest with respect to each other' means that the time for a light signal to go from one observer to another and back again is constant in time, or equivalently, that the rod distance between the two observers is constant in time. Any frame of reference can therefore also be called a *rigid* collection of observers. We therefore note that a general frame of reference is *not* the same as a set of coordinates; the latter usually is *not* rigid. In the special case that we have chosen the coordinate system in such a way that all the rigidly connected observers have constant coordinate values, we speak of a *rigid coordinate system*. Obviously, these are the most useful to describe accelerating frames of reference. *

Ref. 209 * There are essentially only two other types of rigid coordinate frames, apart from the inertial frames:

- the frame $ds^2 = dx^2 + dy^2 + dz^2 - c^2 dt (1 + g_k x_k / c^2)^2$ with arbitrary, but constant acceleration of the origin. The acceleration is $\mathbf{a} = -\mathbf{g}(1 + \mathbf{g}\mathbf{x}/c^2)$;
- the uniformly rotating frame $ds^2 = dx^2 + dy^2 + dz^2 + 2\omega(-y dx + x dy) dt - (1 - r^2 \omega^2 / c^2) dt^2$. Here the z -axis is the rotation axis, and $r^2 = x^2 + y^2$.

Note that if two observers both move with a velocity \mathbf{v} , as measured in some *inertial* frame, they observe that they are at rest with respect to each other *only* if this velocity is *constant*. Again we find, as above, that two persons tied to each other by a rope, and at a distance such that the rope is under tension, will see the rope break (or hang loose) if they accelerate together to (or decelerate from) relativistic speeds in precisely the same way. Relativistic acceleration requires careful thinking.

Ref. 208

Challenge 908

An observer who always *feels* the *same* force on his body is called *uniformly* accelerating. More precisely, a uniformly accelerating observer Ω is thus an observer whose acceleration at every moment, measured by the inertial frame with respect to which the observer is at rest *at that moment*, always has the same value \mathbf{b} . It is important to note that uniform acceleration is *not* uniformly accelerating when always observed from the *same* inertial frame K . This is an important difference with respect to the Galilean case.

For uniformly accelerated motion in the sense just defined, we need

$$\mathbf{b} \cdot \mathbf{b} = -g^2 \tag{149}$$

where g is a constant independent of t . The simplest case is uniformly accelerating motion that is also *rectilinear*, i.e. for which the acceleration \mathbf{a} is parallel to \mathbf{v} at one instant of time and (therefore) for all other times as well. In this case we can write, using three-vectors,

Ref. 211

Challenge 925

$$\gamma^3 \mathbf{a} = \mathbf{g} \quad \text{or} \quad \frac{d\gamma \mathbf{v}}{dt} = \mathbf{g} \tag{150}$$

Taking the direction we are talking about to be the x -coordinate, and solving for $v(t)$, we get

$$v = \frac{gt}{\sqrt{1 + \frac{g^2 t^2}{c^2}}} \tag{151}$$

where it was assumed that $v_0 = 0$. We note that for small times we get $v = gt$ and for large times $v = c$, both as expected. The momentum of the Greek observer increases linearly with time, again as expected. Integrating, we find that the accelerated observer Ω moves along the path

Challenge 942

$$x(t) = \frac{c^2}{g} \sqrt{1 + \frac{g^2 t^2}{c^2}} \tag{152}$$

where it was assumed that $x_0 = c^2/g$, in order to keep the expression simple. Because of this result, visualized in Figure 107, a rectilinearly and uniformly accelerating observer is said to undergo *hyperbolic* motion. For small times, the world-line reduces to the usual

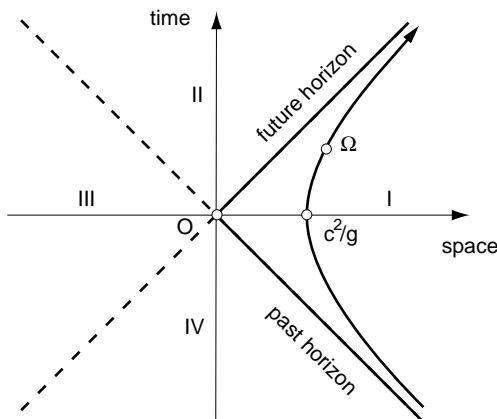

Figure 107 The hyperbolic motion of a rectilinearly, uniformly accelerating observer and its event horizons

$x = gt^2/2 + x_0$, whereas for large times the result is $x = ct$, as expected. The motion is thus uniformly accelerated only for the moving body itself, *not* for an outside observer.

The proper time τ of the accelerated observer is related to the time t of the inertial frame in the usual way by $dt = \gamma d\tau$. Using the expression for the velocity $v(t)$ of equation (151)

Ref. 211, 212 we get*

$$t = \frac{c}{g} \sinh \frac{g\tau}{c} \quad \text{and} \quad x = \frac{c^2}{g} \cosh \frac{g\tau}{c} \quad (153)$$

for the relationship between proper time τ and the time t and the position x measured by the external, inertial Roman observer. We will encounter this relation again during the study of black holes.

Does all this sound boring? Just imagine accelerating on a motor bike at $g = 10 \text{ m/s}^2$ for the proper time τ of 25 years. That would bring you beyond the end of the known universe! Isn't that worth a try? Unfortunately, neither motor bikes nor missiles that accelerate like this exist, as their fuel tank would have to be enormous. Can you confirm this even for the most optimistic case?

Challenge 959

For uniform acceleration, the coordinates transform as

$$\begin{aligned} t &= \left(\frac{c}{g} + \frac{\xi}{c} \right) \sinh \frac{g\tau}{c} \\ x &= \left(\frac{c^2}{g} + \xi \right) \cosh \frac{g\tau}{c} \\ y &= \nu \\ z &= \zeta \end{aligned} \quad (154)$$

where τ now is the time coordinate in the Greek frame. One notes also that the space-time interval $d\sigma$ becomes

$$d\sigma^2 = (1 + g\xi/c^2)^2 c^2 d\tau^2 - d\xi^2 - d\nu^2 - d\zeta^2 = c^2 dt^2 - dx^2 - dy^2 - dz^2 \quad (155)$$

and since for $d\tau = 0$ distances are given by Pythagoras' theorem, the Greek reference frame is indeed rigid.

Ref. 210

After this forest of formulae, let's tackle a simple question. The Roman observer O sees the Greek observer Ω departing with acceleration g , moving further and further away, following equation (152). What does the Greek observer say about his Roman colleague? With all the experience we have now, that is easy. At each point of his trajectory the Greek observer sees that O has the coordinate $\tau = 0$ (can you confirm this?), which means that the distance to the Roman observer, as seen by Greek one, is the same as the space-time interval

Challenge 976

Ref. 214 $O\Omega$. Using expression (152) this turns out to be

$$d_{O\Omega} = \sqrt{\xi^2} = \sqrt{x^2 - c^2 t^2} = c^2/g \quad , \quad (156)$$

which, surprisingly enough, is constant in time! In other words, the Greek observer will observe that he stays at a constant distance from the Roman one, in complete contrast to

Ref. 213 * Use your favourite mathematical formula collection to deduce this. The abbreviations $\sinh y = (e^y - e^{-y})/2$ and $\cosh y = (e^y + e^{-y})/2$ imply that $\int dy/\sqrt{y^2 + a^2} = \operatorname{arsinh} y/a = \operatorname{Arsh} y/a = \ln(y + \sqrt{y^2 + a^2})$.

what the Roman observer says. Take your time to check this strange result in some other way. We will need it again later on, to explain why the earth does not explode. (Are you able to guess the relationship to this issue?)

Challenge 993

Two pretty and challenging problems are first, to state how the acceleration ratio enters mass definition in special relativity, and second, to deduce the addition theorem for accelerations.

See page 191

Challenge 1010

Event horizons

The surprises of accelerated motion are not finished yet. Of special interest is the trajectory, in the rigidly accelerated frame coordinates ξ and τ , of an object located at the departure point $x = x_0 = c^2/g$ at all times t . One gets the two relations*

Challenge 1027

$$\begin{aligned}\xi &= -\frac{c^2}{g}\left(1 - \operatorname{sech}\frac{g\tau}{c}\right) \\ d\xi/d\tau &= -c \operatorname{sech}\frac{g\tau}{c} \tanh\frac{g\tau}{c} .\end{aligned}\quad (158)$$

These equations are strange. It is clear that for large times τ the coordinate ξ approaches the limit value $-c^2/g$ and that $d\xi/d\tau$ approaches zero. The situation is similar to a car accelerating away from a woman standing on a long road. Seen from the car, the woman moves away; however, after a while, the only thing one notices is that she is slowly approaching the horizon. In Galilean physics, both the car driver and the woman on the road see the other person approaching each other's horizon; in special relativity, only the accelerated observer makes this observation.

Studying a graph of the situation confirms the result. In Figure 108 we can see that light emitted from any event in regions II and III cannot reach the Greek observer. Those events are hidden from him and cannot be observed. Strangely enough, however, light from the Greek observer *can* reach region II. The boundary between the part of space-time that can be observed and that which cannot is called the *event horizon*. In relativity, event horizons act like one-way gates for light and for any other signal. For completeness, the graph also shows the past event horizon.

In summary, not all events observed in an inertial frame of reference can be observed in a uniformly accelerating frame of reference. Uniformly accelerating frames of reference produce event horizons at a distance $-c^2/g$. For example, a person who is standing can never see further than this distance below his feet.

By the way, is it true that a light beam *cannot* catch up with an observer in hyperbolic motion, if the observer has a sufficient distance advantage at the start?

Challenge 1044

* The functions appearing above are defined using the expressions from the footnote on page 208:

$$\operatorname{sech} y = \frac{1}{\cosh y} \quad \text{and} \quad \tanh y = \frac{\sinh y}{\cosh y} .\quad (157)$$

Acceleration changes colours

We saw above that a moving receiver sees different colours from the sender. This colour shift or Doppler effect was discussed above for inertial motion only. For accelerating frames the situation is even stranger: sender S and receiver R do not agree on colours even if they are at rest with respect to each other. Indeed, if light is emitted in the direction of the acceleration, the expression for the space-time interval gives

$$c^2 d\tau^2 = \left(1 + \frac{g_0 x}{c^2}\right)^2 dt^2 \quad (159)$$

in which g_0 is the proper acceleration of an observer located at $x = 0$. We can deduce in a straightforward way that

$$\frac{f_R}{f_S} = 1 - \frac{g_R h}{c^2} = 1 / \left(1 + \frac{g_S h}{c^2}\right) \quad (160)$$

where h is the rod distance between the source and the receiver, and where $g_S = g_0 / (1 + g_0 x_S / c^2)$ and $g_R = g_0 / (1 + g_0 x_R / c^2)$ are the proper accelerations measured at the x -coordinates of the source and at the detector. In short, the frequency of light decreases when light moves in the direction of acceleration. By the way, does this have an effect on the colour of trees along their vertical extension?

The formula usually given, namely

$$\frac{f_R}{f_S} = 1 - \frac{gh}{c^2} \quad , \quad (161)$$

is only correct to first approximation, and not exactly what was just found. In accelerated frames of reference, we have to be careful with the meaning of every quantity used. For everyday accelerations, however, the differences between the two formulae are negligible. Are you able to confirm this?

Can light move faster than c ?

What speed of light is measured by an accelerating observer? Using expression (161) above, an accelerated observer deduces that

$$v_{\text{light}} = c \left(1 + \frac{gh}{c^2}\right) \quad (162)$$

which is higher than c in the case when light moves in front or ‘above’ him, and lower than c for light moving behind or ‘below’ him. This strange result concerning the speed of light follows from the fact that in an accelerating frame of reference, even though all observers are at rest with respect to each other, clocks do *not* remain synchronized. This effect has also been confirmed by experiment. In other words, the speed of light is only constant when it is defined as $c = dx/dt$, and if dx and dt are measured with a ruler located at a point *inside* the interval dx and a clock read off *during* an instant inside the interval dt . If the speed of light is defined as $\Delta x / \Delta t$, or if the ruler defining distances or the clock measuring times is located away from the propagating light, the speed of light comes out to be different from c

for accelerating observers! For the same reason, turning around your axis at night leads to star velocities much higher than the speed of light.

Note that this result does not imply that signals or energy can be moved faster than c , as you may want to check for yourself.

Challenge 1112

In fact, all these difficulties are only noticeable for distances l that do not obey the relation $l \ll c^2/a$. This means that for an acceleration of 9.5 m/s^2 , about that of free fall, distances would have to be of the order of one light year, $9.5 \cdot 10^{12} \text{ km}$, in order to observe any sizable effects. In short, c is the speed of light relative to nearby matter only.

By the way, everyday gravity is equivalent to a constant acceleration. Why then don't distant objects, such as stars, move faster than light following expression (162)?

Challenge 8

What is the speed of light?

We have seen that the speed of light, as usually defined, is given by c only if either the observer is inertial or the observer measures the speed of light passing nearby, instead of light passing at a distance. In short, the speed of light has to be measured locally. But this request does not eliminate all subtleties.

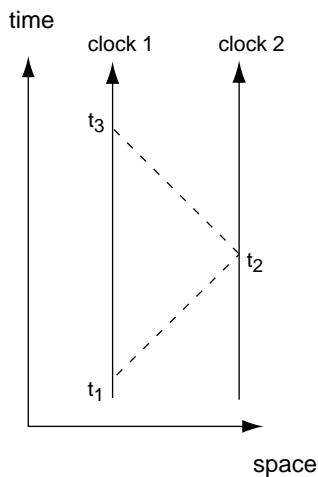

Figure 109 Clocks and the measurement of the speed of light as two-way velocity

An additional point is often forgotten. Usually, length is measured by the time it takes light to travel. In such a case the speed of light will obviously be constant. However, how does one check the constancy in the present case? One needs to eliminate length measurements. The simplest way to do this is to reflect light from a mirror. The constancy of the speed of light implies that if light goes up and down a short straight line, then the clocks at the two ends measure times given by

Ref. 218

$$t_3 - t_1 = 2(t_2 - t_1) \quad (163)$$

Here it was assumed that the clocks were synchronized according to the prescription on page 184. If the factor were not exactly two, the speed of light would not be constant. In fact, all experiments so far have yielded a factor of two within measurement errors.

This result is often expressed by saying that it is impossible to measure the *one-way velocity of light*; only the *two-way* velocity of light is measurable. Can you confirm

Challenge 25

this?

Limits on the length of solid bodies

An everyday solid object breaks when some part of it moves with more than the speed of sound c of that material with respect to some other part. * For example, when an object hits

* For glass and metals the (longitudinal) *speed of sound* is about 5.9 km/s for glass, iron or steel, and 4.5 km/s for gold; for lead about 2 km/s; for beryllium it is about 12.8 km/s. In comparison, the speed of sound is 1.5 km/s for rubber and water, about 1.1 km/s for most other liquids, and about 0.3 km/s for air and almost all gases, except helium, where it is 1.1 km/s. (All these values are at room temperature and standard pressure.)

the floor, its front end is stopped within a distance d ; therefore the object breaks at the latest when

$$\frac{v^2}{c^2} \geq \frac{2d}{l} . \quad (164)$$

We see that we can avoid the breaking of fragile objects by packing them into foam rubber – which increases the stopping distance – of roughly the same thickness as the object's size. This may explain why boxes containing presents are usually so much larger than their contents!

The fracture limit can also be written in a different way. To avoid breaking, the acceleration a of a solid body with length l must follow

$$la < c^2 , \quad (165)$$

where c is the speed of sound, which is the speed limit for the material parts of solids. Let us repeat the argument in relativity, introducing the speed of light instead of that of sound. Imagine accelerating the front of a *solid* body with some *proper* acceleration a . The back end cannot move with an acceleration α equal or larger than infinity, or if one prefers, it cannot move with more than the speed of light. A quick check shows that therefore the length l of a solid body must obey

$$l\alpha < c^2 , \quad (166)$$

where c is now the speed of light. The speed of light thus limits the size of solid bodies. For example, for 9.8 m/s^2 , the acceleration of a quality motor bike, this expression gives a length limit of 9.2 Pm, about a light year. Not a big restriction; most motor bikes are shorter.

However, there are other, more interesting situations. The highest accelerations achievable today are produced in particle accelerators. Atomic nuclei have a size of about 1 fm. Are you able to deduce at which energies they break when smashed together in an accelerator?*

Note that Galilean physics and relativity produce a similar conclusion: a limiting speed, be it that of sound or that of light, makes it impossible for solid bodies to be *rigid*. When we push one end of a body, the other end always moves a little bit later.

What does this mean for the size of elementary particles? Take two electrons at a distance d , and call their size l . The acceleration due to electrostatic repulsion then leads to an upper limit for their size given by

$$l < \frac{4\pi\epsilon_0 c^2 d^2 m}{e^2} . \quad (167)$$

The nearer electrons can get, the smaller they must be. The present experimental limit shows that the size is smaller than 10^{-19} m . Can electrons be point-like? We will come back to this issue during the study of quantum theory.

* However, inside a nucleus, the nucleons move with accelerations of the order of $v^2/r \approx \hbar^2/m^2 r^3 \approx 10^{31} \text{ m/s}^2$; this is one of the highest values found in nature.

Special relativity in four sentences

This section of our ascent of Motion Mountain is rapidly summarized.

- All free floating observers find that there is a perfect velocity in nature, namely a common maximum energy velocity, which is realized by massless radiation such as light or radio signals, or by neutrinos (provided they are indeed massless), but cannot be achieved by ordinary material systems.

- Therefore, even though space-time is the same for every observer, times and lengths vary from one observer to another, as described by the Lorentz transformations (87) and (88), and as confirmed by experiment.

- Collisions show that this implies that mass is concentrated energy, and that the total energy of a body is given by $E = \gamma mc^2$, as again confirmed by experiment.

- Applied to accelerated objects, these results lead to numerous counterintuitive consequences, such as the twin paradox, the appearance of event horizons and the appearance of short-lived tachyons in collisions.

In summary, special relativity shows that motion is relative, defined using the propagation of light, conserved, reversible and deterministic.

During our earlier exploration of Galilean physics, once we had defined the basic concepts of velocity, space and time, we turned our attention to gravitation. Since experiments have forced us to change these basic concepts, we now return to study gravitation in the light of these changes.



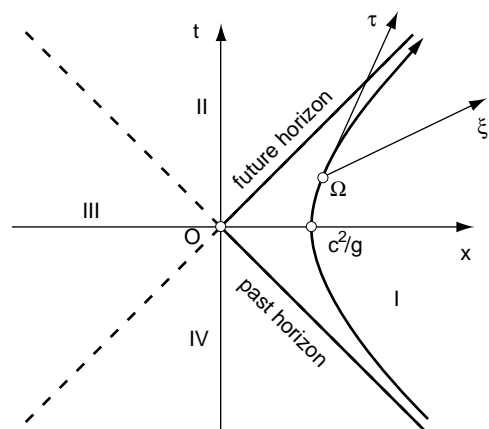

Figure 108 Do accelerated objects depart from inertial ones?

References

Aiunt enim multum legendum esse, non multa.
Plinius*

- 1 A beautiful book explaining physics and its many applications in nature and technology vividly and thoroughly is PAUL G. HEWITT, JOHN SUCHOCKI & LESLIE A. HEWITT, *Conceptual physical science*, Second Edition, 1999. Typeset in July 2002
A book famous for its passion for curiosity is RICHARD P. FEYNMAN, R.B. LEIGHTON & M. SANDS, *The Feynman lectures on physics*, Addison Wesley, 1977.
A lot on motion can be learned from quiz books. An good collection is JEAN-MARC LÉVY-LEBLOND, *La physique en questions - mécanique*, Vuibert, Paris, 1998, a translation from the Russian original.
Another excellent collection is YAKOV PERELMAN, *Oh, la physique*, Dunod, Paris, 2000, a translation from the Russian original. Cited on page 25, 100, 140.
- 2 A well-known principle in the social sciences states that given a question, for every possible answer, however weird it may seem, there is somebody – and often a whole group – who holds it as his opinion. One just has to go through literature to find out. This sociological ‘law of nature’ is discussed in ...
About group behaviour in general, see R. AXELROD, *The evolution of cooperation*, Harper Collins, 1984. The propagation and acceptance of ideas, such as those of physics, are also an example of human cooperation, with all its potential dangers and weaknesses. Cited on page 27.
- 3 All the known texts by Parmenides and Heraclitos can be found in J.P. DUMONT, *Les écoles présocratiques*, Folio – Gallimard, 1988. Views about the non-existence of motion have also been put forward by much more modern, and much more despicable authors, such as in 1710 by Berkeley. Cited on page 27. See page 457
- 4 An example of people worried by Zeno is given by WILLIAM MCLAUGHLIN, *Resolving Zeno’s paradoxes*, Scientific American pp. 66–71, November 1994. The actual argument was not about a hand slapping a face, but about an arrow hitting the target. See also reference 31. Cited on page 27.
- 5 For other interesting physical effects in everyday life, see also ERWEIN FLACHSEL, *Hundertfünfzig Physikrätsel*, Ernst Klett Verlag, 1985. The book also covers several clock puzzles, in puzzle numbers 126 to 128. Cited on page 28, 50.
- 6 A concise and informative introduction into the history of classical physics is given in the first chapter of the book by F.K. RICHTMEYER, E.H. KENNARD & J.N. COOPER, *Introduction to modern physics*, McGraw-Hill, New York, 1969. Cited on page 28.
- 7 A good overview over the arguments used to prove the existence of god from motion is given by MICHAEL BUCKLEY, *Motion and motion’s god*, Princeton University Press, 1971. The intensity of the battles waged around these failed attempts is one of the tragicomic chapters of history. Cited on page 29.
- 8 A good and fun book on behaviour change is the well-known text by R. BANDLER, *Using your brain for a change*, Real People Press, 1985. See also RICHARD BANDLER & JOHN GRINDER, *Frogs into princes – Neuro Linguistic Programming*, Eden Grove Editions, 1990. Cited on page 29, 32.

* ‘Read a lot, not anything.’ Ep. 7, 9, 15. Gaius Plinius Secundus (23 or 24, Novum Comum–79, Vesuve eruption), roman writer, especially famous for his large, mainly scientific work *Naturalis historia*, which has been translated and read for almost 2000 years.

- 9** A beautiful book about the mechanisms of human growth from the original cell to full size is LEWIS WOLPERT, *The triumph of the embryo*, Oxford University Press, 1991. Cited on page 29.
- 10** On the topic of grace and poise, see e.g. the numerous books on the Alexander technique, such as M. GELB, *Body learning – an introduction to the Alexander technique*, Aurum Press, 1981, and RICHARD BRENNAN, *Introduction to the Alexander Technique*, Little Brown and Company, 1996. Among others, the idea of the Alexander technique is to return to the situation that the muscles groups for sustention and those for motion are used only for their respective function, and not vice versa. Any unnecessary muscle tension, such as neck stiffness, is a waste of energy due to the use of sustention muscles for movement and of motion muscles for sustention. The technique teaches the way to return to the natural use of muscles.
- Motion of animals was discussed extensively already in the 17th century by G. BORELLI, *De motu animalium*, 1680. An example of a more modern approach is J.J. COLLINS & I. STEWART, *Hexapodal gaits and coupled nonlinear oscillator models*, *Biological Cybernetics* **68**, pp. 287–298, 1993. See also I. STEWART & M. GOLUBITSKY, *Fearful Symmetry*, Blackwell, 1992. Cited on page 30, 71.
- 11** The results on the development of children mentioned here and in the following have been drawn mainly from the studies initiated by Jean Piaget; for more details on child development, see the intermezzo following this chapter, on page 418. At vanbc.wimsey.com/chris/JPS/JPS.html one can find the web site maintained by the Jean Piaget Society. Cited on page 32, 40, 40.
- 12** A description of the reptile brain in comparison to the mammalian and the human one can be found in ... Cited on page 33.
- 13** The lower left corner movie can be reproduced on a computer after typing the following lines in the Mathematica software package: Cited on page 33, 33.

```
<< Graphics`Animation`
Nxpixels=72; Nypixels=54; Nframes=Nxpixels 4/3;
Nxwind=Round[Nxpixels/4]; Nywind=Round[Nypixels/3];
front=Table[Round[Random[]],{y,1,Nypixels},{x,1,Nxpixels}];
back =Table[Round[Random[]],{y,1,Nypixels},{x,1,Nxpixels}];
frame=Table[front,{nf,1,Nframes}];
Do[ If[ x>n-Nxwind && x<n && y>Nywind && y<2Nywind,
      frame[[n,y,x]]=back[[y,x-n+1]] ],
    {x,1,Nxpixels}, {y,1,Nypixels}, {n,1,Nframes}];
film=Table[ListDensityPlot[frame[[nf]], Mesh-> False,
      Frame-> False, AspectRatio-> N[Nypixels/Nxpixels],
      DisplayFunction-> Identity], {nf,1,Nframes}];
ShowAnimation[film]
```

But our motion detection system is much more powerful than the example shown in the lower left corners. The following, different movie makes the point.

```
<< Graphics`Animation`
Nxpixels=72; Nypixels=54; Nframes=Nxpixels 4/3;
Nxwind=Round[Nxpixels/4]; Nywind=Round[Nypixels/3];
front=Table[Round[Random[]],{y,1,Nypixels},{x,1,Nxpixels}];
back =Table[Round[Random[]],{y,1,Nypixels},{x,1,Nxpixels}];
frame=Table[front,{nf,1,Nframes}];
Do[ If[ x>n-Nxwind && x<n && y>Nywind && y<2Nywind,
      frame[[n,y,x]]=back[[y,x]] ],
    {x,1,Nxpixels}, {y,1,Nypixels}, {n,1,Nframes}];
film=Table[ListDensityPlot[frame[[nf]], Mesh-> False,
```

```

Frame-> False, AspectRatio-> N[Nypixels/Nxpixels],
DisplayFunction-> Identity], {nf, 1, Nframes}]
ShowAnimation[ film]

```

Similar experiments, e.g. using randomly changing random patterns, show that the eye perceives motion even in cases where all Fourier components of the image are practically zero; such image motion is called *drift-balanced* or *non-Fourier* motion. Several examples are presented in J. ZANKER, *Modelling human motion perception I: classical stimuli*, *Naturwissenschaften* **81**, pp. 156–163, 1994, and J. ZANKER, *Modelling human motion perception II: beyond Fourier motion stimuli*, *Naturwissenschaften* **81**, pp. 200–209, 1994.

- 14** An introduction into perception research is E. BRUCE GOLDSTEIN, *Perception*, Books/Cole, 5th edition, 1998. Cited on page [33](#).
- 15** All fragments from Heraclitos are from JOHN MANSLEY ROBINSON, *An introduction to early Greek philosophy*, Houghton Muffin 1968, chapter 5. Cited on page [34](#), [128](#).
- 16** An introduction to the story of classical mechanics which also destroys a few of the myths surrounding it, such as the idea that he could solve differential equations or that he introduced the expression $F = ma$, is given by CLIFFORD A. TRUESDELL, *Essays in the history of mechanics*, Springer, 1968. Cited on page [37](#), [89](#), [103](#).
- 17** An introduction to Newton the alchemist are the two books by BETTY JO TEETER DOBBS, *The foundations of Newton's alchemy*, 1983, and *The Janus face of genius*, Cambridge University Press, 1992. Newton is found to be a sort of highly intellectual magician, desperately looking for examples of processes where god interacts with the material world. An intense but tragic tale. A good overview is provided by R.G. KEESING, *Essay Review: Newton's Alchemy*, *Contemporary Physics* **36**, pp. 117–119, 1995.
- Newton's infantile theology, typical for god seekers who grew up without a father, can be found in the many books summarizing the exchanges between Clarke, his secretary, and Leibniz, Newton's rival to fame. Cited on page [37](#).
- 18** Almost all textbooks, both for schools and for university start with the definition of space and time. Even otherwise excellent relativity textbooks cannot avoid this habit, even those which introduce the now standard k-calculus (which is in fact the approach mentioned here). Cited on page [38](#).
- 19** C. LIU, Z. DUTTON, C.H. BEHROOZI & L.V. HAN, *Observation of coherent optical storage in an atomic medium using halted light pulses*, *Nature* **409**, pp. 490–493, 2001. There is also a comment of the paper by E.A. CORNELL, *Stopping light in its track*, **409**, pp. 461–462, 2001. However, despite the claim, the light pulses of course have *not* been halted. Can you give at least two reasons without even reading the paper, and maybe a third after reading it?
- The work was an improvement of the previous experiment where a group velocity of light of 17 m/s had been achieved, in an ultracold gas of sodium atoms, at nanokelvin temperatures. This was reported by LENE VESTERGAARD HAU, S.E. HARRIS, ZACHARY DUTTON & CYRUS H. BERTOZZI, *Light speed reduction to 17 meters per second in an ultracold atomic gas*, *Nature* **397**, pp. 594–598, 1999. Cited on page [39](#), [186](#).
- 20** &, *Biologie in Zahlen*, Spektrum Verlag, 1998. Cited on page [39](#).
- 21** Two jets with that speed have been observed by I.F. MIRABEL & L.F. RODRÍGUEZ, *Nature* **371**, pp. 46–48, 1994, as well as the comments on p. 18. Cited on page [39](#).
- 22** The clocks in our brain are described in ...The clocks in our body are described in ... Cited on page [42](#).
- 23** This has been shown among others by the work of Anna Wierzbicka mentioned in more detail in the intermezzo following this chapter, on page [426](#). Also the passionate bestseller by the Chomskian author STEVEN PINKER, *The language instinct – How the mind creates language*, Harper Perennial, 1994, discusses issues related to this matter, refuting amongst others

Challenge 110

This is a section of the freely downloadable e-textbook

Motion Mountain

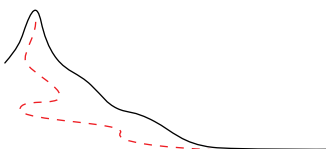

Hiking beyond space and time along the concepts of modern physics

available at
www.motionmountain.org

Copyright © 1997, 1998, 1999, 2000, 2001, 2002 by Christoph Schiller

To the kind reader

In exchange for getting this section for free, I ask you for a short email on some of the following:

- Which page was boring?
- Did you find any mistakes?
- What else were you expecting?
- What was hard to understand?

Of course, any other suggestion is welcome. This section is part of a physics text written over many years. The text lives and grows through the feedback from its readers, who help to improve and to complete it. For a particularly useful contribution (send it in english, italian, dutch, german, spanish, portuguese, or french) you will be mentioned in the foreword of the text, or receive a small reward, or both.

Enjoy!

Christoph Schiller
cs@motionmountain.org

Challenge 93

- on page 63 the often repeated false statement that the *Hopi* language is an exception. Cited on page 42.
- 24** Galileo used a water tube pointing in a bucket which he kept closed with his thumb. To start the stopwatch, he removed the thumb, to stop it, he put it back on. The volume of water in the bucket then gave him a measure of the time interval. Cited on page 43.
- 25** Aristotle rejects the idea of the flow of time in ... Cited on page 43.
- 26** Perhaps the most informative of the books about the ‘arrow of time’ is ..
A typical conference proceeding is J.J. HALLIWELL, J. PÉREZ-MERCADER & W.H. ZUREK, *Physical origins of time asymmetry*, Cambridge University Press, 1994. Cited on page 43.
- 27** R. DOUGHERTY & M. FOREMAN, *Banach-Tarski decompositions using sets with the property of Baire*, Journal of the American Mathematical Society **7**, pp. 75–124, 1994. See also ALAN L.T. PATERSON, *Amenability*, American Mathematical Society, 1998, and ROBERT M. FRENCH, *The Banach-Tarski theorem*, The Mathematical Intelligencer **10**, pp. 21–28, 1998. Finally, there are the books by B.R. GERLBAUM & J.M.H. OLMSTED, *Counterexamples in analysis*, Holden-Day, 1964, and *Theorems and counterexamples in mathematics*, Springer Verlag. Cited on page 49.
- 28** About the shapes of salt water bacteria, see the corresponding section in the interesting book by BERNARD DIXON, *Power unseen – how microbes rule the world*, W.H. Freeman, New York, 1994. The book has about 80 sections, in which as many microorganisms are vividly presented. Cited on page 49.
- 29** There is a whole story behind the variations of g . It can be read in CHUJI TSUBOI, *Gravity*, Allen & Unwin, 1979, or in WOLFGANG TORGE, *Gravimetry*, de Gruyter, 1989, or in MILAN BURČA & KAREL PĚC, *The gravity field and the dynamics of the earth*, Springer, 1993. The variation of the height of the soil by around 0.3 m due to the moon is one of the more interesting effects described by these investigations. Cited on page 52, 93.
- 30** This was discussed in the Frankfurter Allgemeine Zeitung, 2.8.1997, at the time of the world athletics championship. The values are for the fastest part of a 100 m sprinter; the exact values cited were called the running speed world records in 1997, and were given as 12.048 m/s = 43.372 km/h by Ben Johnson for men, and 10.99 m/s = 39.56 km/h for women.
The 1998 world record for ball juggling is nine balls. Cited on page 52.
- 31** The arguments of Zeno can be found in ARISTOTLE, *The ...*, which can be found translated in almost any language. Cited on page 54, 215.
- 32** Professor to student: What is the derivative of velocity? Acceleration! What is the derivative of acceleration? I don’t know. *Jerk!* The fourth, fifth and sixth derivatives of position are sometimes called *snap*, *crackle* and *pop*. Cited on page 55.
- 33** Etymology can be a fascinating topic, e.g. when it discovers the origin of the genus of the German word ‘Weib’ (‘woman’, related to English ‘wife’). It was discovered, via a few Thocharian texts – an extinct indoeuropean language from a region inside modern China – to mean originally ‘shame’. It was used for the female genital region in an expression meaning ‘place of shame’. With time, this expression became to mean ‘woman’ in general, while being shortened to the second term only. This story was discovered by the German linguist Klaus T. Schmidt; it explains in particular why the word is not feminine but neutral, i.e. why it uses the article ‘das’ instead of ‘die’. Julia Simon, private communication.
Etymology can also be simple and plain fun, for example when one discovers that ‘testimony’ and ‘testicle’ have the same origin; indeed in Latin the same word ‘testis’ was used for both concepts. Cited on page 56, 61.

- 34** An overview of the latest developments is given by J. T. ARMSTRONG, D. J. HUNTER, K. J. JOHNSTON & D. MOZURKEWICH, *Stellar optical interferometry in the 1990s*, Physics Today pp. 42–49, May 1995. More than 100 stellar diameters have been measured in 1995, and several new powerful instruments are being planned. Cited on page [57](#).
- 35** A good biology textbook on growth is ... Cited on page [57](#).
- 36** This is discussed for example in C. L. STONG, *The amateur scientist – how to supply electric power to something which is turning*, Scientific American pp. 120–125, 1970. It also discusses how to make a still picture of something rotating simply using a few prisms, the so called *Dove prisms*. Other examples of attaching something to a rotating body are given by E. RIEFLIN, *Some mechanisms related to Dirac's strings*, American Journal of Physics **47**, pp. 379–381, 1979. By the way, the real reason for the impossibility of wheels turns out to be that it is impossible to make an *axis* using a single piece of skin. Cited on page [57](#).
- 37** JAMES A. YOUNG, *Tumbleweed*, Scientific American **264**, pp. 82–87, March 1991. The tumbleweed is in fact quite rare, except in in Hollywood westerns, where all directors feel obliged to give it a special appearance. Cited on page [58](#).
- 38** The first experiments to prove the rotation of the flagella were by M. SILVERMAN & M. I. SIMON, *Flagellar rotation and the mechanism of bacterial motility*, Nature **249**, pp. 73–74, 1974. For some pretty pictures of the molecules involved, see K. NAMBA, *A biological molecular machine: bacterial flagellar motor and filament*, Wear **168**, pp. 189–193, 1993. The present record speed of rotation, 1700 rotations per second, is reported by Y. MAGARIYAMA, S. SUGIYAMA, K. MURAMOTO, Y. MAEKAWA, I. KAWAGISHI, Y. IMAE & S. KUDO, *Very fast flagellar rotation*, Nature **371**, p. 752, 1994.
More on bacteria can be learned from DAVID DUSENBERY, *Life at a small scale*, Scientific American Library, 1996. Cited on page [58](#).
- 39** There is also the beautiful book by PENELOPE FARRANT, *Colour in Nature*, Blandford, 1997. Cited on page [59](#).
- 40** The laws of cartoon physics can be found in various places on the internet. Cited on page [59](#).
- 41** For the curious, an overview of the illusions used in the cinema and in television, which lead to some of the strange behaviour of images mentioned above, is given in BERNARD WILKIE, *The technique of special effects in television*, Focal Press, 1993, and his other books, or in the *Cinefex* magazine. Cited on page [60](#).
- 42** GIUSEPPE FUMAGALLI, *Chi l'ha detto?*, Hoepli, Milano, 1983. The sentence is also the motto of the cities of the Hansa. Cited on page [60](#), [107](#), [113](#).
- 43** For the role and chemistry of adenosinetriphosphate (ATP) in cells and in living beings, see ... Cited on page [65](#).
- 44** A picture of this unique clock can be found in the article by A. GARRETT, *Perpetual motion – a delicious delirium*, Physics World pp. 23–26, December 1990. Cited on page [65](#).
- 45** A Shell study estimates the world's total energy consumption in 2000 to be 500 EJ. The US department of energy estimates it to be around 416 EJ. We took the lower value here. A discussion and a breakdown into electricity usage (14 EJ) and other energy forms, with variations per country, can be found in S. BENKA, *The energy challenge*, Physics Today **55**, p. 38–39, April 2002, and in E. J. MONITZ & M. A. KENDERDINE, *Meeting energy challenges: technology and policy*, Physics Today **55**, p. 40–46, April 2002. Cited on page [66](#).
- 46** For an overview, see the paper by J. F. MULLIGAN & H. G. HERTZ, *An unpublished lecture by Heinrich Hertz: 'On the energy balance of the earth'*, American Journal of Physics **65**, pp. 36–45, 1997. Cited on page [67](#).
- 47** For a beautiful photograph of this feline feat, see the cover of Nature ... Cited on page [70](#).

- 48 NATTHI L. SHARMA, *A new observation about rolling motion*, European Journal of Physics **17**, pp. 353–356, 1996. Cited on page 70.
- 49 SERGE GRACOVETSKY, *The spinal engine*, Springer Verlag, 1990. Cited on page 71.
- 50 THOMAS HEATH, *Aristarchus of Samos – the ancient Copernicus*, Dover, 1981, reprinted from the original 1913 edition. Aristarchos' treaty is given in Greek and English. Aristarchos was the first proposer of the heliocentric system. Aristarchos had measured the length of the day (in fact, by determining the number of days per year) to the astonishing precision of less than one second. This excellent book also gives an overview of Greek astronomy before Aristarchos, explained in detail for each Greek thinker. Aristarchos' text is also reprinted in ARISTARCHOS, *On the sizes and the distances of the sun and the moon*, ca. 280 BCE in MICHAEL J. CROWE, *Theories of the world from antiquity to the Copernican revolution*, Dover, 1990, especially on pp. 27–29. Cited on page 72, 169.
- 51 An overview of the effects of the Coriolis acceleration $\mathbf{a} = -2\boldsymbol{\omega} \times \mathbf{v}$ in the rotating frame is given by EDWARD A. DESLOGE, *Classical mechanics*, Volume 1, John Wiley & Sons, 1982. Even the *gulf stream*, the current of warm water flowing from the caribbean to the north sea, is influenced by it. Cited on page 73.
- 52 The influence of the Coriolis effect on icebergs was studied most thoroughly by the swedish physicist turned oceanographer Walfrid Ekman (1874–1954); The topic was suggested by the great explorer Fridtjof Nansen, who also made the first observations. In his honour, one speaks of Ekman layer, Ekman transport, and Ekman spirals. Any text on oceanography or physical geography will tell more about it. Cited on page 73.
- 53 The original publication is by A.H. SHAPIRO, *Bath-tub vortex*, Nature **196**, pp. 1080–1081, 1962. He also produced two movies of the experiment. The experiment has been repeated many times in the northern and in the southern hemisphere, where the water drains clockwise; the first southern hemisphere test was L.M. TREFETHEN & al., *The bath-tub vortex in the southern hemisphere*, Nature **201**, pp. 1084–1085, 1965. A complete literature list is found in the letters to the editor of the American Journal of Physics **62**, p. 1063, 1994. Cited on page 73, 73.
- 54 The calculation of the period of Foucault's pendulum ... Cited on page 74.
- 55 The tricks are explained by H. RICHARD CRANE, *Short Foucault pendulum: a way to eliminate the precession due to ellipticity*, American Journal of Physics **49**, pp. 1004–1006, 1981, and particularly in H. RICHARD CRANE, *Foucault pendulum wall clock*, American Journal of Physics **63**, pp. 33–39, 1993. Cited on page 74.
- 56 R. ANDERSON, H.R. BILGER & G.E. STEDMAN, *The Sagnac-effect: a century of earth-rotated interferometers*, American Journal of Physics **62**, pp. 975–985, 1994.
See also the clear and extensive paper by G.E. STEDMAN, *Ring laser tests of fundamental physics and geophysics*, Reports on progress of physics **60**, pp. 615–688, 1997. Cited on page 75.
- 57 About the length of the day, see the maia.usno.navy.mil web site, or the books by K. LAMBECK, *The earth's variable rotation: geophysical causes and consequences*, Cambridge University Press, 1980, and by W.H. MUNK & G.J.F. MACDONALD, *The rotation of the earth*, Cambridge University Press, 1960. Cited on page 75, 94.
- 58 One example of data is the one by C.P. SONETT, E.P. KVALE, A. ZAKHARIAN, M.A. CHAN & T.M. DEMKO, *Late proterozoic and paleozoic tides, retreat of the moon, and rotation of the earth*, Science **273**, pp. 100–104, 5 July 1996. They deduce from tidal sediment analysis that days were only 18 to 19 hours long in the Proterozoic, i.e. 900 million years ago; they assume that the year was 31 million seconds long all along. Cited on page 75.

- 59 The motion of the earth's axis in the last ten years is shown on the mentioned maia.usno.navy.mil web site. The International Latitude Service founded by Küstner, is now part of the International Earth Rotation Service; more information can be found on the www.iers.org web site. The latest idea is that the circular component of the polar motion, which in the US is called 'Chandler wobble' after the scientist who has expanded on the original discovery by Küstner, is due by two thirds to fluctuations of the ocean pressure at the bottom of the oceans and by one third due to pressure changes in the atmosphere of the earth, as explained by R.S. GROSS, *The excitation of the Chandler wobble*, Geophysical Physics Letters **27**, p. 2329, 1st August 2000. Cited on page 76.
- 60 For more information about Alfred Wegener, read ...; about plate tectonics, see the www.scotese.com web site. On earthquakes, see the www.geo.ed.ac.uk/quakexe/quakes web site. On volcanoes, see the vulcan.wr.usgs.gov and www.dartmouth.edu/~volcano/ web sites. Cited on page 76.
- 61 The rotation and history of the solar system ... Cited on page 75.
- 62 J.D. HAYS, J. IMBRIE & N.J. SHACKLETON, *Variations in the earth's orbit: pacemaker of the ice ages*, Science **194**, pp. 1121–1132, 1976. They did this by literally digging in the mud which covers the ocean floor in certain places. Note that the web is full of information on the ice ages. Just look up Milankovitch in a search engine. Cited on page 78.
- 63 ROBERTA HUMPHREYS & JEFFREY LARSEN, *The sun's distance above the galactic plane*, Astronomical Journal **110**, pp. 2183–2188, November 1995. Cited on page 78.
- 64 C.L. BENNET, M.S. TURNER & M. WHITE, *The cosmic rosetta stone*, Physics Today **50**, pp. 32–38, November 1997. Cited on page 79.
- 65 The equilibrium of ships, so important in car ferries, is an interesting part of ship building; an introduction is given by ... Cited on page 80.
- 66 K.R. WENINGER, B.P. BARBER & S.J. PUTTERMAN, *Pulsed Mie scattering measurements of the collapse of a sonoluminescing bubble*, Physical Review Letters **78**, pp. 1799–1802, 1997. Cited on page 80.
- 67 On <http://www.sff.net/people/geoffrey.landis/vacuum.html> one can read a description of what happened. See also the <http://www.sff.net/people/geoffrey.landis/ebullism.html> and http://imagine.gsfc.nasa.gov/docs/ask_astro/answers/970603.html web sites. Cited on page 80.
- 68 The smallest distances are probed in particle accelerators; the distance can be determined from the energy of the particle beam. Cited on page 50.
- 69 Long jump data and literature can be found in three articles all entitled *Is a good long jumper a good high jumper?*, in the American Journal of Physics **69**, pp. 104–105, 2001. In particular, world class long jumpers run at 9.35 ± 0.15 m/s, with vertical takeoff speeds of 3.35 ± 0.15 m/s, giving takeoff angles of about (only) 20° . A new technique for achieving higher takeoff angles would allow to increase the world long jump record dramatically. Cited on page 52.
- 70 This and many other physics surprises are described in the beautiful lecture script by JOSEF ZWECK, *Physik im Alltag*, Skript zur Vorlesung im WS 1999/2000 der Universität Regensburg. Cited on page 79, 81.
- 71 R. MCN. ALEXANDER, *Leg design and jumping technique for humans, other vertebrates and insects*, Philosophical Transactions of the Royal Society in London B **347**, pp. 235–249, 1995. Cited on page 82.
- 72 JIM W. GLASHEEN & THOMAS A. MCMAHON, *A hydrodynamic model of locomotion in the basilisk lizard*, Nature **380**, pp. 340–342, For pictures, see also New Scientist p. 18, 30 March 1996, or Scientific American pp. 48–49, September 1997, or the http://rjf2.biol.berkeley.edu/FullLab/FL_Personnel/J_Glasheen/J_Glasheen.html web site.

- Several shore birds also have the ability to run over water, using the same mechanism. Cited on page 82.
- 73** A. FERNANDEZ-NIEVES & F.J. DE LAS NIEVES, *About the propulsion system of a kayak and of Basiliscus basiliscus*, *European Journal of Physics* **19**, pp. 425–429, 1998. Cited on page 83.
- 74** The story is told in M. NAUENBERG, *Hooke, orbital motion, and Newton's Principia*, *American Journal of Physics* **62**, 1994, pp. 331–350. Cited on page 84.
- 75** More details are given by D. RAWLINS, in *Doubling your sunsets or how anyone can measure the earth's size with wristwatch and meter stick*, *American Journal of Physics* **47**, 1979, pp. 126–128. Another simple measurement of the earth radius, using only a sextant, is given by R. O'KEEFE & B. GHAVIMI-ALAGHA, in *The world trade center and the distance to the world's center*, *American Journal of Physics* **60**, pp. 183–185, 1992. Cited on page 84.
- 76** More details on astronomical distance measurements can be found in the beautiful little book by A. VAN HELDEN, *Measuring the universe*, University of Chicago Press, 1985, and in NIGEL HENBEST & HEATHER COOPER, *The guide to the galaxy*, Cambridge University Press, 1994. Cited on page 84.
- 77** A lot of details can be found in M. JAMMER, *Concepts of mass in classical and modern physics*, reprinted by Dover, 1997, and in *Concepts of force, a study in the foundations of mechanics*, Harvard University Press, 1957. These eclectic and thoroughly researched texts provide numerous details and explain various philosophical viewpoints, but lack clear statements and conclusions on the accurate description of nature, and thus are not of help on fundamental issues.
- Jean Buridan (ca. 1295–ca. 1366) criticizes the distinction of sublunar and translunar motion in his book *De Caelo*, one of his numerous works. Cited on page 85.
- 78** D. TOPPER & D.E. VINCENT, *An analysis of Newton's projectile diagram*, *European Journal of Physics* **20**, pp. 59–66, 1999. Cited on page 85.
- 79** This is explained for example by D.K. FIRPIĆ & I.V. ANIÇIN, *The planets, after all, may run only in perfect circles – but in the velocity space!*, *European Journal of Physics* **14**, pp. 255–258, 1993. Cited on page 97.
- 80** About the measurement of spatial dimensions via gravity, see ... Cited on page 88.
- 81** There are many books explaining the origin of the precise shape of the earth, such as the pocket book S. ANDERS, *Weil die Erde rotiert*, Verlag Harri Deutsch, Thun, Frankfurt am Main, 1985. Cited on page 88.
- 82** The shape of the earth is described most precisely with the World Geodetic System. For an extensive presentation of its background and its details, see the <http://www.eurocontrol.be/projects/eatchip/wgs84/start.html> web site.
- See also the web site of the *International Earth Rotation Service* at <http://hpiers.obspm.fr>. Cited on page 88.
- 83** W.K. HARTMAN, R.J. PHILLIPS & G.J. TAYLOR, editors, *Origin of the Moon*, Lunar and Planetary Institute, Houston, 1986. Cited on page 90.
- 84** DIETRICH NEUMANN, *Physiologische Uhren von Insekten – Zur Ökophysiologie lunarperiodisch kontrollierter Fortpflanzungszeiten*, *Naturwissenschaften* **82**, pp. 310–320, 1995. Cited on page 90.
- 85** The origin of the duration of the menstrual cycle is not yet settled; however, there are explanations on how it gets synchronized with other cycles. For a general explanation see ARKADY PIKOVSKY, MICHAEL ROSENBLUM & JÜRGEN KURTHS, *Synchronization: a Universal Concept in Nonlinear Science*, Cambridge University Press, New York, 2002. Cited on page 90.

- 86** J. LASKKAR, F. JOUTEL & P. ROBUTEL, *Stability of the earth's obliquity by the moon*, Nature **361**, pp. 615–617, 1993. However, the question is not completely settled, and other opinions exist. Cited on page [90](#).
- 87** See for example the discussion by J.J. LISSAUER, *It is not easy to make the moon*, Nature **389**, pp. 327–328, 1997. Cited on page [91](#).
- 88** NEIL F. COMINS, *What if the moon did not exist? – Voyages to earths that might have been*, Harper Collins, 1993. Cited on page [91](#).
- 89** PAUL A. WIEGERT, KIMMO A. INNANEN & SEPPO MIKKOLA, *An asteroidal companion to the earth*, Nature **387**, pp. 685–686, 12 June 1997, together with the comment on pp. 651–652. Cited on page [92](#).
- 90** SIMON NEWCOMB, *Astronomical Papers of the American Ephemeris* **1**, p. 472, 1882. Cited on page [93](#).
- 91** A beautiful introduction is the classic G. FALK & W. RUPPEL, *Mechanik, Relativität, Gravitation – ein Lehrbuch*, Springer Verlag, Dritte Auflage, 1983. Cited on page [93](#).
- 92** J. SOLDNER, *Berliner Astronomisches Jahrbuch auf das Jahr 1804*, 1801, p. 161. Cited on page [95](#).
- 93** The equality was first tested with precision by ROLAND VON EÖTVÖS, *Annalen der Physik & Chemie* **59**, p. 354, 1896, and by R. VON EÖTVÖS, V. PEKÁR & E. FEKETE, *Beiträge zum Gesetz der Proportionalität von Trägheit und Gravität*, *Annalen der Physik* **4**, Leipzig **68**, pp. 11–66, 1922. He found agreement to 5 parts in 10^9 . More experiments were performed by P.G. ROLL, R. KROTKOW & R.H. DICKE, *The equivalence of inertial and passive gravitational mass*, *Annals of Physics (NY)* **26**, pp. 442–517, 1964, one of the most interesting and entertaining research articles in experimental physics, and by V.B. BRAGINSKY & V.I. PANOV, *Soviet Physics - JETP* **34**, pp. 463–466, 1971. Modern results, with errors less than one part in 10^{12} , are by Y. SU & al., *New tests of the universality of free fall*, *Physical Review D* **50**, pp. 3614–3636, 1994. Several experiments have been proposed to test the equality in space to less than one part in 10^{16} . Cited on page [96](#).
- 94** The issue is explained in A.E. CHUBYKALO & S.J. VLAEV, *Theorem on the proportionality of inertial and gravitational masses in classical mechanics*, *European Journal of Physics* **19**, pp. 1–6, 1998. Cited on page [96](#).
- 95** See L. HODGES, *Gravitational field strength inside the earth*, *American Journal of Physics* **59**, pp. 954–956, 1991. Cited on page [98](#).
- 96** P. MOHAZZABI & M.C. JAMES, *Plumb line and the shape of the earth*, *American Journal of Physics* **68**, pp. 1038–1041, 2000. Cited on page [99](#).
- 97** From NEIL DE GASSE TYSON, *The universe down to earth*, Columbia University Press, 1994. Cited on page [99](#).
- 98** GERALD QUINLAN, *Nature* **363**, pp. 18–19, 1993. See also reference [122](#). Cited on page [99](#).
- 99** See ROBERT MATTHEWS, *Not a snowball's chance ...*, *New Scientist* 12 July 1997, pp. 24–27. The original claim is by LOUIS A. FRANK, J.B. SIGWARTH & J.D. CRAVEN, *On the influx of small comets into the earth's upper atmosphere*, parts I and II *Geophysical Research Letters* **13**, pp. 303–306, pp. 307–310, 1986. The latest observations seem to disprove the claim. Cited on page [99](#).
- 100** The ray form is beautifully explained by J. EVANS, *The ray form of Newton's law of motion*, *American Journal of Physics* **61**, pp. 347–350, 1993. Cited on page [100](#).
- 101** G.J. SUSSMAN & J. WISDOM, *Chaotic Evolution of the Solar System*, *Science* **257**, pp. 56–62, 1992. Cited on page [100](#).

- 102** GEORGE-LOUIS LESAGE, *Lucrèce Newtonien*, Nouveaux mémoires de l'academie royale des sciences et belles letters pp. 404–431, 1747. Cited on page 100.
- 103** Knowledge is power. Time is money. Now, power is defined as work per time. Inserting the previous equations and transforming, one gets:

$$\text{money} = \frac{\text{work}}{\text{knowledge}} \quad ; \quad (168)$$

in other words, the less you know, the more, money you make. That is why scientists don't make a lot of money. Cited on page 103.

- 104** D. HESTENES, M. WELLS & G. SWACKHAMER, *Force concept inventory*, Physics Teacher **30**, pp. 141–158, 1982. They have developed tests checking the understanding of the concept of physical force in students which have attracted a lot of attention in the field of physics didactics. Cited on page 103.
- 105** See M. HIRANO & K. SHINJO, ..., Physical Review Letters **78**, pp. 1448–1451, 1997. See also the discussion of their results by SERGE FAYEULLE, *Superlubricity: when friction stops*, Physics World pp. 29–30, May 1997. Cited on page 104.
- 106** C.D. AHRENS, *Meteorology today: an introduction to the weather, climate, and the environment*, West Publishing Company, St. Paul, 1991. Cited on page 106.
- 107** This topic is discussed with lucidity by J.R. MUREIKA, *What really are the best 100 m performances?*, Athletics: Canada's National Track and Field Running Magazine, July 1997. It can also be found under <http://xxx.lanl.gov/physics/9705004> together with other papers on similar topics by the same author. Cited on page 106.
- 108** F.P. BOWDEN & D. TABOR, *The friction and lubrication of solids*, Oxford University Press, Part I, revised edition, 1954, and part II, 1964. Cited on page 106.
- 109** The test of randomness can be found in the text ...The topic has many philosophical implications, discussed e.g. by ...Cited on page 109.
- 110** For one aspect of the issue, see for example the book by BERT HELLINGER, *Zweierlei Glück*, Carl Auer Systeme Verlag, 1997. The author explains how to live serenely and with the highest possible responsibility of one's actions, by reducing entanglements with the destiny of others. He describes a simple and powerful technique to realize this goal.
For another aspect, see the text by peace Nobel price winner AUNG SAN SUU KYI..., *Freedom from fear*, ...Cited on page 111.
- 111** HENRIK WALTER, *Neurophilosophie der Willensfreiheit*, ...Cited on page 111.
- 112** The beautiful story of the south pointing carriage is told in Appendix B of JAMES FOSTER & J.D. NIGHTINGALE, *A short course in general relativity*, Springer Verlag, 2nd edition 1998. Such carriages have existed in China, as told (as usual) by Joseph Needham, but their construction is unknown. The carriage described by Foster and Nightingale is the one reconstructed in 1947 by George Lancaster, a British engineer. Cited on page 114.
- 113** See for example Z. GHAHRAMANI, *Building blocks of movement*, Nature **407**, pp. 682–683, 2000. Researchers in robot control are also interested in such topics. Cited on page 114.
- 114** G. GUTIERREZ, C. FEHR, A. CALZADILLA & D. FIGUEROA, *Fluid flow up the wall of a spinning egg*, American Journal of Physics **66**, pp. 442–445, 1998. Cited on page 114.
- 115** A historical account is given in WOLFGANG YOURGRAY & STANLEY MANDELSTAM, *Variational principles in dynamics and quantum theory*, Dover, 1968. Cited on page 116, 122.
- 116** MAX PÄSLER, *Prinzipie der Mechanik*, Walter de Gruyter & Co., 1968. Cited on page 120.
- 117** The relations between the possible Lagrangians is studied by ...Cited on page 120.

- 118** G.B. WEST, J.H. BROWN & B.J. ENQUIST, *A general model for the origin of allometric scaling laws in biology*, *Science* **276**, pp. 122–126, 4 April 1997, with a comment on page 34 of the same issue. The rules governing branching properties of blood vessels, of lymph systems, and of vessel systems in plants are explained. About plants, see also the paper by the same group in the 1999, August 12th issue of *Nature*. Cited on page [126](#).
- 119** J.R. BANAVAR & A. RINALDO, *Nature* 13 May 1999. Cited on page [127](#).
- 120** J.A. MOORE, *An innovation in physics instruction for nonscience majors*, *American Journal of Physics* **46**, pp. 607–612, 1978. Cited on page [122](#).
- 121** See e.g. ALAN P. BOSS, *Extrasolar planets*, *Physics Today* September 1996, pp. 32–38. The most recent information can be found at the ‘Extrasolar Planet Encyclopaedia’ maintained at <http://www.obspm.fr/planets> by Jean Schneider at the Observatoire de Paris. Cited on page [125](#).
- 122** A good review article is the one by DAVID W. HUGHES, *Comets and Asteroids*, *Contemporary Physics* **35**, pp. 75–93, 1994. Cited on page [126](#), [224](#).
- 123** A review on the fascinating mechanisms at the basis of the heart beat is given by the text being written by A. BABLOYANTZ, ... , Cited on page [163](#).
- 124** See e.g. B. BOWER, *A child’s theory of mind*, *Science News* **144**, pp. 40–41. Cited on page [129](#).
- 125** U. Niederer/ *The maximal kinematical invariance group of the free Schrödinger equation*, *Helvetica Physica Acta* **45**, pp. 802–810, 1972. See also the introduction by O. JAHN & V.V. SREEDHAR, *The maximal invariance group of Newton’s equations for a free point particle*, <http://arxiv.org/abs/math-ph/0102011>. Cited on page [135](#).
- 126** The story is told in the interesting biography of Einstein by A. PAIS, ‘*Subtle is the Lord...*’ – *The science and the life of Albert Einstein*, Oxford University Press, 1982. Cited on page [136](#).
- 127** M. AUSLOOS, *Proceedings of the Royal Society in London A* **400**, pp. 331–350, 1985. Cited on page [141](#).
- 128** T.A. MCMAHOB & J. TYLER BONNER, *Form und Leben – Konstruktion vom Reißbrett der Natur*, Spektrum Verlag, 1985. For jumps of an animal of mass m the necessary energy E is given as $E = mgh$, and the work available to a muscle is roughly speaking proportional to its mass $W \sim m$. Thus one gets that the height h is independent of the mass of the animal. In other words, the specific mechanical energy of animals is around 1.5 ± 0.7 J/kg. Cited on page [143](#).
- 129** A simple article explaining the tallness of trees is A. MINEYEV, *Trees worthy of Paul Bunyan*, *Quantum*, pages 4–10, January–February 1994. (Paul Bunyan is a mythical giant lumberjack who is the hero of the frontier pioneers in the beginning of United States history.) Note that the transport of liquids in trees poses no limits on their height, since water is pumped up along tree stems (except in spring, when it is pumped up from the roots) by evaporation from the leaves. This works almost without limits because water columns, when nucleation is carefully avoided, can be put under tensile stresses of over 100 bar, corresponding to 1000 m. Cited on page [144](#).
- 130** Such information can be taken from the excellent overview article by M.F. ASHBY, *On the engineering properties of materials*, *Acta Metallurgica* **37**, pp. 1273–1293, 1989. The article explains the various general criteria which determine the selection of materials, and gives numerous tables to guide the selection. Cited on page [144](#).
- 131** For a photograph of a single Barium atom – named Astrid – see HANS DEHMELT, *Experiments with an isolated subatomic particle at rest*, *Reviews of Modern Physics* **62**, pp. 525–530, 1990, for an earlier photograph of a Barium ion, see W. NEUHAUSER, M. HOHENSTATT & P.E. TOSCHEK, *Localized visible Ba⁺ mono-ion oscillator*, *Physical Review A* **22**, pp. 1137–1140, 1980. Cited on page [145](#).

- 132** Holograms of atoms have been produced first by Hans-Werner FINK & al., ..., Physical Review Letters **67**, pp. 1543–1546, 1991. Cited on page **145**.
- 133** A single atom laser has been built in 1994 by K. AN & al., Physical Review Letters November-December 1994. Cited on page **145**.
- 134** See for example C. SCHILLER, A.A. KOOMANS, T.L. VAN ROOY, C. SCHÖNENBERGER & H.B. ELSWIJK, *Decapitation of tungsten field emitter tips during sputter sharpening*, Surface Science Letters **339**, pp. L925–L930, 1996. Cited on page **146**.
- 135** Good pictures of atoms taken by atomic force microscopes can be found in HERMAN B. ELSWIJK, ..., Cited on page **146**.
- 136** J. SPENCE & U. WEIERSTRASS, ..., end 1997. Cited on page **146**.
- 137** Some religions incredibly, still pretend that people believe the opposite. Cited on page .
- 138** Thermostatics is difficult to learn also because it was not discovered in a systematic way, as told by C. TRUESDELL, *The tragicomical history of thermodynamics 1822-1854*, Springer Verlag, 1980.
An excellent advanced textbook on thermostatics and thermodynamics is LINDA REICHL, *A modern course in statistical physics*, Wiley, 2nd edition, 1998. Cited on page **147**.
- 139** The famous paper on Brownian motion which so much contributed to Einstein's fame is *Über die von der molekularkinetischen Theorie der Wärme geforderte Bewegung von in ruhenden Flüssigkeiten suspendierten Teilchen*, Annalen der Physik **17**, pp. 549–560, 1905. In the following years, Einstein wrote a series of subsequent papers elaborating on this topic. Cited on page **149**.
- 140** The first tests of the prediction were performed by JEAN PERRIN, ... Cited on page **150**.
- 141** Pierre GASPARD & al., *Experimental evidence for microscopic chaos*, Nature **394**, p. 865, 27 August 1998. Cited on page **151**.
- 142** Gas expansion was the main method used for the definition of the official temperature scale. Only in 1990 other methods were introduced officially, such as total radiation thermometry (in the range 140 K-373 K), noise thermometry (2 K-4 K) and (900 K-1235 K), acoustical thermometry (303 K), magnetic thermometry (0.5 K-2.6 K), and optical radiation thermometry (> 730 K). But radiation thermometry is still the central method in the domain from about 3 K to about 1000 K. This is explained in detail in R.L. RUSBY, R.P. HUDSON, M. DURIEUX, J.F. SCHOOLEY, P.P.M. STEUR & C.A. SWENSON, *The basis of the ITS-90*, Metrologia **28**, p. 9, 1991. On the water boiling point see also page **825**. Cited on page **151**.
- 143** See e.g. the article by H. PRESTON-THOMAS, *The international temperature scale of 1990 (ITS-90)*, Metrologia **27**, pp. 3–10, 1990, and the errata H. PRESTON-THOMAS, *The international temperature scale of 1990 (ITS-90)*, Metrologia **27**, p. 107, 1990, Cited on page **151**.
- 144** The weight is given by the pressure of the tires times the contact area. Cited on page **151**.
- 145** An overview of low temperature physics is given by ... Cited on page **151**.
- 146** K. SCHMIDT-NIELSEN, *Desert animals: physiological problems of heat and water*, Oxford University Press, 1964. Cited on page **158**.
- 147** The story that entropy is created when information is erased, not when it is acquired, is told in CHARLES H. BENNETT & ROLF LANDAUER, *Fundamental Limits of Computation*, Scientific American **253:1**, pp. 48–56, 1985. The summary: we should pay to throw the newspaper away, not to buy it. Cited on page **158**.
- 148** F. HERRMANN, *Mengenartige Größen im Physikunterricht*, Physikalische Blätter **54**, pp. 830–832, September 1998. See also his lecture notes on general introductory physics on the <http://www-tfp.physik.uni-karlsruhe.de/~didaktik> web site. Cited on page **152**.

- 149** ILYA PRIGOGINE, ... Cited on page [154](#).
- 150** These points are made clearly and forcibly, as is his style, by N.G. VAN KAMPEN, *Entropie*, nederlands tijdschrift voor natuurkunde **62**, pp. 395–396, 3 December 1996. Cited on page [154](#).
- 151** This is a disappointing result of all efforts so far, as Grégoire Nicolis always stresses in his university courses. Seth Lloyd has compiled a list of 31 different propositions to define complexity, containing among others, fractal dimension, grammatical complexity, computational complexity, thermodynamic depth, etc. See e.g. a short summary in *Scientific American* p. 77, June 1995. Cited on page [155](#).
- 152** K. SCHWENK, *Why snakes have forked tongues*, *Science* **263**, pp. 1573–1577, 1994. Cited on page [161](#).
- 153** P.B. UMBANHOWAR & H.L. SWINNEY, *Localized excitations in a vertically vibrated granular container*, *Nature* **382**, pp. 793–796, 29 August 1996. Cited on page [161](#).
- 154** K. KÖTTER, E. GOLES & M. MARKUS, *Shell structures with ‘magic numbers’ of spheres in a swirled disk*, *Physical Review E* **60**, p. 7182, 1999, See also the <http://www.aip.org/physnews/graphics/html/magicball.html> web site. Cited on page [161](#).
- 155** A good introduction is the text by DANIEL WALGRAEF, *Spatiotemporal pattern formation, with examples in physics, chemistry and material science*, Springer 1996. Cited on page [161](#).
- 156** For an overview, see the Ph.D. thesis by JOCELINE LEGA, *Défauts topologiques associés à la brisure de l’invariance de translation dans le temps*, Université de Nice, 1989. Cited on page [162](#).
- 157** For a clear introduction, see T. SCHMIDT & M. MARHL, *A simple mathematical model of a dripping tap*, *European Journal of Physics* **18**, pp. 377–383, 1997. Cited on page [164](#).
- 158** J.J. LISSAUER, *Chaotic motion in the solar system*, *Reviews of Modern Physics* **71**, pp. 835–845, 1999. Cited on page [165](#).
- 159** The present status of the understanding of turbulence is given in ... Cited on page [165](#).
- 160** For more details, see Appendix [B](#) on units on page [811](#). Cited on page [168](#).
- 161**, *The ray days ..*, .. Cited on page [168](#).
- 162** The history of the measurement of the velocity of light can be found in chapter 19 of the text by F.A. JENKINS & H.E. WHITE, *Fundamentals of optics*, McGraw-Hill, New York, 1957. Cited on page [168](#).
- 163** On the way to perform such a measurement, see SYDNEY G. BREWER, *Do-it-yourself astronomy*, Edinborough University Press, 1988. Kepler himself never measured the distances of planets to the sun, but only ratios planetary distances. The parallax of the sun from two points of the earth is at most 8.79 seconds of arc, as has been measured already in the 18th century.
The measurement of moon distance is now performed with laser beams fired onto a reflector deposited there during the Apollo missions. Distance measurements are done by time of flight measurement of 35 ps laser pulses. See the <http://almagest.as.utexas.edu/~rlr/mlrs.html> and http://cddisa.gsfc.nasa.gov/cstg/slr_cstg.html web sites. Cited on page [169](#).
- 164** The art to make pictures of light pulses with a usual photographic camera, without any electronics, is told by M.A. DUGAY & A.T. MATTICK, *Ultrahigh speed photography of picosecond light pulses and echoes*, *Applied Optics* **10**, 1971, pp. 2162–2170. The picture on page [170](#) is also taken from there. Cited on page [170](#).
- 165** You can learn the basics of special relativity with the help of the web, without referring to any book, by using as a starting point the <http://physics.syr.edu/research/relativity/RELATIVITY.html> web page. This page mentions most English language relativity pages available on the web. Some links in other languages are mentioned on the motion mountain web site. Search engines can help as well. Cited on page [171](#).

- 166** The constancy of light speed deduced from gamma ray bursts shows that the speed of light does not depend on the lamp speed to within one part in 10^{20} , as shown by K. BRECHER, ... 2000. See also his older paper K. BRECHER, *Is the speed of light independent of the source?*, Physics Letters **39**, pp. 1051–1054, Errata 1236, 1977. Measuring the light speed from rapidly moving stars is another way. Some of these experiments are not completely watertight however; there is a competing theory of electrodynamics, by Ritz, which maintains that the speed of light is c only when measured with respect to the source. The light from stars however passes through the atmosphere, and its speed thus Cited on page **171**.
might be reduced to c .
The famous experiment with light emitted from rapid pions at CERN does not suffer from this criticism. It is described in T. ALVÄGER, J.M. BAILEY, F.J.M. FARLEY, J. KJELLMAN & I. WALLIN, *Test of the second postulate of relativity in the GeV region*, Physics Letters **12**, pp. 260–262, 1964. See also Ark. Fys. **31**, p. 145, 1965.
Another precise experiment at extreme speeds is described by G.R. KALBFLEISCH, N. BAGGETT, E.C. FOWLER & J. ALSPECTOR, ..., Physical Review Letters **43**, pp. 1361–1364, 1979.
- 167** EDWIN F. TAYLOR & JOHN A. WHEELER, *Spacetime Physics – Introduction to Special Relativity*, second edition, Freeman, 1992. Cited on page **172**.
- 168** The start of the modern theory of relativity is the famous paper by ALBERT EINSTEIN, *Zur Elektrodynamik bewegter Körper*, Annalen der Physik **17**, pp. 891–921, 1905. It still well worth reading, and every physicist should have done so. It is now available in many languages. Cited on page **171**, **172**.
- 169** ALBERT EINSTEIN, *Mein Weltbild*, ... Cited on page **171**.
- 170** J. VAN BLADEL, *Relativity and Engineering*, Springer 1984. Cited on page **171**.
- 171** See e.g. C. WILL, *Theory and Experiment in Gravitational Physics*, Revised edition, Cambridge University Press, 1993. Cited on page **171**, **172**.
- 172** B.E. SCHAEFER, *Severe limits on variations of the speed of light with frequency*, Physical Review Letters **82**, pp. 4964–4966, 21 June 1999. Cited on page **171**.
- 173** R.J. KENNEDY & E.M. THORNDIKE, *Experimental establishment of the relativity of time*, Physical Review **42**, pp. 400–418, 1932. See also H.E. IVES & G.R. STILWELL, *An experimental study of the rate of a moving atomic clock*, Journal of the Optical Society of America **28**, pp. 215–226, 1938, and **31**, pp. 369–374, 1941. For a modern, high precision version, see C. BRAXMEIER & al., Physical Review Letters January 2002. Cited on page **172**.
- 174** ROD S. LAKES, *Experimental limits on the photon mass and cosmic vector potential*, Physical Review Letters **80**, pp. 1826–1829, 1998. The speed of light is independent of frequency within a factor of $6 \cdot 10^{-21}$, as was shown from gamma ray studies by BRADLEY E. SCHAEFER, *Severe limits on variations of the speed of light with frequency*, Physical Review Letters **82**, pp. 4964–4966, 1999.
An overview of previous results is given in YUAN-CHUNG CHANG & YUAN ZHONG ZHANG, *Special relativity and its experimental foundations*, World Scientific, 1998. Cited on page **173**.
- 175** R.W. MCGOWAN & D.M. GILTNER, *New measurement of the relativistic Doppler shift in neon*, Physical Review Letters **70**, pp. 251–254, 1993. Cited on page **174**.
- 176** The beautiful graph is taken from Z.G.J. GUIRAGOSSIAN & al., ..., Physical Review Letters **34**, pp. 335–338, 1975. Cited on page **176**.
- 177** To know more about the best known crackpots, their ideas, e-mail to major-domo@zikzak.net with the one line body subscribe psychoceramics. Cited on page **176**.

- 178** The speed of neutrinos is the same as that of light within 9 decimal digits, since neutrinos and light arrived together, within 12 seconds, after a trip of 170 000 light years from a supernova explosion. This is explained by LEO STODOLSKY, *The speed of light and the speed of neutrinos*, Physics Letters B **201**, p. 353, 1983. An observation of a small mass for the neutrino has been published by the Japanese Super-Kamiokande collaboration, as Cited on page **177**.
- 179** A general refutation of such proposals is discussed by S.R. MAINWARING & G.E. STEDMAN, *Accelerated clock principles*, Physical Review A **47**, pp. 3611–3619, 1993. Already experiments on *muons* at CERN in 1968 showed that *accelerations* of up to 10^{20} m/s² have no effect, as explained by D.H. PERKINS, *Introduction to high energy physics*, Addison-Wesley, 1972, or by J. BAILEY & al., Il Nuovo Cimento **9A**, p. 369, 1972. Cited on page **180**.
- 180** B. ROTHENSTEIN & G. ECKSTEIN, *Lorentz transformations directly from the speed of light*, American Journal of Physics **63**, p. 1150, 1995. See also the comment by E. KAPUSCIK, American Journal of Physics **65**, p. 1210, 1997. Cited on page **177**.
- 181** A.A. MICHELSON & E.W. MORLEY, *On the relative motion of the earth and the luminiferous ether*, American Journal of Science (3rd series) **34**, pp. 333–345, 1887. Michelson published many other papers on the topic after this one. Cited on page **178**.
- 182** H.A. LORENTZ, *De relative beweging van de aarde en dem aether*, Amst. Versl. **1**, p. 74, 1892, and also H.A. LORENTZ, *Electromagnetic phenomena in a system moving with any velocity smaller than that of light*, Amst. Proc. **6**, p. 809, 1904, or Amst. Versl. **12**, p. 986, 1904, Cited on page **180**.
- 183** W. RINDLER, *General relativity before special relativity: an unconventional overview of relativity theory*, American Journal of Physics **62**, pp. 887–893, 1994. Cited on page **180**.
- 184** If the future could influence the past ... Cited on page **182**.
- 185** STEVEN K. BLAU, *Would topology change allow Ms. Bright to travel backward in time?*, American Journal of Physics **66**, pp. 179–185, 1998. Cited on page **182**.
- 186** On the ‘proper’ formulation of relativity, see for example ... Cited on page **183**.
- 187** The simple experiment to take a precise clock on a plane, fly it around the world, and then compare it with an identical one left in place was first performed by J.C. HAFELE & RICHARD E. KEATING, *Around-the-world atomic clocks: predicted relativistic time gains*, Science **177**, pp. 166–167, and *Around-the-world atomic clocks: observed relativistic time gains*, pp. 168–170, 14 July 1972.
There is also the text by YUAN-CHUNG CHANG & YUAN ZHONG ZHANG, *Special relativity and its experimental foundations*, World Scientific, 1998. Cited on page **183**.
- 188** A readable introduction into the change of time with observers and relativity in general is R. SEXL & H.K. SCHMIDT, *Raum-Zeit-Relativität*, 2. Auflage, Vieweg & Sohn, Braunschweig, 1982. Cited on page **183**.
- 189** PAUL J. NAHIN, *Time machines – time travel in physics, metaphysics, and science fiction*, Springer Verlag and AIP Press, second edition, 1999. Cited on page **183**.
- 190** Most famous is the result that moving muons stay younger, as shown for example by D.H. FRISCH & J.B. SMITH, *Measurement of the relativistic time dilation using μ -mesons*, American Journal of Physics **31**, pp. 342–335, 1963. Cited on page **184**.
- 191** W. RINDLER, *Length contraction paradox*, American Journal of Physics **29**, 1961, pp. 365–366, For a variation without gravity, see R. SHAW, *Length contraction paradox*, American Journal of Physics **30**, p. 72, 1962. Cited on page **184**.
- 192** This situation is discussed by G.P. SASTRY, *Is length contraction paradoxical?*, American Journal of Physics **55**, 1987, pp. 943–946, It also contains an extensive literature list of all variants of length contraction paradoxes. By the way, the bar does not light the lamp at high

- Challenge 144 speeds, even though in the frame of the bar there is always contact. Can you see why? Cited on page 184.
- 193** S.P. BOUGHN, *The case of the identically accelerated twins*, American Journal of Physics **57**, pp. 791–793, 1989. Cited on page 184, 185.
- 194** G.R. RYBICKI, *Speed limit on walking*, American Journal of Physics **59**, pp. 368–369, 1991. Cited on page 186.
- 195** The slowness of the speed of light inside stars is explained e.g. by ... Cited on page 186.
- 196** The first examples of such astronomical observations were provided by A.R. WHITNEY & al., Science **173**, pp. 225–230, 1971, and by M.H. COHEN & al., Astrophysical Journal **170**, pp. 207–217, 1971. See also T.J. PEARSON, S.C. UNWIN, M.H. COHEN, R.P. LINFIELD, A.C.S. READHEAD, G.A. SEIELSTAD, R.S. SIMON & R.C. WALKER, Nature **290**, pp. 365–368, 1981. An overview is given in J.A. ZENSUS & T.J. PEARSON, editors, *Superluminal radio sources*, Cambridge University Press, 1987. A more recent example was reported in Science News **152**, p. 357, 6 December 1997.
A pedagogical explanation is given by D.C. GABUZDA, *The use of quasars in teaching introductory special relativity*, American Journal of Physics **55**, pp. 214–215, 1987, and by EDWIN F. TAYLOR & JOHN A. WHEELER, *Spacetime Physics - Introduction to special relativity*, second edition, Freeman, 1992, pages 89–92. This excellent book was mentioned already in the text. Cited on page 187.
- 197** O.M. BILANIUK & E.C. SUDARSHAN, *Particles beyond the light barrier*, Physics Today **22**, pp. 43–51, 1969, O.M.P. BILANUK, V.K. DESHPANDE & E.C.G. SUDARSHAN, ‘Meta’ relativity, American Journal of Physics **30**, pp. 718–723, 1962. See also E. RECAMI, editor, *Tachyons, monopoles, and related topics*, North-Holland, Amsterdam, 1978. Cited on page 188.
- 198** [4] J.P. Costella, B.H.J. McKellar, A.A. Rawlinson, G.J. Stephenson/ *The Thomas rotation*, American Journal of Physics **69**, pp. 837–847, 2001. Cited on page 189.
- 199** See S.S. COSTA, G.E.A. MATSAS, *Temperature and relativity*, <http://arxiv.org/gr-qc/9505045>. Cited on page 189.
- 200** This information is due to a private communication by Frank DiFilippo; part of the story is given in F. DIFILIPPO, V. NATARAJAN, K.R. BOYCE & D.E. PRITCHARD, *Accurate atomic masses for fundamental metrology*, Physical Review Letters **73**, pp. 1481–1484, 1994. These measurements were performed with Penning traps; a review of the possibilities they offer is given by R.C. THOMPSON, *Measurement Science and Technology* **1**, p. 93, 1990. The most important experimenters in the world of single particle levitation were awarded the Nobel prize in 1989. Their Nobel prize lectures can be found in W. PAUL, *Electromagnetic traps for neutral and charged particles*, Reviews of Modern Physics **62**, pp. 531–540, 1990. Cited on page 193.
- 201** J.L. SYNGE, *Relativity: the special theory*, North-Holland, 1956, pp. 208–213. More about antiparticles in special relativity can be found in J.P. COSTELLA, B.H.J. MCKELLAR & A.A. RAWLINSON, *Classical antiparticles*, American Journal of Physics **65**, pp. 835–841, 1997. See also reference 214. Cited on page 194.
- 202** A. PAPAPETROU, *Drehimpuls- und Schwerpunktsatz in der relativistischen Mechanik*, Praktika Acad. Athenes **14**, p. 540, 1939, A. PAPAPETROU, *Drehimpuls und Schwerpunktsatz in der Diracschen Theorie*, Praktika Acad. Athenes **15**, p. 404, 1940, M.H.L. PRYCE, *The mass-centre in the restricted theory of relativity and its connexion with the quantum theory of elementary particle*, Physical Review A **195**, pp. 62–81, 1948. Cited on page 195.
- 203** A readable article showing a photocopy of a letter by Einstein making this point is LEV B. OKUN, *The concept of mass*, Physics Today pp. 31–36, June 1989. The topic is not without

- controversy, as the letters following that article show; they are found in *Putting to rest mass misconceptions*, Physics Today pp. 13–14, as well as pp. 115–117, May 1990. The topic is still source of debates. Cited on page 200.
- 204** A jewel among the textbooks on special relativity is the booklet by ULRICH E. SCHRÖDER, *Spezielle Relativitätstheorie*, Verlag Harri Deutsch, Thun, 1981. Cited on page 199, 200.
- 205** C. MØLLER, *The theory of relativity*, Clarendon Press, Oxford, 1952, 1972. This standard text has also been translated in several other languages. Cited on page 200.
- 206** R.J. LOW, *When moving clocks run fast*, European Journal of Physics **16**, pp. 228–229, 1995. Cited on page 204, 205.
- 207** WOLFGANG RINDLER, *Relativity – special, general, and cosmological*, 2001. A beautiful book by one of the masters of the field. Cited on page 205.
- 208** EDWARD A. DESLOGE & R.J. PHILPOTT, *Uniformly accelerated reference frames in special relativity*, American Journal of Physics **55**, pp. 252–261, 1987. Cited on page 207.
- 209** The impossibility to define rigid coordinate frames for non-uniformly accelerating observers is discussed by CHARLES MISNER, KIP THORNE & JOHN A. WHEELER, *Gravitation*, Freeman, 1973, page 168. Cited on page 206.
- 210** CARL G. ADLER & ROBERT W. BREHME, *Relativistic solutions to a falling body in a uniform gravitation field*, American Journal of Physics **59**, pp. 209–213, 1991. Cited on page 208.
- 211** R.H. GOOD, *Uniformly accelerated reference frame and twin paradox*, American Journal of Physics **50**, pp. 232–238, 1982. Cited on page 207, 208, 210.
- 212** J. DWAYNE HAMILTON, *The uniformly accelerated reference frame*, American Journal of Physics **46**, pp. 83–89, 1978. Cited on page 208.
- 213** The best and cheapest mathematical formula collection remains the one by K. ROTTMANN, *Mathematische Formelsammlung*, BI Hochschultaschenbücher, 1960. Cited on page 208.
- 214** See for example D.J. RAYMOND, *A Radically modern approach to introductory physics*, on the <http://www.physics.nmt.edu/raymond/ph13xbook/index.html> web site. Cited on page 208, 231.
- 215** EDWARD A. DESLOGE, *The gravitational red shift in a uniform field*, American Journal of Physics **58**, pp. 856–858, 1990. Cited on page 210.
- 216** The propagation delays to be discussed in the chapter on general relativity can be seen as confirmations of this effect. Cited on page 210.
- 217** W. RINDLER & L. MISHRA, *The nonreciprocity of relative acceleration in relativity*, Physics Letters A **173**, 1993, pp. 105–108. Cited on page .
- 218** The subtleties of the one-way and two-way speed of light are explained in ... Cited on page 211.
- 219** EDWIN F. TAYLOR & A.P. FRENCH, *Limitation on proper length in special relativity*, American Journal of Physics **51**, pp. 889–893, 1983. Cited on page 212.



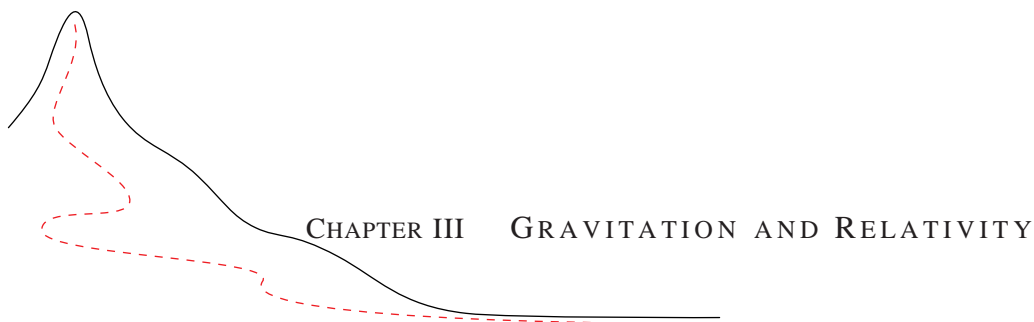

Gravitational influences do transport energy.* In the description of motion, the next goal must therefore be to increase the precision in such a way that this transport happens at most with the speed of light, as Henri Poincaré stated already in 1905. The results will be fascinating; it will be found that empty space can move, that the universe has a finite age, that objects can be in permanent free fall, and that space can be bent – despite being much stiffer than steel.

Describing motion due to gravity using $a = GM/r^2$ not only allows speeds larger than light, e.g. in orbits; it is also unclear how the values of a and r depend on the observer. The expression thus cannot be correct. In order to achieve a consistent description, called *general relativity* by Albert Einstein, we have to throw quite a few preconceptions overboard.

Ref. 1, 2

7. The new ideas on space, time, and gravity

Sapere aude.
Horace**

What is the opposite of motion in daily life? A body at rest, such as a child sleeping. Or a man listening. Or a rock defying the waves. And when is a body at rest? When it is not disturbed by other bodies. In the Galilean description of the world, rest thus is the *absence of velocity*. With special relativity, rest became *inertial motion*, since no inertially moving observer can distinguish its own motion from rest: nothing disturbs him. This is the case for the rock in the waves and for the rapid protons crossing the galaxy as cosmic rays. But the study of gravity leads to an even more general definition.

Rest and free fall

If any body moving inertially is to be considered at rest, then any body in free fall must also be. Nobody knows this better than Joseph Kittinger, the man who in August 1960 stepped out of a balloon capsule at the record height of 31.3 km. At that altitude, the air is so thin that during the first minute of his free fall he felt completely at rest, as if he were floating. He was so surprised that he had to turn upwards in order to convince himself that he was

Challenge 161

Ref. 3

* About the details of this far from simple statement, see page 277 and page 255.

** ‘Venture to be wise.’ Horatius, Quintus Flaccus, Ep. 1, 2, 40.

really getting away from his balloon! In fact he was falling at up to 988 km/h with respect to the earth's surface. He started feeling something only from the moment that he encountered the first layers of air, thus when his free fall started to be disturbed. Later, after four and a half minutes of fall, his special parachute opened, and nine minutes later he landed safely in New Mexico.

He and all other observers in free fall, such as the cosmonauts circling the earth, make the same observation: it is impossible to distinguish anything happening in free fall from what would happen at rest. This impossibility is called the *principle of equivalence*; it is one of the starting points of general relativity. It leads to the most precise – and final – definition of rest: *rest is free fall*. The set of all free falling observers that meet at a point in space-time generalize the set of the inertial observers that can meet at a point in special relativity.

Among others, this means that we must describe motion in such a way that not only inertial but also freely falling observers can talk to each other. In fact, a full description of motion must be able to describe gravitation and the motion it produces, and must be able to describe motion for any observer imaginable. This is the aim that general relativity realizes.

To pursue it, we put the original result in simple words, true *motion is the opposite of free fall*. This conclusion directly produces a number of questions: Most trees or mountains are not in free fall, thus they are not at rest. What motion are they undergoing? And if free fall is rest, what is weight? And what then is gravity anyway? Let us start with the last question.

Challenge 178

What is gravity?

Ref. 14 As William Unruh likes to explain, the constancy of the speed of light for all observers implies the following conclusion: *gravity is the uneven running of clocks at different places.**

Challenge 212

Of course, this seemingly absurd definition needs to be checked.

Note that the definition does not talk about a single situation seen by *different* observers, as we often did in special relativity. The definition states that neighbouring, identical clocks, fixed against each other, run differently in the presence of a gravitational field when watched by the *same* observer; moreover, this difference is defined to be what we usually call gravity. There are two ways to check this connection: by experiment, and by reasoning. Let us start with the latter method, as it is cheaper, faster, and more fun.

An observer feels no difference between gravity and constant acceleration. Thus we can use a result we encountered already in special relativity. If light is emitted at the back end of an accelerating train of length Δh , it arrives at the front end after a time $t = \Delta h/c$. However, during this time the accelerating train has picked up some additional velocity, namely $\Delta v = gt = g\Delta h/c$. As a result, due to the Doppler effect, the frequency of the light arriving at the front has changed. Inserting, one gets **

See page 185

Challenge 229

Challenge 195

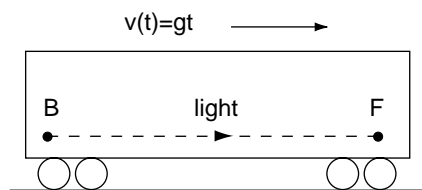

Figure 110 Colours inside an accelerating train or bus

* Gravity is also the uneven length of meter bars at different places, as we will see below. Both effects are needed to describe it completely; but for daily life on earth, the clock effect is sufficient, since it is much larger than the length effect, which can be usually be neglected. Can you see why?

$$\frac{\Delta f}{f} = \frac{g\Delta h}{c^2} = \frac{\Delta\tau}{\tau} \quad (169)$$

Note that the sign of the frequency change depends on whether the light motion and the train acceleration are in the same or in opposite directions. For actual trains or buses, the frequency change is quite small. But before we discuss the consequences of the result, let us check it with a different experiment.

To measure time and space, we use light. What happens to light when gravity is involved? The simplest experiment is to let light fall or rise in a gravitational field. In order to deduce what must happen, we add a few details. Imagine a conveyor belt carrying masses around two wheels, a low and a high one. The descending, grey masses are slightly larger. Whenever such a larger mass is near the bottom, some mechanism – not drawn – converts the mass surplus to light via $E = mc^2$ and sends the light up towards the top. * At the top, one of the lighter, white masses passing by absorbs the light and, due to its added weight, turns the conveyor belt until it reaches the bottom. Then the process repeats.

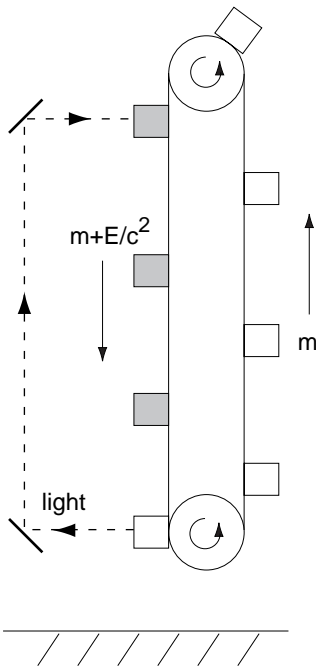

Figure 111 The necessity of blue and redshift of light: why trees are greener at the bottom

As the left masses are always heavier, the belt would turn for ever, and this system could continuously generate energy. However, since energy conservation is at the basis of our definition of time, as we saw in the beginning of our walk, the whole process must be impossible. We have to conclude that the light changes its energy while climbing the height h . The only possibility is that the light arrives at the top with frequency *different* from the one at which it is emitted from the bottom. **

In short, it turns out that rising light is gravitationally redshifted. Similarly, the light descending from the top of a tree down to an observer is *blue shifted*; this gives a darker, older colour to the top in comparison to the bottom of the tree. General relativity thus says that trees have different shades of green along their height. *** How big is the effect? The result deduced from the drawing is again the one of formula (169). That is expected, as the two experiments describe equivalent situations, as you might want to check yourself. The formula gives a relative change of frequency f of only $1.1 \cdot 10^{-16} / m$ on the surface of the earth. For trees, this so-called *gravitational red shift* or *gravitational Doppler effect* is far too small to be observable, at least using normal light.

In 1911, Einstein proposed to check the change of frequency with height by measuring the redshift of light emitted by the sun, using the famous

** The expression $v = gt$ is valid only for small speeds; nevertheless, the conclusion of the section is independent of this approximation.

* As in special relativity, here and in the rest of our mountain ascent, the term ‘mass’ always refers to rest mass.
** The relation between energy and frequency of light is described and explained in the part on quantum theory, on page 492.

*** How does this argument change if one includes the illumination by the sun?

Challenge 263

Ref. 8

See Figure 111

See page 136

Challenge 297

Challenge 314

Ref. 21

Challenge 246

Challenge 280

Fraunhofer lines as colour markers. The first experiments, by Schwarzschild and others, were unclear or even negative, due to a number of other effects that change colours at high temperatures. Only in 1920 and 1921, Grebe and Bachem, and independently Perot, showed that careful experiments indeed confirm the gravitational red shift. In later years, technology made the measurements much easier, until it was even possible to measure the effect on earth. In 1960, in a classic experiment using the Mössbauer effect, Pound and Rebka

Ref. 9 confirmed the gravitational red shift in their university tower using γ radiation.

But our two thought experiments tell us much more. Using the same arguments as in the case of special relativity, the colour change also implies that clocks run *differently* at the top and at the bottom, as they do in the front and in the back of a train. Therefore, in gravity, *time is height dependent*, as the definition says. In fact, *height makes old*. Can you confirm this conclusion?

Challenge 348

In 1972, by flying four precise clocks in an aeroplane, and keeping an identical one on the ground, Hafele and Keating found that clocks indeed run differently at different altitudes according to expression (169). Subsequently, in 1976, a team around Vessot shot a clock based on a maser, a precise microwave generator and oscillator, upwards on a missile, and again confirmed the expression by comparing it with an identical maser on the ground. And in 1977, Briatore and Leschiutta showed that a clock in Torino indeed ticks slower than one on the top of the Monte Rosa. They confirmed the prediction that on earth, for every 100 m of height gained, one ages more rapidly by about 1 ns per day. In the mean time this effect has been confirmed for all gravitational systems for which experiments were performed, such as several other planets, the sun, and many other stars.

Ref. 10

Ref. 11

Ref. 12

Challenge 365

In summary, gravity is indeed the uneven running of clocks at different heights. Note that both an observer at the lower position and one at a higher position *agree* on the result; both find that the upper clock goes faster. In other words, when gravity is present, space-time is *not* described by the Minkowski space-time of special relativity, but by some more general space-time. To put it mathematically, whenever gravity is present, one has

$$ds^2 \neq c^2 dt^2 - dx^2 - dy^2 - dz^2 \quad . \quad (170)$$

We will give the correct expression shortly. But is this view of gravity really reasonable? No. It turns out that it is not yet strange enough.

If the speed of light is the same for all observers, we get an additional result. If time changes with height, also length must do so! More precisely, if clocks run differently at different heights, also the length of meter bars changes with height. Can you confirm this, using the fact that the speed of light is the same everywhere?

Challenge 382

As a result, the circumference of a circle around the earth *cannot* be given by $2\pi r$. A discrepancy is also found by an ant measuring radius and circumference of a large circle traced on the surface of a basketball. Humans are thus in a similar position as ants on a basketball, with the only difference that the situation is translated from two to three dimensions. The conclusion is thus unavoidable: wherever gravity plays a role, like on the surface of the earth, space is curved.

What tides tell about gravity

This is a section of the freely downloadable e-textbook

Motion Mountain

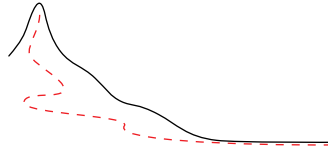

Hiking beyond space and time along the concepts of modern physics

available at
www.motionmountain.org

Copyright © 1997, 1998, 1999, 2000, 2001, 2002 by Christoph Schiller

To the kind reader

In exchange for getting this section for free, I ask you for a short email on some of the following:

- Which page was boring?
- Did you find any mistakes?
- What else were you expecting?
- What was hard to understand?

Of course, any other suggestion is welcome. This section is part of a physics text written over many years. The text lives and grows through the feedback from its readers, who help to improve and to complete it. For a particularly useful contribution (send it in english, italian, dutch, german, spanish, portuguese, or french) you will be mentioned in the foreword of the text, or receive a small reward, or both.

Enjoy!

Christoph Schiller
cs@motionmountain.org

Challenge 331

During his fall, Kittinger could specify an inertial frame for himself. Indeed, he felt completely at rest. Does this mean that it is impossible to distinguish acceleration from gravitation? No; distinction *is* possible. One only has to compare *two* (or more) falling observers.

Challenge 399

Kittinger could not have found a frame which is also inertial for a colleague falling on the opposite side of the earth. In fact, such a common frame does not exist. In general, it is impossible to find a *single* inertial reference frame describing different observers freely falling near a mass.

In fact, even two *nearby* observers in a gravitational field are affected. Two nearby observers observe that during fall, their relative distance changes. As a consequence, a large body in free fall is slightly *squeezed*. The essence of gravity is that free fall is *different* from point to point.

See page 93

That rings a bell. The squeezing of the body is the same effect that leads to the tides. Indeed, the bulging oceans can be seen as the squeezed earth in its fall towards the moon. We thus are lead back to the results of universal gravity and state: a typical effect of gravity is the observation of tidal effects.

Ref. 6

In other words, gravity is simple only *locally*. Only locally it looks like acceleration. Only locally, a falling observer like Kittinger feels at rest. In fact, only a point-like observer does so! As soon as one takes spatial extension into account, one finds tidal effects. *Gravity is the presence of tidal effects*. The absence of tidal effects implies the absence of gravity. Kittinger could have *felt* gravitation, even with his eyes closed, if he would have paid attention, during his free fall, to himself. Had he measured the distance change between his two hands, he would have found a tiny decrease which could have told him that he was falling, even with his eyes closed.

This tiny decrease would have forced Kittinger to a strange conclusion. Two freely falling hands should move along two parallel lines, always keeping the same distance. If the distance changes, it means that the space around him was one in which lines starting out in parallel do not remain so. Kittinger would have concluded that the space around him was similar to the surface of a sphere, where two lines starting out north, parallel to each other, also change distance, until they meet at the north pole. In other words, Kittinger would have concluded that he was in a *curved* space.

Studying the value of the distance decrease between his hands, Kittinger would even have concluded that the curvature changes with time. So the space is not like the one of a sphere, which has constant curvature, but more involved.

In fact the effect is extremely small, and cannot be felt by human senses. Detection requires special high sensitivity apparatuses. However, the conclusion is the same. Space-time is *not* described by Minkowski-space when gravity is present. Tidal effects imply space-time curvature.

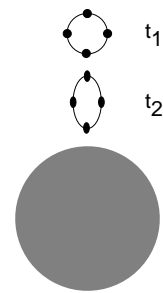

Figure 112 Tidal effects: what bodies feel when falling

Bent space

Wenn ein Käfer über die Oberfläche einer Kugel krabbelt, merkt er wahrscheinlich nicht, daß der Weg, den er zurücklegt, gekrümmt ist. Ich dagegen hatte das Glück, es zu merken.*

Albert Einstein's answer to his son Eduard's question about the reason for his fame

On the 7th of November 1919, Albert Einstein became world famous. On that day, the Times newspaper in London announced the results of a double expedition to South America, which for the first time proved that the theory of universal gravity, essentially given by $a = GM/r^2$, was wrong, and that instead space had been shown to be *curved*. A worldwide mania started. Einstein was presented as the greatest of all geniuses. 'Space warped' was the most common headline. Einstein's papers on general relativity were reprinted in full in popular magazines, so that people found the field equations of general relativity, in tensor form and with Greek indices, in the middle of Time magazine. This did not happen to any other physicist before or afterwards.

The expedition had performed an experiment proposed by Einstein himself. Apart from searching for the change of time with height, he had thought about a number of experiments to detect the curvature of space. In the one that eventually made him famous, Einstein proposed to take a picture of the stars near the sun, as is possible during a solar eclipse, and compare it with a picture of the same stars at night, when the sun is far away. Einstein predicted a change in position of 1.75' for star images at the border of the sun, a result *twice* as large as the effect predicted by universal gravity. The prediction, corresponding to about 1/40 mm on the photographs, was confirmed in 1919, and thus universal gravity was ruled out.

Ref. 5

See page 95

Does this experiment *imply* that space is warped or *curved*, as physicists prefer to say? The answer is simple: no, it doesn't, but space-time is curved alright. In fact, other explanations could be given for the result of the eclipse experiment, such as a potential differing from the one of universal gravity.

However, the eclipse is not alone: we know about the change of time with height. Experiments show that any two observers at different height measure the same value for the speed of light c near themselves, as experiments confirm. But these experiments also show that if an observer measures the speed of light at the position of the *other* observer, he gets a value *differing* from c , since his clock runs differently. There is only one possible solution to this dilemma: meter bars, like clocks, also *change* with height, and in such a way to yield the same speed of light everywhere.

Since meter bars change with height, *space is curved near masses*. In the twentieth century, many experiments checked whether meter bars indeed behave differently where gravity is present. Curvature has been detected around several planets, around all the hundreds of stars where it could be measured, and around dozens of galaxies. Many indirect effects of curvature around masses, to be described in detail below, have also been measured. All results confirm the curvature of space and space-time, and confirm the predicted values. In

Challenge 416

* When a bug walks over the surface of a sphere it probably does not notice that the path it walks is curved. I had the luck to notice it.

other words, near masses meter bars do indeed change their size from place to place, and even from orientation to orientation. Figure 113 gives an impression of the situation.

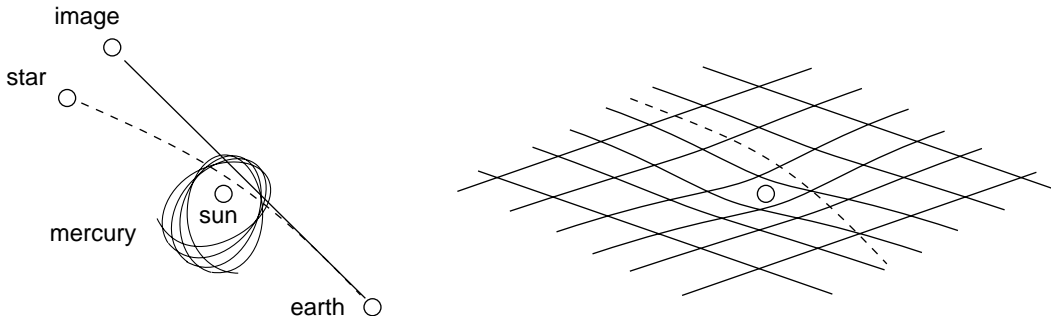

Figure 113 The path of a light beam and of a satellite near a spherical mass

Ref. 4 But attention: the right hand figure, even though found in all textbooks, is misleading. It can be easily mistaken to show a *potential* around a body. Indeed, it is impossible to draw a graph showing curvature and potential separately. (Why?) We will see that for small curvatures, it is in fact possible to describe the meter bar change with a potential only! Thus the figure does not really cheat, at least in the case of weak gravity. But for large and changing values of gravity, potentials cannot be defined, and thus there is indeed no way to avoid curved space in the general case. We will discuss later on how curvature can be measured.

Challenge 433

If gravity means curved space, one follows that any accelerated observer, like a man standing on the earth, must also observe that space is curved. But obviously, in everyday life we do not note any such effect. How then would you devise a precision experiment to check the statement?

Challenge 450

In fact, not only space, but also space-time is curved, even though Figure 113 only shows the curvature of space alone. We will shortly find out how to describe both the shape of space as well as the shape of space-time.

In the case of Figure 113, the best description of events is the use of a time t defined as the time measured by a clock located at infinity; that avoids problems with the uneven running of clock with distance from the central mass. For a radial coordinate r the most practical choice to avoid problems with the curvature of space is to use the circumference of a circle around the body divided by 2π .

The shape of space-time is best described by the behaviour of the space-time distance ds , or by the wristwatch time $d\tau = ds/c$, between two neighbouring points with coordinates (t, r) and $(d + dt, r + dr)$. We know from above that gravity means that in spherical coordinates one has

See page 180

See page 236

$$d\tau^2 = \frac{ds^2}{c^2} \neq dt^2 - dr^2/c^2 - r^2 d\phi^2/c^2 \quad . \quad (171)$$

This inequality means that space-time is *curved*. Indeed, the experiments on clock behaviour with height show that the space-time interval around a spherical mass is given by

$$d\tau^2 = \frac{ds^2}{c^2} = \left(1 - \frac{2GM}{rc^2}\right) dt^2 - \frac{dr^2}{c^2 - \frac{2GM}{r}} - \frac{r^2}{c^2} d\phi^2 \quad (172)$$

This expression is called the *Schwarzschild metric* after one of its discoverers.* The metric (172) describes the curvature of space-time around a spherical non-rotating mass, such as well approximated by the earth or the sun. (Why can the rotation be neglected?) Gravity's strength is obviously measured by a dimensionless number h defined as

Challenge 467

$$h = \frac{2GM}{c^2 R} \quad (173)$$

This ratio expresses the gravitational strain with which lengths and the vacuum are deformed from the flat situation of special relativity, and thus also expresses the amount that clocks go late when gravity is present. On the surface of the earth the ratio h has the small value of $1.4 \cdot 10^{-9}$, and on the surface of the sun the larger value of $4.2 \cdot 10^{-6}$. Modern clocks can easily detect these changes. The consequences and uses will be discussed shortly.

One also notes that if a mass gets small, in particular when its radius gets *equal* to its so-called *Schwarzschild radius*

$$R_s = \frac{2GM}{c^2} \quad (174)$$

the above metric behaves strangely: time disappears. At the Schwarzschild radius, the wrist-watch time stops. What happens precisely will be shown below. The situation is not common; the Schwarzschild radius for the earth is 8.8 mm and for the sun 3.0 km; you might want to check that the object size for all systems in everyday life is always smaller. Bodies who reach this limit are called *black holes*, and we will study them in detail shortly. In fact, as stated above, general relativity states and is based on the fact that *no* system in nature is smaller than its Schwarzschild size, or that h is *never* above unity.

See page 316

Challenge 484

In summary, the results mentioned so far make it clear that *mass generates curvature*. Special relativity then tells us that as a consequence, space should also be curved by energy-momentum. For example, light or neutrinos should also curve space-time. Unfortunately, even the highest energy beams correspond to extremely small masses, and thus to unmeasurably small curvatures. Nevertheless it is still possible to show experimentally that energy also curves space, since in almost all atoms, a large part of the mass is due to the electrostatic energy among the positively charged protons. For example, in 1968 Kreuzer showed this with a clever experiment using a floating mass.

Ref. 16

It is straightforward to picture that the uneven running of clock is the temporal equivalent of space-time curvature. The complete statement is therefore to say that in case of gravity, *space-time* is curved.

Challenge 501

* Karl Schwarzschild (1873–1916), important German astronomer; he was one of the first persons to understand general relativity. He published his solution in december 1915, only few months after Einstein had published his field equations. He died prematurely, at age 42, much to Einstein's chagrin. We will deduce the metric later on, directly from the field equations of general relativity.

Ref. 15 The other discoverer, unknown to Einstein, was the Dutch physicist J. Droste.

In summary, since gravity is similar to acceleration, since acceleration is position dependent time, and since light speed is constant, one deduces that *energy-momentum tells space-time to curve*. This statement is the first half of general relativity.

The *amount* of curvature induced by gravity, as well as the way to measure it, will be uncovered shortly. Obviously, different observers measure different curvatures. The set of transformations from one viewpoint to the other in general relativity is called *diffeomorphism symmetry*. We will study it in more detail below.

Since matter moves, one can say even more. Not only is space-time curved near masses, it also bends back when a mass has passed by. In other words, general relativity states that space, as well as space-time, is *elastic*. However, it is rather stiff, and quite a lot stiffer than steel. * In fact, to curve a piece of space by 1%, one needs an energy density enormously larger than that required to curve a usual train rail by 1%. This and other consequences of space-time curvature and of its elasticity are a lot of fun, and will occupy us for a little while.

Challenge 518

The speed of light and the constant of gravitation

Si morior, moror.**

All the experiments about gravity just cited, as well as all others, can be summed up in two general observations:

▷ *The speed v of a physical system is bound by the limit*

$$v \leq c \quad (175)$$

Ref. 7 *for all observers, where c is the speed of light.*

This description following from this first principle, *special* relativity, is extended to *general* relativity by adding a second principle:

▷ *Any small, resting physical system of mass M accelerates any other system at large distance R with a magnitude*

$$a \approx \frac{GM}{R^2} \quad (176)$$

where G is the gravitational constant.

Equivalently, one of the following, more splashy forms can be used:

▷ *The radius R and the surface A of a resting, spherical system of mass M and constant density are related by*

$$R - \sqrt{\frac{A}{4\pi}} = \frac{GM}{3c^2} \quad (177)$$

* A good book in popular style on the topic is DAVID BLAIR & GEOFF MCNAMARA, *Ripples on a cosmic sea*, Allen & Unwin, 1997.

** 'If I rest, I die.' Motto of the bird of paradise.

The curvature of space can be also expressed differently:

▷ The acceleration a produced by a system of mass M is limited by

$$a \leq \frac{c^4}{4GM} . \quad (178)$$

This expression also implies a limit for the curvature of space-time. This limit can also be expressed in other ways.

▷ The size L of a system of mass M is limited by

$$\frac{L}{M} \geq \frac{4G}{c^2} . \quad (179)$$

▷ The surface A of a system of mass M is limited by

$$A \geq \frac{16\pi G^2 M^2}{c^4} . \quad (180)$$

We will discuss and motivate these new limits all over this chapter, including the section on black holes. We will show that they are all equivalent to each other, and that no exceptions in nature are known. They all reduce to the usual definition of gravity in the non-relativistic case. All tell *what* gravity is, namely curvature, and *how* exactly it behaves. Together, the first and any of the second principles imply all of general relativity.* They are valid for *all* observers. It makes no difference whether an observer feels gravity, is in free fall, is accelerated, or is in inertial motion. No exceptions are known.

For example, are you able to show that the formula describing gravitational redshift complies with the general limit (179) on length to mass ratios?

Challenge 535

The mountain ascent so far has taught us that a precise description of motion requires the listing of all possible viewpoints, their characteristics and their differences, as well as the transformations from one viewpoint to the other. As this time, *all* viewpoints are allowed, without exception; anybody must be able to talk to anybody else. People who exchange left and right, people who exchange up and down, people who say that the sun turns around the earth, as well as any other observers must be able to talk to each other. This gives a much larger set of viewpoint transformations than in the case of special relativity, and makes general relativity both difficult and fascinating. And since all viewpoints are possible, the resulting description of motion is *complete*.**

Why does a stone thrown into the air fall back? – Geodesics

In special relativity, we saw that inertial or free floating motion is that motion which connects two events that requires the *longest* proper time. The motion fulfilling this requirement in the absence of gravity is *straight* motion. So far, we are used to think of straightness as the shape of light rays. Indeed, we all are used to check the straightness of an edge by looking along it. And whenever we draw the axes of a physical coordinate system, we imagine drawing paths of light rays.

See page 49

* This didactic approach is somewhat unconventional.

** Were it not for a small deviation called quantum theory.

In the absence of gravity, object paths and light paths coincide. However, when gravity is present, objects do not move along light paths, as every thrown stone shows. In the case of gravity, both paths are bent, but by *different* amounts. Light does not define spatial straightness any more. But the other statement remains: even when gravity is present, bodies follow paths of *longest possible proper time*. Such paths are called (*timelike*) *geodesics* for objects and (*lightlike*) *geodesics* for light.

In other ways, we can say the following: *stones fall because they follow geodesics*. This statement can be checked in several ways. One is to use the equivalence of gravity and acceleration. Another is to show that it follows from the limit on size to mass ratios. Still another is to check it explicitly, using the curvature of space.

Challenge 552 - If fall is seen as a consequence of the earth's surface approaching, one can deduce directly that fall implies a proper time as long as possible.

Challenge 569 - If gravitation is seen as the result of one of the splashy principles, the issue is also interesting. To put it an extremely simple way, take a vanishingly light object orbiting around a mass M at distance R . It undergoes an acceleration a . Now the acceleration a of a component in a system of size $2R$ is limited, as we found out in special relativity, by $2aR \leq c^2$. This limit is compatible with the splashy size limit of systems *only* if the gravitational acceleration a is given by universal gravity's $a = GM/R^2$ at large distances. The size limit is thus *equivalent* to universal gravity.

Challenge 586 The acceleration limit given above can be seen as the combination of the size limit and the acceleration of universal gravity, as you may want to check. In other words, the acceleration limit implies universal gravity as well. And we know that fall following universal gravity in turn implies longest proper time.

- If fall is seen as consequence of the curvature of space-time, the explanation is a bit more involved.

– CS – story to be filled in – CS –

In short, the straightest path in space-time for a stone thrown in the air and the straightest path for the thrower himself cross again after a while: stones do fall back. Only if the velocity of the stone is too large, the stone does not fall back: it then leaves the attraction of the earth and makes its way through the sky.

Challenge 603 If fall is a consequence of curvature, then the path of *all* stones thrown on the surface of the earth must have the *same* curvature in space-time. Indeed, take a stone thrown horizontally, a stone thrown vertically, a stone thrown rapidly, or a stone thrown slowly: it takes only two lines to show that *in space-time* their paths all are approximated to high precision by circle segments, and that all have the *same* curvature radius r given by

$$r = \frac{c^2}{g} \approx 9.2 \cdot 10^{15} \text{ m} . \quad (181)$$

The large value of the radius, corresponding to an extremely low curvature, explains why we do not notice it in everyday life. The parabola shape typical of the path of a stone in everyday life is just the projection of the more fundamental path in space-time. The important point is that the value of the curvature does *not* depend on the details of the throw. In fact, this simple result could have brought people onto the path of general relativity already a full century

before Einstein; what was missing was the recognition of the importance of the speed of light. In any case, this simple calculation confirms that fall and curvature are connected. As expected and mentioned already above, the curvature diminishes at larger heights, until it vanishes when one is infinitely far from the earth. As a note, the excess radius description of gravitation given above is just another way to describe curvature with numbers; more about this other method will be found out shortly.

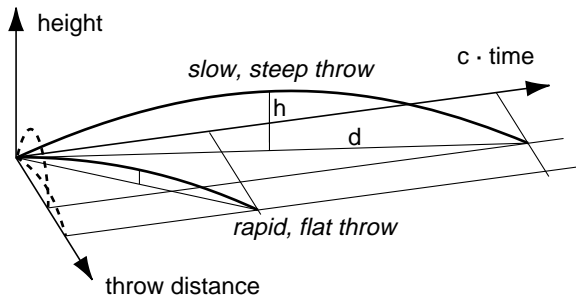

Figure 114 All paths of flying stones have the same curvature in space-time

Note that in space-time, geodesics are the curves with *maximal* length. This is in contrast with the case of pure space, such as the surface of a sphere, where geodesics are the curves of *minimal* length.

In summary, the motion of any particle falling freely ‘in a gravitational field’ is described by the same variational principle as the motion of a free particle in special relativity: the path maximizes the

proper time $\int d\tau$. We rephrase this by saying that any particle in free fall from point *A* to point *B* minimizes the action *S* given by

$$S = -mc^2 \int_A^B d\tau \quad . \quad (182)$$

That is all one needs to know about the free fall of objects. As a consequence, any *deviation from free fall keeps young*.

As we will see below, this description of free fall has been tested extremely precisely, and no differences between this expression and experiment has ever been observed. We will also see that for free fall, the predictions of general relativity and of universal gravity differ substantially both for particles near the speed of light as well as for central bodies near the size to mass limit. In particular, all experiments show that whenever the two predictions differ, general relativity is right and universal gravity, as well as all other alternatives developed so far, are wrong.

See page 326
Ref. 17

Above we called free fall the official definition of *rest*; we can thus say that with general relativity everything about rest (of large bodies) is known, as well as everything about the departure from it.

Of course, the next question is whether energy falls in the same way as mass. *Bound* energy does so, as is proven by comparing the fall of objects made of different materials. They have different percentages of bound energy. (Why?) For example, on the moon, where there is no air, cosmonauts dropped steel balls and feathers and found that they fell in the same way, alongside each other. The independence on material composition has been checked over and over again, and no difference has ever been found.

Challenge 620

Ref. 18

What about radiation? Radiation is energy without rest mass and moves like extremely fast and extremely light objects. Therefore deviations from universal gravity become most

Ref. 19
See page 95

apparent for light. Does light fall? Already long before relativity, in 1801, the Prussian astronomer Johann Soldner understood that universal gravity implies that light is *deflected* when passing near a mass. He also calculated the deflection angle, which depends on the mass of the body and the distance of passage. But nobody cared to check the result experimentally. Obviously, light has energy, and energy also has weight; the deflection of light by itself is thus *not* a proof of the curvature of space.

See page 259

General relativity also predicts a deflection angle for light passing masses, but of *twice* the classical value, because the curvature of space around large masses adds to the effect already included by universal gravity. The deflection of light thus only proves the curvature of space if the *value* agrees with the one predicted by general relativity. And indeed, the observations coincide with the prediction. More calculation and experimental details will be given shortly.

In short, all experiments show that not only mass, but also energy falls along geodesics, whatever its type, bound or free, and whatever the interaction, be it electromagnetic or nuclear. Moreover, the motion of radiation confirms that space-time is curved. In summary, we find that *space-time tells matter, energy and radiation how to fall*. This statement is the second half of general relativity.

To complete the description of macroscopic motion, we only need to add numbers to these statements, so that they become testable. As usual, we can proceed in two ways: we can deduce the equations of motion directly, or we can first deduce the Lagrangian and then deduce the equations of motion from it. But before we do that, we have some fun.

General relativity in everyday life

Wenn Sie die Antwort nicht gar zu ernst nehmen und sie nur als eine Art Spaß ansehen, so kann ich Ihnen das so erklären: Früher hat man geglaubt, wenn alle Dinge aus der Welt verschwinden, so bleiben noch Raum und Zeit übrig. Nach der Relativitätstheorie verschwinden aber auch Zeit und Raum mit den Dingen. *

Albert Einstein in 1921 in New York

Curiosities about gravitation

General relativity is a beautiful topic with numerous interesting aspects. One can learn a lot from its more curious sides.

- Challenge 637 ■ Take a plastic bottle and make some holes into it. Fill it with water, closing the holes with your fingers. If you let the bottle fall, during the fall no water will leave the bottle. How does this confirm the equivalence of rest and free fall?
- Challenge 654 ■ The radius of curvature of space-time at the earth's surface is $1.7 \cdot 10^{11}$ m. Are you able to confirm this value?
- See page 185 ■ We saw in special relativity that if two twins are identically accelerated in the same direction, the first one ages more than the second one. Is this the same in a gravitational field? What happens, when the field varies with height, as happens on the earth?
- Challenge 671

* If you do not take the answer too seriously and take it only for amusement, I can explain it to you in the following way: in the past it was thought that if all things disappear from the world, space and time would remain. But following relativity theory, space and time disappear together with the things.

- How do cosmonauts weigh themselves, when they want to check whether they eat enough? Challenge 688
- A piece of wood floats on water. Does it stick out higher in an elevator accelerating up? Challenge 705
- Is a cosmonaut really floating freely? No. It turns out that space stations and satellites are accelerated by several effects. The important ones are the pressure of the light from the sun, the friction of the thin air, and the effects of solar wind; micrometeorites can usually be neglected. They all lead to accelerations of the order of 10^{-6} m/s^2 to 10^{-8} m/s^2 , depending on the height of the orbit. When will an apple floating in space hit the wall of a space station? Challenge 722
By the way, what is the magnitude of the tidal accelerations in this situation?
- There is no negative mass in nature, as discussed in the beginning of our walk. This means that gravitation cannot be shielded, in contrast to electromagnetic interactions. Even antimatter has positive mass. Since gravitation cannot be shielded, there is no way to make a perfectly isolated system. But such systems form the basis of thermodynamics! We will study the fascinating troubles this implies later on; for example, an *upper limit* for the entropy of systems will appear. See page 63
- Can curved space be used to travel faster than light? Imagine a space-time in which two points could be connected either by a path leading through a flat portion of space-time, or by a second path leading through a partially curved portion. Could that curved portion be used to travel between the points faster than through the flat one? Yes; however, such a curved space would need to have a *negative* energy density. Such a situation is in contrast with the definition of energy and with the nonexistence of negative mass. The requirement that this does not happen is also called the *weak energy condition*. Can you say whether it is included in the limit on length to mass ratios? Ref. 22
Challenge 739
- Like in special relativity, the limit $L/M \geq 4G/c^2$ is a challenge to devise experiments to overcome it. Can you explain what happens when a fast observer moves past a mass, so that it is length contracted until the limit is reached? Challenge 756
- There is an important mathematical aspect which singles out the dimension 3 from all other possibilities. A closed curve can be knotted *only* in \mathbf{R}^3 , whereas it can be unknotted in any other, i.e. higher dimension. (This fact is also the reason that three is the smallest dimension that allows chaotic particle motion.) However, general relativity does not tell *why* space-time has three plus one dimensions. It is simply based on the fact. This difficult issue will be settled only in the third part of the mountain ascent.
- Henri Poincaré, who died in 1912, shortly before the general theory of relativity was finished, thought that curved space was not a necessity, but only a possibility. He thought that one could simply continue using Euclidean space and simply add that light follows curved paths. Can you show why his idea is wrong? Challenge 773
- Can two atoms circle each other, in their respective gravitational field? What would be the size of this ‘molecule’? Challenge 790
- Can two light pulses circle each other, in their respective gravitational field? Challenge 807
- The various motions of the earth mentioned in the section on Galilean physics, such as rotation around its axis, rotation around the sun, etc., lead to various types of time in physics and astronomy. The time defined by the best atomic clocks is called ‘terrestrial dynamical time’. By inserting leap seconds every now and then to compensate for the bad definition of the second (an earth rotation does not take 86 400, but 86 400.002 seconds) and, in minor ways, for the slowing of earths rotation, one gets the *universal time coordinate*; then one has See page 79
See page 818

the time derived from this by taking into account all those *leap seconds*. One then has the – different – time which would be shown by a nonrotating clock in the centre of the earth. Finally, one has ‘barycentric dynamical time’, which is the time that would be shown by a clock in the centre of mass of the solar system. Only using this latter time satellites can be reliably steered through the solar system. In summary, relativity says goodbye to Greenwich mean time, as does British law, in one of a few cases where the law follows science.

Ref. 23

▪ Space agencies thus *have* to use general relativity if they want to get artificial satellites to Mars, Venus, or comets. Without its use, orbits would not be calculated correctly, and satellites would miss the aimed spots and usually even the whole planet. In fact, space agencies take the safe side; they use a generalization of general relativity, namely the so-called *parametrized post-Newtonian formalism*, which includes a continuous check whether general relativity is correct. Within measurement errors, no deviation was ever found so far.*

Ref. 24

▪ General relativity is also used by space agencies around the world to know the exact positions of satellites and to tune radios to the frequency of radio emitters on them. The so-called *global positioning system*, or GPS, is now becoming a standard tool in navigation.** GPS consists of 24 satellites with clocks flying around the world. Why does the system need general relativity to operate? Since both a satellite as well as a person on the surface of the earth travel in circles, we have $dr = 0$ and we can rewrite the Schwarzschild metric (172) as

$$\left(\frac{dt}{dt}\right)^2 = 1 - \frac{2GM}{rc^2} - r^2\left(\frac{d\phi}{dt}\right)^2 = 1 - \frac{2GM}{rc^2} - v^2 \quad (184)$$

Challenge 824 For the relation between satellite and earth time we then get

$$\left(\frac{dt_{\text{sat}}}{dt_{\text{earth}}}\right)^2 = \frac{1 - \frac{2GM}{r_{\text{sat}}c^2} - \frac{v_{\text{sat}}^2}{c^2}}{1 - \frac{2GM}{r_{\text{earth}}c^2} - \frac{v_{\text{earth}}^2}{c^2}} \quad (185)$$

Challenge 841

Can you deduce how many microseconds a satellite clock runs fast every day, given that the GPS satellites turn around the earth every twelve hours? Since only three microseconds would give a position error of one kilometre after a single day, the clocks in the satellites are adjusted to run slow by the calculated amount. The results confirm general relativity within experimental errors.

Ref. 25

Ref. 26

▪ The gravitational constant G does not seem to change with time. Present experiments limit its rate of change to less than 1 part in 10^{12} per year. Can you imagine how this can be checked?

Challenge 858

* To give an idea of what this means, the *unparametrized* post-Newtonian formalism, based on general relativity, writes the equation of motion of a body of mass m near a large mass M as

$$a = \frac{GM}{r^2} + f_2 \frac{GM}{r^2} \frac{v^2}{c^2} + f_4 \frac{GM}{r^2} \frac{v^4}{c^4} + f_5 \frac{Gm}{r^2} \frac{v^5}{c^5} + \dots \quad (183)$$

where the numerical factors f_n are of order one. The first uneven terms are missing because of reversibility, were it not for gravity wave emission, which accounts for the small term f_5 ; note that it contains the small mass instead of the large one. Nowadays, all factors f_n up to f_7 have been calculated. However, in the solar system, only the term up to f_2 has ever been detected, a situation which might change with future high precision satellite experiments. Higher order effects, up to f_5 , have been measured in the binary pulsars, as discussed below.

See page 258

For a *parametrized* post-Newtonian formalism, all factors f_n , including the uneven ones, are fitted through the data coming in; so far all these measured factors agree with general relativity’s prediction.

** For more information, see the <http://www.gpsworld.com> web site.

▪ Could the idea that we live in 3 space dimensions be due to a limitation of our senses? Challenge 875
How?

▪ Can you estimated the effect of the tides on the colour of the light emitted by an atom? Challenge 892

▪ What is the strongest possible gravitational field? The one of black small holes, as already mentioned. The strongest *observed* gravitational field is somewhat smaller though. In 1998, Zhang and Lamb used the x-ray data from a double star system to determine that space-time near the 10 km sized neutron star is curved up to 30% of the maximum possible value. What is the maximal gravitational acceleration, assuming a mass equal to the sun? Ref. 27
Challenge 909

▪ What is the angular size δ of a mass M with radius r at distance d ? Light deflection leads to the pretty expression Challenge 926

$$\delta = \arcsin\left(\frac{r\sqrt{1-R_S/d}}{d\sqrt{1-R_S/r}}\right) \quad \text{where} \quad R_S = \frac{2GM}{c^2} \quad (186)$$

We will come back to the issue shortly.

See page 322

▪ Much information about general relativity is available on the net. As a good starting point for US-American material, see the <http://math.ucr.edu/home/baez/relativity.html> web site.

▪ Is it correct to claim that matter cannot be continuous because inside a closed shell of matter gravity can still be present? Challenge 943

What is weight?

We saw that a *single* (and point-like) observer cannot distinguish the effects of gravity from those of acceleration. This property of nature allows to make a strange statement: things *fall* because the surface of the earth accelerates towards them. Therefore, the *weight* of an object results from the surface of the earth accelerating upwards and pushing against the object. That is the principle of equivalence applied to everyday life.

Obviously, an accelerating surface of the earth produces a weight for each body which is proportional to its inertial mass, or, as this is usually expressed, the inertial mass of a body is exactly identical to the gravitational one. This is indeed observed, and to the highest precision achievable. Roland von Eötvös* performed many such high-precision experiments throughout his life, without finding any discrepancy. In these experiments, he used the fact that the inertial mass is important for centrifugal effects and the gravitational mass is important for free fall. Can you imagine how exactly he tested the equality? Ref. 13
Challenge 960

However, this is not a surprise. Remembering the definition of mass ratio as negative inverse acceleration ratio, independently of the origin of the acceleration, we are reminded that mass measurements cannot be used to distinguish inertial and gravitational mass at all. We saw that both masses are equal by definition already in Galilean physics, and that the whole discussion is a red herring. See page 61
See page 96

In any case, when we step into an elevator in order to move down a few stories, and push the button, the following happens: the elevator is pushed upwards by the accelerating surface

* Roland von Eötvös (1848, Budapest–1919, Budapest), hungarian physicist. He performed many precision gravity experiments; among others, he discovered the effect named after him. The university of Budapest is named after him.

of the earth somewhat less than the building; the building overtakes the elevator, which therefore remains behind. Moreover, due to the weaker push, at the beginning everybody inside the elevator feels a bit lighter. When the contact with the building is restored, the elevator is accelerated to catch up with the accelerating surface of the earth. Therefore we all feel like in a strongly accelerating car, pushed into direction opposite to the acceleration: for a short while, we feel heavier. And of course, during free fall, we feel no weight; this is obvious, since no floor is pushing.

Why do apples fall?

Vires acquirit eundo.
Vergilius *

Answering this question is now straightforward. Sitting in an accelerating car, an object thrown forward will soon be caught by the car again. For the same reason, a stone thrown upwards is soon caught up by the surface of the earth, which is continuously accelerating upwards. Similarly, when an apple detaches from a tree, it stops being accelerated by the branch. The apple can now enjoy the calmness of real rest. Unfortunately, the accelerating surface of the earth approaches mercilessly and, depending on the time the apple stayed at rest, the earth hits it with a corresponding velocity, leading to more or less severe shape deformation.

We are not disturbed any more by the statement that gravity is the uneven running of clocks with height. In fact, this statement is *equivalent* to saying that the surface of the earth is accelerating upwards, as the discussion above showed.

Can this reasoning can be continued without limit? One can go on for quite a while; it is fun to show how the earth can be of constant radius even though its surface is accelerating upwards everywhere.

Challenge 977

As said above, the equivalence between acceleration and gravity ends as soon as two falling objects are studied. The study of several bodies inevitably leads to the conclusion that *gravity is curved space-time*. Many aspects of this description can be understood without or with little mathematics. The next section shows some of the differences between universal gravity and general relativity, showing that the ideas presented so far do agree with experiment. After that, a few concepts around the measurement of curvature are introduced, and they are applied to the motion of objects and space-time. If the concepts get too involved for a first reading, just skip these parts and continue with the sections on cosmology and on black holes, which again use little mathematics.

8. Motion in general relativity – bent light and wobbling vacuum

I have the impression that Einstein understands relativity theory very well.
Chaim Weizmann, chemist, later first president of Israel

Before we enter the deepest guts of general relativity, we study how the motion of objects and light *differs* from that predicted in universal gravity, and how these differences can be measured.

* 'Going it acquires strength.' Publius Vergilius Maro (Andes, 70 BCE–Brundisium, 19 BCE), *Aeneis* 4, 175.

Weak fields

As mentioned above, one calls *strong* gravity those situations for which the prediction by universal gravity strongly deviate from experiment. This happens when

$$\frac{2GM}{Rc^2} \approx 1 \quad (187)$$

and applies near black holes, as we will see below, or to extremely high energies, as we will discover in the third part of our mountain ascent. For most of nature, gravity is a *weak* effect, despite the violence of avalanches or of falling asteroids, and the number just mentioned much smaller than one. In these cases, gravitation can still be approximated by a field, despite what was said above. These weak field situations are interesting because they are simple to understand, as they only require for their explanation the different running of clocks with height, allowing to mention space-time curvature only in passing and still to think of gravity as a source of acceleration. However, many new and interesting effects appear.

The Thirring effects

In 1918, the German physicist Joseph Thirring published two simple and beautiful predictions of motions, one with his collaborator Hans Lense, which do not appear in universal gravity, but do appear in general relativity.

Ref. 34

In the first example, called the *Thirring effect*, centrifugal accelerations as well as Coriolis accelerations on all masses in the interior of a rotating mass shell are predicted, in contrast to the description of universal gravity. Are you able to deduce this effect from the figure?

Challenge 994

The *Thirring-Lense effect* is somewhat more complex. It predicts that the oscillating Foucault pendulum, or a satellite circling the earth in a polar orbit, does not stay precisely in a fixed plane compared to the rest of the universe, but that the earth drags the plane along a tiny bit. This *frame-dragging*, as it is also called, arises from the fact that the earth in vacuum behaves like a ball in honey; when it rotates, it drags some honey with it. Similarly, the earth drags some vacuum with it, and thus moves the plane of the pendulum. Of course, the effect also moves the plane of an orbiting satellite.

The Thirring-Lense effect has been measured for the first time in 1998 by the Italian group led by Ignazio Ciufolini. They followed the motion of two special artificial satellites consisting only of a body of steel and some cat eyes. The group measured the satellite's motion around the earth with extremely high precision using reflected laser pulses. This method allowed this low budget experiment to beat by many years the efforts of much larger but much more sluggish groups.* The results confirm general relativity within about 25%.

Ref. 35

Frame dragging effects have also been measured in binary star systems, which is possible if one of the stars is a pulsar; such stars send out regular radio pulses, e.g. every millisecond. By measuring the exact time when they arrive on earth, one can deduce the way these stars move, and confirm even such subtle effects as frame dragging.

Ref. 36

* Such as the so-called Gravity Probe B satellite experiment, which will drastically increase the measurement precision around the year 2005.

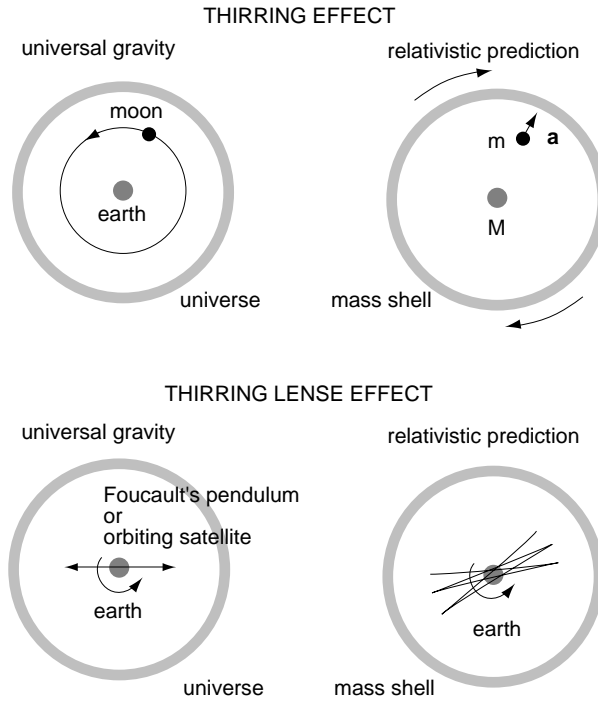

Figure 115 The Thirring and the Thirring-Lense effects

Gravitomagnetism

Frame-dragging and the Thirring-Lense effect can be seen as special cases of gravitomagnetism. This approach to gravity, already studied by Heaviside, has become popular again in recent years, especially for its didactic aspect. As mentioned above, talking about a gravitational *field* is always an approximation. But for weak gravity, it is a good one. Many relativistic effects can be described with it, without using space curvature nor the metric tensor. For a relativistic description of such weak gravity situations, the field can be split into an ‘electric’ and a ‘magnetic’ component, as is done for the electromagnetic field.*

Like in the case of electromagnetism, the split depends on the observer; in addition, electromagnetism provides a good feeling on how the two fields behave. The frame dragging effects just mentioned can be visualised by this method quite easily. The acceleration of a charged particle in electrodynamics is described by the Lorentz’ equation

See page 345

$$m\ddot{\mathbf{x}} = q\mathbf{E} - q\dot{\mathbf{x}} \times \mathbf{B} \quad . \quad (188)$$

In other words, change of speed is due to electric fields \mathbf{E} , and in addition, magnetic fields \mathbf{B} are those fields which give a velocity-dependent direction change of velocity, without changing the speed itself. The changes depend on the value of the charge q . In the case of gravity this expression, as we will show below, becomes

$$m\ddot{\mathbf{x}} = m\mathbf{G} - m\dot{\mathbf{x}} \times \mathbf{H} \quad . \quad (189)$$

* The approximation requires slow velocities, weak fields, as well as localized and stationary mass-energy distributions.

The role of charge is taken by mass. In this expression we already know the field \mathbf{G} , given by

$$\mathbf{G} = \nabla\phi = \nabla\frac{GM}{r} = -\frac{GM\mathbf{x}}{r^3} . \tag{190}$$

As usual, the quantity ϕ is the (scalar) potential. This is the field of universal gravity, as produced by every mass, and in this context is called the *gravitoelectric field*.

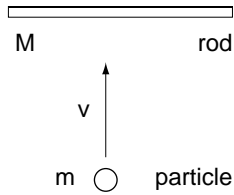

In fact it is not hard to show that if *gravitoelectric* fields exist, *gravitomagnetic* fields must exist as well, as the latter appear whenever one changes from an observer at rest to a moving one. (The same argument is used in electrodynamics.) A particle falling perpendicularly towards an infinitely long rod already makes the point, as shown in Figure 116. An observer at rest with respect to the rod can describe the whole situation with gravitoelectric

Ref. 37

Figure 116 The reality of gravitomagnetism

forces alone. A second observer, moving along the rod with constant speed, observes that the momentum of the particle *along the rod* also increases. Equivalently, moving masses produce a gravitomagnetic (3-) acceleration on test masses m given by

Challenge 1011

$$m\mathbf{a} = -m\mathbf{v} \times \mathbf{H} \tag{191}$$

where, as in electrodynamics, a static *gravitomagnetic field* obeys

$$\mathbf{H} = \nabla \times \mathbf{h} = 4\pi N\rho\mathbf{v} \tag{192}$$

where ρ is mass density and N is a proportionality constant. The quantity \mathbf{h} is obviously called the *gravitomagnetic (vector) potential*. We see that universal gravity is the approximation of general relativity appearing when all gravitomagnetic effects are neglected.

When the situation in Figure 116 is evaluated, one gets

Challenge 1028

$$N = \frac{G}{c^2} = 7.4 \cdot 10^{-28} \text{ m/kg} , \tag{193}$$

an extremely small value. In addition, a second point renders the observation extremely difficult. In contrast to electromagnetism, in the case of gravity there is no way to observe *pure* gravitomagnetic fields (why?); they are always mixed with the usual, gravitoelectric ones. And as in the electrodynamic case, the gravitoelectric fields are stronger by a factor of c^2 . For these reasons, gravitomagnetic effects have been measured for the first time only in the 1990s. In short, *if a mass moves, it also produces a gravitomagnetic field*. In this description, *all frame dragging effects are gravitomagnetic effects*.

Challenge 1045

Obviously, a gravitomagnetic field also appears when a large mass *rotates*. For an angular momentum J it is given by

$$\mathbf{H} = \nabla \times \mathbf{h} = \nabla \times \left(-2\frac{\mathbf{J} \times \mathbf{x}}{r^3} \right) \tag{194}$$

exactly as in the electrodynamic case. In particular, like in electromagnetism, a spinning test particle with angular momentum \mathbf{S} feels a *torque* if it is near a large spinning mass with angular momentum \mathbf{J} . And obviously, this torque \mathbf{T} is given by

$$\mathbf{T} = \frac{d\mathbf{S}}{dt} = \frac{1}{2}\mathbf{S} \times \mathbf{H} \quad (195)$$

Since for a torque one has $\mathbf{T} = \dot{\mathbf{\Omega}} \times \mathbf{S}$, a large rotating mass with angular momentum \mathbf{J} has an effect on an orbiting particle. Seen from infinity one gets, for an orbit with semimajor axis a and eccentricity e ,

Challenge 1062

$$\dot{\mathbf{\Omega}} = -\frac{\mathbf{H}}{2} = -\frac{\mathbf{J}}{|\mathbf{x}|^3} + \frac{3(\mathbf{J}\mathbf{x})\mathbf{x}}{|\mathbf{x}|^5} = \frac{2\mathbf{J}}{a^3(1-e^2)^{3/2}} \quad (196)$$

which is the prediction by Thirring and Lense.* The effect is extremely small, giving a change of only 8'' per orbit for a satellite near the surface of the earth. Despite this smallness, and a number of larger effects disturbing it, Ciufolini’s team managed to confirm the result.

The use of the split into gravitoelectric and gravitomagnetic effects corresponds to an approximation in which only clock effects of gravity are taken into account, as we will find out below. Despite this limitation, the approach is quite useful. For example, it helps to answer questions such as: How can gravity keep the earth around the sun, if gravity needs 8 minutes to get from the sun to us? To find the answer, thinking about an electromagnetic analogy can help.

Challenge 1096

In addition, the split of the gravitational field into gravitoelectric and gravitomagnetic components also allows a simple description of gravity waves.

Gravitational waves

Table 25 The expected spectrum of gravitational waves

Frequency	Wavelength	Name	Expected appearance
$< 10^{-4}$ Hz	> 3 Tm	extremely low frequencies	slow binary star systems, supermassive black holes
10^{-4} Hz- 10^{-1} Hz	3 Tm-3 Gm	very low frequencies	fast binary star systems, massive black holes, white dwarf vibrations
10^{-1} Hz- 10^2 Hz	3 Gm-3 Mm	low frequencies	binary pulsars, medium and light black holes
10^2 Hz- 10^5 Hz	3 Mm-3 km	medium frequencies	supernovae, pulsar vibrations
10^5 Hz- 10^8 Hz	3 km-3 m	high frequencies	unknown; possibly human made sources
$> 10^8$ Hz	< 3 m		unknown, possibly cosmological sources

Challenge 1079

* A homogeneous spinning sphere has an angular momentum given by $J = \frac{2}{5}M\omega R^2$.

One of the most fantastic predictions of physics is the existence of gravitational waves. Gravity waves prove that empty space-time itself has the ability to move and vibrate. The basic idea is simple. Since space-time is elastic, it should be able to oscillate in the form of propagating waves, like any other elastic medium.

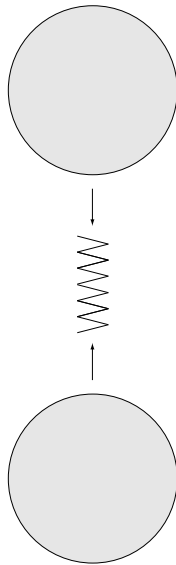

Figure 117 A Gedankenexperiment showing the necessity of gravity waves

Jørgen Kalckar and Ole Ulfbeck have given a simple argument for the logical necessity of gravitational waves by studying two equal masses falling towards each other. They simply imagined a spring between them, which would make them bounce towards each other again and again. The central spring stores the kinetic energy from the falling masses. That energy can be measured by determining, with a metre bar, the length by which the spring is compressed. When the spring springs back and hurls the masses back into space, the gravitational attraction will gradually slow down the masses, until they again fall towards each other, thus starting the same cycle again.

Ref. 38

However, the energy stored in the spring gets smaller with each cycle. At every bounce, the spring is compressed a little less. When a sphere detaches from the spring, it obviously is decelerated by the other sphere due to the gravitational attraction. Now comes the point. The value of this deceleration depends on the distance to the other mass; but since there is a maximal propagation velocity, the effective deceleration is given by the distance the other mass *had* when its gravity reached the end of the spring. In short, while departing, the real deceleration is *larger* than the one calculated without taking the time delay into account.

Similarly, when the mass falls back down towards the other, it is accelerated by the other mass using the distance it had when its gravity effect reached the other. Therefore, while going down, the acceleration is *smaller* than the one without time delay.

As a total effect, the masses arrive with a *smaller* energy than they departed with. The difference of these two energies is lost by each mass; it is taken away by space-time. The energy is radiated away as gravitational radiation. As we will see, this effect has already been measured, with the difference that the two masses, instead of being tied by a spring, were orbiting each other.

A simple mathematical description of gravity waves appears with the split into gravitomagnetic and gravitoelectric effects. It does not take much to extend gravitostatics and gravitoelectrostatics to *gravitodynamics*. Just as electrodynamics can be deduced from Coulomb's attraction when one switches to other inertial observers, gravitodynamics can be deduced from universal gravity. One gets the four equations

Ref. 39

Challenge 1113

$$\begin{aligned} \nabla \mathbf{G} &= -4\pi G \rho \quad , \quad \nabla \times \mathbf{G} = -\frac{\partial \mathbf{H}}{\partial t} \\ \nabla \mathbf{H} &= 0 \quad , \quad \nabla \times \mathbf{H} = -4\pi G \rho + \frac{N}{G} \frac{\partial \mathbf{G}}{\partial t} \end{aligned} \quad (197)$$

which are *exactly the same* as those for electrodynamics. One can easily deduce a *wave equation* for the gravitoelectric and the gravitomagnetic fields \mathbf{G} and \mathbf{H} . In other words, *gravity can behave like a wave; gravity can radiate*. All this follows from the expression

of universal gravity when applied to moving observers, using the fact that observers cannot move faster than c . The story with the spring and the mathematical story use the same assumptions and come to the same conclusion.

Challenge 9 A few manipulations show that the speed of these waves is given by

$$c = \sqrt{\frac{G}{N}} \tag{198}$$

See page 365 which corresponds to the famous electromagnetic expression

$$c = \frac{1}{\sqrt{\epsilon_0 \mu_0}} \tag{199}$$

The same letter has been used for the two speeds, as they are identical. Indeed, both influences travel with the speed common to all energy moving with vanishing rest mass.

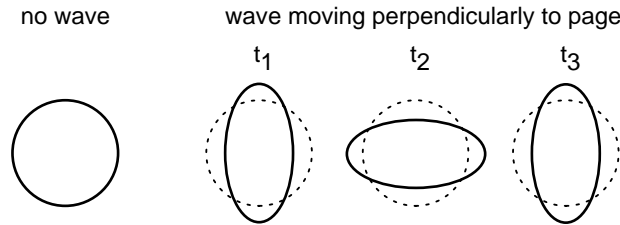

Figure 118 Effects on a circular or spherical body of a plane gravitational wave moving vertically to the page

How does one have to imagine these waves? The waves correspond to moving deformations of space-time. It turns out that gravity waves are *transverse*. One finds also that waves can be polarized in two ways. The effect of a gravitational wave in one polarization is shown in Figure 118. The effect of the other polarization is the same, rotated by 45 degrees. * Can

Challenge 26

* A (small amplitude) plane gravity wave travelling in z -direction is described by a metric

$$g = \begin{pmatrix} 1 & 0 & 0 & 0 \\ 0 & -1+h_{xx} & h_{xy} & 0 \\ 0 & h_{xy} & -1+h_{xx} & 0 \\ 0 & 0 & 0 & -1 \end{pmatrix} \tag{200}$$

where its two components, whose amplitude ratio determine the polarization, are given by

$$h_{ab} = A_{ab} \sin(kz - \omega t + \varphi_{ab}) \tag{201}$$

as in all plane harmonic waves. The dispersion relation resulting from the wave equation is

$$\frac{\omega}{k} = c \tag{202}$$

and shows that the waves move with the speed of light.

In another gauge, a plane wave can be written as

$$g = \begin{pmatrix} c^2(1+2\varphi) & A_1 & A_2 & A_3 \\ A_1 & -1+2\varphi & h_{xy} & 0 \\ A_2 & h_{xy} & -1+h_{xx} & 0 \\ A_3 & 0 & 0 & -1 \end{pmatrix} \tag{203}$$

where φ and \mathbf{A} are the potentials such that $\mathbf{G} = \nabla\varphi - \frac{\partial\mathbf{A}}{c\partial t}$ and $\mathbf{H} = \nabla \times \mathbf{A}$.

you imagine what happens to the circular body if a circularly polarized wave hits it?

Challenge 43

How does one produce such waves? The conservation of energy does not allow changing mass monopoles. Also a spherical mass which changes in radius periodically would not emit gravitational waves. The conservation of momentum does not allow changing mass dipoles. In summary, only *changing quadrupoles* can emit waves. For example, two masses in orbit around each other will emit gravitational waves. Also any rotating object which is not cylindrically symmetric around the rotation axis will do so: rotating an arm emits gravitational waves.

Challenge 60

Einstein found that the amplitude of waves at a distance r from a source is given to good approximation by the second derivative of the retarded quadrupole moment:

$$h_{ab} = \frac{2G}{c^4} \frac{1}{r} d_{tt} Q_{ab}^{\text{ret}} = \frac{2G}{c^4} \frac{1}{r} d_{tt} Q_{ab}(t - r/c) \quad (204)$$

This shows that the amplitude of gravity waves *decreases only with* $1/r$, in contrast to naive expectations. However, also this feature is the same as for electromagnetic waves. In addition, the small value of the prefactor, $1.6 \cdot 10^{-44} \text{ Wm/s}$, shows that one needs truly gigantic systems to produce quadrupole moment changes yielding any detectable length variations $\delta l/l = h$. To be convinced, just insert a few numbers, keeping in mind that the best present detectors are able to measure length changes down to $\delta l/l = 10^{-19}$. The production of sizeable gravitational waves by humans is (probably) impossible.

Challenge 77

Gravity waves, like all other waves, transport energy.* Specializing the general formula for the emitted power P to the case of two masses m_1 and m_2 in circular orbits around each other at distance l one gets

Ref. 2

$$P = -\frac{dE}{dt} = \frac{G}{45c^5} \ddot{Q}_{ab}^{\text{ret}} \ddot{Q}_{ab}^{\text{ret}} = \frac{32}{5} \frac{G}{c^5} \left(\frac{m_1 m_2}{m_1 + m_2} \right)^2 l^4 \omega^6 \quad (205)$$

which, using Kepler's relation $4\pi^2 r^3 / T^2 = G(m_1 + m_2)$, becomes

$$P = \frac{32}{5} \frac{G^4}{c^5} \frac{(m_1 m_2)^2 (m_1 + m_2)}{l^5} \quad (206)$$

For elliptical orbits, the rate is higher.** Inserting the values in the case of the earth and the sun, one gets a power of about 200 W, and a value of 400 W for the Jupiter-sun system. These values are so small that their effect cannot be detected at all.

The *frequency* of the waves is twice the orbital frequency, as you might want to check.

Challenge 94

As a result, the only observation of effects gravitational waves to date is in binary pulsars. Pulsars are extremely small stars; even with a mass equal to that of the sun, their diameter is only about 10 km; thus they can orbit each other at very small distances and at high speeds. Indeed, in the most famous binary pulsar system, PSR 1913+16, the two stars orbit each other in an amazing 7.8 h, even though their semimajor axis is about 700 Mm, just less than twice the earth-moon distance. Since their orbital speed is up to 400 km/s, the system is noticeably relativistic.

* Gravitomagnetism and gravitoelectricity, as in electrodynamics, allow to define a gravitational Poynting vector. It is as easy to define and use as in the electrodynamic case.

Ref. 37 ** See e.g. the explanation by Goenner.

Ref. 2

Pulsars have a useful property: due to their rotation, they emit extremely regular radio pulses (hence their name), often in millisecond periods. Therefore it is easy to follow their orbit by measuring the change of pulse arrival time. In a famous experiment, a team of astrophysicists around Joseph Taylor* measured the speed decrease of the binary pulsar system just mentioned. Eliminating all other effects, and collecting data for 20 years, they found a slowing down of the orbital frequency shown in Figure 119. The slowdown is due to gravity wave emission. The results exactly fits the prediction by general relativity, *without any adjustable parameter*.

Ref. 41

Challenge 111

See page 248

Ref. 41

Ref. 2

(You might want to check that the effect must be quadratic in time.) This is the only case so far that general relativity has been tested up to the $(v/c)^5$ precision. To get an idea of the precision, this measurement detected a reduction of the orbit diameter of 3.1 mm per orbit, or 3.5 m per year! The measurements were possible only because the two stars in this system are pulsars with small size, large velocities, and purely gravitational interactions. To give an idea, the pulsar rotation period around its axis, about 59 ms, is known with eleven digits of precision, the orbital time of 7.8 h is known to ten digits, and the eccentricity of the orbit with 6 digits.

The *direct* detection of gravitational waves is one of the holy grails of experimental general relativity. The race is on since the 1990s. The basic idea is simple and taken from Figure 118: one takes four bodies, the line connecting one pair being perpendicular to the line connecting the other pair. One then measures the distance changes of each pair. If a gravitational wave comes by, one pair will increase in distance and the other will decrease, at the *same* time.

Since gravitational waves cannot be produced in sufficient strength by humans, for detection one first of all needs a lot of time to wait for a strong enough wave to come by. Secondly, one needs a system able to detect length changes of the order of 10^{-22} or better – in other words, a lot of money. Any detection for sure will make the news in television.**

It turns out that even for a body around a black hole, only about 6% of the rest mass can be radiated away; in particular, most of the energy is radiated during the final fall into the black hole, so that only quite violent processes, such as black hole collisions, are good candidates for detectable gravity wave sources.

Actually, gravity waves are even more interesting if, instead of the linear approximation described here, the full field equations are used. More about the topic shortly.

See page 276

* In 1993 he shared the Nobel prize in physics for his life's work.

Ref. 42

Challenge 128

** The topic of gravity waves is full of interesting sidelines. For example, can gravity waves be used to power a rocket? Yes, say Bonnor and Piper. You might ponder the possibility yourself.

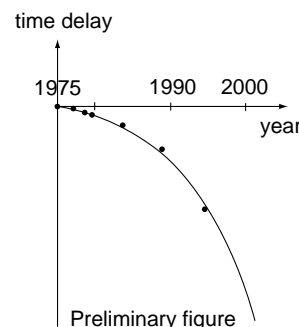

Figure 119 Comparison between measured time delay in the periastron of the binary pulsar PSR 1913+16 and the prediction due to energy loss by gravitational radiation

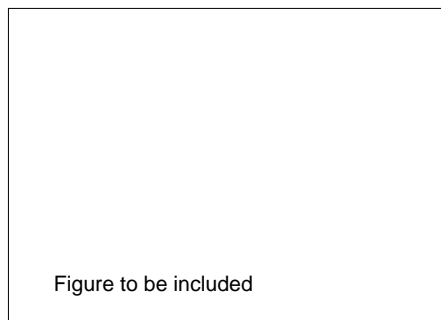

Figure 120 Detection of gravitational waves

By the way, if all change is due to motion of particles, as the Greeks maintained, how do gravity waves fit into the picture?

Challenge 145

Light and radio wave bending

As we know from above, gravity also influences the motion of light. A far away observer measures different values for the light speed near a mass. It turns out that a far away observer measures a *lower* speed, so that for him, gravity has the same effects as a dense medium. It takes only a little bit of imagination that this effect will thus *increase* the bending of light near masses already found in 1801 by Soldner for universal gravity.

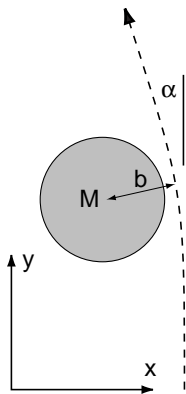

Figure 121
Calculating the bending of light by a mass

To calculate the effect, a simple way is the following. As usual, we use the coordinate system of flat space-time at infinity. The idea is to do all calculations to first order, as the value of the bending is very small. The angle of deflection α , to first order, is simply

Ref. 43

$$\alpha = \int_{-\infty}^{\infty} \frac{\partial c}{\partial x} dy \tag{207}$$

as you might want to confirm. The next step is to use the Schwarzschild metric

Challenge 162

$$d\tau^2 = \left(1 - \frac{2GM}{rc^2}\right) dt^2 - \frac{dr^2}{\left(c^2 - \frac{2GM}{r}\right)} - \frac{r^2}{c^2} d\phi^2 \tag{208}$$

and transform it into (x, y) coordinates to first order. That gives

Challenge 179

$$d\tau^2 = \left(1 - \frac{2GM}{rc^2}\right) dt^2 - \left(1 + \frac{2GM}{rc^2}\right) \frac{1}{c^2} (dx^2 + dy^2) \tag{209}$$

which again to first order leads to

$$\frac{\partial c}{\partial x} = \left(1 - \frac{2GM}{rc^2}\right) \tag{210}$$

It confirms what we know already, namely that far away observers see light *slowed down* when passing near a mass. Thus one can also call the right hand side a height dependent index of refraction. In other words, constant local light speed leads to a global slowdown. This effect will be discussed again shortly.

Inserting the last result in (207) and using a smart substitution, one gets

Challenge 196

$$\alpha = \frac{4GM}{c^2} \frac{1}{b} \tag{211}$$

where b is the so-called *impact parameter* of the approaching light beam. This value is *twice* the result we found for universal gravity. For the sun, one gets the famous value of $1.75''$, which was confirmed by the measurements of 1919. They made Einstein famous, as they showed that universal gravity is wrong. In fact, Einstein was lucky. The earlier expeditions organized to measure the value had failed. In 1912, it was impossible to take data because of rain, and in 1914 in Crimea, scientists were arrested (by mistake) as spies, due to the

See page 95

beginning of the world war. In 1911, Einstein had published an *incorrect* calculation, giving only the Soldner value; only in 1915, when he completed general relativity, he found the correct result. Therefore Einstein became famous only because the two expeditions before his correct calculations failed.

Ref. 44

See page 95

For high precision experiments around the sun, it is better to measure the bending of radio waves, as they encounter fewer problems when they propagate through the corona. In the mean time, over a dozen independent experiments, using radio sources in the sky which lie on the path of the sun, confirmed general relativity's prediction within a few percent.

Ref. 24, 1, 2

See page 265

Challenge 213

Of course, the bending of light also confirms that in a triangle, the sum of the angles does not add up to π , as was predicted above for curved space. (What is the sign of the curvature?) One thus follows that if light would not be bent near a mass, it would go faster than $c!$ *

So far, bending of radiation has also been observed near Jupiter, near certain stars, near several galaxies, and near galaxy clusters. For the earth, the angle is at most 3 nrad, too small to be measured yet, even though this may change in the near future. There is a chance to detect this value if, as Andrew Gould proposes, the data of the satellite Hipparcos, which is taking precision pictures of the night sky, is analysed properly in the future.

See page 302

Time delay

The above calculation shows that for a distant observer, light is slowed down near a mass. Constant *local* light speed leads to a *global* light speed slowdown. If light were not slowed down near a mass, it would go faster than c for an observer near the mass! In 1964, I.I. Shapiro had the idea to measure this effect. He proposed two methods. The first was to send radar pulses to Venus, and measure the time for the reflection to get back to earth. If the signals pass near the sun, they will be delayed. The second was to use an artificial satellite communicating with earth.

Ref. 45

Ref. 46

Ref. 47

The first measurement was published in 1968, and directly confirmed the prediction by general relativity within experimental errors. All further tests up to the present have confirmed the prediction within experimental uncertainties, which nowadays are of the order of one part in a 1000. The delay has even been measured in binary pulsars, as there are a few such systems for which the line of sight lies almost precisely in the orbital plane.

Orbits

Astronomy allows the most precise measurements of motion, so that Einstein first of all applied his results to the motion of planets. He later said that the moment he found out that his calculation for the precession of Mercury matched observations was one of the happiest of his life.

The calculation is not difficult. In universal gravity, orbits are calculated by setting $a_{\text{grav}} = a_{\text{centri}}$, in other words, by setting $GM/r^2 = \omega^2 r$ and fixing energy and angular momentum. The mass of the particle does not appear explicitly.

Challenge 230

* A nice exercise is to show that the bending of a slow particle gives the Soldner value, whereas with increasing speed, the value of the bending approaches twice that value. In all these considerations, the rotation of the mass has been neglected. As the effect of frame dragging shows, it also changes the deviation angle; however, in all cases studied so far, the influence is below the detection threshold.

In general relativity, the mass of the particle is made to disappear by rescaling energy and angular momentum as $e = E/mc^2$ and $j = J/m$. In addition, the space curvature needs to be included. It is straightforward to use the Schwarzschild metric mentioned above to deduce that the initial condition for the energy E , together with its conservation, leads to a relation between proper time τ and time t at infinity:

Ref. 1, 2
See page 240

$$\frac{dt}{d\tau} = \frac{e}{1 - 2GM/rc^2} \quad (212)$$

whereas the initial condition on the angular momentum J , which is also conserved, means that

$$\frac{d\varphi}{d\tau} = \frac{j}{r^2} \quad (213)$$

These relations are valid for any particle, whatever its mass m . Inserting all this into the Schwarzschild metric, one gets that the motion of a particle follows

$$\left(\frac{dr}{cd\tau}\right)^2 + V^2(j, r) = e^2 \quad (214)$$

where the effective potential V is given by

$$V^2(J, r) = \left(1 - \frac{2GM}{rc^2}\right)\left(1 + \frac{j^2}{r^2c^2}\right) \quad (215)$$

The expression differs slightly from the one in universal gravity, as you might want to check. One now needs to solve for $r(\varphi)$.

Challenge 247

For *circular* orbits one gets *two* possibilities

Challenge 264

$$r = \frac{6GM/c^2}{1 \pm \sqrt{1 - 12\left(\frac{GM}{cj}\right)^2}} \quad (216)$$

where the minus sign gives a stable orbit, and the plus sign an unstable orbit. If $cj/GM < 2\sqrt{3}$, no stable orbit exists; the object will impact the surface or, for a black hole, be swallowed. There is a stable circular orbit *only* if the angular momentum j is larger than $2\sqrt{3}GM/c$. One notes thus that there is a smallest stable circular orbit, in contrast to universal gravity. The radius of this smallest stable circular orbit is $6GM/c^2 = 3R_S$.

What is the situation for *elliptical* orbits? Setting $u = 1/r$ in (214) and differentiating, the equation for $u(\varphi)$ becomes

$$u' + u = \frac{GM}{j^2} + \frac{3GM}{c^2}u^2 \quad (217)$$

Without the nonlinear correction due to general relativity on the far right, the solutions are the famous *conical sections*

Challenge 281

$$u_o(\varphi) = \frac{GM}{j^2}(1 + \varepsilon \cos \varphi) \quad (218)$$

i.e. ellipses, parabolas, or hyperbolas, depending on the value of the parameter ϵ , the so-called *eccentricity*. We know them from universal gravity. General relativity introduces the nonlinear term in (217). The solutions are not conical sections any more; however, as the correction is small, a good approximation is given by

$$u(\phi) = \frac{GM}{j^2} \left[1 + \epsilon \cos\left(\phi - \frac{3G^2M^2}{j^2c^2}\phi\right) \right] \tag{219}$$

which gives the famous rosetta path of Figure 122. Such a path is first of all characterized by a periastron shift. The *periastron*, or *perihelion* in the case of the sun, is the furthest point reached by an orbiting body. The periastron turns around the central body with an angle

Challenge 315

$$\alpha \approx 6\pi \frac{GM}{a(1 - \epsilon^2)c^2} \tag{220}$$

for every orbit, where a is the *semimajor axis*. The angle has been measured for the orbits of Mercury, Icarus, Venus, and Mars around the sun, and for several binary star systems. In all cases, expression (220) describes the motion within experimental errors. For Mercury, the value is 43 ' per century. This was the only effect unexplained by universal gravity in Einstein's time; when he found exactly that value in his calculation, he was overflowing with joy for many days.

For some time, it was thought that the quadrupole moment of the sun could be an alternative source of this effect; later measurements ruled out this possibility. In binary pulsars, the periastron shift can be as large as several degrees per year.

However, not even the rosetta orbit is really stable in general relativity, because of the emission of gravitational waves. On the other hand, in the solar system, the power lost this way is completely negligible even over thousands of millions of years, as we saw above.

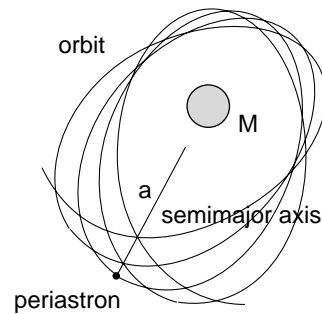

Figure 122 The orbit around a central body in general relativity

The geodesic effect

When a pointed body orbits a central mass m at distance r , the direction of the tip will not be the same after a full orbit. The angle α describing the direction change is given by

$$\alpha = 2\pi \left(1 - \sqrt{1 - \frac{3Gm}{rc^2}} \right) \approx \frac{3\pi Gm}{rc^2} . \tag{221}$$

The result is called the *geodesic effect* – ‘geodetic’ in other languages. It is a further consequence of the split into gravitoelectric and gravitomagnetic fields, as you may want to show. Obviously, it does not exist in universal gravity.

Challenge 332

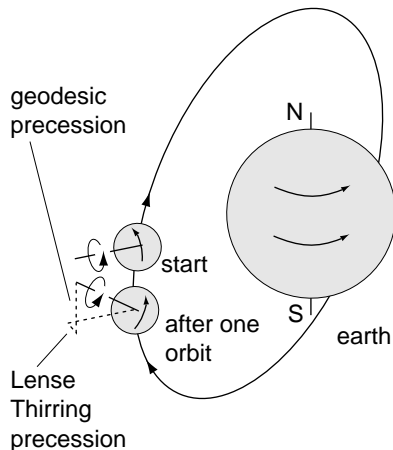

Figure 123 The geodesic effect

The geodesic effect, or geodesic precession, was predicted by de Sitter in 1916; in particular, he proposed to detect the fact that the earth moon-system would change its pointing direction in its fall around the sun. The effect is tiny; for the axis of the moon the precession angle is about 0.019 arcsec per year. The effect was first detected in 1987 by an Italian team for the earth moon system, through a combination of radiointerferometry and lunar ranging, making use of the cat-eyes deposited by the cosmonauts on the moon. Experiments to detect it in artificial satellites are also under way.

We now stop with the discussion of the weak gravity effects and return to the general case of relativistic motion. We now study strong gravity effects, where curvature cannot be neglected, and where there is more fun.

How is curvature measured?

We saw that in the precise description of gravity, motion depends on space-time curvature. In order to add numbers to this idea, we first of all need to describe curvature itself as accurately as possible. To clarify the issue, we will start the discussion in two dimensions, and then go over to three and four dimensions.

Obviously, a flat sheet of paper has no curvature. If one rolls it into a cone or a cylinder, it gets what is called *extrinsic curvature*; however, the sheet of paper still looks flat for any two-dimensional animal living on it – as approximated by an ant walking over it. In other words, the *intrinsic curvature* of the sheet of paper is zero even if the sheet as a whole is extrinsically curved. (Can a one-dimensional space have intrinsic curvature? And what about a torus?)

Intrinsic curvature is thus the stronger concept, measuring the curvature which can be observed even by an ant. The surface of the earth, the surface of an island, or the slopes of a mountain are intrinsically curved. Whenever one talks about curvature in general relativity, one always means *intrinsic* curvature, since any observer in nature is by definition in the same situation as an ant on a surface: their experience, acts and plans always only concern their closest neighbourhood in space and time.

In the case that the pointing of the orbiting body is realized by an intrinsic rotation, such as for a spinning satellite, the geodesic effect produces a *precession* of the axis. Thus the effect is comparable to spin-orbit coupling in atomic theory. (The Thirring-Lense effect mentioned above is analogous to spin-spin coupling.)

At first sight, geodesic precession is similar to the Thomas precession found in special relativity. In both cases, a transport along a closed line results in the loss of the original direction. However, a careful investigation shows that Thomas precession can be *added* to geodesic precession by applying some additional, non-gravitational interaction, so that the analogy is somewhat shaky.

See page 188

Ref. 48

Ref. 49

Challenge 349

But how precisely can an ant determine whether it lives on an intrinsically curved surface? * One way is shown in Figure 124. The ant can check whether either the circumference of a circle or its area fits with the measured radius. She can even use the difference between the two numbers

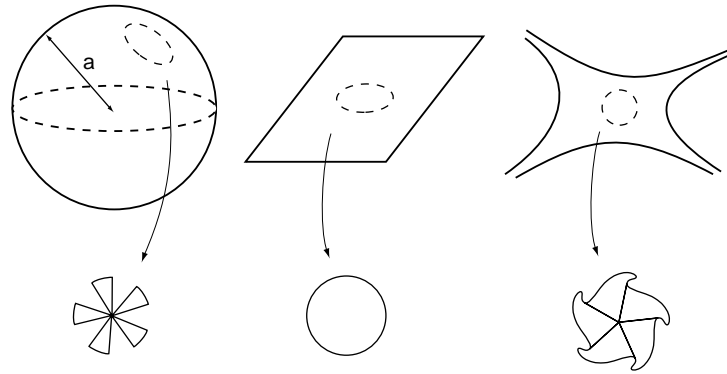

Figure 124 Positive, vanishing and negative curvature in two dimensions

intrinsic curvature, if she takes the limit for vanishingly small circles and if she normalizes the values correctly. In other words, the ant can imagine to cut out a little disk around the point she is on, to iron it flat, and to check whether the disk would tear or produce folds. Any a two-dimensional surface is intrinsically curved whenever ironing is not sufficient to make a street map out of it.

This means that one can recognize intrinsic curvature also by checking whether two parallel lines stay parallel, approach each other, or depart from each other. In the first case, such as lines on a paper cylinder, the surface is said to have *vanishing* intrinsic curvature; a surface with approaching parallels, such as the earth, is said to have *positive* curvature, and a surface with diverging parallels, such as a saddle, is said to have *negative* curvature. In short, positive curvature means that one is locked in, negative that one is locked out. You might want to check this with Figure 124.

Ref. 29 Let us see how to quantify these ideas. First a question of vocabulary: a sphere with radius a is said, by definition, to have an intrinsic curvature $K = 1/a^2$. Therefore, a plane has vanishing curvature. You might check that for a circle on a sphere, the measured radius r , circumference C , and area A are related by

Challenge 366

$$C = 2\pi r(1 - \frac{K}{6}r^2 + \dots) \quad \text{and} \quad A = \pi r^2(1 - \frac{K}{12}r^2 + \dots) \quad (222)$$

where the dots imply higher order terms. This allows to define the intrinsic curvature K , also called the *gaussian* curvature, for a point in two dimensions in either of the following two equivalent ways:

$$K = 6 \lim_{r \rightarrow 0} (1 - \frac{C}{2\pi r}) \frac{1}{r^2} \quad \text{or} \quad K = 12 \lim_{r \rightarrow 0} (1 - \frac{A}{\pi r^2}) \frac{1}{r^2} \quad (223)$$

This expression allows a bug to measure the intrinsic curvature at each point for any smooth surface. ** From now on in this text, *curvature* will always mean *intrinsic* curvature. Note

* Note that the answer to this question also tells how one can distinguish real curvature from curved coordinate systems on a flat space. This question is often put by those approaching general relativity for the first time.

** If the n -dimensional volume of a sphere is written as $V_n = C_n r^n$ and the n -dimensional surface as $O_n = n C_n r^{n-1}$, one can generalize the expressions to

$$K = 3(n+2) \lim_{r \rightarrow 0} (1 - \frac{V_n}{C_n r^n}) \frac{1}{r^2} = 3n \lim_{r \rightarrow 0} (1 - \frac{O_n}{n C_n r^{n-1}}) \frac{1}{r^2} \quad \text{or} \quad (224)$$

that the curvature can be different from place to place, and that it can be positive, like for an egg, or negative, like the inside of any torus. Also a saddle is an example for the latter case, but, unlike the torus, with a curvature *changing* from point to point. In fact, it is not possible at all to fit a surface of *constant* negative curvature inside three-dimensional space; one needs at least four dimensions, as you can find out if you try to imagine the situation.

Challenge 400

Note that for any surface, at any point, the direction of maximum curvature and the direction of minimum curvature are always *perpendicular* to each other. This fact was discovered by Leonhard Euler in the 18th century. You might want to check this with a tea cup, or with a sculpture by Henry Moore, or with any other curved object from your surroundings, such as a Volkswagen beetle. The gaussian curvature is in fact the product of the two corresponding inverse curvature radii. Thus, even though line curvature is not intrinsic, this special product is. Physicists are thus particularly interested in gaussian curvature – and its higher-dimensional analogies.

Challenge 417

For *three-dimensional* objects, the issue is a bit more involved. Obviously, we have difficulties imagining the situation. But we can still ‘see’ that the curvature of a small disk around a point will depend on its orientation. But let us first look at the simplest case. If the curvature at a point is the same in all directions, the point is called *isotropic*. One then can imagine a small sphere around that point. In this special case, in three dimensions, the relation between the measured radius and the measured sphere surface A leads to define the curvature

Challenge 434

$$K = 9 \lim_{r \rightarrow 0} \left(1 - \frac{A}{4\pi r^2}\right) \frac{1}{r^2} = 18 \lim_{r \rightarrow 0} \frac{r - \sqrt{A/4\pi}}{r^3} = 18 \lim_{r \rightarrow 0} \frac{r_{\text{excess}}}{r^3} . \quad (225)$$

Defining the *excess radius* as $r - \sqrt{A/4\pi}$, one gets that for a three-dimensional space, *the curvature is eighteen times the excess radius of a small sphere divided by the cube of its radius*. A positive curvature is equivalent to a positive excess radius, and similarly for vanishing and negative cases.

Of course, this value is only an average. The precise way requires to define curvature with disks; these values will *differ* from the values calculated by using the sphere, as they will depend on the *orientation* of the disk. However, all possible disk curvatures at a given point are related among each other and must form a tensor. (Why?) For a full description of curvature, one thus has to specify, as for any tensor in three dimensions, the main curvatures in three orthogonal directions.*

Challenge 451

What are the numbers in practice? Already in 1827, the mathematician and physicist Friedrich Gauss checked whether the three angles between three mountain peaks near where he lived added up to π . Nowadays we know that the deviation δ from the angle π on the surface of a body of mass M and radius r is given by

$$\delta = \pi - (\alpha + \beta + \gamma) \approx A_{\text{triangle}} \frac{GM}{r^3 c^2} . \quad (226)$$

Challenge 383 as shown by Vermeil. A famous riddle is to determine C_n .

* These three disk values are not independent however, since together, they must yield the just mentioned average volume curvature K . In total, there are thus *three* independent scalars describing the curvature in three dimensions (at each point). With the metric tensor g_{ab} and the Ricci tensor R_{ab} to be introduced below, one choice is to take for the three independent numbers the values $R = -2K$, $R_{ab}R^{ab}$, and $\det R/\det g$.

For the case of the earth and typical mountain distances, one gets an angle of the order of 10^{-14} rad. Gauss had no chance to detect any deviation, and in fact he didn't. But Gauss did not know, as we do today, that gravity and curvature go hand in hand. Even with lasers and high precision set-ups, no deviation has been detected yet – on earth. The right-hand factor, which measures the curvature of space-time on the surface of the earth, is too small.

Curvature and space-time

In nature, with *four* space-time dimensions, the situation requires a more involved approach. First of all, the use of space-time coordinates automatically introduces the speed of light c as limit speed, which is the main requirement leading to general relativity. Furthermore, the number of dimensions being four, we expect a value for an average curvature at a point, defined by comparing the 4-volume of a 4-sphere in space-time and with the one deduced from the measured radius; then we expect a set of 'almost average' curvatures defined by 3-volumes of 3-spheres in various orientations, plus a set of 'low-level' curvatures defined by usual 2-areas of usual 2-disks in even more orientations. Obviously, we need to bring some order in this set, and we need to avoid the double counting we already encountered in the case of three dimensions.

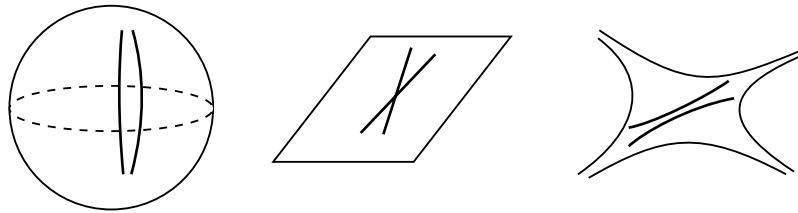

Figure 125 Curvature (in two dimensions) and geodesic behaviour

Fortunately, physics can help to make the mathematics easier. First of all, however, we need to define what we mean by curvature of space-time. Then we will define curvatures for disks of various orientations. To achieve this, we translate the definition of curvature into another picture, which allows to generalize it to time as well. Figure 125 shows that the curvature K also describes how geodesics *diverge*. Geodesics are the straightest paths on a surface, i.e. those paths that a tiny car or tricycle would follow if it drives on the surface keeping the steering wheel straight.

Challenge 468 If a space is curved, the separation s will increase along the geodesics as

$$\frac{d^2s}{dl^2} = -Ks + \text{higher orders} \quad (227)$$

where l measures the length along the geodesic, and as above K is the inverse square curvature radius.

In space-time, this is extended by substituting proper length with proper time (times the speed of light). Thus the curvature becomes:

$$\frac{d^2s}{d\tau^2} = -Kc^2s + \text{higher orders} \quad (228)$$

This turns out to be the definition of an acceleration. In other words, what in the purely spatial case is described by *curvature*, in the case of space-time becomes the *relative acceleration* of two particles freely falling from the same point. But we encountered these accelerations already: they describe tidal effects. In short, space-time curvature and tidal effects are precisely the same!

See page 93

Obviously, the value of tidal effects and thus of curvature will depend on the orientation – more precisely on the orientation of the space-time plane formed by the two particle velocities. But the definition also shows that K is a tensor, and that later on we will have to add indices to it. (How many?) The fun is that we can avoid indices for a while by looking at a special combination of spatial curvatures. If we take three planes in space, all orthogonal to each other and through the same point, the *sum* of the three curvature values does *not* depend on the observer. (This corresponds to the tensor trace.) Can you show this, by using the definition of the curvature just given?

Challenge 485
Ref. 30

The sum of all three such curvatures defined for mutually orthogonal planes, called *sectional curvatures* in this context and written $K_{(12)}$, $K_{(23)}$, and $K_{(31)}$, is related to the excess radius defined above. Can you find out how?

Challenge 502

If a surface has *constant* (intrinsic) curvature, i.e. the same curvature at all locations, geometrical objects can be moved around without deforming them. Can you picture this?

Challenge 519

In summary, curvature is not such a difficult concept. It describes the *deformation* of space-time. If one imagines space (-time) as a big blob of rubber in which we live, the curvature at a point describes how this blob is squeezed at that point. Since we live *inside* the rubber, we need to use ‘insider’ methods, such as excess radii and sectional curvatures, to describe the deformation. Relativity is only difficult to learn because people often do not like to think about the vacuum in this way, and even less to explain it in this way. (For a hundred years it was a question of faith for every physicist to say that the vacuum is empty.) But that is slowly changing.

Curvature and motion in general relativity

As mentioned above, one half of general relativity says that any object moves along paths of *maximum* proper time, i.e. along geodesics. All of the *other* half is contained in a single expression: The sum of all three *proper* sectional *spatial* curvatures at a point is given by

$$K_{(12)} + K_{(23)} + K_{(31)} = \frac{8\pi G}{c^4} W^{(0)} \quad (229)$$

where $W^{(0)}$ is the *proper* energy density at the point, *and* this statement is valid for *every* observer. That is general relativity in one paragraph.

An equivalent way to describe the expression is easily found using the excess radius defined above, and introducing the mass M by $M = VW^{(0)}/c^2$. One gets

Challenge 536

$$r_{\text{excess}} = r - \sqrt{A/4\pi} = \frac{G}{3c^2} M \quad (230)$$

In short, relativity says that for every observer, *the excess radius of a small sphere is given by the mass inside the sphere.* *

Note that the expression means that the average space curvature at a point in empty space *vanishes*. As we will see shortly, this means that near a spherical mass the curvature *towards* the mass and twice the curvature *around* the mass exactly compensate each other.

Curvature will also differ from point to point. In particular, the expression implies that if energy *moves*, curvature will move with it. In short, both space curvature, and, as we will see shortly, space-time curvature *change* over space and time.

We note in passing that curvature has an annoying effect: the relative velocity of *distant* observers is undefined. Can you provide the argument? Relative velocity is defined only for *nearby* objects – in fact for objects with no distance at all.

The quantities appearing in expression (229) are *independent* of the observer. But often people want to use observer-dependent quantities. The relation then gets more involved; the single equation (229) must be expanded to ten equations, called *Einstein's field equations*. They will be introduced below. But before we do that, we check that general relativity makes sense. We skip the check that it contains special relativity as limiting case, and directly go to the main test.

Universal gravity

The only reason which keeps me here is gravity.
Anonymous

Challenge 553

For small velocities, one finds that the temporal curvatures (227) can be defined as the second spatial derivatives of a single scalar function ϕ via

$$K_{(0j)} = \frac{\partial^2 \phi}{\partial (x^j)^2} \quad (232)$$

Universal gravity is the description for small speeds and small spatial curvature. Both limits imply, taking $W^{(0)} = \rho c^2$ and using $c \rightarrow \infty$, that

$$K_{(ij)} = 0 \quad \text{and} \quad \mathbf{K}_{(01)} + \mathbf{K}_{(02)} + \mathbf{K}_{(03)} = 4\pi G\rho \quad . \quad (233)$$

In other words, for slow speeds, space is flat, and the potential obeys Poisson's equation. Universal gravity is thus indeed the limit of general relativity.

Challenge 570

Can you show that expression (229) indeed means that time near a mass depends on the height, as stated in the beginning of this chapter?

The Schwarzschild metric

Ref. 30 What is the curvature of space-time near a spherical mass?

Ref. 31 * Another, equivalent way is to say that for small radii

$$A = 4\pi r^2 \left(1 + \frac{1}{9} r^2 R\right) \quad (231)$$

where R is the Ricci scalar to be introduced later on.

– CS – to be inserted – CS –

The curvature of the Schwarzschild metric is given by

Challenge 587

$$\begin{aligned} K_{r\varphi} = K_{r\theta} &= -\frac{GM}{c^2 r^3} & \text{and} & & K_{\theta\varphi} &= 2\frac{GM}{c^2 r^3} \\ K_{t\varphi} = K_{t\theta} &= \frac{GM}{c^2 r^3} & \text{and} & & K_{tr} &= -2\frac{GM}{c^2 r^3} \end{aligned} \quad (234)$$

everywhere. The dependence on $1/r^3$ follows from the general dependence of all tidal effects; we had calculated them in the chapter on universal gravity. The factors c^2 follow from space-time, and only the numerical prefactors need to be calculated from general relativity. The average curvature obviously vanishes. As expected, the values of the curvatures near the surface of the earth is exceedingly small.

Ref. 30

See page 93

Curiosities and fun challenges

▪ A fly has landed on the outside of a cylindrical glass, 1 cm below its rim. A drop of honey is located halfway around the glass, also on the outside, 2 cm below the rim. What is the shortest distance to the drop?

Challenge 604

What is the shortest distance, if the drop is on the *inside* of the glass?

Challenge 621

– CS – more to come – CS –

All observers: heavier mathematics

Jeder Straßenjunge in unserem mathematischen Göttingen versteht mehr von vierdimensionaler Geometrie als Einstein. Aber trotzdem hat Einstein die Sache gemachte, und nicht die großen Mathematiker.
David Hilbert*

Now that we have a feeling for curvature, we want to describe it in a way that allows *any* observer to talk to any *other* observer.** Unfortunately, this means to use formulas with tensors. These formulas look exactly the way that non-scientists imagine: daunting. The challenge is to be able to see in each of the expressions the essential point (e.g. by forgetting all indices for a while) and not to be impressed by those small letters sprinkled all over them.

The curvature of space-time

We mentioned above that a 4-dimensional space-time is described by 2-curvature, 3-curvature, and 4-curvature. Many texts on general relativity start with 3-curvature. These curvatures describing the distinction between the 3-volume calculated from a radius and the actual 3-volume. They are described by the *Ricci tensor*. With an argument we encountered

* Every street boy in our mathematical Göttingen knows more about four-dimensional geometry than Einstein. Nevertheless, it was Einstein who did the work, not the great mathematicians.

** This section might be skipped at first reading. The section on cosmology, on page 290, then is the right point to continue.

already for the case of geodesic deviation, it turns out that the Ricci tensor describes how the shape of a spherical cloud of freely falling particles is deformed on its path.

– CS – a bit more in the next version – CS –

In short, the Ricci tensor is the general relativistic version of $\Delta\phi$, or better, of $\square\phi$.

Obviously, the most global, but least detailed description of curvature is the one describing the distinction between the 4-volume calculated from a measured radius and the actual 4-volume. This is the *average curvature* at a space-time point and is described by the so-called *Ricci scalar* R defined as

$$R = -2K = -\frac{2}{r_{\text{curvature}}^2} . \quad (235)$$

It turns out that the Ricci scalar can be derived from the Ricci tensor by a so-called *contraction*, the name for the precise averaging procedure needed. For tensors of rank two, contraction is the same as the taking of the trace:

$$R = R^\lambda{}_\lambda = g^{\lambda\mu} R_{\lambda\mu} . \quad (236)$$

The Ricci scalar, describing the curvature averaged over space *and* time, always vanishes in vacuum. This allows for example, on the surface of the earth, to relate the spatial curvatures and the changes of time with height.

Challenge 638

Now comes one of the issues discovered by Einstein in two years of hard work. The quantity of importance for the description of curvature in nature is not the Ricci tensor R , but a tensor built from it. This *Einstein tensor* G is defined mathematically (for vanishing cosmological constant) as

$$G_{ab} = R_{ab} - \frac{1}{2} g_{ab} R \quad (237)$$

It is not difficult to get its meaning. The value G_{00} is the sum of sectional curvatures in the planes *orthogonal* to the 0 direction, and thus the sum of all spatial sectional curvatures:

$$G_{00} = K_{(12)} + K_{(23)} + K_{(31)} \quad (238)$$

Similarly, the diagonal elements G_{ii} are the sum (taking into consideration the minus signs of the metric) of sectional curvatures in the planes *orthogonal* to the i direction. For example, one has:

$$G_{11} = K_{(02)} + K_{(03)} - K_{(23)} . \quad (239)$$

The other components are defined accordingly. The distinction between the Ricci tensor and the Einstein tensor is thus the way in which the sectional curvatures are combined: disks *containing* the coordinate in question in one case, disks *orthogonal* to the coordinate in the other case. Both describe the curvature of space-time equally, and fixing one means fixing the other. (What is the trace of the Einstein tensor?)

Challenge 655

The Einstein tensor is symmetric, which means that it has *ten* independent components. Most importantly, its divergence vanishes; it therefore describes a conserved quantity. And this was the key property which allowed Einstein to relate it to mass and energy in mathematical language.

The description of momentum, mass and energy

Obviously, for a complete description of gravity, also the motion of momentum and energy needs to be quantified in such a way that any observer can talk to any other. We have seen that momentum and energy always appear together in relativistic descriptions; the next step is thus to find out how this needs to be done in detail.

First of all, the quantity describing energy, let us call it T , must be defined using the energy-momentum vector $\mathbf{p} = m\mathbf{u} = (\gamma m, \gamma \mathbf{v})$ of special relativity. Furthermore, T does not describe a single particle, but the way energy-momentum is distributed over space and time. As a consequence, it is most practical to use T to describe a *density* of energy and momentum. T will thus be a *field*, and depend on time and space, a fact usually written as $T = T(t, x)$.

Since T describes a density over space and time, it defines, at every space-time point, and for every infinitesimal surface $d\mathbf{A}$ around that point, the flow of energy-momentum $d\mathbf{p}$ through that surface. In other words, T is defined by the relation

$$d\mathbf{p} = T d\mathbf{A} \quad . \quad (240)$$

The surface is assumed to be characterized by its normal vector $d\mathbf{A}$. Since the energy-momentum density is a proportionality factor between two vectors, T is a *tensor*. Of course, we are talking about 4-flows and 4-surfaces here. Thus the tensor can be split in the following way:

$$T = \left(\begin{array}{c|ccc} w & S_1 & S_2 & S_3 \\ \hline S_1 & t_{11} & t_{12} & t_{13} \\ S_2 & t_{21} & t_{22} & t_{23} \\ S_3 & t_{31} & t_{32} & t_{33} \end{array} \right) = \left(\begin{array}{c|ccc} \text{energy} & & & \\ \text{density} & & & \\ \hline \text{energy flow or} & & & \\ \text{momentum density} & & & \end{array} \begin{array}{c} \text{energy flow density, or} \\ \text{momentum density} \\ \hline \text{momentum} \\ \text{flow density} \end{array} \right) \quad (241)$$

where $w = T_{00}$ is a 3-scalar, \mathbf{S} a 3-vector, and t a 3-tensor. The total quantity T , the so called *energy-momentum tensor*, has two essential properties. It is symmetric, and its divergence vanishes.

The vanishing divergence, often written as

$$\partial_a T^{ab} = 0 \quad \text{or abbreviated} \quad T^{ab}{}_{,a} = 0 \quad (242)$$

expresses that the tensor describes a *conserved* quantity. In every volume, energy can change only through flow through its boundary. Can you confirm that the description of energy-momentum with this tensor follows the requirement that any two observers, differing by position, orientation, speed *and* acceleration, can communicate their results to each other? Challenge 672

The energy-momentum tensor gives a full description of the distribution of energy, momentum, and mass over space and time. As an example, let us determine the energy-momentum density for a moving liquid. For a liquid of density ρ , a pressure p and a 4-velocity \mathbf{u} , one has

$$T^{ab} = (\rho_0 + p)u^a u^b - pg^{ab} \quad . \quad (243)$$

Here, ρ_0 is the density measured in the comoving frame, the so-called *proper* density.* Obviously, ρ , ρ_0 , and p depend on space and time.

Of course, for a particular material fluid, one needs to know how pressure and density are related. A full material characterization thus requires the knowledge of the relation

$$p = p(\rho) \quad (245)$$

which is a material property and thus cannot be determined from relativity. It has to be derived from the constituents of matter or radiation and their interactions. The simplest possible case is *dust*, i.e. matter made of point particles with no interactions at all. Its energy-momentum tensor is given by

$$T^{ab} = \rho_0 u^a u^b \quad (246)$$

Challenge 689 Can you explain the difference to the liquid case?

Challenge 706 The divergence of the energy-momentum vanishes identically, as you may want to check. This property is the same as for the Einstein tensor presented above. But before we elaborate on the issue, a short remark. Why don't we take account of *gravitational energy*? It turns out that gravitational energy cannot be defined in general. Gravity is *not* an interaction, and does *not* have an associated energy.**

The symmetry of general relativity

– CS – To be written – CS –

By the way, Torre has shown that diffeomorphism symmetry and trivial scale symmetry are the *only* symmetries of the vacuum field equations.

Mass and ADM

The diffeomorphism invariance of general relativity makes life quite annoying. We will see that it allows to say that we live on the *inside* of a hollow sphere, and that it does not allow to say where energy actually is located. If energy cannot be located, what about mass? It became clear that mass, or energy, can be localized *only* if space-time far away from it is known to be flat. It is then possible to define a localized mass value by the following intuitive idea: the mass is measured by the time a probe takes to orbit the unknown body.

* In the *comoving* frame one thus has

$$T^{ab} = \begin{pmatrix} \rho_0 c^2 & 0 & 0 & 0 \\ 0 & p & 0 & 0 \\ 0 & 0 & p & 0 \\ 0 & 0 & 0 & p \end{pmatrix} . \quad (244)$$

** In certain special circumstances, such as weak fields, slow motion, or an asymptotically space-time, one *can* define the integral over the G^{00} component of the Einstein tensor as negative gravitational energy. Gravitational energy is only defined *approximately*. This approximation leads to the famous speculation that the total energy of the universe is zero. Do you agree?

See page 305
Challenge 723

This definition was formalized by Arnowitt, Deser, and Misner, and since then is often called the *ADM mass*. Obviously, this approach *requires* flat space-time at infinity, and cannot be extended to other situations. In short, *mass* is defined only for asymptotically flat space-time.

Challenge 740

Now that we can go on talking about mass without (too much) a bad conscience, we turn to the equations of motion.

Ref. 94

Hilbert's action

When Einstein discussed his work with David Hilbert, Hilbert found a way to do in a few weeks what Einstein had done in years. Hilbert understood that general relativity *in empty space* could be described by an action integral, like all other physical systems.

Thus Hilbert set of to find the measure of change, as this is what an action describes, for motion due to gravity. Obviously, the measure must be observer invariant; in particular, it must include all changes of viewpoints possible, i.e. all the symmetries just described.

Motion due to gravity is determined by curvature. The only curvature measure independent of the observer is the Ricci scalar R . It thus makes sense to expect that the change of space-time is described by an action

$$S = \frac{c^3}{16\pi G} \int (R + 2\Lambda) dV \quad . \quad (247)$$

The cosmological constant Λ (added some years later) appears as a mathematical possibility to describe the most general diffeomorphism invariant action. We will see below that its value, though small, seems to be different from zero.

– CS – to be finished – CS –

Einstein's field equations

[Einstein's general theory of relativity]
cloaked the ghastly appearance of atheism.
A US-American sorcerer

Do you believe in god? Prepaid reply 50 words.
Subsequent telegram by a competing
sorcerer to his hero Albert Einstein

I believe in Spinoza's god, who reveals himself in
the orderly harmony of what exists, not in a god who
concerns himself with fates and actions of human beings.

Albert Einstein's answer

At the basis of all these worries were Einstein's famous field equations. They contain the full description of general relativity and are simply given by

$$G_{ab} = -\kappa T_{ab}$$

or

$$R_{ab} - \frac{1}{2}g_{ab}R = -\kappa T^{ab} - \Lambda g_{ab} \quad . \quad (248)$$

The constant κ , called the *gravitational coupling constant*, has been measured to be

$$\kappa = \frac{8\pi G}{c^4} = 2.1 \cdot 10^{-43} \text{ /N} \quad (249)$$

and its small value reflects the weakness of gravity in everyday life, or better, the difficulty to bend space-time. The constant Λ , the so-called *cosmological constant*, corresponds to a vacuum energy volume density or pressure Λ/κ . It is quite hard to measure. The presently favoured value is

See page 295

$$\Lambda \approx 10^{-52} \text{ /m}^2 \quad \text{or} \quad \Lambda/\kappa \approx 0.5 \text{ nJ/m}^3 = 0.5 \text{ nPa} \quad . \quad (250)$$

In summary, the field equations state that the curvature at a point is equal to the flow of energy-momentum through that point, taking into account the vacuum energy density. In short, *energy-momentum tells space-time how to curve*.*

The field equations of general relativity can be simplified for the case that speeds are small. In that case $T_{00} = \rho c^2$ and all other components of T vanish. Using the definition of κ and setting $\phi = (c^2/2)h_{00}$ in $g_{ab} = \eta_{ab} + h_{ab}$, one finds

Challenge 757

$$\nabla^2 \phi = 4\pi\rho \quad \text{and} \quad \frac{d^2x}{dt^2} = -\nabla\phi \quad (251)$$

* Einstein arrived at his field equations using a number of intellectual guidelines called *principles* in the literature. Today, many of them are not seen as central any more; here is a short overview.

- *Principle of general relativity*: all observers are equivalent; this principle, even though often stated, is probably empty of any physical content.

Ref. 33

- *Principle of general covariance*: the equations of physics must be stated in tensorial form; even though it is known today that all equations can be written with tensors, even universal gravity, in many cases they require unphysical 'absolute' elements, i.e. quantities which affect others but are not affected themselves. This unphysical idea is in contrast with the idea of *interaction*, as explained above.

See page 456

- *Principle of minimal coupling*: the field equations of gravity are found from those of special relativity by taking the simplest possible generalization. Of course, now that the equations are known and tested experimentally, this principle is only of historical interest.

- *Equivalence principle*: acceleration is locally indistinguishable from gravitation; we used it to argue that space-time is semi-Riemannian, and that gravity is its curvature.

- *Mach's principle*: inertia is due to the interaction with the rest of the universe; this principle is correct, even though it is often maintained that it is not fulfilled in general relativity. In any case, it is not the essence of general relativity.

See page 307

- *Identity of gravitational and inertial mass*: this is included into the definition of mass from the outset, but restated ad infinitum in general relativity texts; it is implicitly used in the definition of the Riemann tensor.

- *Correspondence principle*: a new, more general theory, such as general relativity, must reduce to the previous theory, in this case universal gravity or special relativity, when restricted to the domains in which those are valid.

which we know well, since it can be restated as follows: a body of mass m near a body of mass M is accelerated by

$$a = G \frac{M}{r^2} \quad (252)$$

a value which is independent of the mass m of the falling body. And indeed, as noted already by Galileo, all bodies fall with the same acceleration, independently of their size, their mass, their colour, etc. Also in general relativity, gravitation is completely democratic.*

To get a feeling for the complete field equations, we have a short walk through their main properties.

First of all, all motion due to space-time curvature is *reversible*, *differentiable* and thus *deterministic*. Note that only the complete motion, of space-time *and* matter *and* energy, has these properties. For particle motion only, motion is in fact *irreversible*, as in most examples of motion, some gravitational radiation is emitted.

Challenge 774

By contracting the field equations one finds, for vanishing cosmological constant, the following expression for the Ricci scalar

$$R = -\kappa T \quad (257)$$

This result also implies the relation between the excess radius and the mass inside a sphere.

Challenge 791

The field equations are *nonlinear* in the metric g , meaning that sums of solutions are *not* solutions. That makes the search for solutions rather difficult. For a complete solution of the field equations, initial and boundary conditions should be specified. The ways to do this form a specialized part of mathematical physics, which is not studied here.**

Albert Einstein used to say that the general relativity only provides the understanding of one side of the field equations, but not of the other. Can you see which one he meant?

Challenge 808

What can we do of interest with these equations? In fact, to be honest, not much that we have not done already. Very few processes require the use of the full equations. Many

* Here is another way to show that general relativity fits with universal gravity. From the definition of the Riemann tensor we know that relative acceleration b_a and speed of nearby particles are related by

$$\nabla_e b_a = R_{ceda} v^c v^d \quad (253)$$

From the symmetries of R we know there is a φ such that $b_a = -\nabla_a \varphi$. That means that

$$\nabla_e b^a = \nabla_e \nabla^a \varphi = R_{ced}^a v^c v^d \quad (254)$$

which implies that

$$\begin{aligned} \Delta \varphi &= \nabla_a \nabla^a \varphi = R_{cad}^a v^c v^d \\ &= R_{cd} v^c v^d \\ &= \kappa (T_{cd} v^c v^d - T/2) \end{aligned} \quad (255)$$

Introducing $T_{ab} = \rho v_a v_b$ one gets

$$\Delta \varphi = 4\pi G \rho \quad (256)$$

as we wanted to show.

** For more mathematical details, see the famous three-women-book in two volumes by YVONNE CHOQUET-BRUHAT, CECILE DEWITT-MORETTE & MARGARET DILLARD-BLEICK, *Analysis, manifolds, and physics*, North-Holland, 1996 and 2001, even though the first edition of this classic appeared in 1977.

textbooks on relativity even stop after writing them down! However, studying them is worthwhile. For example, one can show that the Schwarzschild solution is the *only* spherically symmetric solution. Similarly, in 1923, Birkhoff showed that every rotationally symmetric vacuum solution is static. That is the case even if masses themselves move, as for example during the collapse of a star.

In fact, maybe the most beautiful application of the field equations are the various *movies* made of relativistic processes. The world wide web provides several of them; they allow to see what happens when two black holes collide, what happens when an observer falls into a black hole, etc. For these movies, the field equations usually need to be solved directly, without approximations. *

– CS – more to be added – CS –

Another topic concerns *gravitational waves*. The full field equations show that waves are not harmonic, but nonlinear. Sine waves exist only approximately, for small amplitudes. Even more interestingly, if two waves collide, in many cases *singularities* are predicted to appear. The whole theme is still a research topic, and might provide new insights for the quantization of general relativity in the coming years.

We end this section with a side note. Usually, the field equations are read in one sense only, as stating that energy-momentum produce curvature. One can also read them in the other way, calculating the energy-momentum needed to produce a given curvature. When one does this, one discovers that not all curved space-times are possible, as some would lead to *negative* energy (or mass) densities. Such solutions would contradict the mentioned limit on size to mass ratio for physical systems. The limit on length to mass ratios thus also restricts the range of possible curvatures of space-time.

How to calculate the shape of geodesics

The other half of general relativity states that bodies fall along geodesics. All orbits are geodesics, thus curves with the longest proper time. It is thus useful to be able to calculate these trajectories. ** To start, one needs to know the *shape of space-time*, that is the generalization of the shape of a two-dimensional surface. For a being living on the surface, it is usually described by the metric g_{ab} , which defines the distances between neighbouring points through

$$ds^2 = dx_a dx^a = g_{ab}(x) dx^a dx^b . \quad (258)$$

It is a famous exercise of calculus to show from this expression that a curve $x^a(s)$ depending on a well behaved (affine) parameter s is a timelike or spacelike (metric) *geodesic*, i.e. the longest possible path between the two events, only if

Challenge 825

$$\frac{d}{ds} \left(g_{ad} \frac{dx^d}{ds} \right) = \frac{1}{2} \frac{\partial g_{bc}}{\partial x^a} \frac{dx^b}{ds} \frac{dx^c}{ds} , \quad (259)$$

* See for example, the math1.uibk.ac.at/~werner/black-earth web site.

** This is a short section for the more curious; it can be skipped at first reading.

as long as ds is different from zero along the path.* All bodies in free fall follow such geodesics. We showed above that the geodesic property implies that a stone thrown in the air falls back, except if it is thrown with a speed larger than the escape velocity. Expression (259) thus replaces both the expression $d^2x/dt^2 = -\nabla\phi$ valid for falling bodies and the expression $d^2x/dt^2 = 0$ valid for freely floating bodies in special relativity.

See page 244

The path does not depend on the mass or on the material of the body. Therefore also *antimatter* falls along geodesics. In other words, antimatter and matter do not repel; they also attract each other. Interestingly, even experiments performed with normal matter can show this, if they are carefully evaluated. Are you able to find out why, using the details of the collision?

Ref. 52

Challenge 842

For completion, we mention that light follows *lightlike* or *null geodesics*, an affine parameter u exists, and the geodesics follow

$$\frac{d^2x^a}{d^2u} + \Gamma_{bc}^a \frac{dx^b}{du} \frac{dx^c}{du} = 0 \quad (263)$$

with the different condition

$$g_{ab} \frac{dx^a}{du} \frac{dx^b}{du} = 0 \quad . \quad (264)$$

Given all these definitions of various types of geodesics, what are the lines drawn in Figure 113 on page 240?

Challenge 859

Is gravity an interaction?

One tends to answer affirmatively, as in Galilean physics gravity was seen as an influence on the motion of bodies. In fact, it was described by a potential, meaning that gravity *produces* motion. But let us be careful. A force or an interaction is what changes the motion of objects. However, we just saw that when two bodies attract each other through gravitation, both always remain in free fall. For example, the moon circles the earth because it continuously falls around it. Since any freely falling observer continuously remains at rest, the statement that gravity changes the motion of bodies is not correct for all observers. Indeed, we will soon discover that in a sense to be discussed shortly, the moon and the earth both follow 'straight' paths.

* This is often written as

$$\frac{d^2x^a}{d^2s} + \Gamma_{bc}^a \frac{dx^b}{ds} \frac{dx^c}{ds} = 0 \quad (260)$$

where the condition

$$g_{ab} \frac{dx^a}{ds} \frac{dx^b}{ds} = 1 \quad (261)$$

must be fulfilled, thus simply requiring that all the tangent vectors are *unit* vectors, and that $ds \neq 0$ all along the path. The symbols Γ appearing above turn out to be defined as

$$\Gamma_{bc}^a = \left\{ \begin{matrix} a \\ bc \end{matrix} \right\} = \frac{1}{2} g^{ad} (\partial_b g_{dc} + \partial_c g_{db} - \partial_d g_{bc}) \quad , \quad (262)$$

and are called *Christoffel symbols of the second kind* or simply the *metric connection*.

Is this correction of our idea of gravity only a question of words? Not at all. Since gravity is not a force, it is *not* due to a field, and there is *no* potential.

See page 455

Let us check this strange result in yet another way. The most fundamental definition of ‘interaction’ is the difference between the whole and the sum of its parts. In the case of gravity, an observer in free fall could claim that nothing special is going on, independently of whether the other body is present or not, and could claim that gravity is not an interaction.

However, that is going too far. An interaction transports energy between systems. We indeed found out that gravity can be said to transport energy only approximately. Gravitation is thus an interaction only approximately. But that is a sufficient reason to keep this characterization. In agreement with the strange conclusion, it turned out that the concept of energy is not useful for gravity outside of everyday life. For the general case, namely for a general observer, gravity is thus fundamentally different from electricity or magnetism.

Another way to look at the issue is the following. Take a satellite orbiting Jupiter with energy-momentum $\mathbf{p} = m\mathbf{u}$. If one calculates the energy-momentum change along its path s , one gets

Challenge 876

$$\frac{d\mathbf{p}}{ds} = m \frac{d\mathbf{u}}{ds} = m \left(\mathbf{e}_a \frac{d\mathbf{u}^a}{ds} + \frac{d\mathbf{e}_a}{ds} \mathbf{u}^a \right) = m \mathbf{e}_a \left(\frac{d\mathbf{u}^a}{ds} + \Gamma_{bd}^a \mathbf{u}^b \mathbf{u}^c \right) = 0 \quad (265)$$

where \mathbf{e} describes the unit vector along a coordinate axis. The energy-momentum change vanishes along any geodesic, as you might check. Therefore, the energy-momentum of this motion is conserved. In other words, *no* force is acting on the satellite. One could reply that in equation (265) the second term alone is the gravitational force. But the term can be made to vanish identically along any given world line. In short, nothing changes between two bodies in free fall around each other: gravity could be said not to be an interaction. The properties of energy confirm this argument.

Challenge 893

Ref. 51

Challenge 910

Challenge 927

Of course, the conclusion that gravity is not an interaction is somewhat academic, as it contradicts daily life. But we will need it for the full understanding of motion later on.

The behaviour of radiation confirms the deduction. In vacuum, radiation is always moving freely. In a sense, one can say that radiation always is in free fall. Strangely, since we called free fall the same as rest, we should conclude that radiation always is at rest. This is not wrong! We already saw that light cannot be accelerated.* We even saw that gravitational bending is not an acceleration, since light follows straight paths in space-time in this case as well. Even though light seems to slow down near masses for far away observers, it always moves at the speed of light locally. In short, even gravitation doesn’t manage to move light.

There is another way to show that light is always at rest. A clock for an observer trying to reach the speed of light goes slower and slower. For light, in a sense, time stops: if one prefers, *light does not move*.

* Refraction, the slowdown of light inside matter is a consequence of light-matter interactions, and is not a counterargument, as strictly speaking, light inside matter is constantly being absorbed and reemitted. In between, it still propagates with the speed of light in vacuum. The whole process only *looks* like acceleration in the macroscopic limit. The same applies to diffraction and to reflection. A list of apparent ways to bend light can be found on page 368; details of the quantum mechanical processes at their basis can be found on page 500.

Riemann gymnastics

Most books introduce curvature the hard way, namely historically,* using the Riemann curvature tensor. This is a short summary, so that you can understand that old stuff when you get it in your hands.

Above we saw that curvature is best described by a tensor. In 4 dimensions, this curvature tensor, usually called R , must be a quantity which allows to calculate, among others, the area for any orientation of a 2-disk in space-time. Now, in four dimensions, orientations of a disk are defined with *two* 4-vectors; let us call them \mathbf{p} and \mathbf{q} . And instead of a disk, we take the *parallelogram* spanned by \mathbf{p} and \mathbf{q} . There are several possible definitions.

Challenge 944

The *Riemann-Christoffel curvature tensor* R is then defined as a quantity allowing to calculate the curvature $K(\mathbf{p}, \mathbf{q})$ for the surface spanned by \mathbf{p} and \mathbf{q} , with area A , through

$$K(\mathbf{p}, \mathbf{q}) = \frac{R \mathbf{p} \mathbf{q} \mathbf{p} \mathbf{q}}{A^2(\mathbf{p}, \mathbf{q})} = \frac{R_{abcd} p^a q^b p^c q^d}{(g_{\alpha\delta} g_{\beta\gamma} - g_{\alpha\gamma} g_{\beta\delta}) p^\alpha q^\beta p^\gamma q^\delta} \quad (266)$$

where, as usual, Latin indices a, b, c, d , etc. run from 0 to 3, as do Greek indices here, and a *summation* is implied when an index name appears twice. Obviously R is a tensor, of rank 4. This tensor thus describes the *intrinsic* curvature of a space-time *only*. In contrast, the metric g describes the complete *shape* of the surface, not only the curvature. The curvature is thus the physical quantity of relevance locally, and physical descriptions therefore use only the *Riemann** tensor* R or quantities derived from it.***

But we can forget the just mentioned definition of curvature. There is a second, more physical way to look at the Riemann tensor. We know that curvature means gravity. As said above, gravity means that when two nearby particles move freely with the same velocity and the same direction, the distance between these two particles changes. In other words, the local effect of gravity is *relative acceleration* of nearby particles.

Challenge 961

It turns out the the tensor R describes precisely this relative acceleration, i.e. what we called the *tidal effects* earlier on. Obviously, the relative acceleration \mathbf{b} increases with the

* This is a short section for the more curious; it can be skipped at first reading.

** Bernhard Riemann (1826, Breselenz–1866, Selasca), important German mathematician.

*** Above, we showed that space-time is curved by noting changes in clock rates, in meter bar lengths, and in light propagation. Such experiments most easily provide the metric g . We know that space-time is described by a four-dimensional manifold \mathbf{M} with a metric g_{ab} which locally, at each space-time point, is a Minkowski metric with all its properties. Such a manifold is called a *riemannian manifold*. Only such a metric allows to define a local inertial system, i.e. a local Minkowski space-time at every space-time point. In particular, one has

$$g_{ab} = 1/g^{ab} \quad \text{and} \quad g_a^b = g^a_b = \delta_b^a \quad . \quad (267)$$

How are curvature and metric related? The solution usually occupies a large number of pages in relativity books; just for information, the relation is

$$R^a_{bcd} = \frac{\partial \Gamma^a_{bd}}{\partial x^c} - \frac{\partial \Gamma^a_{bc}}{\partial x^d} + \Gamma^a_{ec} \Gamma^e_{bd} - \Gamma^a_{fd} \Gamma^f_{bc} \quad . \quad (268)$$

The curvature tensor is built from the second derivatives of the metric. On the other hand, one can also determine the metric if the curvature is known, using

$$g = \dots R \dots \quad (269)$$

In other words, either the Riemann tensor R or the metric g specify the whole situation of a space-time.

Challenge 978 separation \mathbf{d} and the square (why?) of the speed \mathbf{u} of the two particles. Therefore one can also define R as a (generalized) proportionality factor among these quantities:

$$\mathbf{b} = R \mathbf{u} \mathbf{u} \mathbf{d} \quad \text{or, more clearly} \quad b^a = R^a{}_{bcd} u^b u^c d^d \quad . \quad (270)$$

The components of the Riemann curvature tensor have the dimension of an inverse square length. Since it contains all information about intrinsic curvature, one follows that if R vanishes in a region, space-time in that region is flat. This connection is easily deduced from this second definition.*

Challenge 995

A final way to define the tensor R is the following. For a free falling observer, the metric g_{ab} is given by the metric η_{ab} from special relativity. In its neighbourhood, one has

$$\begin{aligned} g_{ab} &= \eta_{ab} + \frac{1}{3} R_{abcd} x^c x^d + O(x^3) \\ &= \frac{1}{2} (\partial_c \partial_d g_{ab}) x^c x^d + O(x^3) \quad . \end{aligned} \quad (272)$$

The curvature tensor R is a large beast; it has $4^4 = 256$ components at each point of space-time; however, its symmetry properties reduce them to twenty independent numbers.** The actual number of importance in physical problems is still smaller, namely only ten. These are the components of the Ricci tensor, which can be defined with help of the Riemann tensor by contraction, i.e. by setting

$$R_{bc} = R^a{}_{bac} \quad . \quad (275)$$

Its components, like those of the Riemann tensor, are inverse square lengths.

* This second definition is also called the definition through *geodesic deviation*. It is of course not evident that it coincides with the first. For an explicit proof, see the literature. There is also a third way to picture the tensor R , a more mathematical one, namely the original way Riemann introduced it. If one parallel transports a vector \mathbf{w} around a parallelogram formed by two vectors \mathbf{u} and \mathbf{v} , each of length ϵ , the vector \mathbf{w} is changed to $\mathbf{w} + \delta\mathbf{w}$. One then has

$$\delta\mathbf{w} = -\epsilon^2 R \mathbf{u} \mathbf{v} \mathbf{w} + \text{higher order terms} \quad . \quad (271)$$

See page 114 More about the geodesic deviation can be found out by studying the behaviour of the famous south-pointing carriage. This device, common in China before the compass was discovered, only works if the world is flat. Indeed, on a curved surface, after following a large closed path, it will show a different direction than at the start of the trip. Can you explain why?

Challenge 1012

** The second definition indeed shows that the Riemann tensor is symmetric in certain indices and antisymmetric in others:

Challenge 1029

$$R_{abcd} = R_{cdab} \quad , \quad R_{abcd} = -R_{bacd} = -R_{abdc} \quad (273)$$

which also imply that many components vanish. Of importance is also the relation

$$R_{abcd} + R_{adbc} + R_{acdb} = 0 \quad . \quad (274)$$

Note that the order of the indices depends on the book one uses, and is not standardized. The list of invariants which can be constructed from R is long. We mention that $\frac{1}{2} \epsilon^{abcd} R_{cd}{}^{ef} R_{abef}$, namely the product $*R R$ of the Riemann tensor with its dual, is the invariant characterizing the Thirring-Lense effect.

9. Why can we see the stars? – Motion in the universe

Zwei Dinge erfüllen das Gemüt mit immer neuer und zunehmender Bewunderung und Ehrfurcht, je öfter und anhaltender sich das Nachdenken damit beschäftigt: der bestimmte Himmel über mir und das moralische Gesetz in mir.*

Immanuel Kant (1724–1804)

Ref. 66

On clear nights, between two and five thousand stars are visible with the naked eye. Several hundreds of them have names. Indeed, in all parts of the world, the stars and the constellations they form are seen as memories of ancient events, and stories are told about them.**

But the simple fact that we can *see* the stars is the basis for a story much more fantastic than all myths. It touches almost all aspects of modern physics.

Which stars do we see at all?

The stars we see on a clear night are mainly the brightest of our nearest neighbours in the surrounding region of the milky way. They lie at distances between four and a few thousand light years from us. Roughly speaking, in our environment there is a star about every 400 cubic light years.

In fact almost all visible stars are from our own galaxy. The only extragalactic object *constantly* visible to the naked eye in the northern hemisphere is the so-called Andromeda nebula, which in fact is a whole galaxy like our own, as Immanuel Kant already had conjectured in 1755. Several extragalactic objects are visible with the naked eye in the southern hemisphere: the Tarantula Nebula, and the large and the small Magellanic clouds, which are neighbour galaxies to our own. Other, temporary exceptions are the rare *novae*, exploding stars which can be seen also if they appear in nearby galaxies, or the still rarer *supernovae*, which can often be seen even in faraway galaxies.

In fact, the visible stars are special also in other respects. For example, telescopes show that about half of them are in fact double; they consist of two stars circling around each other, as in the case of *Sirius*. Measuring the orbits they follow around each other allows to determine their masses. Can you explain how?

Challenge 1046



Photograph still missing

Figure 126 How our galaxy looks in the infrared

Is the universe different from our milky way? Yes, it is. There are several arguments. First of all, our galaxy – that is just the Greek original of the term ‘milky way’ – is *flattened*, due to its rotation. If the galaxy rotates, there must be other masses which determine the background with respect to which this rotation takes place. In fact, there is a huge number of other galaxies – about 10^{11} – in the universe, a discovery dating only from the 20th century.

* Two things fill the mind with ever new and increasing admiration and awe, the more often and persistently thought considers them: the starry sky above me and the moral law inside me.

** About the myths around the stars and the constellations, see e.g. the text by G. FASCHING, *Sternbilder und ihre Mythen*, Springer Verlag, 1993. There are also the beautiful www.astro.wisc.edu/~dolan/constellations/constellations.html and www.astro.uiuc.edu/~kaler/sow/sow.html web sites.

Why did this happen so late? Well, people had the same difficulty as when the the shape of the earth had to be determined. One had to understand that the galaxy is not only a milky strip seen in clear nights, but an actual physical system, made of about 10^{11} stars gravitating around each other.* As in the case of the earth, the galaxy was found to have a three-dimensional *shape*; it is shown in Figure 126. Our galaxy is a flat and circular structure, with a diameter of 100 000 light years; in the centre, it has a spherical bulge. As said before, rotates once in about 200 to 250 million years. Can you guess how this is measured? The rotation quite is slow: since the sun exists, it made only about 20 to 25 full turns around the centre.

Challenge 1063

It is even possible to measure the *mass* of our galaxy. The trick is to use a binary pulsar on the outskirts of the galaxy. If one observes it for many years, one can deduce its acceleration around the galaxy centre. The pulsar reacts with a frequency shift which can be measured on earth. However, one needs many decades of observations, and one has to eliminate many spurious effects. Nevertheless, such measurements are ongoing.

Ref. 68

What do we see at night?

Astrophysics leads to a strange conclusion about matter, quite different from the what one is used to think in classical physics. *The matter observed in the sky is found in clouds.* *Clouds* are systems in which the matter density diminishes with distance from the centre, with no clear border, and with no clear size. It turns out that all astrophysical objects are best described by clouds.

The earth is a cloud, if one sees its atmosphere and its magnetosphere as part of it. The sun is a cloud. It is a gas ball anyway, but is even more a cloud if one takes into consideration its protuberances, its heliosphere, the solar wind it generates, and its magnetosphere. The solar system is a cloud, if one takes into consideration its comet cloud, its asteroid belt, and its local interstellar gas cloud. The galaxy is a cloud, if one remembers its matter distribution and cloud of the cosmic radiation it is surrounded with. In fact, even people can be seen as clouds, as every person is surrounded by gases, little dust particles from its skin, vapour, etc.

A second aspect is that in the universe, *almost all of the clouds are plasma clouds.* A *plasma* is an ionized gas, such as fire, lightning, the inside of neon tubes, the sun etc. At least 99.9% of all matter in the universe is in the form of plasmas. Only an exceptionally small percentage exists in solid or liquid form, such as toasters, subways, or their users.

A third aspect is about the shape of the observed components. All clouds seen in the universe are rotating. Most are therefore flattened. In addition, many clouds emit something along the rotation axis. This has been observed for stars, for pulsars, for our planetary system, for galaxies, for quasars, and for many other systems.

* The milky way, or *galaxy* in Greek, was said to have originated when Zeus, the main Greek god, tried to let his son Heracles feed at Hera's breast in order to make him immortal; the young Heracles, in a sign showing his future strength, sucked so forcefully that the milk splashed all over the sky.

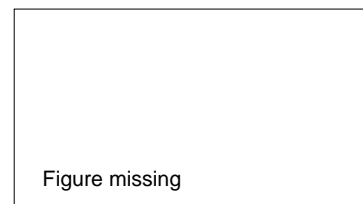

Figure 127 A few galaxies: the Andromeda nebula M31, a spiral galaxy, the elliptical galaxy NGC 205, and the colliding galaxies M51, also known as NGC 5194

Some of the information collected by modern astronomy and astrophysics about the various clouds in the universe is shown in the following table. * Ref. 54

Table 26 Some observations about the universe

Aspect	main properties	value
Phenomena		
galaxy formation	observed by Hubble trigger event	several times unknown
galactic collisions	momentum star formation	$p \approx$
star formation	cloud collapse	
novae	new bright stars, later surrounded by bubble	$L > \dots$ $R \approx t \cdot c/100$
supernovae	new bright star, matter forms	$L > \dots$
gamma ray bursts	luminosity energy duration observed number	up to $3 \cdot 10^{47}$ W, almost equal to the whole visible universe ca. 10^{46} J ca. 0.015– 1000 s ca. 2 per day
hypernovae, optical bursts		
radio sources		
X-ray sources		
cosmic rays	energy	from 0 eV to 10^{22} eV
gravitational lensing	light bending	
comets	recurrence, evaporation	
meteorites	age	up to $4.6 \cdot 10^9$ a
Observed components		
intergalactic space	mass density	...
quasars	redshift luminosity	up to 5.8 ..., about the same as one galaxy
galaxy superclusters	number	ca. 10^8 inside horizon
our own local supercluster		with about 4000 galaxies
galaxy groups		100 Zm, with a dozen up to 1000 galaxies
our local group		with 30 galaxies
galaxies	size number containing	0.5 to 2 Zm ca. 10^{11} inside horizon 10 to 400 globular clusters
our galaxy	containing diameter mass containing	typically 10^{11} stars 1.0(0.1) Zm 10^{42} kg or $5 \cdot 10^{11}$ solar masses Ref. 67 100 globular clusters each with 1 million stars

* Many details about the universe can be found in the beautiful text by W.J. KAUFMANN & R.A. FRIEDMAN, *Universe*, fifth edition, W.H. Freeman & Co., 1999. Recent discoveries are best followed on the <http://hubble.nasa.gov> web site.

Aspect	main properties	value
nebulae, clouds	speed	600 km/s towards Hydra-Centaurus
our local interstellar cloud	composition	
	size	20 light years
star systems	composition	atomic hydrogen at 7500 K
	types	orbiting double stars, star plus dwarfs, possibly a few planetary systems
our solar system	size	2 light years (Oort cloud)
our solar system stars	speed	370 km/s from Aquarius towards Leo
giants and supergiants	large size	up to ...
brown dwarfs	low temperature	below 2800 K Ref. 69
L dwarfs	low temperature	
T dwarfs	low temperature	
white dwarfs	high temperature	
neutron stars	nuclear mass density, size about 10 km	
pulsars	radio emission	
magnetars	high magnetic fields	
black holes	horizon radius	$r = 2GM/c^2$
General properties		
cosmic horizon	distance	ca. 10^{26} m
expansion	Hubble's constant	between $59 \text{ km s}^{-1} \text{ Mpc}^{-1}$ and $70 \text{ km s}^{-1} \text{ Mpc}^{-1}$, or ca. $2 \cdot 10^{-18} / \text{s}$
vacuum energy density	finite	0.5 nJ/m^3
large size shape	space curvature	almost vanishing
large size shape	topology	simple in our galactic environment, unknown at large scales
dimensions	number	3 for space, 1 for time, at low and moderate energies
mass-energy	density	2 to $11 \cdot 10^{-27} \text{ kg/m}^3$ or 1 to 6 hydrogen atoms per cubic metre
baryons	density	one sixth of the previous
other	density	five sixths unknown
photons	number density	4 to $5 \cdot 10^8 / \text{m}^3$ $= 1.7 \text{ to } 2.1 \cdot 10^{-31} \text{ kg/m}^3$
neutrinos	number density	not measured
average temperature	photons	2.7 K
	matter	ca. 0 K
	neutrinos	not measured, 2 K predicted
original inhomogeneity	amplitude of radiation anisotropy	
	amplitude of matter clustering	

Since we are speaking of what we see in the sky, we need to clarify a general issue.

What is the universe?

I'm astounded by people who want to 'know' the universe
when it's hard enough to find your way around Chinatown.
Woody Allen

The universe, as the name says, is what turns around us at night. For a physicist, at least three definitions are possible for the term 'universe'.

- The (*visible*) universe is the totality of all observable mass and energy.
- The (*believer*) universe is the totality of all mass and energy, *including* any parts of them which are not visible. All books of general relativity state that there definitely exists matter or energy beyond the observation boundaries. We explain the origin of this idea below.
- The (*total*) universe is the sum of matter, energy *as well as* space-time itself.

These definitions are often mixed up in physical and philosophical discussions. There is *no* generally accepted consensus, so one has to be careful. In this walk, when we use the term 'universe', we imply the *last* definition only. We will discover repeatedly that without clear distinction between the definitions the complete mountain ascent of motion mountain becomes impossible.

Note that the 'size' of the visible universe, or better, the distance to its horizon, is a quantity which *can* be imagined. If one took all the iron from the earth's core and made it into a wire as long as this size, how thick would it be? The answer might surprise you. Also the content of the universe is finite. There are about as many visible *galaxies* in the universe as there are grains in a cubic metre of sand. To expand on the comparison, can you deduce how much space one needs to store the flour one would get if ever little speck represented one star?

Challenge 1080

Challenge 1097

The colour and the motion of the stars

Verily, at first chaos came to be ...
Theogony, v. 120, Hesiod*

Obviously, the universe is full of motion. To get to know the universe a bit, it is useful to measure the speed and position of as many objects in it as possible. In the twentieth century, a large number of such observations have been performed on stars and galaxies. (Can you imagine how distance and velocity are determined?) This wealth of data can be summed up in two points.

Challenge 1114

First of all, on large scales, i.e. averaged over about ten million light years, the matter density in the universe is *homogeneous* and *isotropic*. Obviously, at smaller scales inhomogeneities exist, such as galaxies or cheese cakes. Our galaxy for example is neither isotropic nor homogeneous. But at large scales the differences average out. This large scale homogeneity of matter position is often called the *cosmological principle*.

Ref. 58

The second point about the universe is even more important. In the 1920s, Wirtz and Lundmark showed that on the whole, galaxies move away from the earth, and the more, the more they were distant. There are a few exceptions for nearby galaxies, such as the

* The Theogony, attributed to the probably mythical Hesiodos, was finalized around 700 BCE. It can be read in English and Greek on the <http://perseus.csad.ox.ac.uk/cgi-bin/ptext?lookup=Hes.+Th.+5> web site.

Andromeda nebula itself; but in general, the speed of flight v of an object increases with distance d . In 1929, the American astronomer Edwin Hubble* published the first measurement of the relation between speed and distance. Despite his use of incorrect length scales he found a relation

$$v = H d \quad , \quad (276)$$

where the proportionality constant H , so-called *Hubble constant*, is known today to have a value between $59 \text{ km s}^{-1} \text{ Mpc}^{-1}$ and $70 \text{ km s}^{-1} \text{ Mpc}^{-1}$. (Hubble's own value was far outside this range.) For example, a star at a distance of 2 Mparsec is moving away from earth with a speed between 118 km/s and 140 km/s, and proportionally more for stars further away.

Challenge 10

In fact, the discovery by Wirtz and Lundwerk implies that every galaxy moves away from all the others. (Why?) In other words, the matter in the universe is *expanding*. The scale of this expansion and the enormous dimensions involved are amazing. The motion of all the thousand millions galaxy groups in the sky are described by the single equation (276)! Of course, some deviations are observed for nearby galaxies, as mentioned above, and for far away galaxies, as we will see.

In addition, the cosmological principle and the expansion imply that the universe cannot be older than that time when it was of vanishing size; the universe thus has a *finite age*. Including the evolution equations, as explained in more detail below, the Hubble constant points to an age value of around twelve thousand million years, with an error of about a sixth of this value. That also means that the universe has a *horizon*, i.e. a finite distance beyond which no signal reaches us.

Challenge 27

Ref. 55

Since the universe is expanding, in the past it has been much smaller and thus much denser than it is now. It turns out that it also has been hotter. George Gamow** predicted in 1948 that since hot objects radiate light, the sky cannot be completely black at night, but must be filled with black body radiation emitted during the times it was in heat. That radiation, called the *background radiation*, must have cooled down due to the expansion of the universe. (Can you confirm this?) Despite various similar predictions by other authors, in one of the most famous cases of missed scientific communication, the radiation was found only much later, by two researchers completely unaware of all this work. A famous paper in 1964 by Doroshkevich and Novikov had even stated that the antenna used by the (unaware) later discoverers was the best device to search for the radiation! In any case, only in 1965, Arno Penzias and Robert Wilson discovered the radiation, in one of the most beautiful discoveries of physics, for which both later received the Nobel prize for physics. The radiation turns out to be described by the blackbody radiation for a body with a temperature of 2.7 K to the precision of about 1 part in 10^4 .

Ref. 56

Ref. 57

But apart from expansion and cooling, the past twelve thousand million years also produced a few other memorable events.

* Edwin Powell Hubble (1889–1953), important US-American astronomer. After being athlete and taking a law degree, he returned to his child passion of the stars; he finally proved Immanuel Kant's 1755 conjecture that the Andromeda nebula was a galaxy like our own. He thus showed that the milky way is only a tiny part of the universe.

** George Gamow (1904, Odessa–1968), Russian-American physicist; he explained alpha decay as a tunnel effect and predicted the microwave background. He wrote the first successful popular science texts, such as *1, 2, 3, infinity* and the *Mr. Thompkins* series, which later were imitated by many others.

Do stars shine every night?

Do you see the stars shine?
I am the only in the world one who knows why.
Eddington, in conversation.

Stars seems to be there for ever. In fact, every now and then a new star appears in the sky: a *nova*. Especially bright novae are called *supernovae*. Novae and similar phenomena remind us that stars usually live much longer than humans, but that like them, they are born and die.

It turns out that one can follow the age of a star in the so-called *Hertzsprung-Russel diagram*. The diagram, found in every book on astronomy, is a beautiful example of a standard method used by astrophysicists: they make statistics over many examples of a type of object, and then can deduce their life cycle, even though it is much longer than the time a human can observe the sky. For example, it is possible, by clever use of the diagram, to estimate the age of stellar clusters, and thus provide a minimum age of the universe. The result is around twelve thousand million years.

One conclusion is essential: since stars shine, they also *die*. In other words, stars can be seen if they are born but not yet dead at the moment of light emission. That also leads to restrictions on their visibility, especially for high red shifts. Indeed, the objects one observes at large distances, such as quasars, are not stars, but much more massive and bright systems. These issues are still being studied by astrophysicists.

On the other hand, since the stars shine, they were also *formed* somehow. The fascinating details of these investigations are part of astrophysics and will not be explored here.

But that is still not the full answer to the question. Why do stars shine at all? The shine because they are hot. They are hot because of nuclear reactions in their interior. We will discuss these processes in more detail in the chapter on the nucleus.

See page 624

A short history of the universe

The soul is a spark of the substance of the stars.
Heraclitos of Ephesos (ca. 540–ca. 480 BCE)

Ref. 53

The adventures the universe has experienced, or better, the matter and radiation inside it, are summarized in Table 27.* The steps not yet discussed will be studied in quantum theory. The history table has applications no physicist would have imagined. The sequence is so beautiful and impressive that nowadays it is used in certain psychotherapies to point out to people the story behind their existence and to remind them of their own worth. Enjoy.

Table 27 A short history of the universe

Time from now ^a	Time from big Event bang ^b	Temperature
$\approx 13 \cdot 10^9$ a	$\approx t_{\text{Pl}}$ ^b	Time, space, matter, and initial conditions make no sense 10^{32} K $\approx T_{\text{Pl}}$

* On the remote history of the universe, see the excellent text by G. BÖRNER, *The early universe – facts & fiction*, 3rd edition, Springer Verlag, 1993. For an excellent popular text, see M. LONGAIR, *Our evolving universe*, Cambridge University Press, 1996.

Time from now ^a	Time from big bang ^b	Event	Temperature
$13 \cdot 10^9$ a	ca. $800 t_{\text{Pl}}$ $\approx 10^{-42}$ s	Distinction of space-time and matter, initial conditions make sense	10^{30} K
	10^{-35} s to 10^{-32} s	Inflation & GUT epoch starts; strong and electroweak interactions diverge	$5 \cdot 10^{26}$ K
	10^{-12} s	Antiquarks annihilate; electromagnetic and weak interaction separate	10^{15} K
	$2 \cdot 10^{-6}$ s	Quarks get confined into hadrons; universe is a plasma Positrons annihilate	10^{13} K
	0.3 s	Universe becomes transparent for neutrinos	10^{10} K
	a few seconds	Nucleosynthesis: D, ^4He , ^3He and ^7Li <i>nuclei</i> form; radiation still dominates	10^9 K
	2500 a	Matter domination starts; density perturbations magnify	75 000 K
$z = 1100$	300 000 a	Recombination: during these latter stages of the big bang, H, He and Li <i>atoms</i> form, and the universe becomes ‘transparent’ for light, as matter and radiation decouple, i.e. as they acquire different temperatures; the ‘night’ sky starts to get darker and darker Sky is almost black except for blackbody radiation	3000 K $T_{\gamma} = T_0(1+z)$
$z = 10 - 30$		Galaxy formation	
$z = 5.8$		Oldest object seen so far	
$z = 5$		Galaxy clusters form	
$z = 3$	10^6 a	First generation of stars (population II) is formed, hydrogen fusion starts; helium fusion produces carbon, silicon, oxygen	
	$2 \cdot 10^9$ a	First stars explode as supernovae ^c ; iron is produced	
$z = 1$	$3 \cdot 10^9$ a	Second generation of stars (population I) appears, and subsequent supernova explosions of the aging stars form the trace elements (Fe, Se, ..) we are made of and blow them into the galaxy	
$4.7 \cdot 10^9$ a		Primitive cloud, made from such explosion remnants, collapses; sun forms	
$4.6 \cdot 10^9$ a		Earth and the other planets form	
$4.3 \cdot 10^9$ a		Craters form on the planets	
$4.0 \cdot 10^9$ a		Moon forms from material ejected during the collision of a large asteroid with the earth	
$4.0 \cdot 10^9$ a		Archeozoic starts: Earth’s crust solidifies, oldest minerals water condenses	
$3 \cdot 10^9$ a		Unicellular (microscopic) life appears	
$2.6 \cdot 10^9$ a		Protozoic starts: atmosphere becomes rich in oxygen	
$1 \cdot 10^9$ a		Macroscopic life appears	
$580 \cdot 10^6$ a		Palaeozoic starts, after a gigantic ice age; animals appear; oldest fossils	
$400 \cdot 10^6$ a		Land plants appear	
$370 \cdot 10^6$ a		Wooden trees appear	

Time from now ^a	Time from big bang ^b	Event	Temperature
220 · 10 ⁶ a		Mesozoic starts: mammals appear, insects are exterminated	
150 · 10 ⁶ a		Continent Pangaea splits into Laurasia and Gondwana The star cluster of the Pleiades forms	
ca. 150 · 10 ⁶ a			
150 · 10 ⁶ a		Birds appear	
135 to		Golden time of dinosaurs	
65 · 10 ⁶ a			
100 · 10 ⁶ a		Start of formation of Alps, Andes and Rocky mountains	
65 · 10 ⁶ a		Cenozoic starts: Dinosaurs become extinct due to a comet or asteroid hitting the earth in the Yucatan, primates appear	
50 · 10 ⁶ a		Large mammals appear	
6 – 8 · 10 ⁶ a		Hominids appears	
5 · 10 ⁶ a		Homo appears	
500 000 a		Formation of youngest stars in galaxy	
300 000 a		Homo sapiens appears	
100 000 a		Beginning of last ice age	
90 000 a		Homo sapiens sapiens appears	
20– to		End of last ice age	
11 000 a			
6 000 a		First written texts	
2 500 a		Physics starts	
500 a		Coffee usage spreads, modern physics starts	
200 a		Electricity usage begins	
100 a		Einstein publishes	
10 – 120 a		You were an unicellular being	
present	ca. 13 · 10 ⁹ a	You are reading this	$T_\gamma = 2.73 \text{ K},$ $T_V \approx 1.6 \text{ K},$ $T_b \approx 0 \text{ K}$
future		You enjoy life; for more details and reasons, see page 411	

a. The time coordinate used here is the one given by the coordinate system defined by the microwave background radiation, as explained on page 293.

b. This quantity is not exactly defined since the big bang is not a space-time event. More on the issue later, on page 701.

c. The history of the atoms shows that we are made from the leftovers of a supernova. We truly are made of *stardust*.

Despite its length and its interest, this table has its limitations. For example, what happened elsewhere in the last few thousand million years? There is still a story to be written of which next to nothing is known. For strange reasons, investigations have been rather earth-centred.

Researching astrophysics is directed at discovering and understanding all phenomena observed in the skies. Here we skip most of this fascinating topic, since as usual, we focus on

motion. Interestingly, general relativity allows to explain many of the general observations about motion in the universe.

The history of of space-time

Challenge 44 A number of rabbits run away from a central point in various directions, all with the same speed. While running, one rabbit turns its head, and makes a startling observation. What does it see?

The data showing that the universe is sprinkled with stars all over leads to a simple conclusion: the universe cannot be static. Gravity always changes the distances between bodies; the only exceptions are circular orbits. Gravity also changes the *average* distances between bodies; gravity always tries to collapse clouds. The biggest cloud of all, the one formed by the matter in the universe, must therefore either be collapsing, or still be in expansion.

Ref. 59 The first to dare to take this conclusion was Aleksander Friedmann.* In 1922 he deduced the detailed evolution of the universe with homogeneous, isotropic mass distribution in the know standard fashion. For a universe which is homogeneous and isotropic for every point,

Challenge 61 the line element is given by

$$ds^2 = c^2 dt^2 - a^2(t)(dx^2 + dy^2 + dz^2) \quad (277)$$

and matter is described by a density ρ_M and a pressure p_M . Inserting all this into the field equations, one gets two equations

$$\left(\frac{\dot{a}}{a}\right)^2 + \frac{k}{a^2} = \frac{8\pi G}{3}\rho_M + \frac{\Lambda}{3} \quad \text{and} \quad (278)$$

$$\ddot{a} = -\frac{4\pi G}{3}(\rho_M + 3p_M)a + \frac{\Lambda}{3}a \quad (279)$$

which imply

$$\dot{\rho}_M = -3\frac{\dot{a}}{a}(\rho_M + p_M) \quad (280)$$

At the present time t_0 , the pressure of matter is negligible. In this case, the expression $\rho_M a^3$ is constant in time.

Challenge 78 Before we discuss the equation, first a few points of vocabulary. It is customary to relate all mass densities to the so-called *critical mass density* ρ_c given by

$$\rho_c = \frac{3H_0^2}{8\pi G} \approx 8 \pm 2 \cdot 10^{-27} \text{ kg/m}^3 \quad (281)$$

corresponding to about 8, give or take 2, hydrogen atoms per cubic metre. On earth, one would call this value an extremely good *vacuum*. Such are the differences between everyday

* Aleksander Aleksandrowitsch Friedmann (1888–1925), Russian physicist who predicted the expansion of the universe. Due to his early death of typhus, his work remained almost unknown until Georges A. Lemaître (1894–1966), Belgian priest and cosmologist, took it up and expanded it in 1927, focussing, as his job required, on solutions with an initial singularity. Lemaître was one of the propagators of the (erroneous) idea that the big bang was an ‘event’ of ‘creation’ and convinced his whole organisation about it. The Friedman-Lemaître solutions are often erroneously called after two other physicists, who studied them again much later, in 1935 and 1936, namely H.P. Robertson and A.G. Walker.

See page 298, 299

life and the universe as a whole. In any case, the critical density characterizes a matter distribution leading to an evolution of the universe just between neverending expansion and collapse. In fact, this density is the critical one, leading to a so-called *marginal* evolution, only in the case of *vanishing* cosmological constant. Despite this restriction, the term is now used for this expression in all other cases as well. One thus speaks of dimensionless mass densities Ω_M defined as

$$\Omega_M = \rho_o / \rho_c \quad . \quad (282)$$

The cosmological constant can also be related to this critical density by setting

$$\Omega_\Lambda = \frac{\rho_\Lambda}{\rho_c} = \frac{\Lambda c^2}{8\pi G \rho_c} = \frac{\Lambda c^2}{3H_o^2} \quad . \quad (283)$$

A third dimensionless parameter Ω_K describes the curvature of space. It is defined as

$$\Omega_K = \frac{-k}{R_o^2 H_o^2} \quad (284)$$

and its sign is opposite to the one of the curvature; Ω_K vanishes for vanishing curvature. Note that a positively curved universe is necessarily closed and of finite volume. A flat or negatively curved universe can be open, i.e. of infinite volume, but does not need to be so. It could be simply or multiply connected. In these cases the topology is not completely fixed by the curvature.

The present time Hubble parameter is defined by $H_o = \dot{a}_o / a_o$. From equation (278) one then gets:

Challenge 95

$$\Omega_M + \Omega_\Lambda + \Omega_K = 1 \quad . \quad (285)$$

In the past, when data was lacking, physicists were divided into two camps: the *claustrophobics* believing that $\Omega_K > 0$ and the *agoraphobics* who believe that $\Omega_K < 0$. More details about the measured values of these parameters will be given shortly. The diagram of Figure 128 shows the most interesting ranges of parameters together with the corresponding behaviour of the universe.

For the Hubble parameter, the most modern measurements give a value of

$$65 \pm 5 \text{ km/sMpc} \approx 2 \cdot 10^{-18} / \text{s} \quad (286)$$

which correspond to an age of the universe of 13.5 ± 1.5 thousand million years. In other words, the age deduced from the history of space-time corresponds with the age, given above, deduced

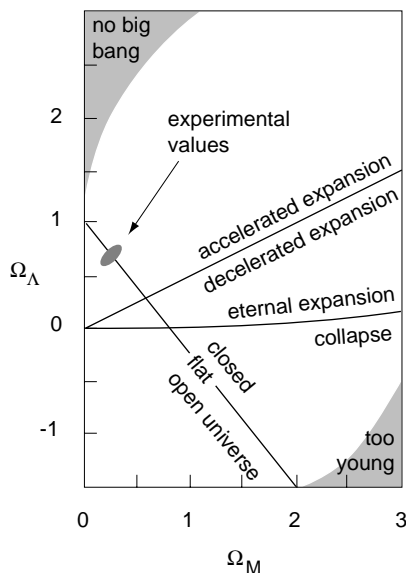

Figure 128 The ranges for the Ω parameters and their consequences

from the history of stars.

To get a feeling of how the universe evolves, it is customary to use the so-called *deceleration parameter* q_0 . It is defined as

$$q_0 = -\frac{\ddot{a}_0}{a_0 H_0^2} = \frac{1}{2} \Omega_M - \Omega_\Lambda \tag{287}$$

The parameter q_0 is positive if the expansion is slowing down, and negative if the expansion is accelerating. These possibilities are also shown in the diagram.

An even clearer way to picture the expansion of the universe for vanishing pressure is to rewrite equation (278) using $\tau = t H_0$ and $x(\tau) = a(t)/a(t_0)$, yielding

$$\left(\frac{dx}{d\tau}\right)^2 + U(x) = \Omega_K$$

with $U(x) = -\Omega_\Lambda x - \Omega_M x^2$ (288)

This looks like the evolution equation for the motion of a particle with mass 1, with total energy Ω_K in a potential $U(x)$. The resulting evolutions are easily deduced.

For vanishing Ω_Λ , the universe either expands for ever, or recollapses, depending on the value of the mass-energy density,

For non-vanishing (positive) Ω_Λ , the potential has exactly one maximum; if the particle has enough energy to get over the maximum, it will accelerate continuously. That is the situation the universe seems to be in today.

For a certain time range, the result is shown in Figure 129. There are two points to be noted: the set of possible curves is described by *two* parameters, not one. In addition, lines cannot be drawn down to the origin of the diagram. There are two main reasons: we do not know the behaviour of matter at very high energy yet, and we do not know the behaviour of space-time at very high energy. We return to this important issue later on.

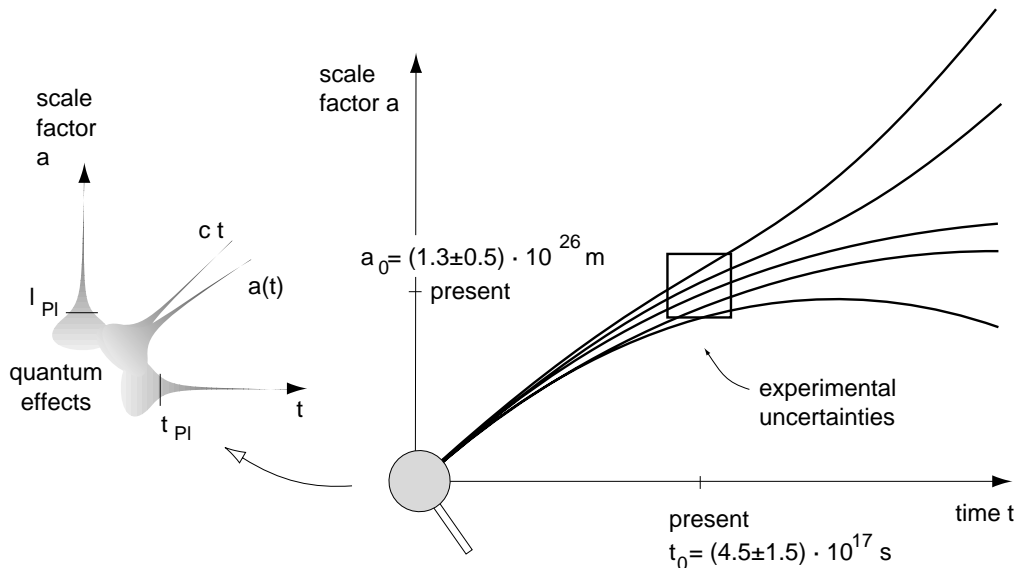

Figure 129 The evolution of the universe’s scale R for different values of its mass density

The main result of Friedmann’s work was that a homogenous and isotropic universe is *not static*: it either expands or contracts. In either case, it has a *finite age*. This profound result took many years to spread around the cosmology community; even Einstein took a long time to get accustomed to it.

Note that due to its isotropic expansion, in the universe there is a preferred reference frame: the frame defined by average matter. The time measured in that frame is the time listed in Table 27 and the one meant when one talks about the *age* of the universe.

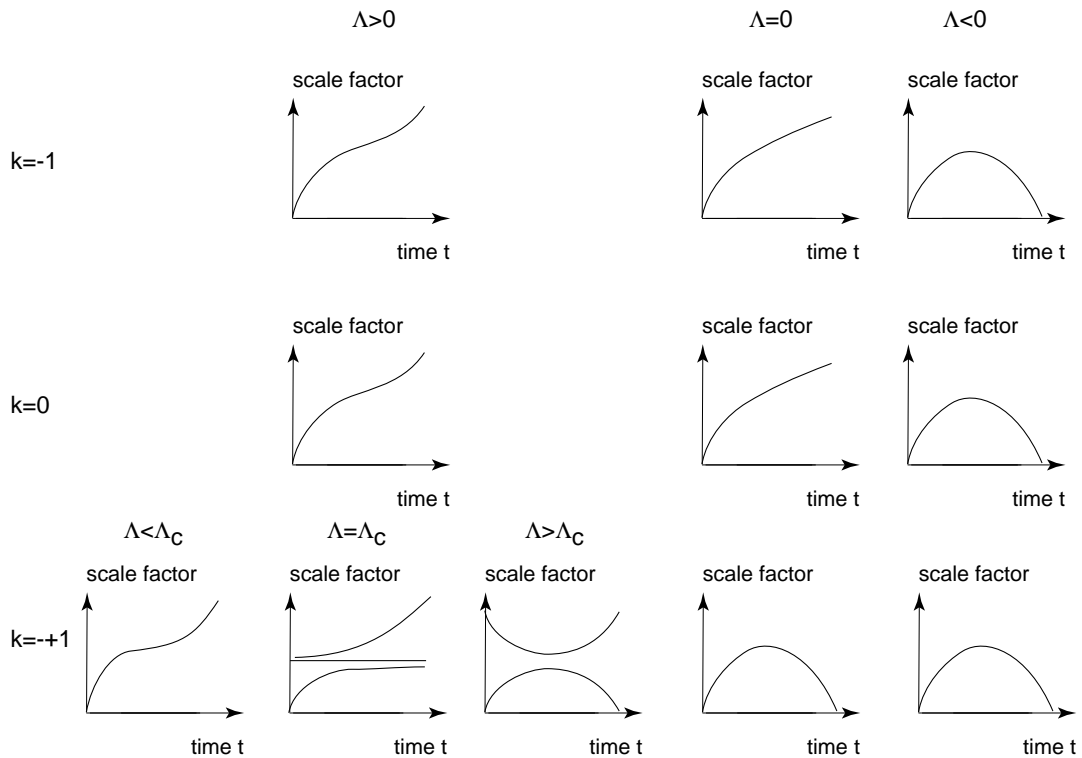

Figure 130 The long term evolution of the universe’s scale a for various parameter combinations

An overview of the possibilities for the long time evolution is given in Figure 130. The evolution can have various outcomes. In the early twentieth century, people decided among them by personal preference. Albert Einstein first preferred the solution $k = 1$ and $\Lambda = a^{-2} = 4\pi G\rho_M$. It is the unstable solution found when $x(\tau)$ remains at the top of the potential $U(x)$.

De Sitter had found, much to Einstein’s personal dismay, that an empty universe with $\rho_M = p_M = 0$ and $k = 1$ is also possible. This type of universe expands for large times.

Challenge 112

Lemaître had found expanding universes for positive mass, and his results were also contested by Einstein in the beginning. When later the first measurements confirmed the calculations, massive and expanding universes became popular and the standard story in textbooks. However, in a sort of collective blindness that lasted from around 1950 to 1990,

almost everybody believed that $\Lambda = 0$.^{*} Only towards the end of the twentieth century experimental progress allowed to make statements free of personal beliefs, as we will find out shortly. But first of all we settle an old issue.

Why is the sky dark at night?

First of all, the sky is not black at night. It has the same colour as during the day, as any long exposure photograph shows. But that colour, like to colour of the sky during the day, is not due to the temperature of the sky, but to the light from the stars. If one looks for temperature radiation, one does find some. Measurements show that the sky is not completely cold at night. It is filled with radiation of around 200 GHz; more precise measurements show that the radiation corresponds to the thermal emission of a body of 2.73 K. This *background radiation* is the thermal radiation left over from the big bang.

Ref. 71 The universe is indeed colder than the stars. But why is this so? If the universe were homogenous on large scales and infinitely large, it would have an infinite number of stars. Given any direction one would look at, one would hit the surface of a star. The night sky would be as bright as the surface of the sun! Are you able to convince your grandmother about this?

Challenge 146

In other words, we would effectively live inside an oven with a temperature of the average star, namely about 6000 K, thus making it effectively impossible to enjoy ice cream. This paradox was most clearly formulated in 1823 by the astronomer Wilhelm Olbers.^{**} Today we know that even if all matter in the universe were converted into radiation, the universe would still not be as bright as just calculated. Equivalently, the lifetime of stars is way too short to produce the oven brightness just mentioned. So something is wrong.

Ref. 72

In fact, two main effects have the power to avoid the contradiction with observations. First, since the universe is finite in age, far away stars are shining for less time, so that their share is smaller, and thus the average temperature of the sky is reduced.^{***}

Secondly, one could imagine that the radiation of far away stars is shifted to the red, and the volume the radiation must fill is increasing continuously, so that the average temperature of the sky is also reduced. One needs calculations to decide which effect is the greater one.

Ref. 73

This issue has been studied in great detail by Paul Wesson; he explains that the first effect is larger than the second by a factor of three. We may thus state correctly that the sky is dark at night *mostly* because the universe has a *finite* age. We can thus add that the sky would be brighter if the universe were not expanding.

Ref. 71

In addition, the darkness of the sky is possible only because the speed of light is *finite*. Can you confirm this?

Challenge 180

* In this case, one has the connection that for $\Omega_M \geq 1$, the age of the universe follows $t_0 \leq 2/(3H_0)$, where the limits correspond. For vanishing mass density one has $t_0 = 1/H_0$.

Challenge 129

** Heinrich Wilhelm Matthias Olbers (1758, Arbergen – 1840, Bremen), astronomer. He discovered two planetoids, Pallas and Vesta, and five comets; he developed the method to calculate parabolic orbits for comets which is still in use today. Olbers also actively supported F.W. Bessel in his career choice. The paradox is named after him, though others had made similar points before, such as the Swiss astronomer de Cheseaux in 1744 and Johannes Kepler in 1610.

*** Are you able to explain that the sky is not black because it is painted black or made of black chocolate? Or more generally, that the sky is not a made of or does not contain some dark and cold substance, as Olbers himself suggested, and as J. Herschel proved wrong in 1848?

Challenge 163

Finally, the darkness of the sky also tells us that the universe has a *large* age. Indeed, the 2.7 K background radiation is that cold, despite having been emitted at 3000 K, because it is red shifted due to the Doppler effect. Under reasonable assumptions, the temperature of this radiation changes with the scale factor of the universe as

Ref. 74

$$T \sim \frac{1}{R(t)} . \quad (289)$$

In a young universe, we would not be able to see the stars even if they existed.

Note that from the brightness of the sky at night, measured to be about $3 \cdot 10^{-13}$ times that of an average star like the sun, one can deduce something interesting: the density of stars in the universe must be much smaller than in our galaxy. The density of stars in the galaxy can be deduced by counting the stars we see at night. But the average star density in the galaxy would lead to much higher values for the night brightness if it were constant throughout the universe. One can thus deduce that the galaxy is much *smaller* than the universe simply by measuring the brightness of the night sky and by counting the stars in the sky! Can you make the explicit calculation?

Ref. 72

Challenge 197

In summary, the sky is black at night because space-time is of finite, but old age. As a side issue, here is a quiz: is there an Olbers' paradox also for gravitation?

Challenge 214

Is the universe open, closed or marginal?

- Doesn't the vastness of the universe make you feel small?

- I can feel small without any help from the universe.

Anonymous

Sometimes the history of the universe is summed up in two words: *bang!...crunch*. But will the universe indeed recollapse or will it expand for ever? The parameters deciding its fate are the mass density and cosmological constant, and so far, they point into a different direction.

The main news of the last decade of the twentieth century astrophysics are the experimental results allowing to determine all these parameters. Several methods are being used. The first method is obvious: determine speed and distance of distant stars. For large distances, this is difficult, since the stars get faint. But it has now become possible to search the sky for supernovae, the bright exploding stars, and to determine their distance through their brightness. This is presently being done with help of computerized searches of the sky, using the largest available telescopes.

Ref. 61

A second method is the measurement of the anisotropy of the cosmic microwave background. From the power spectrum as function of the angle one can deduce the curvature of space-time.

A third method is the determination of the mass density using the gravitational lensing effect for the light of distant quasars bent around galaxies or galaxy clusters.

See page 302

A fourth method is the determination of the mass density using galaxy clusters. All these measurements are expected to improve greatly in the years to come.

At present, these four completely independent sets of measurements provide the values

Ref. 60

$$(\Omega_M, \Omega_\Lambda, \Omega_K) \approx (0.3, 0.7, 0.0) \quad (290)$$

where the errors are of the order of 0.1 or less. The values imply that *the universe is spatially flat, its expansion is accelerating, and there will be no big crunch*. However, no definite statement on the topology is possible. We come back to this issue shortly.

See page 303

In particular, the data show that the density of matter, inclusive all dark matter, is only about one third of the critical value. * Twice that amount is given by the cosmological term. For the cosmological constant Λ one gets the value

$$\Lambda = \Omega_{\Lambda} \frac{3H_0^2}{c^2} \approx 10^{-52} / \text{m}^2 \quad (291)$$

This value has important implications for quantum theory, since it corresponds to a vacuum energy density

$$\rho_{\Lambda} c^2 = \frac{\Lambda c^4}{8\pi G} \approx 0.5 \text{ nJ/m}^3 \approx \frac{10^{-46} (\text{GeV})^4}{(\hbar c)^3} \quad (292)$$

But the cosmological term also implies a negative vacuum pressure $p_{\Lambda} = -\rho_{\Lambda} c^2$. Inserting this result into the relation for the potential of universal gravity deduced from relativity

See page 274

$$\Delta\phi = 4\pi G(\rho + 3p/c^2) \quad (293)$$

one gets

$$\Delta\phi = 4\pi G(\rho_M - 2\rho_{\Lambda}) \quad (294)$$

Challenge 231 one thus for the gravitational acceleration

$$a = \frac{GM}{r^2} - \frac{\Lambda}{3} c^2 r = \frac{GM}{r^2} - \Omega_{\Lambda} H_0^2 r \quad (295)$$

which shows that a *positive* vacuum energy indeed leads to a *repulsive* gravitational effect. Inserting the mentioned value for the cosmological constant Λ one finds that the repulsive effect is small even for the distance between the earth and the sun. In fact, the order of magnitude is so much smaller that one cannot hope for a direct experimental confirmation of this deviation from universal gravity at all. Probably astrophysical determinations will remain the only possible ones. A positive gravitational constant manifests itself through a positive component in the expansion rate, as we will see shortly.

Challenge 248

But the situation is puzzling. The origin of this cosmological constant is *not* explained by general relativity; this mystery will be solved only with help of quantum theory. In any case, the cosmological constant is the first local and quantum aspect of nature detected by astrophysical means.

Why is the universe transparent?

Could the universe be filled with water, which is transparent, as maintained by some popular books in order to explain rain? No. Even if it were filled with air, the total mass would never

Ref. 70

Challenge 265 have allowed the universe to reach the present size; it would have recollapsed much earlier and we would not exist.

The universe is thus transparent because it is mostly empty. But *why* is it so empty? First of all, in the times when the size of the universe was small, all antimatter annihilated with the corresponding amount of matter, and only a tiny fraction of matter, which was slightly more abundant, was left over. This 10^{-9} fraction is the matter we see now. As a consequence, the number of photons in the universe is 10^9 larger than that of electrons or quarks.

See page 625

If one remembers that the average density of the universe is 10^{-26} kg/m³ and that most of the matter is lumped by gravity in galaxies, one can imagine what an excellent vacuum lies in between. As a result, light can travel along large distances without hindrance.

In addition, 300 000 years after antimatter annihilation, all available nuclei and electrons recombined, forming atoms, and their aggregates, like stars and people. No free charges interacting with photons were lurking around any more, so that from that period onwards light could travel through space like it does today, being affected only when it hits some star or some dust particle.

But why is the vacuum transparent? That is a much deeper question and we reserve it for a later stage of our walk. Let us turn to a few other issues.

The big bang and its consequences

Learn to die.
Plato (427–347 BCE)

Above all, the big bang model, which is deduced from the colour of the stars and galaxies, states that about twelve thousand million years ago the whole universe was extremely small, a fact that gave the big bang its name. The expression ‘big bang’ was created in 1950 by Fred Hoyle, * who by the way never believed that it gives a correct description of the evolution of the universe. Since the past smallness cannot itself be checked, one needs to look for other, verifiable consequences. The central ones are the following:

Ref. 62

- all matter moves away from all other matter;
- there is about 25% helium in the universe;
- there is thermal background radiation of about 3 K;
- the maximal age for any system in the universe is around twelve thousand million years;
- there are background neutrinos with a temperature of about 2 K; **
- for nonvanishing cosmological constant, Newtonian gravity is slightly reduced.

All predictions, except the last two, are confirmed by observations. Technology probably will not allow to check them in the foreseeable future; however, there is also no hint putting them into question.

Competing descriptions of the universe have not been successful in matching these predictions. In addition, theoretical arguments state that with matter distributions such as

Ref. 62

* The difference between the total matter density and the separately measurable baryonic matter density, only about one sixth of the former value, is also not explained yet. It might even be that the universe contains matter of a type unknown so far. This issue is called the *dark matter problem*; it is one of the important unsolved questions of cosmology.

* Fred Hoyle (1915–), important British astronomer and astrophysicist.

** The theory states that $T_\nu/T_\gamma \approx (4/11)^{1/3}$. These neutrinos appeared about 0.3 s after the big bang.

the observed one, plus some rather weak general assumptions, there is no known way to avoid a period in the *finite* past in which the universe was extremely small. Therefore it is worth having a close look at the situation.

Ref. 63

Was the big bang a big bang?

Was it a kind of explosion? An explosion assumes that some material transforms internal energy into motion of its parts. There has not been any such process in the early history of the universe. The origin for the initial velocity of matter is *unknown* at this point of our mountain ascent. One cannot call the whole phenomenon an explosion at all. And obviously there neither was nor is any air in interstellar space, so that one cannot speak of a ‘bang’ in any sense of the term.

Was it big? The universe was rather small about twelve thousand million years ago, much smaller than an atom. In summary, the big bang was neither big nor a bang; only the rest is correct.

Was the big bang an event?

The big bang is a description of what happened in the *whole* of space-time. Despite what is often written in bad newspaper articles, at every moment of the expansion, space is always of non-vanishing size; space *never* was a single point. People who pretend this are making at first sight plausible, but false statements. The big bang is a description of the *expansion* of space-time, not of its beginning. Following the motion of matter back in time, general relativity cannot deduce the existence of an initial singularity. The issue of measurement errors is probably not a hindrance; however, the effect of the nonlinearities in general relativity at situations of high energy densities is not clear.

Most importantly, quantum theory shows that the big bang was *not* a singularity, as no observable, neither density nor temperature, reaches an infinitely large or infinitely small value, since such values cannot exist in nature.* In any case, there is a general agreement that arguments based on *pure* general relativity alone cannot make correct statements on the big bang. Most newspaper article statements are of this sort.

See page 711

Was the big bang a beginning?

Asking what was before the big bang is like asking what is north of the north pole. Since nothing is north of the north pole, nothing ‘was’ before the big bang.

This analogy could be misinterpreted to imply that the big bang took its start at a single point in time, which of course is incorrect, as just explained. But the analogy is better than it looks; in fact, there is *no* precise north pole, since quantum theory shows that there is a basic uncertainty on its position. There is also a corresponding uncertainty for the big bang.

In fact, it does not take more than three lines to show with quantum theory that time and space are *not* defined either at or near the big bang. We will give this simple argument in the first chapter of the third part of the mountain ascent. The big bang therefore cannot be

See page 675

* Many physicists are still wary to make such strong statements at this point. The first sections of the third part of the mountain ascent give the precise arguments leading to them.

See page 669

called a ‘beginning’ of the universe. There never was a time when the scale factor $R(t)$ of the universe was zero. This conceptual mistake is frequently encountered. Near the big bang, events can *neither* be ordered *nor* even be defined. More bluntly, there is *no* beginning; there has never been an initial event or singularity, despite the numerous statements pretending the contrary.

Obviously the concept of time is not defined ‘outside’ or ‘before’ the existence of the universe; this fact was clear to thinkers already over thousand years ago. It is then tempting to conclude that time must have *started*. But as we saw, that is a logical mistake as well: first of all, there is no starting event, and secondly, time does not flow, as clarified already in the beginning of our walk.

A similar mistake lies behind the idea that the universe ‘had certain initial conditions.’ Initial conditions *by definition* make only sense for objects or fields, i.e. for entities which can be observed from the outside, i.e. for entities which have an environment. The universe does not comply to these requirements; the universe thus cannot have initial conditions. Nevertheless, many people still insist on thinking about the issue; interestingly, Steven Hawking sold millions of books explaining that a description without initial conditions is the most appealing, overlooking that there is no other possibility anyway. This statement will still lead to strong reactions among physicists; it will be discussed in more detail in the section on quantum theory.

In summary, the big bang does not contain a beginning nor does it imply one. We will uncover the correct way to think about it in the third part of our mountain ascent.

Does the big bang imply creation?

[The general theory of relativity produces]
universal doubt about god and his creation
A US-American witch hunter

Creation, i.e. the appearance of something out of nothing, needs an existing concept of space and time to make sense. The concept of ‘appearance’ makes no sense otherwise. But whatever the description of the big bang, be it classical, as in this chapter, or quantum mechanical, as in later ones, this condition is never fulfilled. Even in the present, classical description of the big bang, which gave origin to its name, there is *no* appearance of matter, nor of energy, nor of anything else. And this situation does not change in any latter, improved description, as time or space are never defined *before* the appearance of matter.

In fact, all properties of a creation are missing; there is no ‘moment’ of creation, no appearance from nothing, no possible choice of any ‘initial’ conditions out of some set of possibilities, and as we will see in more detail later on, not even any choice of particular physical ‘laws’ from any set of possibilities.

In summary, the big bang does not imply nor harbour a creation process. The big bang was not an event, not a beginning, and *not* a case of creation. It is impossible to continue the ascent of Motion Mountain if one cannot accept each of these three conclusions. If one denies them, one has decided to continue in the domain of beliefs, thus effectively giving up on the mountain ascent.

Note that this requirement is not new. In fact, it was already contained in equation (1) at the start of our walk, as well as in all the following ones. It appears ever more clearly at this

Ref. 64

See page 43

See page 107

Ref. 65

Challenge 282

See page 462

Challenge 299

See page 45

point. But what then *is* the big bang? We'll find out in the third part.

We now return to the discussion of what the stars can tell us about nature.

Why can we see the sun?

First of all, because air is transparent. That is not self-evident; in fact air is transparent only to *visible* light and to a few selected other frequencies. Infrared and ultraviolet radiation are mostly absorbed. The reasons lie in the behaviour of the molecules the air consists of, namely mainly nitrogen, oxygen, and a few other transparent gases. Several moons and planets in the solar system have opaque atmospheres; we are indeed lucky to be able to see the stars at all.

In fact, even air is not completely transparent; air molecules *scatter* light a little bit. That is why the sky and far away mountains appear blue and sunsets red,* and stars are invisible during daylight.

Secondly, we can see the sun because the sun, like all hot bodies, *emits* light. We describe the details of *incandescence*, as this effect is called, below.

See page 397

Thirdly, we can see the sun because we and our environment and the sun's environment are *colder* than the sun. In fact, incandescent bodies can be distinguished from their background only if the background is colder. This is a consequence of the properties of incandescent light emission, usually called *black body radiation*. The radiation is material independent, so that for an environment with the same temperature as the body, one cannot see anything at all. Just have a look on the photograph of page 400 as a proof.

Finally, we can see the sun because it is not a black hole. If it were, it wouldn't emit (almost) any light, as we will see shortly.

Obviously, each of these conditions applies for stars as well. For example, we can only see them, because the night sky is black. But then,

Why are the colours of the stars different?

Stars are visible because they emit visible light. We encountered several important effects which determine colours: the varying temperature among the stars, the Doppler shift due to a relative speed with respect to the observer, and the gravitational red shift.

See page 398

Not all stars are good approximations of black bodies, so that the black body radiation law sometimes is not an accurate description for their colour. However, most of the stars are good approximations of black bodies. The temperature of a star depends mainly on its size, its mass, its composition, and its age, as the astrophysicists are happy to explain. Orion

Ref. 75

* Air scattering makes the sky blue also at night, as can be proven by long time exposure cameras; however our eyes are not able to perform this trick, and the low levels of light make it black to us.

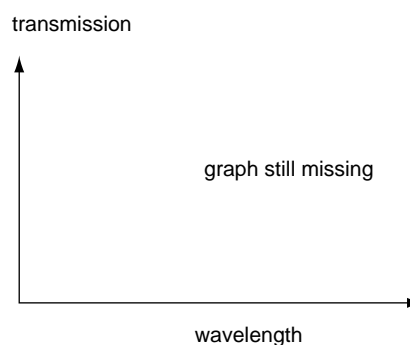

Figure 131 The absorption of the atmosphere

is a good example of a coloured constellation; each star has a different colour. Long term exposure photographs beautifully show this.*

Table 28 The colour of the stars

Class	temperature	example	position	colour
O	30 kK	Mintaka	δ Orionis	blue-violet
O	31 ± 10 kK	Alnitak	ζ Orionis	blue-violet
B	22(6) kK	Bellatrix	γ Orionis	blue
B	kK	Saiph	χ Orionis	blue-white
B	kK	Rigel	β Orionis	blue-white
B	kK	Alnilam	ε Orionis	blue-white
B	17(5) kK	Regulus	α Leonis	blue-white
A	9.9 kK	Sirius	α Canis Majoris	blue-white
A	8.6 kK	Megrez	δ Ursae Majoris	white
A	7.6(2) kK	Altair	α Aquilae	yellow-white
F	7.4(7) kK	Canopus	α Carinae	yellow-white
F	6.6 kK	Procyon	α Canis Minoris	yellow-white
G	5.8 kK	Sun	ecliptic	yellow
K	3.5(4) kK	Aldebaran	α Tauri	orange
M	2.8(5) kK	Betelgeuse	α Orionis	red

The basic colour determined by temperature is changed by two effects. The first, the *Doppler red shift*, depends on the speed v between source and observer following

Challenge 316

$$z = \frac{\Delta\lambda}{\lambda} = \frac{f_S}{f_O} - 1 = \sqrt{\frac{c+v}{c-v}} - 1 \quad . \quad (296)$$

Such shifts only play a significant role only for far away, and thus faint stars visible through the telescope. With the naked eye, Doppler shifts cannot be seen. But Doppler shifts can make far away stars shine in the infrared instead of in the visible domain. Indeed, the highest Doppler shifts observed for luminous objects are larger than 5, corresponding to more than 94% of the speed of light. Note that in the universe, the red shift is also related to the scale factor R by

Challenge 333

$$z = \frac{R(t_0)}{R(t_{\text{emission}})} - 1 \quad . \quad (297)$$

Light at a red shift of 5 thus was emitted at an age a quarter of the present.

The other colour changing effect, the *gravitational red shift*, depends on the matter density of the source and is given by

$$z = \frac{\Delta\lambda}{\lambda} = \frac{f_S}{f_O} - 1 = \frac{1}{\sqrt{1 - \frac{2GM}{c^2 R}}} - 1 \quad . \quad (298)$$

It is usually quite a bit smaller than the Doppler shift. Can you confirm this?

Challenge 350

Other red shift processes are not known; moreover, such processes would contradict all the properties of nature we know. But the colour issue leads to the next question:

See page 309

* See for example the book ...

Are there dark stars?

It could be that some stars are not seen because they are dark. This possibility of dark matter, if widespread, would lead to incorrect matter density estimates for the universe, and thus to incorrect evolution predictions for its fate. This issue is therefore hotly debated. It is known that objects more massive than Jupiter but less massive than the sun can exist in states which do not emit almost any light. They are also called *brown dwarfs*. It is unclear at present how many such objects exist. Many of the so-called extrasolar ‘planets’ are probably brown dwarfs. The issue is not closed.

Another possibility for dark stars are black holes. They are discussed in detail in a separate section below.

Are all stars different? – Gravitational lenses

Per aspera ad astra.

Are we sure that at night, two stars are really different? The answer is no. Recently, it was shown that two stars were actually two images of the same object. This was found by comparing the flicker of two different images. It was found that the flicker of one image was exactly the same as the other, just shifted by 423 days. This heroic result was found by Johannes Pelt from Estonia, and his research group, while observing two quasar images of the system Q0957+561.

Ref. 76

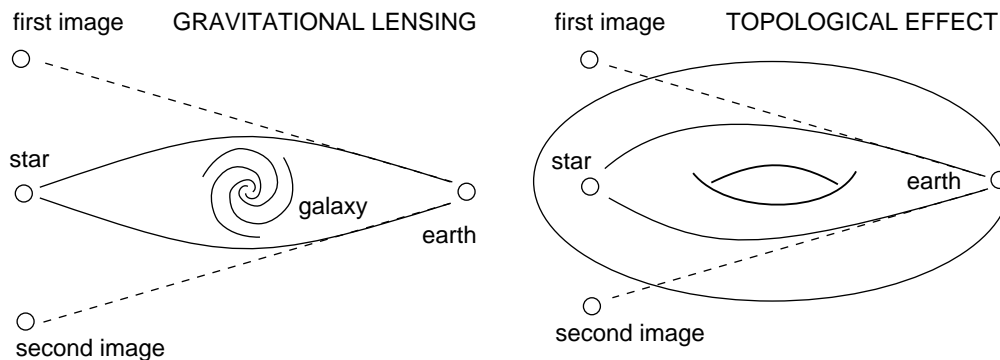

Figure 132 How one star can lead to several images

The two images are the result of *gravitational lensing*. Indeed, a large galaxy can be seen between the two images, at much smaller distance from the earth. This effect was already considered by Einstein; however he did not believe that it was observable. The real father of gravitational lensing is Fritz Zwicky, who predicted in 1937 that the effect would be quite frequent and easy to observe, if one considered lined up galaxies instead of lined up stars, as indeed it turned out to be the case.

Ref. 77

Challenge 367

Interestingly, when the time delay is known, astronomers are able to determine the size of the universe from this observation. Can you imagine how?

In fact, if the two objects one observes are lined up behind each other, one sees the more distant one as *ring* around the nearer one. Such rings have indeed been observed, and the

object B1938+666 is one of the most beautiful ones. Using this method, some astronomer are even trying to find earth-like planets around other stars.

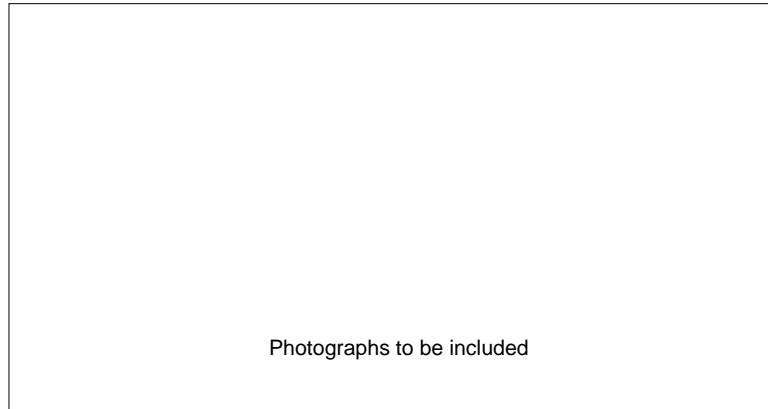

Figure 133 The Zwicky-Einstein ring B1938+666 and multiple galaxy images around CL0024+1654

Generally speaking, nearby stars are truly different, but for the far away stars the problem is tricky. For single stars, the issue is not so important, seen overall. Reassuringly, about 40 double star images have been identified so far. But when whole galaxies are seen as several images at once, and several dozens are known so far, one starts to get nervous. In the case of CL0024+1654, the image of the distant galaxy is seen seven times around the image of the nearer mass.

In these situations, apart from lensing, also the *shape* of the universe could play some tricks.

What is the shape of the universe?

There is a standard explanation to avoid some of the just mentioned problems. The universe in its evolution is similar to the surface of an ever increasing sphere: the surface is finite, but it has no boundary. The universe simply has an additional dimension; therefore its volume is also ever increasing, finite, but without boundary. This statement presupposes that the universe has the same topology, the same 'shape' as that of a sphere with an additional dimension.

But what is the experimental evidence for this statement? Nothing. Nothing is yet known about the shape of the universe. It is extremely hard to determine it, because of its sheer size. Ref. 78

What do experiments say? In the nearby region of the universe, say a few million light years, the topology is simply connected. But for large distances, almost nothing is sure. Maybe research into gamma ray bursts will provide a way to determine topology, as these bursts often originate from the dawn of time, and thus might tell something about the topology.* Maybe even the study of fluctuations of the cosmic background radiation can tell something about the topology. All this research is still in its infancy.

* The story is told from the mathematical point of view by BOB OSSERMAN, *Poetry of the universe*, 1990.

Since little is known, one can ask about the range of possible answers. As just mentioned, in the standard model with $k = 1$, space-time is usually assumed to be a product of linear time, with the topology R of the real line, and a sphere S^3 for space. That is the simplest possible shape, corresponding to a *simply connected* universe. For $k = 0$, the simplest topology of space is three-dimensional real space R^3 , and for $k = -1$ it is a hyperbolic manifold H^3 .

See page 291 In addition, Figure 128 showed that depending on the value of the cosmological constant, space could be finite and bounded, or infinite and unbounded. In all Friedman-LeMaître calculations, simple connectedness is usually tacitly assumed, even though it is not at all required.

It could well be that space-time is *multiply* connected, like a higher-dimensional version of a torus. It could also have even more complex topologies.* In these cases, it could even be that the actual number of galaxies is much smaller than the observed number. This situation would correspond to a kaleidoscope, where a few stones produce a large number of images. In addition, topological surprises could also be hidden *behind* the horizon.

See page 710 In fact, the range of possibilities is not limited to the simply and multiply connected cases suggested by classical physics. An additional and completely unexpected twist will appear in the third part of our walk, when quantum theory is included in the investigations.

What is behind the horizon?

The universe is a big place;
perhaps the biggest.
Kilgore Trout

Ref. 80 The horizon is a tricky entity. In fact, all cosmological models show that it moves rapidly away from us. A detailed investigation shows that for a matter dominated universe it moves away from us with a velocity

Challenge 384

$$v_{\text{horizon}} = 3c \quad . \quad (299)$$

A pretty result, isn't it? Obviously, since the horizon does not transport any signal, this is not a contradiction with relativity. But what is behind the horizon?

Challenge 401 If the universe were *open* or *marginal*, the matter we see at night would only be a – literally – infinitely small part of all existing matter, since an open or marginal universe implies that there is an infinite amount of matter behind the horizon. Is such a statement verifiable? In other words, is such a statement a belief or a fact?

Unfortunately, a *closed* universe fares only slightly better. Matter is still predicted to exist behind the horizon; however, in this case it is only a finite amount.

In short, the standard model of cosmology states that there is a lot of matter behind the horizon. The question is still open. The most precise description is provided by the hypothesis of inflation.

Ref. 79 * The FLRW metric is also valid for any quotient of the just mentioned simple topologies by a group of isometries, leading to dihedral spaces and lens spaces in the case $k = 1$, to tori in the case $k = 0$, and to *any* hyperbolic manifold in the case $k = -1$.

Why are there stars all over the place? – Inflation

What were the initial conditions of matter? Obviously it was roughly a constant density over space. How could this happen? The person to have asked this question most thoroughly was Alan Guth.

– CS – to be added – CS –

Why are there so few stars? The energy and entropy content of the universe

Die Energie der Welt ist constant.
Die Entropie der Welt strebt einem Maximum zu. *
Rudolph Clausius

The matter-energy density of the universe is near the critical one. Inflation, described in the previous section, is the favourite explanation for this connection. That implies that the actual number of stars is given by the behaviour of matter at extremely high temperatures, and by the energy density left over at lower temperature. The precise connection is still the topic of intense research. But this issue also raises a question about the section quote. Was the creator of the term ‘entropy’, Rudolph Clausius, right when he made this famous statement? Let us have a look to what general relativity has to say about all this.

In general relativity, a *total* energy can indeed be defined, in contrast to *localized* energy, which cannot. The total energy of all matter and radiation is indeed a constant of motion. It is given by the the sum of the baryonic part, the radiation part, and the neutrino part:

$$E = E_b + E_\gamma + E_\nu \approx \frac{c^2 M_0}{T_0} + \dots + \dots \approx \frac{c^2}{G} + \dots \quad (300)$$

This value is constant only when integrated over the whole universe, not when the inside of the horizon only is taken. **

Many people also add a gravitational energy term. If one tries to do so, one is obliged to define it in such a way that it is exactly the negative of the previous term. This value for the gravitational energy leads to the popular speculation that the *total* energy of the universe might be zero. In other words, the number of stars could be limited also by this relation.

However, the discussion of *entropy* puts a strong question mark behind all these seemingly obvious statements. Many people try to give values for the entropy of the universe. Some checked whether the relation

Ref. 81

$$S = \frac{kc^3}{G\hbar} \frac{A}{4} = \frac{kG}{\hbar c} 4\pi M^2 \quad , \quad (301)$$

correct for black holes, also applies to the universe, hereby assuming that all the matter and all the radiation of the universe can be described by some average temperature. They argue that the entropy of the universe is obviously low, so that there must be some ordering principle behind it. Others even speculate where the entropy of the universe comes from, and whether the horizon is the source for it.

Challenge 418

* The energy of the universe is constant. Its entropy tends towards a maximum.

** Except for the case when pressure can be neglected.

But let us be careful. Clausius assumes, without the slightest doubt, that the universe is a closed system, and thus deduces the above statement. Let us check this assumption. Entropy describes the maximum energy one can extract from a hot object. After the discovery of the particle structure of matter, it became clear that entropy is also given by the number of microstates looking like a specific macrostate. But both definitions make no sense if one applies them to the universe as a whole. There is no way to extract energy from it, and no way to say how many microstates of the universe would look like the macrostate.

The basic reason is the impossibility to apply the concept of *state* to the universe. In the beginning, we defined a state as those properties of a system which allow to distinguish it from other systems with the same intrinsic properties, or which differ from one observer to the other. You might want to check for yourself that for the universe, such state properties do not exist at all!

Challenge 435

If there is no state of the universe, there is no entropy for it. And neither an energy value. This is in fact the only correct conclusion one can take about the issue.

Why is matter lumped?

We are able to see the stars because the universe consists mainly of empty space, in other words, because stars are small and far apart. But why is this the case? Cosmic expansion was deduced and calculated using a homogeneous mass distribution. So why did matter lump together?

It turns out that homogeneous mass distributions are *unstable*. If for any reason the density fluctuates, regions of higher density will attract matter and increase in density, whereas regions of lower density will deplete. Can you confirm the instability, simply by assuming a space filled with dust and $a = GM/r^2$?

But how did the first inhomogeneities form? That is one of the big problems of modern physics and astrophysics, and there is no accepted answer yet.

Several modern experiments try to measure the variations of the cosmic background radiation spectrum with angular position and with polarisation; these results, which will be available in the coming years, might provide some information on the way to settle the issue.

Ref. 82

Why are stars so small compared with the universe?

Given that the matter density is around the critical one, the size of stars, which contain most of the matter, is a result of the interaction of the elementary particles composing them.

See page 311

Below we will show that general relativity (alone) cannot explain any size appearing in nature. The discussion of this issue is a theme of quantum theory.

Are stars and galaxies moving apart or is the universe expanding?

Can one distinguish between expanding space and galaxies moving apart? Yes, one can. Are you able to find an argument or to devise an experiment to do so?

Challenge 452

Does the expansion of the universe also apply to the space on the earth? No. The expansion is calculated for a homogeneous and isotropic mass distribution. Matter is not homogeneous nor isotropic inside the galaxy; the approximation of the cosmological principle is not

valid down here. It has been checked experimentally by studying atomic spectra in various places in the solar system that on its scale there is *no* Hubble expansion taking place.

Ref. 83

Is there more than one universe?

That is another possible direction to study the question whether we see all the stars. In fact, you might check that neither definition of universe given above, be it ‘all matter-energy’ or ‘all matter-energy and all space-time’, allows to answer the question positively.

Challenge 469

There is no way to define a plural for universe: either the universe is everything, and then it is unique, or it is not everything, and then it is not the universe. We will discover that quantum theory does not change this conclusion, despite recurring reports of the contrary.

See page 556

Why are the stars fixed? – Arms, stars, and Mach's principle

The two arms of humans played an important role in discussions about motion, and especially in the development of relativity. Looking at the stars at night, one can make a simple observation, if one keeps one's arms relaxed. Standing still, our arms hang down. Then we turn rapidly. Our arms lift up; in fact they do so whenever the stars turn. Some people have spent their lives on this connection. Why?

The observation shows that motion is obviously relative, not absolute. Stars and arms prove this connection. * This observation leads to two possible formulations of what Einstein called *Mach's principle*.

Ref. 84

- *Inertial frames are determined by the rest of the matter in the universe.*

This idea is indeed realized in the description of nature via general relativity. No question about it.

- *Inertia is due to the interaction with the rest of the universe.*

This formulation is more controversial. Many interpret this formulation as meaning that the *value of mass* itself depends on the distribution of mass in the rest of the universe. That would mean that one needs to investigate whether mass is non-isotropic when a large body is nearby. Of course, this question has been studied experimentally; one simply needs to measure whether a particle has the same mass values when accelerated in different directions. Unsurprisingly, to a high degree of precision, no such non-isotropy has been found. Due to this result, many conclude that Mach's principle is wrong. Others conclude with some pain in their stomach that the whole topic is not yet settled.

Ref. 85

Ref. 86

But in fact it is easy to see that Mach *cannot* have meant a mass variation at all: one then would also have to conclude that mass should be distance dependent, and that this should be so even in Galilean physics. But this statement is indeed known to be wrong, and nobody in his right mind has ever had any doubts about it.

Challenge 486

The whole story is due to a misunderstanding of what is meant by ‘inertia’: one can interpret it as inertial *mass* or as inertial *motion* (like the moving arms under the stars). There is no evidence that Mach believed either in non-isotropic mass nor in distance-dependent mass; the whole discussion is an example of the frequent game consisting of being proud of not making a mistake which is incorrectly imputed to a supposedly more stupid other

* The original reasoning by Newton and many others around this situation used a bucket and the surface of the water in it; but the arguments are the same.

person. At school one usually hears that Columbus was derided because he thought the earth to be spherical. But he was not derided at all for this reason; there were only disagreements on the *size* of the earth, and in fact it turned out that his critics were right, and that he was wrong with his own, much too small radius estimate.

The same happened with Mach's principle. Obviously, inertial effects do depend on the distribution of mass in the rest of the universe. Mach's principle is correct. Mach made some blunders in his life (he is in-famous for fighting the idea of atoms until he died, against experimental evidence) but his principle is *not* one of them, in contrast to the story told in many textbooks. But it is to be expected that the myth about the incorrectness of Mach's principle will persist, like that of the derision of Columbus.

Ref. 86

In fact, Mach's principle is valuable. As an example, take our galaxy. Experiments show that she is flattened and rotating. The sun turns around her centre in about 250 million years. Indeed, if the sun would not turn around the galaxy's centre, we would fall into it in about 20 million years. As the physicist Dennis Sciama pointed out, from the shape of our galaxy we can take a powerful conclusion: there must be a lot of other matter, i.e. a lot of other stars and galaxies in the universe. Are you able to confirm his reasoning?

Challenge 503

Resting in the universe

There is no preferred frame in special relativity, no absolute space. Is the same true in the actual universe? No; there *is* a preferred frame. Indeed, in the standard big-bang cosmology, the average galaxy is at rest. Even though we talk about the big bang, any average galaxy can rightly maintain that it is at rest. Each one is in free fall. An even better realization of this privileged frame of reference is provided by the background radiation.

In other words, the night sky is black because we move with almost no speed through background radiation. If the earth had a large velocity relative to the background radiation, the sky would be bright at night, at least in certain directions. Can you confirm this?

Challenge 520

The reason why the galaxy and the solar system move with small speed across the universe has been already studied in our walk. Can you give a summary?

Challenge 537

By the way, is the term 'universe' correct? Does the universe rotate, as its name implies? If by universe one means the whole of experience, the question does not make sense, because rotation is only defined for bodies, i.e. for parts of the universe. However, if by universe one only means 'all matter', the answer *can* be determined by experiments. It turns out that the rotation is extremely small, if there is any. In short, he who talks about the universe is really lying!

Ref. 87

Does light attract light?

Another reason that we can see stars is that their light reaches us. Do parallel light beams remain parallel? If light is energy, and energy attracts energy through gravitation, light should *attract* light. That could have strange effects on the light emitted by stars.

Interestingly, a precise calculation shows that gravitation does *not* alter the path of two parallel light beams, even though it *does* alter the path of antiparallel light beams. The reason is that for parallel beams moving at light speed, the gravitomagnetic component exactly *cancels* the gravitoelectric component.

Ref. 88

Challenge 554

Since light does not attract light moving along, light will not be disturbed by its own gravity during the millions of years that it takes from distant stars to reach us.

Does light decay?

In the section on quantum theory we will encounter experiments showing that light is made of particles. It could be that these photons *decay* into some other particle, as yet unknown, or into lower frequency photons. If that would happen, we would not be able to see far away stars.

But any decay would also mean that light would change its direction (why?) and thus produce blurred images for far away objects. However, no blurring is observed. In addition, the soviet physicist Bronstein demonstrated in the 1930s that any light decay process would have a larger rate for smaller frequencies. So people checked the shift of radio waves, in particular the famous 21 cm line, and compared it with the shift of light from the same source. No difference was found for all galaxies tested.

Challenge 571

Ref. 89

People even checked that Sommerfeld's fine structure constant, the constant of nature which determines the colour of objects, does not change over time. No sizeable effect could be detected over thousands of millions of years.

Ref. 90

Of course, instead of decaying, light could also be *hit* by some so far unknown entity. But also this case is excluded by the just presented arguments. In addition, these investigations show that there is no additional red shift mechanism in nature apart from Doppler and gravitational red shifts.

Challenge 588

See page 301

In summary, the fact that we can see the stars at night yields numerous properties of nature. We now continue our mountain ascent with a more fundamental issue, nearer to our quest for the fundamentals of motion.

10. Does space differ from time?

Tempori parce.
Seneca*

People in bad mood say that time is our master. Nobody says that of space. Time and space are obviously different in everyday life. But what is the precise difference between them in general relativity? And do we need them at all? These questions by themselves form an important topic.

In general relativity it is assumed that we live in a (pseudo-riemannian) space-time of variable curvature. The curvature is an observable and is related to the distribution and motion of matter and energy in the way described by the field equations.

However, there is a fundamental problem. The equations of general relativity are invariant under numerous transformations which *mix* the coordinates x_0 , x_1 , x_2 and x_3 . For example,

* 'Care about time.' Lucius Annaeus Seneca (ca. 4 BCE–65), *Epistolae* 88, 39

the transformation

$$\begin{aligned}x'_0 &= x_0 + x_1 \\x'_1 &= -x_0 + x_1 \\x'_2 &= x_2 \\x'_3 &= x_3\end{aligned}\tag{302}$$

Challenge 605

is allowed in general relativity, and leaves the field equations invariant. You might want to search for other examples.

The consequence is clear: diffeomorphism invariance makes it *impossible* to distinguish space from time *inside* general relativity. This surprising conclusion is in sharp contrast with everyday life.

More explicitly, the coordinate x^0 cannot simply be identified with the physical time t , as implicitly done up to now. This identification is only possible in *special* relativity. In special relativity the invariance under Lorentz (or Poincaré) transformations of space and time singles out energy, linear, and angular momentum as the fundamental observables. In general relativity, there is *no* metric isometry group; consequently, there are *no* basic physical observables singled out by their characteristic of being conserved. But invariant quantities are necessary for communication! In fact, we can *talk* to each other only because we live in an approximately *flat* space-time. If the angles of a triangle would not add up to 180 degrees, we could not communicate, since there would be no invariant quantities.

So how did we sweep this problem under the rug so far? We used several ways. The simplest way was to always require that in some part of the situation under consideration space-time is our usual flat Minkowski space-time, where x_0 can be set equal to t . This requirement can be realized either at infinity, as we did around spherical masses, or in zeroth approximation, as we did for gravitational radiation and for all other perturbation calculations. In this way, the free mixing of coordinates is eliminated and the otherwise missing invariant quantities appear as expected. This pragmatic approach is the usual way out of the problem. In fact, there are otherwise excellent texts on general relativity refusing any deeper questioning of the issue.

Ref. 74

A common variation of this trick is to let the distinction ‘sneak’ into the calculations by the introduction of matter and its properties, or by the introduction of radiation. Both matter and radiation distinguish between space and time simply by their presence. The material properties of matter, for example their thermodynamic state equations, always distinguish space and time. Radiation does the same, by its propagation. Obviously this is true also for those special combinations of matter and radiation called clocks and meter bars. In fact, the method of introducing matter is the same as the one introducing Minkowski space-time, if one looks closely: matter properties are always defined using space-time descriptions of special relativity.*

Still another variation of the pragmatic approach is the use of the cosmological time coordinate. An isotropic and homogeneous universe does have a preferred time coordinate,

Challenge 622

* We note something astonishing here: the inclusion of some condition at small distances (matter) has the same effect as the inclusion of some condition at infinity. Is this a coincidence? We will come back to this issue in the third part of the mountain ascent.

namely the one used in all the tables on the past and the future of the universe. Also here one is in fact using a combination of the previous two ways.

But we are on a special quest here. We want to *understand* motion, not only to calculate its details. We want a *fundamental* answer, not a pragmatic one. And for this we need to know how the x_i and time t are connected, and how we can define invariant quantities. This question prepares us for the moment when gravity is combined with quantum theory, as we will do in the third part of our mountain ascent.

A fundamental solution requires to describe clocks together with the system under consideration, and deduce how the reading t of the clock relates to the behaviour of the system in space-time. But we note that any description of a system requires measurements, e.g. to determine the initial conditions. We enter a vicious circle, since that is what we wanted to avoid in the first place.

We get a suspicion. Does a fundamental difference between space and time exist at all? Let us have a tour of the various ways to investigate the question.

Can space and time be measured?

In order to distinguish space and time in general relativity, one must be able to measure them. But already in the section on universal gravity we had mentioned the impossibility of measuring lengths, times and masses with gravitational effects alone. Does this situation change in general relativity? Lengths and times are connected by the speed of light, and in addition lengths and masses are connected by the gravitational constant. Despite this additional connection, it takes only a moment to convince oneself that the problem persists. In fact, one needs *electrodynamics* to solve it. Only using the electromagnetic charge e one can form length scales, of which the most simple one is given by

See page 166

$$l_{\text{scale}} = \frac{e}{\sqrt{4\pi\epsilon_0}} \frac{\sqrt{G}}{c^2} \approx 1.4 \cdot 10^{-36} \text{ m} . \quad (303)$$

In fact, only *quantum mechanics* provides a real solution to this issue, as can be seen by rewriting the elementary charge e as the combination of nature's fundamental constants, namely

$$e = \sqrt{4\pi\epsilon_0 c \hbar \alpha} , \quad (304)$$

which changes expression (303) into

$$l_{\text{scale}} = \sqrt{\frac{\alpha \hbar G}{c^3}} = \sqrt{\alpha} l_{\text{Pl}} . \quad (305)$$

The expression shows that every length measurement is based on the electromagnetic coupling constant α and on the Planck length. Of course, the same is valid for time and mass measurements. There is no way to define or measure lengths, times and masses in general relativity alone.* Therefore, the answer to the section title being negative in general relativity, the next question is:

Challenge 639

Ref. 91 * In the past, John Wheeler used to state that his *geometrodynamic clock*, a device which measures time by bouncing back and forward between two parallel mirrors, was a counterexample; that is not correct, however.

Challenge 656 Can you confirm this?

Are space and time necessary?

Ref. 92 Robert Geroch answers this question in a beautiful five-page article. He explains how to formulate the general theory of relativity without the use of space and time, by taking as starting point the physical observables only.

He starts with the set $\{a\}$ of all observables. Among them there is one, called v , standing out, because it allows to say that for any two observables a_1, a_2 there is a third one a_3 , for which

$$(a_3 - v) = (a_1 - v) + (a_2 - v) \quad . \quad (306)$$

Such an observable is called the *vacuum*. Once such an observable is known, Geroch shows how to use it to construct the derivatives of observables. Then the so-called Einstein algebra can be built, which comprises the whole of general relativity.

Usually one describes motion by deducing space-time from matter observables, by calculating the evolution of space-time, and then by deducing the motion of matter following from it. Geroch's description shows that the middle step, the use of space and time, is not necessary.

What does one conclude? It is possible to formulate general relativity without the use of space and time. But if they are both unnecessary, it is unlikely that there is fundamental difference between them. Still, one difference between time and space is well-known:

Do closed timelike curves exist?

In other words, is it possible that the time coordinate behaves, at least in some regions, like a torus? Is it possible, like in space, to come back in time from where one has started?

Ref. 63 The question has been studied in great detail. The standard reference is the text by Hawking and Ellis; they list the various properties of space-time compatible with each other or excluding each other. Among others, they find that space-times which are smooth, globally hyperbolic, oriented and time-oriented do not contain any such curves. It is usually assumed that this is the case for the universe, so that nobody expects to observe closed timelike curves.

That seems to point to a difference. But in fact, these investigations do not help: they are based on the behaviour of matter. Thus these arguments right from the start imply an answer and do not allow to search for it. In short, also this topic cannot help to decide whether space and time differ. Let us look at the issue in another way.

Is general relativity local? – The hole argument

When Albert Einstein developed general relativity, he had quite some trouble with diffeomorphism invariance. Most startling is his famous *hole argument*, better called the *hole paradox*.

Ref. 93 Take the situation shown in Figure 134, in which a mass deforms the space-time around it. Einstein imagined a small region of the vacuum, the *hole*, which is shown with a dotted line. What happens if one changes the curvature inside the hole while leaving the situation outside it unchanged, as shown in the inset of the picture?

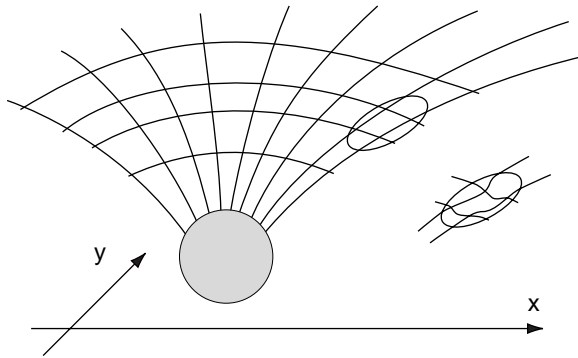

Figure 134 A 'hole' in space

On the other hand, general relativity is diffeomorphism invariant. The deformation shown in the figure is a diffeomorphism. The situation must be physically equivalent to the original situation.

Who is right? Einstein first favoured the first point of view, and therefore dropped the whole idea of diffeomorphism invariance for about a year. Only later he understood that the second assessment is correct, and that the first statement makes a fundamental mistake.

Indeed, the first opinion arrives to the conclusion that the two situations are different because it assumes an independent existence of the coordinate axes x and y shown in the figure. But during that deformation, the coordinates x and y automatically change as well, so that there is *no* physical difference between the two situations.

The moral of the story is that *there is no difference between space-time and gravitational field*. Space-time is a quality of the field, as Einstein put it, not an entity with separate existence, as assumed in the graph. Coordinates have no physical meaning; only distances in space and time have one. In particular, diffeomorphism invariance proves that *there is no flow of time*. Time, like space, is only a relational entity: time and space are relative; they are not absolute.

This relativity also has practical consequences. For example, it turns out that many problems in general relativity are equivalent to the Schwarzschild situation, even though they appear completely different. As a result, researchers have 'discovered' the Schwarzschild solution (of course with different coordinate systems) over twenty times, often thinking that they had found a new, unknown solution.

Diffeomorphism invariance will play a central role in the third part of our mountain ascent. But already here the topic has a startling consequence:

Is the earth hollow?

We live on the inside of a sphere, as is proven by any pair of shoes.
The soles are used up at both ends, and hardly at all in the middle.
Anonymous

The *hollow earth hypothesis*, i.e. the conjecture that we live on the *inside* of a sphere, was popular in paranormal circles around the year 1900, and still is among certain crackpots today. These strange people propagate the idea on the internet, explaining that humans live on the *inside* of a sphere, with the sun somewhere on the way to the centre, the stars even

nearer to the centre, etc. They state that we are fooled by education into the usual description, because we are brought up to believe that light travels in straight lines. Get rid of this belief, they say, and the hollow earth appears in all its glory.

Interestingly, there is *no way* to disprove this sort of description of the universe. In fact, the diffeomorphism invariance of general relativity even proclaims the equivalence between the two views. The fun starts when either of the two camps wants to tell the other than *only* its own description is correct. You might check that any such argument is wrong; it is fun to slip into the shoes of such a crackpot and to defend the hollow earth hypothesis against your friends. Both descriptions are exactly equivalent.

Challenge 673

Are you able to confirm that even quantum theory, with its introduction of length scales into nature, does not change the situation? In fact, in the third part of our walk we will discover that there is a symmetry in nature quite similar to the change in viewpoint from the hollow earth view of crackpots to the standard view of physicists and back!

Challenge 690

See page 718

Are space, time and mass independent?

We conclude from this short discussion that there does not seem to be a fundamental distinction between space and time in general relativity. Pragmatic distinctions, using matter, radiation, or space-time at infinity are the only possible ones.

In the third part we will discover that even the inclusion of quantum theory is consistent with this view. We will show explicitly that no distinction is possible in principle. In addition, we will show that the origin of this impossibility is that mass and space-time are on equal footing and that in a sense, particles and vacuum are made of the same substance. The argument for these connections only takes a few lines. All distinctions turn out to be possible only at low, daily life energies.

See page 685

See page 111

In other words, in the beginning of our mountain ascent we saw that we needed matter to define space and time. Now we even found that we need matter to *distinguish* space and time. Similarly, in the beginning we saw that space and time are required to define matter; now we found that we even need *flat* space-time to define it.

In summary, general relativity does not answer several important questions about motion; it even makes the matter less clear than before! Continuing the mountain ascent is really worth the effort. To increase our understanding, we now tackle a completely different topic.

11. Black holes – falling forever

Why study them?

Black holes are the extreme case of general relativity; they realize the limit of length to mass ratio possible in nature. Therefore, they cannot be studied *without* general relativity. But in addition, black holes are a central stepping stone towards unification and the final description of motion. Strangely enough, for many years their existence was in doubt. The present experimental situation has lead most experts to conclude that there is one at the centre of at least 15 nearby galaxies, including our own; in addition, half a dozen smaller black holes have been identified scattered inside our own galaxy. In addition, black holes are suspected at the heart of quasars and of gamma rays bursters. It seems that the evolution

Ref. 96

of galaxies is strongly tied to the evolution of black holes. For this and many other reasons, black holes, the most impressive and the most relativistic systems in nature, are a fascinating subject of study.*

Horizons and orbits

An object whose escape velocity is larger than the speed of light c is called a *black hole*. They were first imagined by the British geologist John Michell in 1784 and independently by the French mathematician Pierre Laplace in 1795, long before general relativity. Even if they were hot shining stars, they would appear to be *black*, and not be visible in the sky. It only takes a short calculation to show that light cannot escape from a mass whenever the radius is smaller than a critical value given by

Ref. 97

Challenge 707

$$R_S = \frac{2GM}{c^2} \quad (307)$$

the so-called Schwarzschild radius. The formula is valid both in universal gravity and in general relativity, provided that in general relativity one takes the radius as meaning the circumference divided by 2π . That is exactly the limit value for length to mass ratios in nature. For this and other reasons to be given shortly, we will call R_S also the *size* of the black hole of mass M (although properly speaking it is only half the size). In principle, an object could be imagined to be smaller than this value; but nobody has observed one. As a note, the surface gravity of a black hole is given by

Challenge 724

$$g_{\text{surf}} = \frac{c^4}{4GM} = \frac{c^2}{2R_S} \quad (308)$$

Such a black star thus swallows what falls into it, be it matter or radiation, without letting anything out. It acts like a cosmic trash can. In 1967, John Wheeler** called them *black holes*.

As it is impossible to send light from a black hole to the outside world, what happens when a light beam is sent upwards from the horizon? And from slightly above the horizon?

Challenge 741

Black holes, when seen as astronomical objects, are thus different from planets. During the formation of planets, matter lumped together and as soon as it could not be compressed any further, equilibrium was formed, determining the radius of the planet. That is the same mechanism as when a stone is thrown towards the earth: it stops falling when it *hits* the ground thus formed. The bottom is reached when matter hits other matter. In the case of a black hole, there is no ground; everything *continues* falling. This happens, as we will see in the part on quantum theory, when the concentration of matter is so large that the forces which make matter *impenetrable* in daily life are overcome. As British physicist Freeman Dyson says, *a black hole is matter in permanent free fall*. In Russian, black holes used to be

* An excellent and entertaining book on the topic, without any formula, but nevertheless accurate and detailed, is the paperback by IGOR NOVIKOV, *Black holes and the universe*, Cambridge University Press, 1990.

** John Archibald Wheeler (1911–) US American physicist, important expert on general relativity and author of several excellent textbooks, among them the beautiful JOHN A. WHEELER, *A journey into gravity and space-time*, Scientific American Library & Freeman, 1990, in which he explains general relativity with passion and in detail, but without any mathematics.

called *collapsars*. Note that despite this permanent free fall, their radius remains constant. Due to this permanent free fall, black holes are the only state of matter in thermodynamic equilibrium! All other states are metastable. In 1939, Robert Oppenheimer* and Hartland Snyder showed theoretically that a black hole forms whenever a star of sufficient mass stops burning.

Ref. 99

The characterizing property of a black hole is its *horizon*. We have encountered horizons already in special relativity. Here the situation is similar; for an outside observer, the horizon is the surface beyond which he cannot receive signals. For black holes, the horizon is located at the gravitational radius.

The proof comes from the field equations. They lead to a space-time around a rotationally symmetric, thus non-rotating, and electrically neutral mass described by the Schwarzschild metric

See page 241

$$di^2 = \left(1 - \frac{2GM}{rc^2}\right) dt^2 - \frac{dr^2}{1 - \frac{2GM}{rc^2}} - r^2 d\phi^2 / c^2 \quad .$$

(309)

As mentioned above, r is the circumference divided by 2π , and t is the time measured at infinity. However, no *outside* observer will ever receive any signal emitted from $r = 2GM/c^2$ (or smaller)! Indeed, as the proper time of an observer at radius r is related to the one of an observer at infinity through

$$di = \sqrt{1 - \frac{2GM}{rc^2}} dt \quad , \quad (310)$$

one finds that an observer at the horizon would have zero proper time. In other words, at the horizon one has infinite redshift. Everything happening there goes on infinitely slowly for a far away observer. More clearly, for a faraway observer nothing at all happens at the horizon.

Ref. 89

Since black holes curve space-time strongly, a body moving near a black hole behaves in more complicated ways than in the case of universal gravity. In universal gravity, paths are either ellipses, parabolas, or hyperbolas; all these are plane curves. It turns out that paths lie in a plane only near *nonrotating* black holes.** Around such black holes, circular paths are impossible for radii less than $3R_S/2$ (can you show why?) and are unstable to perturbations

Challenge 775

* Robert Oppenheimer (1904–1967), important US-American physicist. He worked on quantum theory and atomic physics. He then headed the development of the nuclear bomb during the second world war. He is also famous for being the most prominent as well as innocent victim of one of the greatest witch-hunts that were organized in his home country.

** For such paths, Kepler’s rule connecting the average distance and the time of orbit

$$\frac{GMt^3}{(2\pi)^2} = r^3 \quad (311)$$

Challenge 758

still holds, provided the proper time and the radius measured by a far away observer is used.

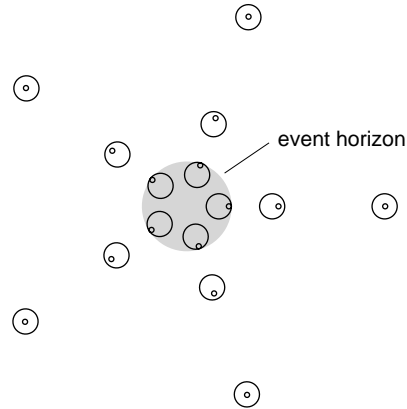

Figure 135 The light cones in the equatorial plane around a non-rotating black hole, seen from above

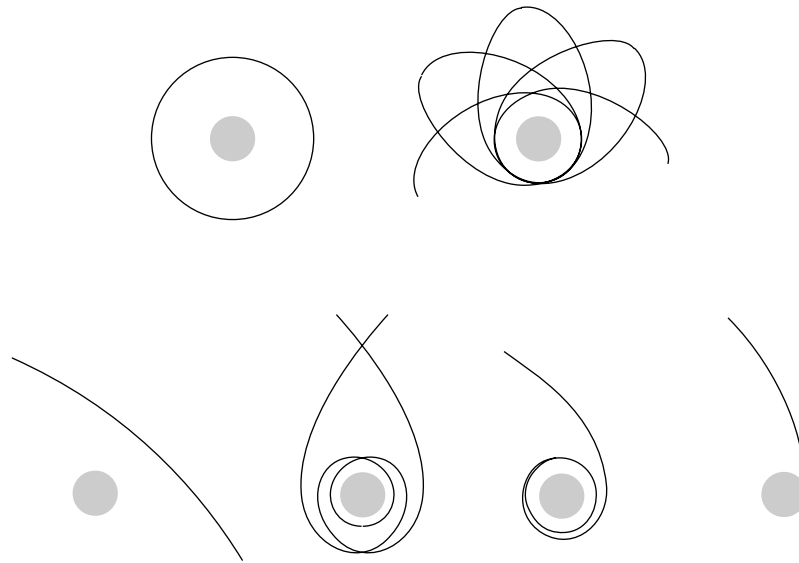

Figure 136 Motion of uncharged objects around a nonrotating black hole

from there up to a radius $3R_S$. Only at larger radii circular orbits are stable. Around black holes, there are no elliptic paths; the corresponding rosetta path is shown in Figure 136. Such a path shows the famous periastron shift in all its glory.

One detail deserves to be mentioned. If a cloud of dust falls into a black hole, the size of the cloud increases when falling into it, until the cloud envelops the whole horizon. In fact, the result is valid for any extended body. This property of black holes will be of importance later on, when we will discuss the size of elementary particles.

Note that the potential around a black hole is not appreciably different from $1/r$ for distances above about fifteen Schwarzschild radii. For a black hole of the mass of the sun, that would be 42 km from its centre; at the distance of the earth, we would not be able to note any difference for the path of the earth around the sun.

Challenge 792

For falling bodies coming from infinity, the situation near black holes is even more interesting. Of course there are no hyperbolic paths, only trajectories similar to hyperbolas for bodies passing far enough. But for small, but not too small impact parameters, a body will make a number of turns around the black hole, before leaving again. The number of turns increases beyond all bounds with decreasing impact parameter, until a value is reached at which the body is captured into an orbit at a radius of $2R$, as shown in Figure 136. In other words, this orbit captures incoming bodies if they reach it below a certain critical angle. For comparison, remember that in universal gravity, no capture exists. At still smaller impact parameters, the black hole swallows the incoming mass. In both cases, capture and deflection, a body can make several turns around the black hole, whereas in universal gravity, it is impossible to make more than *half* a turn around a body.

The most absurd looking orbits though are those (purely academic) orbits corresponding to the parabolic case of universal gravity. Relativity changes the motions due to gravity quite drastically.

Challenge 809

Around *rotating* black holes, the orbits of point masses are even more complex than those shown in Figure 136; for bound motion for example, the ellipses do not stay in one plane, but also change – due to the Thirring-Lense effect – the plane in which they lie, leading to extremely involved orbits in three dimensions filling the space around the black hole.

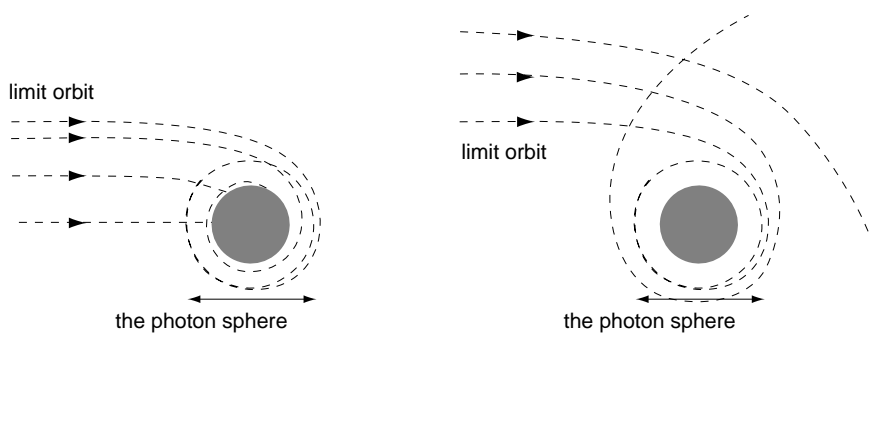

Figure 137 Motion of *light* passing near a non-rotating black hole

For *light* passing a black hole, the paths are equally interesting, as shown in Figure 137. there are only few differences with the case of rapid particles. For a non-rotating black hole, the path obviously lies in a single plane. Of course, there is strong bending of light, as well as capture, if light passes sufficiently nearby. Again, light can also make one or several turns around the black hole before leaving or being captured. The limit between the two cases is the path in which light moves in a circle around a black hole, at $3R/2$! However, this orbit

Challenge 826

is unstable. If one would be located on that orbit, one would see the back of one's head by looking forward! The set of all those orbits is called the *photon sphere*. It thus divides paths leading to capture from those leading to infinity. As a note, there is no *stable* orbit for light around a black hole at all. Are there any rosetta paths for light around a black hole?

Challenge 843

Around a *rotating* black hole, paths are much more complex. Already in the equatorial plane there are two possible circular light paths, namely a smaller one in direction of the rotation, and a larger one in the opposite direction.

Challenge 860

For *charged* black holes, the orbits for falling charged particles are even more complex. One has to study the electrical field lines; several fascinating effects appear with no correspondence in usual electromagnetism, such as effects similar to electrical versions of the Meissner effect. The whole field is still mostly unexplored and is one of today's research themes in general relativity.

But this is enough about orbits. Let us continue with another topic.

Hair and entropy

How is a black hole characterized? It turns out that black holes have no choice for their size, their shape, their colour, their magnetic field and all their material properties to be discussed later on. They all follow from the few properties characterizing them, namely their mass M ,

their angular momentum J , and their electrical charge Q .^{*} All other properties are uniquely determined by them.^{**} It is as though one could deduce every characteristic of a woman only by her size, her waist, and her height, following Wheeler's colourful language. Physicist also say that black holes 'have no hair,' meaning that (classical) black holes have no other degrees of freedom. Also this expression was introduced by Wheeler.^{***} This was shown by Israel, Carter, Robinson and Mazur; they showed that for a black hole with given mass, angular momentum and charges, there is only *one* possible black hole. (The uniqueness theorem is not valid any more if the black holes carries nuclear quantum numbers, such as weak or strong charges.)

Ref. 103

Ref. 104

In other words, independently of how the black holes has formed, independently of which material and composition was used when building it, the final result does not depend on those details. Black holes all have identical composition, or better, they have no composition at all (at least classically). More about this topic shortly.

The mass of a black hole is not restricted by general relativity. It may be as small as that of a microscopic particle, and as large as many million solar masses. But for their angular momentum J and for their electric charge Q the situation is different. A rotating black hole has a maximum possible angular momentum and a maximum possible electrical (and magnetic) charge.^{****} The limit in angular momentum appears as its perimeter may not move faster than light. Also for the charge there is a limit. The two limits are not independent as they are related by

Challenge 877

$$\left(\frac{J}{cM}\right)^2 + \frac{GQ^2}{4\pi\epsilon_0 c^4} \leq \left(\frac{GM}{c^2}\right)^2 \quad (312)$$

Black holes realizing the limit fast are called *extremal* black holes. The limit (312) simply follows from the limit on length to mass ratios at the basis of general relativity; the limit also implies that the horizon radius of a general black hole is given by

Challenge 894

$$r_h = \frac{GM}{c^2} \left(1 + \sqrt{1 - \frac{J^2 c^2}{M^4 G^2} - \frac{Q^2}{4\pi\epsilon_0 GM^2}} \right) \quad (313)$$

For example, for a black hole with the mass and angular momentum of the sun, namely $2 \cdot 10^{30}$ kg and $0.9 \cdot 10^{42}$ kg m²/s, the charge limit is about ... C.

How does one distinguish rotating from non-rotating black holes? First of all by the *shape*. Non-rotating black holes must be spherical (any non-sphericity is radiated away as gravitational waves) and rotating black holes have a slightly flattened shape, uniquely deter-

Ref.

* There are other entities encountered so far with the same reduced number of characteristics: particles. More on this connection will be uncovered in the third part of our mountain ascent.

** Mainly for marketing reasons, neutral non-rotating and electrically neutral black holes are often called *Schwarzschild* black holes: uncharged and rotating ones are often called *Kerr* black holes, after Roy Kerr, who discovered the corresponding solution of Einstein's field equations in 1963. Electrically charged, but non-rotating black holes are also called *Reissner-Nordstrom black holes*, after the German H. Reissner and the Danish G. Nordström. The general case, charged and rotating, is often named after Kerr and Newman.

Ref. 100

Ref. 101

*** It is not a secret that Wheeler was inspired by a clear anatomical image when he stated that 'black holes, in contrast to their surroundings, have no hair.'

**** More about the still hypothetical magnetic charge later on. It enters like an additional type of charge into all expressions in which electric charge appears.

mined by their angular momentum. Due to their rotation, their surface of infinite gravity or infinite redshift, called the *static limit*, is different from their horizon. The region in between, the *ergosphere*, as the name does not say, is *not* a sphere. (It is called this way because, as we will see shortly, it can be used to extract energy from the black hole.) The motion of bodies between the ergosphere and the horizon can be quite complex. It suffices to mention that rotating black holes drag any infalling body into an orbit around them, in contrast to nonrotating black holes, which swallow them. In other words, rotating black holes are not really ‘holes’ at all, but rather black vortices.

The distinction between rotating and non-rotating black holes also appears in the horizon surface area. The (horizon) surface of a non-rotating and uncharged black hole is obviously related to its mass by

Challenge 911

$$A = \frac{16\pi G^2}{c^4} M^2 \quad (314)$$

The surface-mass relation for a rotating and charged black hole is more complex; it is given by

$$A = \frac{8\pi G^2}{c^4} M^2 \left(1 + \sqrt{1 - \frac{J^2 c^2}{M^4 G^2} - \frac{Q^2}{4\pi\epsilon_0 G M^2}} \right) \quad (315)$$

where J is the angular momentum. In fact, the relation

$$A = \frac{8\pi G}{c^2} M r_h \quad (316)$$

is valid for *all* black holes, even if charged and rotating. Obviously, in the case of electrically charged black holes, the rotation also produces a magnetic field around them. This is in contrast with non-rotating black holes which cannot have a magnetic field.

Can one extract energy from a black hole? Roger Penrose discovered that this is possible for *rotating* black holes. A rocket orbiting a rotating black hole in its ergosphere could switch its engines on and then would get hurled into outer space at tremendous velocity, much greater than what the engines could have produced by themselves. In fact, the same effect is used by rockets on the earth as well and is the reason that all satellites orbit the earth in the same direction; it would cost much more fuel to let them turn the other way. * Anyway, the energy gained by the rocket is lost by the black hole, which thus slows down and would lose some mass; on the other hand, the mass increases due to the exhaust gases falling into the black hole. This increase always is larger or at best equal to the loss due to rotation slowdown. The best one can do is to turn the engines on exactly at the horizon; then the horizon area of the black hole stays constant, and only its rotation is slowed down. **

Ref. 105

Challenge 945

As a result, for a neutral black hole *rotating* with its maximum possible angular momentum, $1 - 1/\sqrt{2} = 29.3\%$ of its total energy can be extracted through the Penrose process.

Challenge 928

* And it would be much more dangerous, since any small object would hit such an against-the-stream satellite with about 15.8 km/s, thus transforming any small object into a dangerous projectile. In fact, any power wanting to destroy satellites of the enemy would simply have to load a satellites with nuts or bolts, send it into space the wrong way, and distribute the bolts into a cloud. It would make satellites impossible for many decades to come.

** It is also possible to extract energy from rotational black holes through gravitational radiation.

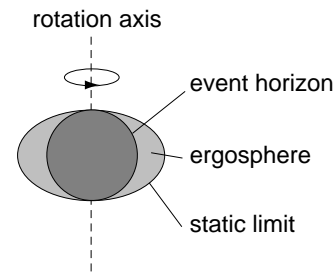

Figure 138 The ergosphere of a rotating black hole

For black holes rotating more slowly, the percentage is obviously smaller.

For *charged* black holes, such irreversible energy extraction processes are also possible. Can you think of a way? Inserting value (312), one finds that up to 50% of the mass of a non-rotating black hole can be due to its charge. In fact, in the second part of the mountain ascent we will encounter a process which nature seems to use quite frequently.

Challenge 962

Challenge 979

See page 595

The Penrose process allows to determine how angular momentum and charges increase the mass of a black hole. The result is the famous mass-energy relation

Ref. 106

$$M^2 = \frac{E^2}{c^4} = \left(m_{\text{irr}} + \frac{Q^2}{16\pi\epsilon_0 G m_{\text{irr}}}\right)^2 + \frac{J^2}{4m_{\text{irr}}^2} \frac{c^2}{G^2} = \left(m_{\text{irr}} + \frac{Q^2}{8\pi\epsilon_0 \rho_{\text{irr}}}\right)^2 + \frac{J^2}{\rho_{\text{irr}}^2} \frac{1}{c^2} \quad (317)$$

which shows how the electrostatic and the rotational energy enter the mass of a black hole. In the expression, m_{irr} is the *irreducible mass* defined as

$$m_{\text{irr}}^2 = \frac{A(M, 0, 0)}{16\pi} \frac{c^4}{G^2} = \left(\rho_{\text{irr}} \frac{c^2}{2G}\right)^2 \quad (318)$$

and ρ_{irr} is the *irreducible radius*.

These investigations showed that there is no process which *decreases* the horizon area and thus the irreducible mass or radius of the black hole. People have checked this in all ways possible and imaginable. For example, when two black holes merge, the total area increases. One calls processes which keep the area and energy of the black whole constant *reversible*, and all others irreversible. In fact, the area of black holes behaves like the *entropy* of a closed system: it never decreases. That the area in fact *is* an entropy was first stated in 1970 by Jakob Bekenstein. He deduced that only when an entropy is ascribed to a black hole, it was possible to understand where the entropy of all the material falling into it was collected.

Ref. 107

Again, the value of the entropy is a function only of the mass, the angular momentum and the charge of a black hole. You might want to confirm Bekenstein's deduction that the entropy is proportional to the horizon area. Later it was found, using quantum theory, that

Challenge 996

$$S = \frac{A}{4} \frac{kc^3}{\hbar G} = \frac{Ak}{4l_{\text{pl}}^2} \quad (319)$$

This famous relation needs quantum theory for its deduction, as the absolute value of entropy is never fixed by classical physics alone. We will discuss it later on in our mountain ascent.

See page 596

If black holes have an entropy, they also must have a temperature. If they have a temperature, they must shine. Black holes thus cannot be black! The last conclusion was proven by Stephen Hawking in 1974 with extremely involved calculations. However, it could have been deduced already in the 1930s, with a simple Gedankenexperiment that we will present later on. You might want to think about the issue, asking and investigating what strange consequences would appear if black holes had no entropy. Black hole radiation is a further, though tiny (quantum) mechanism for energy extraction, and is applicable even for non-rotating, uncharged black holes. The interesting connections between black holes, thermodynamics, and quantum theory will be presented in the second part of our mountain ascent. Can you imagine other mechanisms that make black hole shine?

See page 593

Challenge 1013

Paradoxes, curiosities, and challenges

Tiens, les trous noirs. C'est troublant.*
Anonyme

Black holes show many counterintuitive results.**

- Following universal gravity, a black hole would allow light to climb up, but it then would fall back down. In general relativity, a black hole does not allow light to climb up at all; it can only fall.

- What happens to a person falling into a black hole? An outside observer gives a clear answer: the falling person *never* arrives there since it needs an infinite time to reach the horizon. Can you confirm this result? The falling observer however, reaches the horizon in a *finite* amount of his own time. (Can you calculate it?)

Challenge 1030

Challenge 1047

This is surprising, as it means that for an outside observer in a universe with *finite* age, black holes cannot have formed yet! At best, one can only observe systems busy forming one. In a sense, it is thus correct to say that black holes do not exist. There is only one way out: black holes could have existed right from the start in the fabric of space-time. We will find out later why this is impossible. In other words, it is important to keep in mind that the idea of black hole is an *approximation*.

Independently of this last issue, we can confirm that in nature, the length to mass ratio always follows

$$\frac{L}{M} \geq \frac{4G}{c^2} . \quad (320)$$

- Interestingly, the *size* of a person falling into a black hole is also experienced in vastly different ways by the falling person and the one staying outside. If the black hole is large, the infalling observer feels almost nothing, as the tidal effects are small. The outside observer makes a startling observation: he sees the falling person *spread* all over the horizon of the black hole. *Infalling, extended bodies cover the whole horizon*. Can you explain the result, e.g. by using the limit on length to mass ratios?

Challenge 1064

This strange result will be of importance later on in our walk, and lead to important conclusions on the size of point particles.

- An observer near a (non-rotating) black hole, or in fact near any object smaller than 7/4 times its gravitational radius, can even see the complete *back* side of the object, as shown in Figure 139. Can you imagine how the image looks? Note that in addition to the paths shown in Figure 139, light can also turn several times around the black hole before hitting its surface! Therefore, such an observer sees an infinite number of images of the black hole. The formula for the angular size of the innermost image was given above.

Challenge 1081

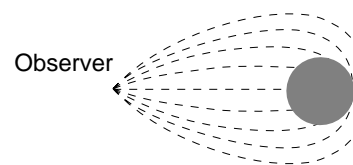

Figure 139 Motion of some light rays from a dense body to an observer

See page 249

* No translation possible.

** Other paradoxes which include quantum effects are discussed on page 599.

In fact, gravity has the effect to allow the observation of more than half a sphere of *any* object. In everyday life the effect is not so large, however; for example, light bending allows to see about 50.0002% of the surface of the sun.

- A mass point inside the smallest circular path of light around a black hole, at $3R/2$, cannot stay in a circle, because in that region, something strange happens. A body who circles another in everyday life always feels a tendency to be pushed outwards; this centrifugal effect is due to the inertia of the body. But at values below $3R/2$, a circulating body is pushed *inwards* by its inertia. There are several ways to explain this paradoxical effect. The simplest is to note that near a black hole, the weight increases faster than the centrifugal force, as you may want to check yourself. Only a rocket with engines switched on and pushing towards the sky can orbit a black hole at $3R/2$.

Ref. 108

Challenge 1098

- By the way, how can gravity or an electrical field come out of a black hole, if no signal and no energy can leave it?

Challenge 1115

- Do *white holes* exist, i.e. time inverted black holes, in which everything flows out of instead of into some bounded region?

Challenge 11

- In quantum theory, the *gyromagnetic ratio* is an important quantity for any rotating charged system. What is the gyromagnetic ratio for rotating black holes?

Challenge 28

- Do moving black holes Lorentz-contract? Black holes do shine a little bit; it is true that the images they form are complex, as the light can turn around them a few times, before reaching the observer. In addition, the observer has to be far away, so that curvature has small effects. All these effects can be taken into account; nevertheless, the question becomes subtle. The reason is that the concept of Lorentz contraction makes no sense in general relativity, as the comparison with the uncontracted situation is difficult to define precisely.

Challenge 45

Formation of and search for black holes

How might black holes form? At present, at least three mechanisms are distinguished; the question is still a hot subject of research. First of all, black holes could have formed during the early stages of the universe. These *primordial black holes* might grow through *accretion*, i.e. through the swallowing of nearby matter and radiation, or disappear through one of the mechanisms to be studied later on.

Ref. 109

See page 594

Of the *observed* black holes, the so-called *supermassive* black holes are found at the centre of every galaxy studied so far. They have masses in the range from 10^6 to 10^9 solar masses. They are conjectured to exist at the centre of all galaxies and seem to be related to the formation of galaxies themselves. Supermassive black holes are supposed to have formed through the collapse of large dust collections, and to have grown through subsequent accretion of matter. The latest ideas imply that these black holes accrete a lot of matter in their early stage; the matter falling in emits lots of radiation, and thus would explain the brightness of quasars. Later on, the accretion calms down, and one gets the less spectacular Seyfert galaxies. Still later, these supermassive black holes almost get dormant, like the one in the centre of our own galaxy.

On the other hand, black holes can form when old massive stars *collapse*. It is estimated that when stars with at least three solar masses burn out their fuel, the matter will collapse into a black holes. Such *stellar* black holes have a mass between one and a hundred so-

Ref. 110

lar masses; they can also continue growing through subsequent accretion. This situation provided the first candidate ever, Cygnus X-1, which was discovered in 1971.

Recent measurements suggest also the existence of *intermediate* black holes, with masses around thousand solar masses or more; their formation mechanisms and formation conditions are still unknown.

The search for black holes is a popular sport among astrophysicists. The conceptually simplest way to search for them is to look for strong gravitational fields. But only double stars allow to measure fields directly, and the strongest ever measured gravitational field so far is 30% of the theoretical maximum value.

Ref. 111

Another way is to look for strong gravitational lenses, and try to get a mass to size ratio pointing to a black hole.

Still another way is to look at the dynamics of stars near the centre of galaxies. Measuring their motion, one can deduce the mass of the body they orbit.

Ref. 112

The most favourite method is to look for extremely intense X-ray emission from point sources through space-based satellites or balloon based detectors. If the distance to the object is known, its absolute brightness can be deduced; if it is above a certain limit, it must be a black hole, since normal matter cannot produce an unlimited amount of light. The method is being perfected recently, with the aim to achieve the direct observation of energy disappearing into a horizon. This might have been observed recently.

Ref. 96

To sum up the experimental situation, measurements show that in all galaxies studied so far – more than a dozen – a supermassive black hole seems to be located at their centre. The masses vary; the black hole at the centre of our own galaxy has about 2.6 million solar masses. The central black hole of the galaxy M87 has 3 thousand million solar masses.

Ref. 96

About a dozen stellar black holes between 4 and 20 solar masses are known in the rest of our own galaxy, all discovered in the years after 1971, when Cygnus X-1 was found. In the year 2000, a couple of intermediate mass black holes have also been found. This list of discoveries, as well as the related results, are expected to expand dramatically in the coming years.

Singularities

Ref. 113

Solving the equations of general relativity, one finds that for many classes of initial conditions, a cloud of dust collapses to a *singularity*, i.e. to a point of infinite density. The same conclusion appears when one follows the evolution of the universe backwards in time. In fact, Roger Penrose and Stephen Hawking have proven several mathematical theorems on the necessity of singularities for many classical matter distributions. These theorems assume only the continuity of space-time and a few rather weak conditions on the matter in it. The theorems state that in expanding systems such as probably the universe itself, or in collapsing systems such as black holes in formation, events with infinite matter density should exist somewhere in the past, respectively in the future.

Challenge 62

Researchers distinguish two types of singularities: with and without an horizon. The latter ones, the so-called *naked* singularities, are especially strange; for example, a tooth brush can fall into a singularity and disappear without leaving any trace. Since the field equations are time invariant, one can thus expect that every now and then, naked singularities emit tooth brushes. (Can you explain why dressed singularities are less dangerous?)

Of course, naked singularities violate the limit on the size of physical systems, and could thus be dismissed as academic. Nevertheless, many people have tried to discover some theoretical principles forbidding the existence of naked singularities. It turns out that there is such a principle, and it is called *quantum theory*.* In fact, whenever one encounters a prediction of an infinite value, one has extended a description to a domain for which it was not conceived. In this case the applicability of pure general relativity to very small distances and very high energies has been assumed. As will become clear in the next two parts of the book, nature does not allow this; quantum theory shows that it makes no sense to talk about ‘singularities’ nor about what happens ‘inside’ a black hole horizon, as time and space are not continuous at smallest distances.**

See page 711

A quiz: is the universe a black hole?

Could it be that we live inside a black hole? Both the universe and black holes have horizons. Even more interesting, the horizon distance r_o of the universe is about

$$r_o \approx 3ct_o \approx 4 \cdot 10^{26} \text{ m} \quad (321)$$

and its matter content is about

$$m_o \approx \frac{4\pi}{3} \rho_o r_o^3 \quad \text{whence} \quad \frac{2Gm_o}{c^2} = 72\pi G \rho_o c t_o^3 = 6 \cdot 10^{26} \text{ m} \quad (322)$$

for a density of $3 \cdot 10^{-27} \text{ kg/m}^3$. Thus one has

$$r_o \approx \frac{2Gm_o}{c^2} \quad (323)$$

similar to the black hole relation $r_s = 2Gm/c^2$. Is this a coincidence? No, it is not; all systems with high curvature more or less obey the relation. But are we nevertheless falling into a large black hole? A detailed study will tell you.

Challenge 79

Challenge 96

12. General relativity in ten points – a summary for the layman

Sapientia felicitas.***

General relativity is the final description of *paths of motion*, or if one prefers, of the *macroscopic motion*. It describes how the observations of motion of *any* two observers are related to each other, and also describes motion due to gravity. In fact, general relativity is based on the following observations:

- All observers agree that there is a ‘perfect’ velocity in nature, namely a common maximum energy velocity relative to matter. The preferred velocity is realized by massless radiation, such as light or radio signals.

* There are also attempts to formulate such forbidding principles *inside* general relativity, called *cosmic censorship*, but we do not discuss them here.

Ref. 114

** Many physicists are still wary to make such strong statements at this point, especially all those who claim that space and time are continuous even down to the smallest distances. The part on quantum theory and the first sections of the third part of the mountain ascent give the precise arguments leading to the opposite conclusion.

See page 669

*** ‘Wisdom is happiness.’ It is also the motto of Oxford university.

- Any system of dimension L and mass M is bound by the limit

$$\frac{L}{M} \geq \frac{4G}{c^2} \quad (324)$$

which is realized only for black holes. From these two central facts one deduces:

- Space-time consists of events in $3 + 1$ *continuous dimensions*, with a curvature varying from point to point. The curvature can be deduced from distance measurements among events or from tidal effects. We thus live in a pseudo-riemannian space-time. Measured times, lengths, and curvatures vary from observer to observer.

- Space-time is *curved near mass and energy*. The average curvature at a point is determined by the energy-momentum density at that point and described by the field equations. When matter and energy move, the curvature moves along with them. A built-in delay renders faster than light transport of energy impossible. The proportionality constant between energy and curvature is so small that the curvature is not observed in everyday life, but only its indirect manifestation, namely gravity.

- Space is also *elastic*; it prefers being flat. Being elastic, it can wiggle also independently of matter; one then speaks of gravitational radiation or of gravity waves.

- Freely falling matter moves along *geodesics*, i.e. along paths of maximal length in curved space-time; in space this means that light bends when it passes near large masses by twice the amount predicted by universal gravity.

- To describe gravitation one *needs* curved space-time, i.e. general relativity, *at the latest* whenever distances are of the order of the Schwarzschild radius $r_S = 2Gm/c^2$. When distances are much larger, the description by universal gravity, namely $a = Gm/r^2$, together with flat Minkowski space-time, will do as approximation.

- Space and time are not distinguished globally, but only locally. *Matter* is required to perform the distinction.

In addition, all matter and energy we observe in the sky provide two observations:

- The universe has a *finite age*; it is the reason for the darkness at night. A horizon limits the measurable space-time intervals to about twelve thousand million years.

- On cosmological scale, everything moves away from everything else: the universe is *expanding*. This expansion of space-time is also described by the field equations.

The accuracy of the description

Was general relativity worth the effort? The discussion of its accuracy is most conveniently split into two sets of experiments. The first set is given by measurements of how *matter moves*. Do objects really follow geodesics? So far, all experiments agree with theory within measurement errors, i.e. at least within 1 part in 10^{12} . In short, the way matter falls is indeed described by general relativity in all details.

The second set consists of measurements of the dynamics of space-time itself. Does *space-time move* following the field equations of general relativity? In other words, is space-time really bent by matter in the way the theory predicts? Many experiments have been performed, some near and most far from earth, both in weak and in strong fields. All agree with the predictions within errors. However, the best measurements so far have only about 3 significant digits. Note that even though numerous experiments have been performed, there

Ref. 115, 116

Measured effect	confirmation	type	reference
equivalence principle	10^{-12}	motion of matter	Ref. 13, 115
$1/r^2$ dependence (dimensionality of space-time)	10^{-10}	motion of matter	Ref. 117
time independence of G	10^{-19} /s	motion of matter	Ref. 115
redshift (light & microwaves on sun, earth, Sirius)	10^{-4}	space-time curvature	Ref. 9, 21, 115
perihelion shift (four planets, Icarus, pulsars)	10^{-3}	space-time curvature	Ref. 115
light deflection (light, radio waves around sun, stars, galaxies)	10^{-3}	space-time curvature	Ref. 115
time delay (radio signals near sun, near pulsars)	10^{-3}	space-time curvature	Ref. 115
gravitomagnetism (earth, pulsar)	10^{-1}	space-time curvature	Ref. 35
geodesic effect (moon, pulsars)	10^{-1}	space-time curvature	Ref. 49, 115
gravity wave emission delay (pulsars)	10^{-3}	space-time curvature	Ref. 115

Table 29 Present types of tests of general relativity

are only few *types* of tests, as Table 29 shows; in the past, discovering a new type has always meant fame and riches. Most sought after, of course, is the direct detection of gravitational waves.

Challenge 113

Another comment of the table is in order. After many decades in which all measured effects were only of order v^2/c^2 , several so-called *strong field effects* in pulsars allowed to reach v^4/c^4 effects. Soon a few effects of this order should also be detected even inside the solar system, using high-precision satellite experiments. The present crown of all measurements, the gravity wave emission delay, is the only v^5/c^5 effect measured so far.

Ref. 115

See page 258

The difficulty to achieve high precision for space-time curvature measurements is the reason that mass is measured with balances, always (indirectly) using the prototype kilogram in Paris, instead of defining some standard curvature and fixing the value of G . Indeed, no terrestrial curvature experiment has ever been carried out. Also in this domain a breakthrough would make the news. At present, any terrestrial curvature method would not even allow to define a kilogram of gold or of oranges with a precision of a single kilogram!

Another possible check of general relativity is the search for alternative descriptions of gravitation. Quite a number of competing theories of gravity have been formulated and studied, but none is in agreement with all experiments.

Ref. 116, 118

In summary, as Thibault Damour likes to say, general relativity is at least 99.999 999 999 9% correct concerning the motion of matter and energy, and at least 99.9% correct about the way matter and energy curve and move space-time. No exceptions, no anti-gravity, and no unclear experimental data are known. All macroscopic motion, on earth and in the skies, is described by general relativity. In this context, *macroscopic motion* is any example of motion for which the action is much larger than 10^{-34} Js. The importance of the achievement of Albert Einstein cannot be understated.

Ref. 115

Research in general relativity and cosmology

Despite all these successes, research in general relativity is more intense than ever.*

Ref. 120

- The description of collisions and of many body problems, as in the motion of stars, neutron stars, and black holes, with its richness of behaviour, helps astrophysicists to improve their understanding of signals they observe in their telescopes.

Ref. 121

- The study of the early universe and of elementary particle properties, with topics such as *inflation*, a short period of accelerated expansion during the first few seconds, is still an important topic of investigation.

Ref. 123

- The study of chaos in the field equations is of fundamental interest in the study of the early universe, and may be related to the problem of galaxy formation, one of the biggest open problems in physics.

Ref. 122

- The determination of the cosmological parameters, such as the matter density, the curvature, and the vacuum density, is a central effort of modern astrophysics.

Ref. 60

- Astrophysicists regularly discover new phenomena in the skies. For example, despite what will be said later, gamma ray bursts are still not completely understood. The longest and most energetic so far, several hours long with photons of 25 GeV energy, was observed in February 1994.

See page 595

Ref. 124

- A computer database of all solutions of the field equations is being built. Among others, researchers are checking whether they really are all different from each other.

Ref. 125

- The inclusion of torsion into field equations, a possible extension of the theory, is one of the promising attempts to include particle spin into general relativity.

Ref. 126

- Studying solutions with nontrivial topology, such as wormholes and particle-like solutions, is a fascinating field of enquiry, also related to string theory.

Ref. 127

- Other formulations of general relativity, describing space-time with quantities other than the metric, are continuously developed, in the hope to clarify the relation to the quantum world. In fact, the unification of quantum physics and general relativity, the topic of the third part of this mountain ascent, will occupy researchers for many years to come.

Ref. 128

- Finally, the teaching of general relativity, which for many decades has been hidden behind Greek indices, differential forms and other antididactic methods, will benefit greatly from future improvements focusing on the physics, and less on the formalism.

Ref. 129

In short, general relativity is still an extremely interesting field of research, and important discoveries are still expected.

The limits of general relativity

Even though successful, the description of motion presented so far is unsatisfactory; maybe you already have some stomach feeling about certain unresolved issues. First of all, even though the speed of light is the starting point of the whole theory, we still do not know what light actually *is*. Finding out will be the next topic.

Challenge 130

Secondly, we saw that everything falls along geodesics. But a mountain does not fall. Somehow the matter below prevents it from falling. How does it achieve this? And where does mass come from anyway? What is mass? General relativity does not provide an answer;

* There is even a free and excellent internet based research journal, called *Living Reviews in Relativity*, to be found at the <http://www.livingreviews.org> web site.

in fact, it does not describe matter *at all*. Einstein used to say that the left-hand side of the field equations, describing the curvature of space-time, was granite, the right-hand side, describing matter, was sand. Indeed, at this point we still do not know what mass is. As already remarked, to change the sand into rock one first needs quantum theory and then, in a further step, its unification with relativity. This is also the program for the rest of our adventure.

We also saw that matter is necessary to clearly distinguish space and time, and in particular, to understand the working of clocks, meter bars, and balances. In particular, one question remains: why are there units of mass, length and time in nature *at all*? This deep question will also be addressed in the rest of our mountain ascent.

Additionally, we found that we do not know enough about the vacuum. We need to understand the magnitude of the cosmological constant and the number of space-time dimensions to answer the simple question: Why the sky is so far away? General relativity does not help here. Worse, the smallness of the cosmological constant contradicts the simplest version of quantum theory, and is one of the reasons why we still have quite some height to escalate before we reach the top of motion mountain.

See page 669

In short, to describe motion well, we realize that we need a more precise description of light, of matter, and of the vacuum! Otherwise we cannot hope to answer questions about mountains, clocks and stars. In a sense, it seems that we achieved quite little. Worse, for the following topic we are forced to go backwards, to situations *without* gravity, i.e. back to the framework of special relativity. That is the next, middle section of our mountain ascent. Despite the simplification, a lot of fun is waiting there.

See page 570

It's a good thing we have gravity, or else when birds died
they'd just stay right up there. Hunters would be all confused.
Steven Wright, comedian.



References

- 1 ALBERT EINSTEIN, Sitzungsberichte der Preussischen Akademie der Wissenschaften II pp. 844–846, 1915, is a the first explanation of the general theory of relativity, in only three pages. The theory is then explained in detail in the famous article ALBERT EINSTEIN, *Die Grundlage der allgemeinen Relativitätstheorie*, Annalen der Physik **49**, pp. 769–822, 1916.

A selection of English language textbooks for deeper study should include, in ascending order of depth and difficulty:

- Almost no formulas, but loads of insight are found in the enthusiastic text by JOHN A. WHEELER, *A journey into gravity and space-time*, 1990.
- Beauty, simplicity and shortness is the characteristic of MALCOLM LUDVIGSEN, *General relativity, a geometric approach*, Cambridge University Press, 1999.
- A good overview of experiments and theory is given in JAMES FOSTER & J.D. NIGHTINGALE, *A short course in general relativity*, Springer Verlag, 2nd edition 1998.
- A pretty text is SAM LILLEY, *Discovering relativity for yourself*, Cambridge University

- Press, 1981.
- A modern text is by RAY D'INVERNO, *Introducing Einstein's relativity*, Clarendon Press, 1992. It includes an extended description of black holes and gravitational radiation, and regularly refers to present research.
 - A beautiful, informative, and highly recommended text is HANS C. OHANIAN & REMO RUFFINI, *Gravitation and Spacetime*, W.W. Norton & Co., 1994.
 - A well written and modern book, with emphasis on the theory, by one of the masters of the field is WOLFGANG RINDLER, *Relativity – special, general, and cosmological*, 2001.
 - A classic is STEVEN WEINBERG, *Gravitation and Cosmology*, Wiley, 1972.
 - The mightiest text will remain the one by CHARLES MISNER, KIP THORNE & JOHN A. WHEELER, *Gravitation*, Freeman, 1973.
 - The toughest and most professional text is ROBERT M. WALD, *General relativity*, University of Chicago Press, 1984.
- In other languages, see the next reference. Cited on page 233, 260, 261.
- 2** A beautiful German teaching text is the classic G. FALK & W. RUPPEL, *Mechanik, Relativität, Gravitation – ein Lehrbuch*, Springer Verlag, Dritte Auflage, 1983.
- A practical and elegant booklet is ULRICH E. SCHRÖDER, *Gravitation – Einführung in die allgemeine Relativitätstheorie*, Verlag Harri Deutsch, Frankfurt am Main, 2001.
- A modern reference is TORSTEN FLIESSBACH, *Allgemeine Relativitätstheorie*, Akademischer Spektrum Verlag, 1998.
- Excellent is HUBERT GOENNER, *Einführung in die spezielle und allgemeine Relativitätstheorie*, Akademischer Spektrum Verlag, 1996.
- In Italian, there is the beautiful, informative, but expensive HANS C. OHANIAN & REMO RUFFINI, *Gravitazione e spazio-tempo*, Zanichelli, 1997. It is highly recommended. Cited on page 233, 257, 257, 258, 260, 261.
- 3** P. MOHAZZABI & J.H. SHEA, *High altitude free fall*, American Journal of Physics **64**, pp. 1242–1246, 1996. As a note, due to a technical failure Kittinger had his hand in (near) vacuum during his ascent, without incurring any permanent damage. See the <http://www.sff.net/people/geoffrey.landis/vacuum.html> web site. Cited on page 233.
- 4** A good source for images of space-time is the text by G.F.R. ELLIS & R. WILLIAMS, *Flat and curved space-times*, Clarendon Press, Oxford, 1988. Cited on page 240.
- 5** The expeditions had gone to two small islands, namely to Sobral, north of Brazil, and to Principe, in the gulf of Guinea. The results of the expedition appeared in the Times newspaper *before* they appeared in a scientific journal. Today this would be seen as a gross violation of scientific honesty. The results were published as F.W. DYSON, A.S. EDDINGTON & C. DAVIDSON, Philosophical Transactions of the Royal Society (London) **220A**, p. 291, 1920, and Memoirs of the Royal Astronomical Society **62**, p. 291, 1920. Cited on page 239.
- 6** More information about tides can be found in E.P. CLANCY, *The tides*, Doubleday, New York, 1969. Cited on page 238.
- 7** The speed of light has been measured for observers with emitters which were accelerated and moving with over 99.9% of the speed of light. This is observed in synchrotrons and in star explosions. See ... Cited on page 242.
- 8** H. BONDI, *Gravitation*, European Journal of Physics **14**, pp. 1–6, 1993. Cited on page 235.
- 9** R.V. POUND & G.A. REBKA, The famous paper is *Apparent weight of photons*, Physical Review Letters **4**, pp. 337–341, 1960. A higher precision version was published by R.V. POUND & J.L. SNIDER, Physical Review Letters **13**, p. 539, 1964, and R.V. POUND & J.L. SNIDER, Physical Review B **140**, p. 788, 1965, Cited on page 236, 327.

- 10 J.C. HAFELE & RICHARD E. KEATING, *Around-the-world atomic clocks: predicted relativistic time gains*, *Science* **177**, pp. 166–167, and *Around-the-world atomic clocks: observed relativistic time gains*, pp. 168–170, 14 July 1972. Cited on page 236.
- 11 R.F.C. VESSOT & al., *Test of relativistic gravitation with a space-borne hydrogen maser*, *Physical Review Letters* **45**, pp. 2081–2084, 1980. The experiment was performed in 1976; there are more than a dozen coauthors involved in this work, which involved shooting a maser into space with a scout missile to a height of ca. 10 000 km. Cited on page 236.
- 12 L. BRIATORE & S. LESCHIUTTA, *Evidence for the earth gravitational shift by direct atomic-time-scale comparison*, *Il Nuovo Cimento* **37B**, pp. 219–231, 1977. Cited on page 236.
- 13 The equality was first tested with precision by ROLAND VON EÖTVÖS, *Annalen der Physik & Chemie* **59**, p. 354, 1896, and by R. VON EÖTVÖS, V. PEKÁR & E. FEKETE, *Beiträge zum Gesetz der Proportionalität von Trägheit und Gravität*, *Annalen der Physik* 4, Leipzig **68**, pp. 11–66, 1922. He found agreement to 5 parts in 10^9 . More experiments were performed by P.G. ROLL, R. KROTKOW & R.H. DICKE, *The equivalence of inertial and passive gravitational mass*, *Annals of Physics (NY)* **26**, pp. 442–517, 1964, one of the most interesting and entertaining research articles in experimental physics, and by V.B. BRAGINSKY & V.I. PANOV, *Soviet Physics - JETP* **34**, pp. 463–466, 1971. Modern results, with errors less than one part in 10^{12} , are by Y. SU & al., *New tests of the universality of free fall*, *Physical Review D* **50**, pp. 3614–3636, 1994. Several experiments have been proposed to test the equality in space to less than one part in 10^{16} . Cited on page 249, 327.
- 14 This story is told e.g. by W.G. UNRUH, *Time, gravity, and quantum mechanics*, gr-qc/9312027. Cited on page 234.
- 15 J. DROSTE, *Het veld van een enkel centrum in Einstein's theorie der zwaartekracht, en de beweging van een stoffelijk punt*, *Verslag gew. Vergad. Wiss. Amsterdam* **25**, pp. 163–180, 1916. Cited on page 241.
- 16 L.B. KREUZER, *Experimental measurement of the equivalence of active and passive gravitational mass*, *Physical Review* **169**, pp. 1007–1012, 1968. With a clever set-up, he showed that the gravitational mass of fluorine and of bromine are equal. Cited on page 241.
- 17 That bodies fall along geodesics has been checked by ... Cited on page 245.
- 18 So far, the experiments confirm that electrostatic and (strong) nuclear energy fall like matter to within one part in 10^8 , and weak (nuclear) energy to within a few percent. This is summarized in the reference 24. Cited on page 245.
- 19 J. SOLDNER, *Berliner Astronomisches Jahrbuch auf das Jahr 1804*, 1801, p. 161. Cited on page 246.
- 20 See the excellent explanation in N. DRAGON, *Geometrie der Relativitätstheorie*, downloadable from the <http://www.itp.uni-hannover.de/dragon> web site. Cited on page .
- 21 J.W. BRAULT, Princeton University PhD thesis, 1962. See also J.L. SNIDER, *Physical Review Letters* **28**, pp. 853–856, 1972, and for the star Sirius see J.L. GREENSTEIN & al., *Astrophysical Journal* **169**, p. 563, 1971. Cited on page 235, 327.
- 22 See for example K.D. OLUM, *Superluminal travel requires negative energies*, *Physical Review Letters* **81**, pp. 3567–3570, 1998. Cited on page 247.
- 23 See the *Astronomical Almanac*, and its *Explanatory supplement*, H.M. Printing Office, London and U.S. Government Printing Office, Washington. For the information about various time coordinates used in the world, such as barycentric coordinate time, the time at the barycentre of the solar system, see also the <http://tycho.usno.navy.mil/system.html> webpage. It also contains a good bibliography. Cited on page 248.
- 24 An overview is given in C. WILL, *Theory and Experiment in Gravitational Physics*, chapter 14.3, revised edition, Cambridge University Press, 1993. (Despite being a standard reference,

- the role of tides and the role of gravitational energy within the principle of equivalence, as discussed in the text, has also been criticized by other researchers.) See also C. WILL, *Was Einstein right? – Putting general relativity to the test*, Oxford University Press, 1993. See also his paper <http://arxiv.org/gr-qc/9811036>. Cited on page 248, 260, 331.
- 25 The calculation omits several smaller effects, such as rotation of the earth, redshift, and others. For the main effect, see EDWIN F. TAYLOR, ‘*The boundaries of nature: special and general relativity and quantum mechanics, a second course in physics*’ – *Edwin F. Taylor’s acceptance speech for the 1998 Oersted Medal presented by the American Association of Physics Teachers, 6 January 1998*, *American Journal of Physics* **66**, pp. 369–376, 1998. Cited on page 248.
- 26 A.G. LINDH, *Did Popper solve Hume’s problem?*, *Nature* **366**, pp. 105–106, 11 November 1993. Cited on page 248.
- 27 The measurement is presented in the *Astrophysical Journal*, in 1998 or 1999. Some beautiful graphics on the models of this star system can be found at the <http://www.physics.uiuc.edu/groups/tastro/movies/spm/> web site. Cited on page 249.
- 28 R.J. NEMIROFF, *American Journal of Physics* **61**, p. 619, 1993. Cited on page 249.
- 29 WOLFGANG RINDLER, *Essential relativity – special, general, and cosmological*, Revised second edition, Springer, 1977. Cited on page 264.
- 30 M. SANTANDER, L.M. NIETO & N.A. CORDERO, *A curvature based derivation of the Schwarzschild metric*, *American Journal of Physics* **65**, pp. 1200–1209, 1997. Cited on page 267, 268, 269.
- 31 R.P. FEYNMAN, *Lectures on gravitation*, ... Cited on page 268.
- 32 The equivalence of the various definitions of the Riemann tensor is explained in ... Cited on page 280.
- 33 Arguments for the emptiness of general covariance are given by JOHN D. NORTON, *General covariance and the foundations of general relativity*, *Reports on Progress in Physics* **56**, pp. 791–858, 1993. The opposite point, including the discussion of ‘absolute elements,’ is made in the book by ... ANDERSON, *Principles of relativity physics*, chapter 4, 1993. Cited on page 274.
- 34 The Thirring effect was predicted in H. THIRRING, *Physikalische Zeitschrift Über die Wirkung rotierender ferner Massen in der Einsteinschen Gravitationstheorie*, **19**, pp. 33–39, 1918, and also studied in H. THIRRING, *Physikalische Zeitschrift* **22**, p. 29, 1921. The Thirring-Lense effect was predicted in H. THIRRING & J. LENSE, *Über den Einfluß der Eigenrotation der Zentralkörper auf die Bewegung der Planeten und Monde nach der Einsteinschen Gravitationstheorie*, *Physikalische Zeitschrift* **19**, pp. 156–163, 1918. See also reference 48. Cited on page 251.
- 35 The feat, using the LAGEOS and LAGEOS II satellites, is told in IGNAZIO CIUFOLINI, *The 1995-99 measurements of the Thirring-Lense effect using laser-ranged satellites*, *Classical and Quantum Gravity* **17**, pp. 2369–2380, 2000. Cited on page 251, 327.
- 36 The detection of Thirring-Lense effects in binary pulsars is presented in ... Cited on page 251.
- 37 D. BEDFORD & P. KRUMM, *On relativistic gravitation*, *American Journal of Physics* **53**, p. 889–890, 1985. P. KRUMM & D. BEDFORD, *The gravitational Poynting vector and energy transfer*, *American Journal of Physics* **55**, p. 362–363, 1987. Cited on page 253, 257.
- 38 JØRGEN KALCKAR & OLE ULFBECK, ... Cited on page 255.
- 39 See for example, K.T. MCDONALD, *Answer to question #49. Why c for gravitational waves?*, *American Journal of Physics* **65**, pp. 591–592, 1997, and section III of V.B. BRAGINSKY, C.M. CAVES & K.S. THORNE, *Laboratory experiments to test relativistic gravity*, *Physical Review D* **15**, pp. 2047–2068, 1992. Cited on page 255.

- 40 For an introduction to gravitational waves, see B.F. SCHUTZ, *American Journal of Physics* **52**, p. 412, 1997. Cited on page .
- 41 The beautiful summary by DANIEL KLEPPNER, *The gem of general relativity*, *Physics Today* pp. 9–11, April 1993, appeared half a year before the authors of the cited work, Joseph Taylor and Russel Hulse, received the Nobel prize for the discovery of millisecond pulsars. A more detailed review article is J.H. TAYLOR, *Pulsar timing and relativistic gravity*, *Philosophical Transactions of the Royal Society, London A* **341**, pp. 117–134, 1992. The original paper is J.H. TAYLOR, J.M. WEISBERG, *Further experimental tests of relativistic gravity using the binary pulsar PSR 1913+16*, *Astrophysical Journal* **345**, pp. 434–450, 1989. See also J.M. WEISBERG, J.H. TAYLOR & L.A. FOWLER, *Pulsar PSR 1913+16 sendet Gravitationswellen*, *Spektrum der Wissenschaft*, Dezember 1981. Cited on page 258, 258.
- 42 W.B. BONNOR & M.S. PIPER, *The gravitational wave rocket*, gr-qc/9702005. Cited on page 258.
- 43 L. LERNER, *A simple calculation of the deflection of light in a Schwarzschild gravitational field*, *American Journal of Physics* **65**, pp. 1194–1196, 1997. Cited on page 259.
- 44 A. EINSTEIN, *Annalen der Physik Über den Einfluß der Schwerkraft auf die Ausbreitung des Lichtes*, **35**, p. 898, 1911. Cited on page 260.
- 45 I.I. SHAPIRO, *Physical Review Letters* **13**, pp. 789–792, 1964. Cited on page 260.
- 46 I.I. SHAPIRO & al., *Physical Review Letters* **20**, pp. 1265–1268, 1968. Cited on page 260.
- 47 J.H. TAYLOR, *Pulsar timing and relativistic gravity*, *Proceedings of the Royal Society, London A* **341**, pp. 117–134, 1992. Cited on page 260.
- 48 W. DE SITTER, *On Einstein's theory of gravitation and its astronomical consequences*, *Monthly Notes of the Royal Astronomical Society* **77**, pp. 155–184, p. 418E, 1916. For a discussion of de Sitter precession and Thirring-Lense precession, see also B.R. HOLSTEIN, *Gyroscope precession in general relativity*, *American Journal of Physics* **69**, pp. 1248–1256, 2001. Cited on page 263, 332.
- 49 B. BERTOTTI, I. CIUFOLINI, P.L. BENDER, *Physical Review Letters* **58**, pp. 1062–1065, 1987. Later it was confirmed by I.I. SHAPIRO & al., *Measurement of the de Sitter precession of the moon: a relativistic three body effect*, *Physical Review Letters* **61**, pp. 2643–2646, 1988. Cited on page 263, 327.
- 50 This is told (without the riddle solution) on p. 67, in *W. Pauli, Relativitätstheorie*, Springer Verlag, Berlin, 2000, the edited reprint of a famous text originally published in 1921. The reference is H. VERMEIL, *Notiz über das mittlere Krümmungsmaß einer n-fach ausgedehnten Riemannschen Mannigfaltigkeit*, *Gött. Nachr., math.-phys. Kl.* p. 334, 1917. Cited on page 264.
- 51 See for example the paper by K. DALTON, *Gravity, Geometry, and Equivalence*, <http://xxx.lanl.gov/abs/gr-qc/9601004> and L. LANDAU & E. LIFSHITZ, *The Classical Theory of Fields*, Pergamon, 4th edition, 1975, p. 241. Cited on page 278.
- 52 A recent overview on the experimental tests of the universality of free fall is given by R.J. HUGHES, *The equivalence principle*, *Contemporary Physics* **4**, pp. 177–191, 1993. Cited on page 277.
- 53 JEAN-PAUL DUMONT, *Les écoles présocratiques*, *Folio Essais*, Gallimard, p. 61, 1991. Cited on page 287.
- 54 See for example A.N. COX, editor *Allen's Astrophysical Quantities*, AIP Press and Springer Verlag, 2000. Cited on page 283.
- 55 G. GAMOW, *Physical Review* **174**, p. 505, 1948. Cited on page 286.

- 56** A.G. DOROSHKOVICH & I.D. NOVIKOV, Dokl. Akad. Nauk. SSSR **154**, p. 809, 1964. It appeared translated into English a few months later. The story of the prediction was told by Penzias in his Nobel lecture. Cited on page [286](#).
- 57** ARNO A. PENZIAS & ROBER W. WILSON, Astrophysical Journal **142**, p. 419, 1965. Cited on page [286](#).
- 58** An opposite idea is defended by ... Cited on page [285](#).
- 59** A. FRIEDMANN, Zeitschrift für Physik **10**, p. 377, 1922, and Zeitschrift für Physik **21**, p. 326, 1924. Cited on page [290](#).
- 60** The experiments are discussed in detail in the excellent review by D. GIULINI & N. STRAUMANN, *Das Rätsel der kosmischen Vakuumenergiedichte und die beschleunigte Expansion des Universums*, Physikalische Blätter **556**, pp. 41–48, 2000. See also N. STRAUMANN, *The mystery of the cosmic vacuum energy density and the accelerated expansion of the universe*, European Journal of Physics **20**, pp. 419–427, 1999. Cited on page [295](#), [328](#).
- 61** Supernova searches are being performed by ... Cited on page [295](#).
- 62** Fred Hoyle still defends his idea that the universe is static, e.g. in ... Physics Today ... Cited on page [297](#), [297](#).
- 63** STEPHEN W. HAWKING & G.F.R. ELLIS, *The large scale structure of space-time*, Cambridge University Press, Cambridge, 1973. Among others, this reference text discusses the singularities of space-time, and their necessity in the history of the universe. Cited on page [298](#), [312](#), [337](#).
- 64** Augustine ... Cited on page [299](#).
- 65** S. HAWKING, *A brief history of time – From the big bang to black holes*, 1988. Cited on page [299](#).
- 66** This famous quote is the first sentence of the final chapter, the ‘Beschluß’, of IMMANUEL KANT, *Kritik der praktischen Vernunft*, 1797. Cited on page [281](#).
- 67** P. JETZER, *Gravitational microlensing*, Naturwissenschaften **86**, pp. 201–211, 1999. Cited on page [283](#).
- 68** Galaxy mass measurements are described by ... Cited on page [282](#).
- 69** G. BASRI, *The discovery of brown dwarfs*, Scientific American pp. 77–83, April 2001. Cited on page [284](#).
- 70** The author of the bible explains *rain* in this way, as can be deduced from its very first page, Genesis 1, 6-7. Cited on page [296](#).
- 71** H. KNUTSEN, *Darkness at night*, European Journal of Physics **18**, pp. 295–302, 1997. Cited on page [294](#), [294](#).
- 72** P. PESIC, *Brightness at night*, American Journal of Physics **66**, pp. 1013–1015, 1998. Cited on page [294](#), [295](#).
- 73** PAUL WESSON, ..., Astrophysical Journal **367**, p. 399, 1991. Cited on page [294](#).
- 74** STEVEN WEINBERG, *Gravitation and cosmology*, John Wiley, 1972. An excellent book written with a strong personal touch, and stressing most of all the relation with experimental data. It does not develop a strong feeling for space-time curvature, and does not address the basic problems of space and time in general relativity. Excellent for learning how to actually calculate things, but less for the aims of our mountain ascent. Cited on page [295](#), [310](#).
- 75** Star details are explained in many texts. See for example ... Cited on page [300](#).
- 76** JOHANNES PELT, ..., Astronomy and Astrophysics 1995. Cited on page [302](#).

77 F. ZWICKY, *Physical Review Letters* **51**, p. 290, and p. 679, 1937. The negative view by Einstein is found in A. EINSTEIN, *Science* **84**, p. 506, 1936.

A review on gravitational lensing can even be found online, in the paper by J. WAMBSGANSS, *Living Reviews in Relativity* **1-12**, pp. 1–80, 1998, to be found on the <http://www.livingreviews.org/Articles/Volume1/1998-12wamb/> web site.

There is also the book by P. SCHNEIDER, J. EHLERS & E.E. FALCO, *Gravitational lenses*, Springer Verlag, Berlin, 1992. Cited on page **302**.

78 M. LACHIÈZE-REY, J.-P. LUMINET, *Cosmic topology*, *Physics Reports* **254**, pp. 135–214, 1995. Cited on page **303**.

79 Thanks to Steve Carlip for clarifying this point. Cited on page **304**.

80 G.F.R. ELLIS, T. ROTHMANN, *Lost horizons*, *American Journal of Physics* **61**, pp. 883–893, 1993. Cited on page **304**.

81 Entropy values for the universe have been discussed by ILYA PRIGOGINE, ... For a different approach, see G.A. MENA MARUGÁN & S. CARNEIRO, *Holography and the large number hypothesis*, www.arxiv.org/gr-qc/0111034. It also gives the often heard statement that the universe has an entropy that is much smaller than the theoretical maximum. The maximum is ‘generally’ estimated to be $k 10^{120}$, whereas the actual value is ‘estimated’ to be $k 10^{100}$. However, other authors give $k 10^{84}$. Cited on page **305**.

Challenge 147

In 1974, Roger Penrose also made statements about the entropy of the universe.

82 C.L. BENNET, M.S. TURNER & M. WHITE, *The cosmic rosetta stone*, *Physics Today* **50**, pp. 32–38, November 1997. The cosmic background radiation differs from black hole radiation by less than 0.005%. Cited on page **306**.

83 The lack of expansion in the solar system is shown in ... Cited on page **307**.

84 A pretty article explaining how one can make experiments to find out how the human body senses rotation even when blindfolded and earphoned is described by M.-L. MITTELSTAEDT & H. MITTELSTAEDT, *The effect of centrifugal force on the perception of rotation about a vertical axis*, *Naturwissenschaften* **84**, pp. 366–369, 1997. Cited on page **307**.

85 The independence of inertia has been tested ... Cited on page **307**.

86 The present status is given in the conference proceedings by JULIAN BARBOUR & HERBERT PFISTER, (editors) *Mach’s principle: from Newton’s bucket to quantum gravity*, Birkhäuser, 1995. Various formulations of Mach’s principle – in fact, 21 different ones – are compared on page 530. Cited on page **307, 308**.

87 Information on the rotation of the universe is given in J.D. BARROW, R. JUSZKIEWICZ & D.H. SONODA, *Universal rotation: how large can it be?*, *Monthly Notices of the Royal Astronomical Society* **213**, pp. 917–943, 1985. See also J.D. BARROW, R. JUSZKIEWICZ & D.H. SONODA, *Structure of the cosmic microwave background*, *Nature* **309**, pp. 397–402, 1983, or E.F. BUNN, X. FERREIRA & X. SILK, *Physical Review Letters* **77**, pp. 2883–2886, 1996. Cited on page **308**.

88 The issue has been discussed within linearized gravity by RICHARD TOLMAN, in his textbook *Relativity, thermodynamics, and cosmology*, Clarendon Press, 1934, on pp. 272–290. The exact problem has been solved by A. PERES, *Null electromagnetic fields in general relativity theory*, *Physical Review* **118**, pp. 1105–1110, 1960, and by W.B. BONNOR, *The gravitational field of light*, *Commun. Math. Phys.* **13**, pp. 163–174, 1969. See also N.V. MITSKIEVIC & K.K. KUMARADTYA, *The gravitational field of a spinning pencil of light*, *Journal of Mathematical Physics* **30**, pp. 1095–1099, 1989. Cited on page **308**.

89 For a delightful popular account from a black hole expert, see IGOR NOVIKOV, *Black holes and the universe*, Cambridge University Press 1990. Cited on page **309, 316**.

- 90 ... CARILLI & al., *Limits on the change of fine structure constant ...*, Physical Review Letters 25 december 2000. Cited on page 309.
- 91 The geometrodynamical clock is discussed in D.E. BRAHM & R.P. GRUBER, *Limitations of the geometrodynamical clock*, General Relativity and Gravitation **24**, pp. 297–303, 1992. The clock itself was introduced by R.F. MARZKE, in his Ph.D. thesis *The theory of measurement in general relativity*, 1959, performed with John Wheeler as thesis advisor. Cited on page 311.
- 92 R. GEROCH, *Einstein Algebras*, Commun. Math. Phys. **26**, pp. 271–275, 1972. Cited on page 312.
- 93 A. MACDONALD, *Einstein's hole argument*, American Journal of Physics **69**, pp. 223–225, 2001. Cited on page 312.
- 94 See for example, the definition of the ADM mass in ... Cited on page 273.
- 95 For a historical introduction, see the paper ... R. Ruffini, *The physics of gravitationally collapsed objects*, ... Cited on page .
- 96 The observations of black holes at the centre of galaxies and elsewhere are summarized by R. BLANDFORD & N. GEHRELS, *Revisiting the black hole*, Physics Today **52**, June 1999. Cited on page 314, 324, 324.
- 97 J. MICHELL, Philosophical Transactions of the Royal Society London **74**, p. 35, 1784, reprinted in S. DETWEILER, *Black holes – selected reprints*, American Association of Physics Teachers, 1982. Cited on page 315.
- 98 The name black hole was introduced *in print* in the article by R. RUFFINI & J.A. WHEELER, *Introducing the black hole*, January, 1971. Cited on page .
- 99 The beautiful paper is R. OPPENHEIMER & H. SNYDER, ..., 1939. Cited on page 316.
- 100 R. KERR, Physical Review Letters **11**, p. 237, 1963. Cited on page 319.
- 101 E.T. NEWMAN, E. COUCH, R. CHINNAPARED, A. EXTON, A. PRAKASH & R. TORRENCE, Journal of Mathematical Physics **6**, p. 918, 1965. Cited on page 319.
- 102 M.A. ABRAMOWICZ & J.P. LASOTA, *On traveling round without feeling it and uncurving curves*, American Journal of Physics **54**, pp. 936–939, 1986. Cited on page .
- 103 For a summary, see P.O. MAZUR, *Black hole uniqueness theorems*, pp. 130–157, in M.A.H. MAC CALLUM, editor, *General relativity and gravitation*, 1987. Cited on page 319.
- 104 H.P. KÜNZLE, A.K.M. MASOOD-UL-ALAM, *Spherically symmetric static SU(2) Einstein-Yang-Mills fields*, Journal of Mathematical Physics **31**, pp. 928–935, 1990. Cited on page 319.
- 105 R. PENROSE & R.M. FLOYD, *Extraction of rotational energy from a black hole*, Nature **229**, pp. 177–179, 1971. Cited on page 320.
- 106 The mass energy relation for a rotating black hole is due to D. CHRISTODOULOU, *Reversible and irreversible transformations in black hole physics*, Physical Review Letters **25**, pp. 1596–1597, 1970. For a general, charged and rotating black hole it is due to D. CHRISTODOULOU & R. RUFFINI, *Reversible transformations of a charged black hole*, Physical Review D **4**, pp. 3552–3555, 1971. Cited on page 321.
- 107 J.D. BEKENSTEIN, *Black holes and entropy*, Physical Review **D7**, pp. 2333–2346, 1973. Cited on page 321.
- 108 The paradox is discussed in M.A. ABRAMOWICZ, *Black hole and the centrifugal force paradox*, Scientific American pp. 23–31, March 1993, and in the comment by DON N. PAGE, *Relative alternatives*, Scientific American p. 5, August 1993. See also M.A. ABRAMOWICZ & E. SZUSZKIEWICZ, *The wall of death*, American Journal of Physics **61**, pp. 982–991, 1993. Cited on page 323.

- 109** About black holes in the early universe, see ... Cited on page [323](#).
- 110** About black holes formation via star collapse, see ... Cited on page [323](#).
- 111** FREDERICK LAMB, APS meeting 1998, binary star 4U1820-30, 20 000 lightyears from earth, Physics News Update, April 27, 1998. Cited on page [324](#).
- 112** The first evidence for the observation of matter falling into a black hole was publicized in early 2001. ... Cited on page [324](#).
- 113** For a readable summary of the Penrose-Hawking singularity theorems, see ... Details can be found in reference [63](#). Cited on page [324](#).
- 114** For an overview of cosmic censorship, see T.P. SINGH, *Gravitational collapse, black holes, and naked singularities*, gr-qc/9805066 or R.M. WALD, *Gravitational collapse and cosmic censorship*, gr-qc/9710068. The original idea is due to R. PENROSE, *Rivista del Nuovo Cimento*, 1 p. 252, 1969. Cited on page [325](#).
- 115** THIBAULT DAMOUR, *Experimental tests of relativistic gravity*, <http://arxiv.org/gr-qc/9904057>. It is the latest in a series of his papers which started with THIBAULT DAMOUR, *Was Einstein 100% right?*, <http://arxiv.org/gr-qc/9412064>. Cited on page [326](#), [326](#), [327](#), [327](#), [327](#), [327](#), [327](#), [327](#), [327](#), [327](#), [327](#), [327](#).
- 116** H. DITTUS, F. EVERITT, C. LÄMMERZAHN & G. SCHÄFER, *Die Gravitation im Test*, *Physikalische Blätter* **55**, pp. 39–46, 1999. Cited on page [326](#), [326](#), [327](#).
- 117** The inverse square dependence has been checked down to 0.2 mm, as reported by ... *Physics Today* ...2000. Cited on page [327](#).
- 118** For theories competing with general relativity, see ... Among others, the absence of the Nordvedt effect, a hypothetical 28-day oscillation in the earth moon distance, looked for by laser ranging experiments without any result, killed several competing theories. This effect would appear if the gravitational energy in the earth-moon system would fall differently from the earth and the moon themselves. For a summary of the measurements, see J. MÜLLER, M. SCHNEIDER, M. SOFFEL & H. RUDER, *Astrophysical Journal Letters* **382**, p. L101, 1991. Cited on page [327](#).
- 119** See S. BÄSSLER & al., *Improved test of the equivalence principle for gravitational self-energy*, *Physical Review Letters* **83**, pp. 3585–3588, 1st November 1999. See also C. WILL, ..., *Physics Today* .., p. >>>, October 1999. Cited on page .
- 120** Almost everything of importance in general relativity is published in the Journal *Classical and quantum gravity*. For the US American side of research, see the webzine *Matters of Gravity*, published on <http://vishnu.nirvana.phys.psu.edu/mog.html>. Cited on page [328](#).
- 121** Collisions and many body problems ... Cited on page [328](#).
- 122** The study of chaos in Einstein's field equations is in its beginnings. See e.g. L. BOMBELLI, F. LOMBARDO & M. CASTAGNINO, *Chaos in Robertson-Walker Cosmology*, gr-qc/9707051. Cited on page [328](#).
- 123** Inflation and early universe ... Cited on page [328](#).
- 124** The best introduction into the topic of gamma ray bursts is S. KLOSE, J. GREINER & D. HARTMANN, *Kosmische Gammastrahlenausbrüche – Beobachtungen und Modelle*, Teil I und II, *Sterne und Weltraum* March and April 2001. Cited on page [328](#).
- 125** The field solution database is built around the work of A. Karlhede, which allows to distinguish solutions with a limited amount of mathematical computation. Cited on page [328](#).
- 126** Torsion ... Cited on page [328](#).
- 127** Wormholes and nontrivial topologies...A basic approach is the one by MARK HADLEY, *Classical and Quantum Gravity* October 2000. Cited on page [328](#).

- 128** Other formulations of relativity ... Cited on page [328](#).
- 129** Teaching will benefit in particular from new formulations, from concentration on principles and their consequences, as has happened in special relativity, from simpler descriptions at the weak field level, and from future research in the theory of general relativity. The newer textbooks cited above all are steps in these directions. Cited on page [328](#).
- 130** A beautiful introduction into modern astronomy is PAOLO MAFFEI, *I mostri del cielo*, Mondadori Editore, 1976. Cited on page .
- 131** MICHAEL H. SOFFEL, *Relativity in astronomy, celestial mechanics and geodesy*, Springer Verlag, 1989. Cited on page .
- 132** M. NAGANO & A.A. WATSON, *Observations and implications of the ultrahigh energy cosmic rays*, *Reviews of Modern Physics* **72**, pp. 689–732, 2000. Cited on page .
- 133** The speed of light as function of height has been checked e.g. by ... The change is smaller than ... Cited on page .
- 134** STEVEN WEINBERG, *The cosmological constant problem*, *Reviews of Modern Physics* **61**, pp. 1–23, 1989. This influential review article on the views on cosmological constant problem at that time is frequently cited. Cited on page .
- 135** A. ASHTEKAR, 1986, *New variables for classical and quantum gravity*, *Physical Review Letters* **57**, pp. 2244–2247, Cited on page .
- 136** The new book by R. WALD, ... Cited on page .
- 137** A well written text on the connections between the big bang and particle physics is by I.L. ROZENTAL, *Big bang – big bounce, how particles and fields drive cosmic evolution*, Springer, 1988. Cited on page .



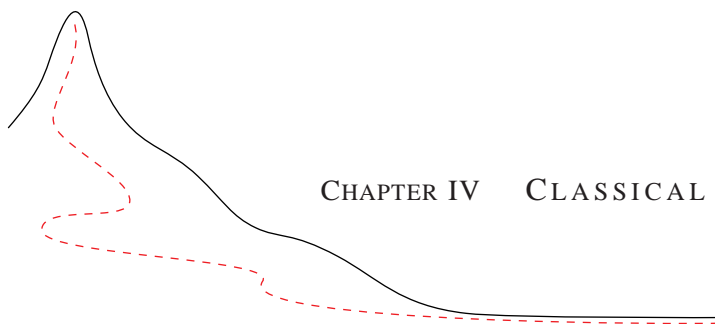

CHAPTER IV CLASSICAL ELECTRODYNAMICS

What is light? The study of relativity left us completely in the dark, even though we had embarked in it for precisely that aim. True, we have learned how the motion of light compares to that of objects. We also learned that light is that moving entity which cannot be stopped; but we haven't learned anything about its own nature. The answer to this old question emerges only from the study of those types of motion which are *not* related to gravitation, such as the way magicians levitate objects.

13. Liquid electricity, and invisible fields

Revisiting the list of of motors one finds in this world, one remarks that gravitation does not describe almost any of them. Neither the motion of sea waves, of fire, of earthquakes, nor that of a gentle breeze are due to gravity. The same applies to the motion of muscles. Have you ever listened to your own heart beat, e.g. with a stethoscope? Without having done so, nobody can pretend to have experienced the mystery of motion. You have about 3000 million beats in your lifetime. Then they stop.

See page 105

Challenge 164

It was one of the most astonishing discoveries of science that all these and most other cases of everyday motion, as well as the nature of light itself, are connected to observations performed already thousands of years ago with two strange stones. These stones show that all examples of motion which are called *mechanical* in everyday life, are, without exception, of *electrical* origin.

In particular, the solidity of matter, its softness and its impenetrability are due to internal electricity; also the emission of light is. As these aspects are part of everyday life, we leave aside all complications due to gravity and curved space-time. Again, the most productive way to proceed is to study first, like in the case of gravity, those types of motion which are generated without any contact between the involved bodies.

Amber, lodestone, and mobile phones

Any fool can ask more questions
than seven sages can answer.

The story of electricity starts with trees. Trees have a special relation to electricity. When one cuts a tree, a viscous resin appears. With time it solidifies, and after millions of years it forms *amber*. When one rubs amber with a cat fur, it acquires the ability to attract small objects, such as saw dust or pieces of paper. This was already known to Thales of Miletus, one of the original seven sages, in the sixth century BCE. The same observation can be made with many other polymer combinations, for example with combs and hair, with shoe soles and carpets, or with TV screens and dust. Even children are always surprised by the effect a rubbed comb has on a running water tap.

Challenge 181

The other part of the story is about an iron mineral found in certain caves around the world, e.g. in Greece, in the province of Thessalia, in a region (still) called Magnesia, or in China. When one puts two stones of this mineral near each other, they attract or repel each other, depending on their relative orientation. In addition, these stones attract objects made of cobalt, nickel, or iron.

Today one also finds various little objects in nature with more sophisticated properties. Some are able to switch on televisions, others unlock car doors, still others allow to talk with far away friends.

All these observations show that in nature there are situations where bodies exert influence on others *at a distance*. The space surrounding a body with such an influence is said to contain a *field*. A (*physical*) *field* is thus an entity which manifests itself by accelerating other bodies in that region of space. A field is some ‘stuff’ taking up space, but obviously having no mass. The field surrounding the mineral found in Magnesia is called a *magnetic field* and the stones themselves *magnets*.* The field around amber – called $\epsilon\lambda\epsilon\chi\tau\rho\omicron\nu$ in Greek, from a root meaning ‘brilliant, shining’ – is called an *electric field*. The name is due to a proposal by the famous English part-time physicist William Gilbert (1544–1603) who was the physician of Queen Elizabeth. Objects surrounded by a permanent electric field are called *electrets*. They are much less common than magnets; among others, they are used in certain loudspeaker systems.**

The field around a mobile phone is called a *radio field*, or as we will see later, an *electromagnetic field*. We will find out later that many other objects are surrounded by such fields, though often very weak. Objects such as mobile phones are called radio transmitters or radio emitters.

Fields influence other bodies over a distance, without any material support. For a long time, this was quite rare in everyday life, as laws in most countries have strict upper lim-

* A pretty book about the history of magnetism and the excitement it generates is JAMES D. LIVINGSTON, *Driving force – the natural magic of magnets*, Harvard University Press, 1996.

** The Kirlian effect, which allows to make so intriguingly beautiful photographs, is due to a time-varying electric field.

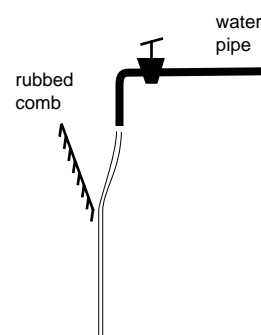

Figure 140 How to amaze kids

Search	Magnetic charge
Smallest magnetic charge suggested by quantum theory	$g = \frac{h}{e} = \frac{eZ_0}{2\alpha} = 4.1 \text{ pWb}$
Search in minerals	none Ref. 2
Search in meteorites	none Ref. 2
Search in cosmic rays	none Ref. 2
Search with high energy accelerators	none Ref. 2

Table 30 Some searches for magnetic monopoles, i.e., for magnetic charges

Observation	Magnetic field
Lowest measured magnetic field	ca. 1 fT
Magnetic field produced by brain currents	ca. 0.1 pT to 3 pT
Intergalactic magnetic fields	1 pT to 10 pT
Magnetic field in the human chest, due to heart currents	ca. 100 pT
Magnetic field of our galaxy	0.5 nT
Magnetic field of earth	20 μ T to 70 μ T
Magnetic field below high voltage power line	ca. 10^{-7} T
Magnetic field inside modern home	10^{-7} T to 10^{-4} T
Magnetic field near mobile phone	ca. 10^{-7} T
Magnetic field in light beam	... T
Magnetic field near iron magnet	100 mT
Solar spots	ca. 1 T
Magnetic fields near high tech permanent magnet	max 1.3 T
Magnetic fields in particle accelerator	ca. 10 T
Maximum magnetic field produced with superconducting coils	22 T
Highest long time static magnetic fields produced in laboratory using hybrid magnets	50 T
Highest <i>pulsed</i> magnetic fields produced without coil destruction	74 T
Pulsed magnetic fields produced, during about 1 μ s, using imploding coils	ca. 1000 T
Field on neutron star	from 10^6 T to 10^{11} T
Quantum critical magnetic field	ca. $6 \cdot 10^9$ T
Highest field ever measured, on magnetar SGR-1806-20	$0.8 \cdot 10^{11}$ T
Maximum (Planck) magnetic field	$2.2 \cdot 10^{53}$ T

Table 31 Some observed magnetic fields

its for machines using and producing such fields. For any device which moves, produces sounds, or creates moving pictures, the fields are usually required to remain inside them. For this reason magicians moving an object on a table via a hidden magnet still continue to surprise and entertain their public. To feel the fascination of fields more strongly, a deeper look into a few experimental results is worthwhile.

How can one make lightnings?

Everybody has seen a lightning or has observed the effect it can have when hitting a tree. Obviously lightning is a moving phenomenon. Photographs show that their tips advance with a speed of over 10^5 m/s. But *what* is moving? To find out, one has to find a way to make lightnings oneself.

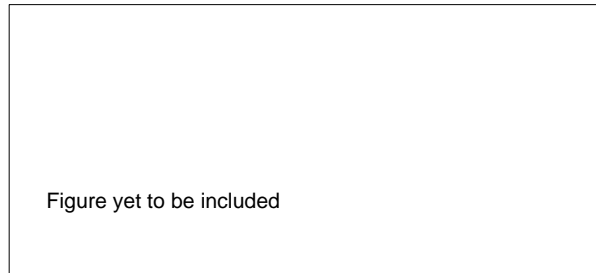

Figure 141 Lightning: a picture taken with a moving camera, showing the multiple strokes it consists of

In 1995, the car company General Motors accidentally rediscovered an old and simple method for achieving this. They had inadvertently build a spark generating mechanism into their cars; when filling the tank with fuel, sparks were generated which sometimes lead to the explosion of the fuel. They had to recall 2 million vehicles of its Opel brand. What had they done?

Ref. 3

The engineers had unknowingly copied the conditions for a electrical device which everybody can build at home and which was originally invented by William Thomson.* Repeating his experiment today, one would take a few water taps, four empty bean or coffee cans, of which two have been opened at both sides, some nylon rope and some metal wire.

Ref. 4

Putting all together as shown in Figure 142 and letting the water flow, one finds a strange effect: strong sparks periodically jump between the two copper wires at the point where they are nearest to each other, making loud bangs. Can you guess what condition for the flow has to be realized for this to work? And what Opel did to repair the cars?

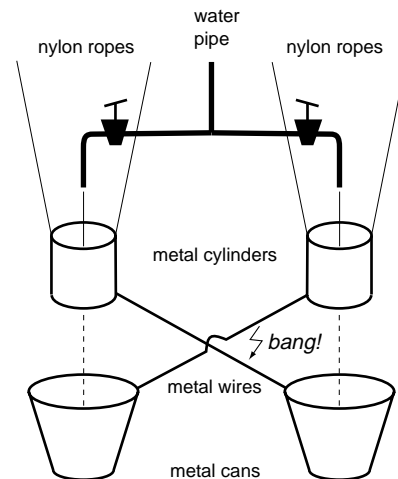

Figure 142 A simple Kelvin generator

Challenge 198

If one stops the water flow just before the next spark is due, one finds that both buckets attract sawdust and pieces of paper. The generator thus does the same that rubbing amber does, just with more bang for the buck(et). Both buckets are surrounded by electric fields. The field increases with time, until the spark jumps. Just after the spark, the buckets are (almost) without electric field. Obviously, the flow of water somehow builds up an entity on each bucket, today called *electric charge*, which can flow in metals and, when

* William Thomson (1824–1907), important unionist Irish physicist, professor in Glasgow. He worked on the determination of the age of the earth, showing that it was much older than 6000 years, as several sects believed; he strongly influenced the development of the theory of magnetism and electricity, the description of the aether, and thermodynamics. He propagated the use of the term 'energy' as it is common today, instead of the unclear older terms. He was one of the last scientists propagating mechanic analogies for the explanation of phenomena, and thus strongly opposed Maxwell's description of electromagnetism. Probably for this reason he did not receive a Nobel prize. He also was one of the minds behind the laying of the first transatlantic telegraphic cable. Victorian to his bones, when he was was made a Lord, he chose the name of a small brook near his home as his new name; thus he became Lord Kelvin of Largs. Therefore the temperature unit got its name from a small English river.

the fields are high enough, through air. One also finds that the two buckets are surrounded by two different types of electric fields: bodies which are attracted by one bucket are repelled by the other. All other experiments confirm that there are *two* types of charges. The US politician and part-time physicist Benjamin Franklin (1706–1790) called the electricity created on a glass rod rubbed with a dry cloth *positive*, the one on a piece of amber *negative*. (Before him, the two types of charges used to be called called ‘vitreous’ and ‘resinous’.) Bodies with charges of the same sign repel each other, bodies with opposite charges attract each other; charges of opposite sign flowing together cancel each other out.*

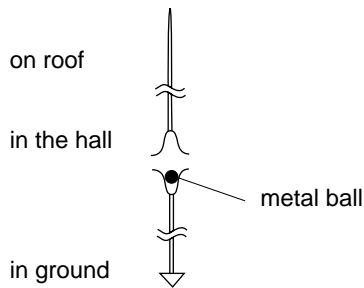

Figure 143 Franklin’s personal lightning rod

In summary, electric fields start at bodies, provided they are charged. Charging is possible by rubbing and similar processes. Charge can flow, and then is called electric current. The worst conductors of current are polymers; they are often called insulators. Metals are the best conductors, especially silver and copper. This is the reason that at present, after hundred years of use of electricity, the highest concentration of copper in the world is below the surface of Manhattan.

Of course, one has to check whether real thunderstorm lightnings actually are electrical in origin. In 1752, experiments performed in France, following a suggestion of Benjamin Franklin published in London in 1751, showed that one can indeed draw electricity from thunderstorms via a long rod.** These French experiments rendered Franklin world famous; they also started the use of lightning rods throughout the world. Later on, Franklin had a lightning rod built through his own house, but of a somewhat unusual type, as shown in Figure 143. Can you guess what it did in his hall during bad weather, all parts being made of metal?

Challenge 215

What is electric charge?

If all experiments with charge can be explained by calling the two charges positive and negative, the implication is that some bodies have more, and some less charge than the uncharged, *neutral* ones. Electricity thus only flows when two differently charged bodies are brought into contact. Now, if charge can flow and accumulate, one must be able to somehow measure its amount. Obviously, the *amount* of charge on a body, usually abbreviated q , is defined via the influence the body, say a piece of saw dust, feels when subjected to a field. Charge is thus defined by comparing it to a standard reference charge. For a charged body of mass m accelerated in a field, its unknown charge q is determined by the relation

$$\frac{q}{q_{\text{ref}}} = \frac{ma}{m_{\text{ref}}a_{\text{ref}}}, \quad (325)$$

* In fact, there are many other ways to produce sparks or even *arcs*, i.e. sustained sparks; there is even a complete subculture of people who do this as a hobby at home. Those who have a larger budget do it professionally, in particle accelerators. See the <http://www.mathematik.uni-marburg.de/kronjaeg/hv/index.html> web site.

** There is still research going on into the details of how lightnings are generated and how they propagate. A little about this topic is said on page 382.

This is a section of the freely downloadable e-textbook

Motion Mountain

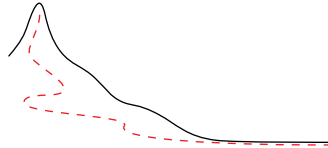

Hiking beyond space and time along the concepts of modern physics

available at
www.motionmountain.org

Copyright © 1997, 1998, 1999, 2000, 2001, 2002 by Christoph Schiller

To the kind reader

In exchange for getting this section for free, I ask you for a short email on some of the following:

- Which page was boring?
- Did you find any mistakes?
- What else were you expecting?
- What was hard to understand?

Of course, any other suggestion is welcome. This section is part of a physics text written over many years. The text lives and grows through the feedback from its readers, who help to improve and to complete it. For a particularly useful contribution (send it in english, italian, dutch, german, spanish, portuguese, or french) you will be mentioned in the foreword of the text, or receive a small reward, or both.

Enjoy!

Christoph Schiller
cs@motionmountain.org

Challenge 232

Charges	Physical property	Mathematical name (see later for definitions)
can be compared	distinguishability	set
can be ordered	sequence	order
can change gradually	continuity	completeness
can be stored	accumulability	additivity
don't change	conservation	invariance
can be divided	separability	positive or negative

Table 32 Properties of classical electric charge

Observation	Charge
Smallest known non-vanishing charge	$0.5 \cdot 10^{-19} \text{ C}$
Charge per bit in computer memory	10^{-13} C
Charge in small capacitor	10^{-7} C
Charge flow in average lightning stroke	1 C to 100 C
Charge stored in a full car battery	0.2 MC
Charge of planet earth	ca. 1 MC
Charge separated by modern power station in one year	ca. $3 \cdot 10^{11} \text{ C}$
Total charge of one sign observed in universe	ca. $10^{62 \pm 2} \text{ C}$

Table 33 Values of electrical charge observed in nature

i.e., by comparing it to the acceleration and mass of the reference charge. This definition reflects the observation that mass alone is not sufficient for a complete characterization of a body. For a full description of motion one needs to know its electric charge; charge is therefore the second intrinsic property of bodies we discover in our walk.

By the way, the unit of charge, the *coulomb*, is nowadays defined through a standard flow through metal wires, as explained in Appendix B. This is possible because all experiments show that charge is conserved, that it flows, that it flows continuously, and that it can accumulate. Charge thus behaves like a fluid substance. Therefore one is forced to use for its description a scalar quantity q , which can take positive, vanishing, or negative values.

In everyday life these properties of electric charge, listed also in Table 32, describe observations with sufficient accuracy. But as in the case of all previously encountered classical concepts, these experimental results about electrical charge will turn out to be only approximate. More precise experiments will require a revision of several properties.

Experiments show that the entity which accelerates charged bodies, the *electric field*, behaves like a little arrow fixed at each place \mathbf{x} in space; its length and its direction does not depend on the observer. In short, the electric field $\mathbf{E}(\mathbf{x})$ is a *vector* field. Experiments show that it is best defined by the relation

$$q\mathbf{E}(\mathbf{x}) = m\mathbf{a}(\mathbf{x}) \quad (326)$$

taken at every point in space \mathbf{x} . The definition of the electric field is thus indeed based on

Observation	Electric field
Cosmic noise	ca. $10 \mu\text{V}/\text{m}$
Field 1 m away from an electron	...
Field of a 100 W FM radio transmitter at 100 km distance	$0.5 \text{ mV}/\text{m}$
Field in solar wind	...
Field in clouds	...
Field inside conductors, such as copper wire	$0.1 \text{ V}/\text{m}$
Field of a 100 W bulb at 1 m distance	$50 \text{ V}/\text{m}$
Ground field in earth's atmosphere	100 to $300 \text{ V}/\text{m}$
Maximum electric field in air before sparks appear	ca. $1 \text{ MV}/\text{m} = 1 \text{ kV}/\text{mm}$
Electric fields in biological membranes	$10 \text{ MV}/\text{m}$
Electric fields inside capacitors	up to $1 \text{ GV}/\text{m}$
Electric fields in most intense laser beams	$100 \text{ TV}/\text{m}$
Electric fields in U^{91+} ions, at nucleus	$1 \text{ EV}/\text{m}$
Maximum electric field in vacuum, limited by pair production	$1.3 \text{ EV}/\text{m}$
Planck electric field	$6.5 \cdot 10^{61} \text{ V}/\text{m}$

Table 34 Some observed electric fields

Challenge 266 how it *moves* charges. * The field is measured in multiples of the unit N/C or the identical unit V/m.

To describe motion due to electricity completely, one also needs a relation explaining how charges *produce* electric fields. This relation was first established with precision by Charles-Augustin de Coulomb in his private estate, during the French revolution. ** He found that around a small or spherical charge Q *at rest* there is an electric field given by

$$\mathbf{E}(\mathbf{r}) = \frac{1}{4\pi\epsilon_0} \frac{Q}{r^2} \frac{\mathbf{r}}{r} \quad \text{where} \quad \frac{1}{4\pi\epsilon_0} = 8.9 \text{ GVm}/\text{C} \quad . \quad (327)$$

Challenge 283 Later on we will extend the relation for a charge in motion. The strange proportionality constant is due to the historical way the unit of charge was defined first. *** The essential point of the formula is the decrease of the field with the square of the distance; can you imagine the origin of this dependence?

The two previous equations allow to write the interaction between two charged bodies as

$$\frac{d\mathbf{p}_1}{dt} = \frac{1}{4\pi\epsilon_0} \frac{q_1 q_2}{r^2} \frac{\mathbf{r}}{r} = -\frac{d\mathbf{p}_2}{dt} \quad (328)$$

where \mathbf{p} is the momentum change, and \mathbf{r} is the vector connecting the two centres of mass. This famous expression for electrostatic attraction and repulsion, also due to Coulomb, is valid only for small or for spherical charged bodies *at rest*.

Challenge 249 * Does the definition of electric field given here assume a speed of the charge much smaller than that of light?
 ** Charles-Augustin de Coulomb (1736, Angoulême–1806, Paris), French engineer and physicist. His careful experiments on electric charges provided the basis for the study of electricity.
 *** Other definitions of this and other proportionality constants to be encountered later are possible, leading to *unit systems* different from the SI system used here. The SI system is presented in detail in Appendix B. Among the older competitors, the gaussian unit system often used in theoretical calculations, the Heaviside-Lorentz unit system, the electrostatic unit system, and the electromagnetic unit system are the most important ones. For more details, see the standard text by J.D. JACKSON, *Classical electrodynamics*, 3rd edition, Wiley, 1998,

The strength of this interaction is considerable. For example, it is the basis for the force of our muscles. Their force is a macroscopic effect of this equation. Another example is provided by the strength of steel or diamond. As we will discover, its atoms, and those of any other material, are kept together by electrostatic attraction. As a final example to convince yourself of the strength of electrostatic attraction, answer the following: What is the force between two boxes with a gram of protons each, located on the two poles of the earth? Try to guess the result, before you calculate the astonishing value.

Challenge 300

Due to the strength of electromagnetic interactions, separating charges is not an easy task. This is the reason that electrical effects are in common use only for about a hundred years. One had to wait for the invention of practical and efficient devices for separating charges and putting them into motion. Of course this implies the use of energy. Batteries, as used e.g. in portable phones, use chemical energy to do the trick,* thermoelectric elements, as used in some watches, use the temperature difference between the wrist and the air to separate charges, solar cells use light, and dynamos or the Kelvin generator use kinetic energy.

Do uncharged bodies attract each other? In first approximation they do not. But when studying the question more precisely, they can attract each other. Can you find the conditions for this to happen? In fact, the conditions are quite important, as our own bodies hold together in this way.

Challenge 334

What then is electricity? The answer is simple: *electricity is nothing in particular*. It is the name for a field of inquiry, but not the name for any specific observation or effect. Electricity is neither electric current, nor electric charge, nor electric field. It is not a specific term; it applies to *all* of these phenomena. One has to be a little careful when using it. In fact the vocabulary issue hides a deeper question, which was unanswered in the twentieth century: what is the nature of electric charge? Since charge flows, one can start by asking:

Can one feel the inertia of electricity?

If electric charge really is something *flowing* through metals, one should be able to observe the effects shown in Figure 144, as already Maxwell predicted. Electric charge should fall, have inertia, and be separable from matter. And indeed, each of these effects has been observed.** For example, when a long metal rod is kept vertically, one can measure an electrical potential difference, a voltage, between the top and the bottom. In other words, one can measure the *weight* of electricity this way. Similarly, one can measure potential differences between the ends of an accelerated rod. In particular, one can measure a potential difference between the centre and the rim of a rotating metal disk. This latter experiment was in fact the way in which the ratio q/m for currents in metals was first measured with precision. The result is

Ref. 5

$$q/m = 1.8 \cdot 10^{11} \text{ C/kg} \quad (329)$$

for all metals, with small variations. In short, electrical current has mass. Therefore, whenever one switches on an electrical current, one gets a *recoil*. This simple effect can easily be measured and confirms the mass to charge ratio just given. Also the emission of current into

Ref. 6

Challenge 317 * By the way, are batteries sources of charges?

** Maxwell tried to detect these effects (apart from the last one, which he did not predict), but his apparatuses were not sensitive enough.

Ref. 7 air or into vacuum is observed; in fact, every television tube uses this principle to generate the beam producing the picture. It works best when metal objects have a sharp, pointed tip. The rays created this way – one could say that they are ‘free’ electricity – are called *cathode rays*. Within a few percent, they show the same mass to charge ratio as expression (329). This correspondence thus shows that charges in metals move almost as freely as in air; that is the reason metals are such good conductors.

If electric charge falls inside vertical metal tube, one can take the astonishing deduction that cathode rays – as we will see later, they consist of free electrons* – should not be able to fall through a vertical metal tube. This is due to the fact that the electrical field generated by the displaced electricity in the tube precisely compensates the acceleration of gravity, so that electrons should not be able to fall through long thin cylinders. The experiment has indeed been performed, and a reduction of the acceleration of free fall for electrons of 90% has been observed. Can you imagine why the ideal value of 100% is not achieved?

Challenge 351

Ref. 8

How fast do charges move?

In vacuum, such as inside a colour television, charges accelerated by a tension of 30 kV move with a third of the speed of light. In modern particle accelerators charges move so rapidly that their speed is indistinguishable from that of light for all practical purposes.

Challenge 368

In metals, electric signals move roughly with speeds around the speed of light. (Actually, the precise value depends on the capacity of the cable, and is usually in the range $0.3c$ to $0.5c$.) But when one measures the speed of charges inside metals one gets the same value as for ketchup inside its bottle, namely around 1 mm/s. Are you able to explain this apparent contradiction?

Challenge 385

* The name ‘electron’ is due to Johnstone Stoney. Electrons are the smallest and lightest charges moving in metals; they are, usually, the ‘atoms’ of electricity. Their charge is small, 0.16 aC , so that flows of charge typical of everyday life consist of large numbers of electrons; as a result, they behave like a continuous fluid.

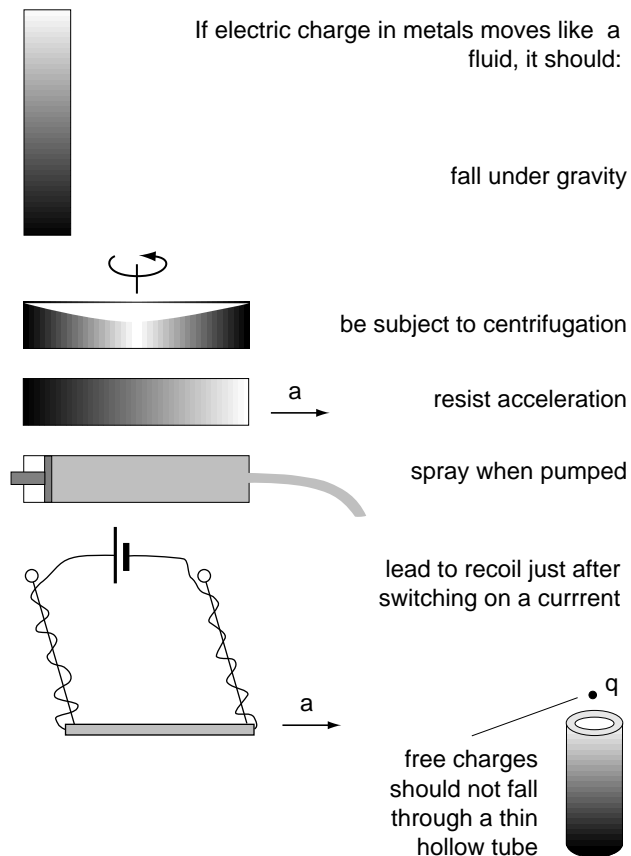

Figure 144 Consequences of the flow of electricity

In atoms, electrons behave even more strangely. One tends to think that they turn around the nucleus (as we will see later) at rather high speed, as the orbit is so small. However, it turns out that in most atoms many electrons do not turn around the nucleus at all. The strange story behind this fact will be told in the second part of this mountain ascent.

Inside fluids, charges move with different speed than inside metals, and their charge to mass ratio is also different. We all know that from direct experience. Our *nerves* work by using electric signals and take (only) a few milliseconds to respond to stimuli, even though they are metres long. A similar speed is observed inside semiconductors and inside batteries. The details will become clear in the next part of the mountain ascent.

How can one make a motor?

Communism is soviet plus electricity.
 Lenin (1870, Simbirsk-1924, Gorki)

The reason for this famous statement were two discoveries. One was made in 1820 by the Danish physicist Hans Christian Oersted (1777–1851) and the other in 1831 by the English physicist Michael Faraday.* The consequences of these experiments changed the world completely in less than one century.

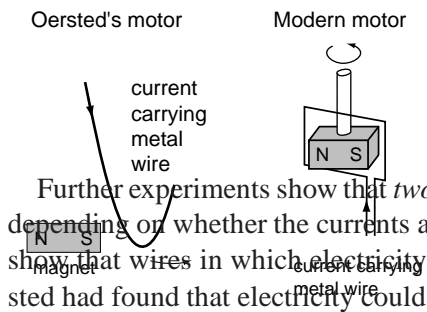

On the 21st of July of 1821, Oersted published a leaflet, in Latin, which took Europe by storm. Oersted had found that when a current is sent through a wire, a nearby magnet is put into motion. In other words, he found that the flow of electricity can move bodies.

Further experiments show that *two* wires in which charges flow attract or repel each other, depending on whether the currents are parallel or antiparallel. These and other experiments show that wires in which electricity flows behave the like magnets.** In other words, Oersted had found that electricity could be turned into magnetism.

Shortly afterwards, Ampère*** found that *coils* increase these effects dramatically. Coils behave like little magnets. In particular, coils, like magnetic fields, have always two poles, usually called the north and the south pole. Opposite poles attract, similar poles repel each other.

* Michael Faraday (1791, Newington, Surrey–1867) born in a simple family, without schooling, of deep and simple religious ideas, as a boy he became assistant of the most famous chemist of his time, Humphry Davy. Without mathematical training, at the end of his life he became member of the Royal society. A modest man, he refused all other honours in his life. He worked on chemical topics, the atomic structure of matter, and most of all, developed through all his experimental discoveries, such as induction, paramagnetism, diamagnetism, electrochemistry, the Faraday effect, and the idea of (magnetic) field and field lines. Fields were later described mathematically by Maxwell, who at his time was the only one in Europe who took over the concept.

** In fact, if one imagines tiny currents moving in circles inside magnets, one has the same description for all magnetic fields observed in nature.

*** André-Marie Ampère (1775, Lyon–1836, Marseille), French physicist and mathematician. Autodidact, he read the famous *encyclopédie* as a child; in a life full of personal tragedies, he wandered from maths to chemistry and physics, worked as a high school teacher, and published nothing of importance until 1820. Then the discovery of Oersted reached all of Europe: electrical current can deviate magnetic needles. Ampère worked for years on the problem, and published in 1826 the summary of his findings, which lead Maxwell to call him the Newton of electricity. He named and developed many parts of electrodynamics. The unit of electrical current is named after him.

other. As is well known, the earth is itself a large magnet, with its magnetic north pole near the geographic south pole, and vice versa.

Experiments show that the magnetic field turns out to always have a given direction in space, and to have a magnitude common to all (resting) observers. One is tempted to describe it by a vector. However, this is wrong, since a magnetic field does not behave like an arrow when placed before a mirror. It turns out that a magnetic field pointing towards a mirror does not change direction for the mirror set up. Are you able to confirm this using what was told about magnetic fields up to now?

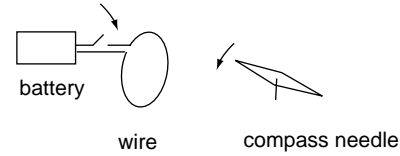

Figure 146 An electrical current always produces a magnetic field

Challenge 402

In other words, it is not completely correct to describe a magnetic field by a vector $\mathbf{B} = (B_x, B_y, B_z)$; the precise way is to describe it by the quantity *

$$\mathbf{B} = \begin{pmatrix} 0 & -B_z & B_y \\ B_z & 0 & -B_x \\ -B_y & B_x & 0 \end{pmatrix}, \tag{330}$$

called an *antisymmetric tensor*. (It is also called a *pseudovector*; note that also angular momentum and torque are examples of such quantities.) In summary, *magnetic fields* are defined by the acceleration they impart on moving charges. This acceleration turns out to follow

$$\mathbf{a} = \frac{e}{m} \mathbf{v} \mathbf{B} = \frac{e}{m} \mathbf{v} \times \mathbf{B} \tag{331}$$

a relation which is often called *Lorentz acceleration* after the important Dutch physicist Hendrik A. Lorentz (Arnhem, 1853–Haarlem, 1928) who first stated it clearly. ** The Lorentz acceleration is the effect at the basis of any electric motor. An electric motor is a device using magnetic fields as efficiently as possible to accelerate charges flowing in a wire. Through their motion the wire is then moved as well, and thus electricity is transformed into motion.

Like in the electric case, we now need to know how the *strength* of magnetic fields is determined. Experiments like Oersted’s show that the magnetic field is due to moving charges, and that a charge moving with velocity \mathbf{v} produces a field given by

$$\mathbf{B}(\mathbf{r}) = \frac{\mu_0}{4\pi} q \frac{\mathbf{v} \times \mathbf{r}}{r^3} \quad \text{where} \quad \frac{\mu_0}{4\pi} = 10^{-7} \text{ N/A}^2 \tag{332}$$

Again, the strange factor $\mu_0/4\pi$ is due to the historical way the electrical units were defined. It is easy to see that the field has an intensity given by $\mathbf{v}\mathbf{E}/c^2$, where \mathbf{E} is the electric field measured by an observer moving *with* the charge. It looks as if magnetism is a relativistic

Challenge 436

* The quantity \mathbf{B} was not called ‘magnetic field’ until recently. We follow here the modern, logical definition, which is superseding the traditional one, in which \mathbf{B} was called the ‘magnetic flux density’ or ‘magnetic induction’ and a different quantity, \mathbf{H} , was called – incorrectly – the magnetic field. That quantity will not appear in this walk, but is important for the description of magnetism in materials.

** Does the definition of magnetic field given here assume a speed of the charge much smaller than that of light?

Challenge 419

effect.***

In 1831, Michael Faraday discovered an additional piece of the puzzle. He found that a moving magnet could cause a current flow in an electrical circuit. Magnetism can thus also be turned into electricity. This important discovery allowed the production of electrical current flow with generators, so-called *dynamos*, using water power, wind power or steam power. They starting the modern use of electricity in our world. Behind every electrical plug there is a dynamo somewhere.

Additional experiments show that magnetic fields also lead to electric fields when one changes to a moving viewpoint, as you might check on any of the examples of the Figures 145 to 149. *Magnetism indeed is relativistic electricity*. Electric and magnetic fields are partly transformed into each other when switching from one inertial reference frame to the other. Magnetic and electrical fields thus behave like space and time, which are also mixed up when changing from one inertial frame to the other. The theory of special relativity then tells us that there must be a single concept, an *electromagnetic field*, describing them both. Investigating the details, one finds that the electromagnetic field F surrounding charged bodies has to be described by an antisymmetric 4-tensor

$$F^{\mu\nu} = \begin{pmatrix} 0 & -E_x/c & -E_y/c & -E_z/c \\ E_x/c & 0 & -B_z & B_y \\ E_y/c & B_z & 0 & -B_x \\ E_z/c & -B_y & B_x & 0 \end{pmatrix} \quad \text{or} \quad F_{\mu\nu} = \begin{pmatrix} 0 & E_x/c & E_y/c & E_z/c \\ -E_x/c & 0 & -B_z & B_y \\ -E_y/c & B_z & 0 & -B_x \\ -E_z/c & -B_y & B_x & 0 \end{pmatrix} \quad (333)$$

Obviously, the electromagnetic field, and thus every component of these matrices, depends on space and time. The matrices show that electricity and magnetism are two faces of the same effect; in addition, since electric fields appear only in the topmost row and leftmost column, the expressions show that in everyday life, for small speeds, electricity and magnetism *can* be separated.

Actually, the expression for the field contains everywhere the expression $1/\sqrt{\mu_0\epsilon_0}$ instead of the speed of light c . We will explain the reason for this substitution shortly.

The total influence of electric and magnetic fields on fixed or moving charges is then given by the following expression:

$$\begin{aligned} m\mathbf{b} &= F\mathbf{u} \quad \text{or} \\ m \frac{d\mathbf{u}^\mu}{d\tau} &= qF^\mu{}_\nu u^\nu \quad \text{or} \\ m \frac{d}{d\tau} \begin{pmatrix} \gamma c \\ \gamma v_x \\ \gamma v_y \\ \gamma v_z \end{pmatrix} &= q \begin{pmatrix} 0 & E_x/c & E_y/c & E_z/c \\ E_x/c & 0 & B_z & -B_y \\ E_y/c & -B_z & 0 & B_x \\ E_z/c & B_y & -B_x & 0 \end{pmatrix} \begin{pmatrix} \gamma c \\ \gamma v_x \\ \gamma v_y \\ \gamma v_z \end{pmatrix} \quad \text{or} \\ W &= q\mathbf{E}\mathbf{v} \quad \text{and} \quad d\mathbf{p}/dt = q(\mathbf{E} + \mathbf{v} \times \mathbf{B}) \end{aligned} \quad (334)$$

All four expressions describe the same content; the simplicity of the first one is the reason for the involved matrices (333) of the electromagnetic field. In fact, the extended *Lorentz relation* (334) is the *definition* of the electromagnetic field, since the field is defined as that

Challenge 453 *** Equation (332) is valid only for small velocities and accelerations. Can you find the general one?

‘stuff’ which accelerates charges. In particular, all devices which put charges into motion, such as batteries and dynamos, as well as all devices which are put into motion by flowing charges, such as electric motors and muscles, are described by this relation. That is why it is usually studied already in high school. The Lorentz relation describes all cases in which the motion of objects can be seen by the naked eye or felt by our senses, such as the movement of electrical motors in high speed trains, in elevators and in dental drills, the motion of the picture generating electron beam in television tubes, or the travelling of electrical signals in cables and in the nerves of the body.

Ref. 9, 10

The electromagnetic field tensor F is an *antisymmetric* 4-tensor. (Can you write down the relation between $F^{\mu\nu}$, $F_{\mu\nu}$, and $F^{\mu}{}_{\nu}$?) Like any such tensor, it has two invariants, i.e., two properties which are the same for every observer: the expression $B^2 - E^2/c^2 = \frac{1}{2}\text{tr}F^2$ and the product $4\mathbf{EB} = -c \text{tr}F^*F$. (Can you confirm this?)

Challenge 470

Challenge 487

The first expression turns out to be the Lagrangian of the electromagnetic field. It is a scalar and implies that if E is larger, smaller, or equal cB for one observer, it also is for all other observers. The second invariant, a pseudoscalar, describes whether the angle between the electric and the magnetic field is acute or obtuse for all observers.*

The application of electromagnetic effects to daily life has opened up a whole new world which did not exist before. Electrical light, electric motors, radio, telephone, X-rays, television, and computers changed human life completely in less than one century. For example, the installation of electric lighting in city streets has almost eliminated the previously so common night assaults. These and all other electrical devices use the fact that charges can flow in metals, that one can translate electromagnetic energy into mechanical energy (sound, motors), into light (lamps), into heat and coldness (ovens, refrigerators), that one can send electromagnetic fields across the air (radio and television, remote controls), and that one can use electric or magnetic fields to store information (computers).

How motors prove relativity right

The only mathematical operation I performed in my life was to turn the handle of a calculator.
Michael Faraday

All electric motors are based on the result that electric currents interact with magnetic fields. The simplest example is the attraction of two wires carrying parallel currents. This observation alone, made in 1820 by Ampère, is sufficient to make motion larger than a certain maximal speed impossible.

Ref. 12

* There is in fact a third Lorentz invariant, much less known. It is specific to the electromagnetic field and is a combination of the field and its vector potential:

$$\begin{aligned} \kappa_3 &= \frac{1}{2}A_{\mu}A^{\mu}F_{\rho\nu}F^{\nu\rho} - 2A_{\rho}F^{\rho\nu}F_{\nu\mu}A^{\mu} \\ &= (\mathbf{AE})^2 + (\mathbf{AB})^2 - |\mathbf{A} \times \mathbf{E}|^2 - |\mathbf{A} \times \mathbf{B}|^2 + 4A^4(\mathbf{AE} \times \mathbf{B}) - A^8(E^2 + B^2) \end{aligned} \tag{335}$$

Ref. 11

This expression is Lorentz (but not gauge) invariant; knowing it can help clarify unclear issues, such as the lack of existence of waves in which the electric and the magnetic field are parallel. Indeed, for plane monochromatic waves all three invariants *vanish* in the Lorentz gauge. Also the quantities $\partial_{\mu}J^{\mu}$, $J_{\mu}A^{\mu}$ and $\partial_{\mu}A^{\mu}$ are Lorentz invariants. (Why?) The latter, the frame independence of the divergence of the four potential, reflects the invariance of gauge choice. The gauge in which the expression is set to zero is called the *Lorentz gauge*.

Challenge 504

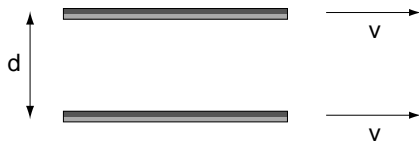

Figure 147 The relativistic aspect of magnetism

The argument is beautifully simple. We change the original experiment and imagine two long, electrically charged rods of mass m , moving in the same direction with velocity v and separation d . An observer moving with the rods would see an electrostatic repulsion between the rods given by

Challenge 521

$$ma_e = -\frac{1}{4\pi\epsilon_0} \frac{2\lambda^2}{d} \quad (336)$$

where λ is the charge per length of the rods. A second, resting observer sees two effects: the electrostatic repulsion and the attraction discovered by Ampère. He therefore observes

Challenge 538

$$ma_{em} = -\frac{1}{4\pi\epsilon_0} \frac{2\lambda^2}{d} + \frac{\mu_0}{2\pi} \frac{\lambda^2 v^2}{d} \quad (337)$$

It is easy to check that the second observer sees a repulsion, as the first one does, only if

$$v^2 < \frac{1}{\epsilon_0 \mu_0} \quad (338)$$

This maximum speed, with a value of 0.3 GM/s, is thus valid for any object carrying charges. But all everyday objects contain charges: there is thus a maximum speed for matter. Are you able to expand the argument to neutral particles as well? More on this limit velocity, which we know already, will be found out below.

Challenge 555

In summary, electric effects are due to flow of electric charges and to electric fields. Magnetism is due to *moving* electric charges. It is *not* due to magnetic charges. * The strength of magnetism, used in any running electric motor, proves relativity right: there is a maximum speed in nature. Both electric and magnetic fields carry energy and momentum. They are two faces of the same coin. However, our description of electromagnetism is not complete yet; we need the final description of the way charges *produce* the electromagnetic field.

The description of electromagnetic field evolution

In the years between 1861 and 1865, pondering the details of all experiments known to him, James Clerk Maxwell produced a description of electromagnetism which forms one of the pillars of physics. ** Maxwell took all experimental results and extracted their common basic principles, shown in Figures 148 and 149. Twenty years later, Heaviside and Hertz extracted the main points of Maxwell ideas and called the summary *Maxwell's theory of the electromagnetic field*. It consists of two equations (four in the nonrelativistic case).

See page 848

Challenge 572

* 'Electrons move in metal with a speed of about 1 mm; thus if I walk along a cable carrying a constant current with the same speed, I should not be able to sense any magnetic field.' What is wrong with the argument?

** James Clerk Maxwell (1831, Edinburgh–1879, Cambridge), scottish physicist; founded electromagnetism by unifying electricity and magnetism theoretically, as described in this chapter. His work on thermodynamics forms a second pillar of his activity. In addition, he also studied the theory of colours and developed the now standard horseshoe colour diagram; he was one of the first persons to make a colour photograph. He is often seen as the greatest physicist ever. Clerk and Maxwell were both his family names.

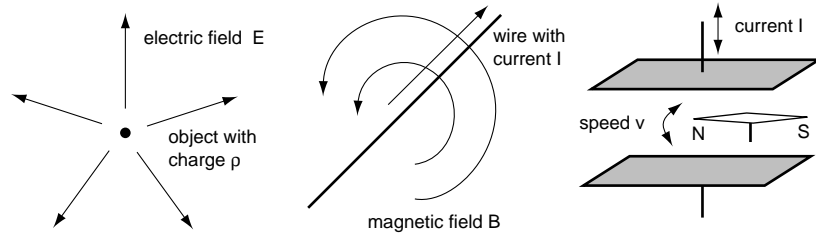

Figure 148 The first of Maxwell's equations

The first result is the precise description for the fact that electromagnetic fields *originate at charges*, and nowhere else. The corresponding equation is variously written*

$$dF = j\sqrt{\frac{\mu_0}{\epsilon_0}} \quad \text{or} \quad d^\nu F_{\mu\nu} = j^\mu\sqrt{\frac{\mu_0}{\epsilon_0}} \quad \text{or} \quad (339)$$

$$(\partial_t/c, -\partial_x, -\partial_y, -\partial_z) \begin{pmatrix} 0 & E_x/c & E_y/c & E_z/c \\ -E_x/c & 0 & -B_z & B_y \\ -E_y/c & B_z & 0 & -B_x \\ -E_z/c & -B_y & B_x & 0 \end{pmatrix} = \sqrt{\frac{\mu_0}{\epsilon_0}} (\rho, j_x/c, j_y/c, j_z/c) \quad \text{or}$$

$$\nabla \mathbf{E} = \frac{\rho}{\epsilon_0} \quad \text{and} \quad \nabla \times \mathbf{B} - \frac{1}{c^2} \frac{\partial \mathbf{E}}{\partial t} = \mu_0 \mathbf{j} \quad ,$$

putting into many signs a simple statement: *electrical charge carries the electromagnetic field*. This statement, including its equations, are equivalent to the three basic observations of Figure 148. It describes Coulomb's relation, Ampère's relation, and the way changing currents induce magnetic effects, as you may want to check.

Challenge 589

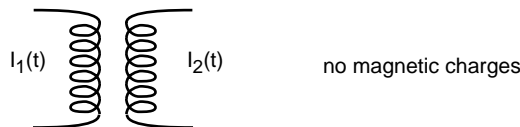

Figure 149 The second of Maxwell's equations

The second result by Maxwell is the precise description of how changing electric fields create magnetic fields, and vice versa. In particular, the electric field can have vortices only when there is a changing magnetic field. In addition it expresses the observation that in nature there are no magnetic charges, i.e. that magnetic fields have no sources. All these

* Maxwell generalized this equation to cases that the charges are not surrounded by vacuum, but located inside matter. We do not explore these situations in our walk; as we will see during our mountain ascent, the apparently special case of vacuum in fact describes all of nature.

results are described by the the relation variously written

$$\begin{aligned}
 d^*F = 0 \quad \text{with} \quad {}^*F^{\rho\sigma} = \frac{1}{2}\epsilon^{\rho\sigma\mu\nu}F_{\mu\nu} \quad \text{or} \\
 \epsilon_{\mu\nu\rho}\partial_\mu F_{\nu\rho} = \partial_\mu F_{\nu\rho} + \partial_\nu F_{\rho\mu} + \partial_\rho F_{\mu\nu} = 0 \quad \text{or} \\
 \begin{pmatrix} \gamma \frac{\partial}{\partial t} \\ \gamma \partial_x \\ \gamma \partial_y \\ \gamma \partial_z \end{pmatrix} \begin{pmatrix} 0 & B_x & B_y & B_z \\ -B_x & 0 & -E_z/c & E_y/c \\ -B_y & E_z/c & 0 & -E_x/c \\ -B_z & -E_y/c & E_x/c & 0 \end{pmatrix} = \begin{pmatrix} 0 \\ 0 \\ 0 \\ 0 \end{pmatrix} \quad \text{or} \quad (340) \\
 \nabla \mathbf{B} = 0 \quad \text{and} \quad \nabla \times \mathbf{E} = -\frac{\partial \mathbf{B}}{\partial t}
 \end{aligned}$$

The relation expresses the *lack of sources for the dual field tensor*, usually written *F . There are no magnetic charges, i.e. no magnetic monopoles in nature. In practice, one always needs this equation together with the previous one. Can you see why?

Challenge 606

We now have a system as organized as the expression $a = GM/r$ for gravitation. Together with Lorentz' evolution equation (334), which describes how charges move given the motion of the fields, Maxwell's evolution equations (340) and (341) describe *all* electromagnetic phenomena at everyday scales, from portable phones, car batteries, to personal computers, lasers, lightnings, holograms, and rainbows.

We will not study many applications of the equations in our mountain ascent; we continue directly towards our aim to understand the connection to everyday motion and to motion of light. In fact, the electromagnetic field has an important property which we mentioned already right at the beginning: it itself can also move.

The gauge field: the electromagnetic vector potential

The study of moving fields is called *field theory*, and electrodynamics is the major example. (The other classical example is fluid dynamics.) Field theory is a beautiful topic; field lines, equipotential lines, and vortex lines are some of the concepts introduced in this domain. They fascinate many.* However, in this mountain ascent we keep the discussion focussed on motion.

We have seen that fields force us to extend our concept of motion. Motion is not only the state change of objects and of space-time, but also the *state change of fields*. We therefore need, also for fields, a complete and precise description of their state. The observations with amber and magnets have shown us that *fields possess energy and momentum*, which they can impart to particles. The experiments with motors have shown that objects can add energy and momentum to fields. One therefore has to define a *state function* which allows to define energy and momentum for electric and magnetic fields.

Maxwell defined the state function in two standard steps. The first step is the definition of the (*magnetic*) *vector potential*, which describes the momentum per charge the field provides:

Ref. 13

Challenge 623 * What is the relation, for static fields, between field lines and (equi-) potential surfaces? Can a field line cross a potential surface twice?

For more details, see the *free* textbook by BO THIDÉ, *Electromagnetic Field Theory*, on his Ref. 1 <http://www.plasma.uu.se/CED/Book> web site. And of course, in English, the texts by Schwinger and by Ref. 9 Jackson.

$$\mathbf{A} = \frac{\mathbf{p}}{q} \quad (341)$$

When a charged particle moves through a magnetic potential $\mathbf{A}(\mathbf{x})$, its momentum changes by $q\mathbf{A}$. Due to this definition, the vector potential has the property that

$$\mathbf{B} = \nabla \times \mathbf{A} = \text{curl } \mathbf{A} \quad (342)$$

i.e. that the magnetic field is the curl of the magnetic potential.* For example, the vector potential for a long straight current carrying wire is parallel to the wire, and has the value

Challenge 640

$$A(r) = -\frac{\mu_0 I}{2\pi} \ln(r) \quad (343)$$

depending on the distance r from the wire. For a solenoid, the vector potential ‘circulates’ around it. Inside the solenoid, the vector potential increases from the centre. Similarly, for a constant and uniform magnetic field \mathbf{B} one finds the vector potential

$$\mathbf{A}(\mathbf{r}) = -\frac{1}{2} \mathbf{B} \times \mathbf{r} \quad (344)$$

However, there is a catch. The magnetic potential is *not* defined uniquely. If $\mathbf{A}(\mathbf{x})$ is a vector potential, then

$$\mathbf{A}'(\mathbf{x}) = \mathbf{A}(\mathbf{x}) + \text{grad } \Lambda \quad (345)$$

where $\Lambda(t, \mathbf{x})$ is some scalar function, is also a vector potential for the same situation. The magnetic field \mathbf{B} stays the same, though. What happens to the corresponding momentum values? They also change.

One is more accustomed to the fact that like momentum, also the energy of the electromagnetic field is defined ambiguously. Indeed, the second step in the specification of a state for the electromagnetic field is definition of the *electric potential* as the energy U per charge:

Ref. 13

$$\phi = \frac{U}{q} \quad (346)$$

In other words, the potential $\phi(\mathbf{x})$ at a point \mathbf{x} is the energy needed to move a unit charge to the point \mathbf{x} starting from a point where the potential vanishes. The potential energy is thus given by $q\phi$. Due to this definition, the electric field \mathbf{E} is simply the *change* of the potential with position corrected by the time dependence of momentum, i.e.

$$\mathbf{E} = -\nabla\phi - \frac{\partial}{\partial t} \mathbf{A} \quad (347)$$

* The curl is called the *rotation* and abbreviated *rot* in most languages.

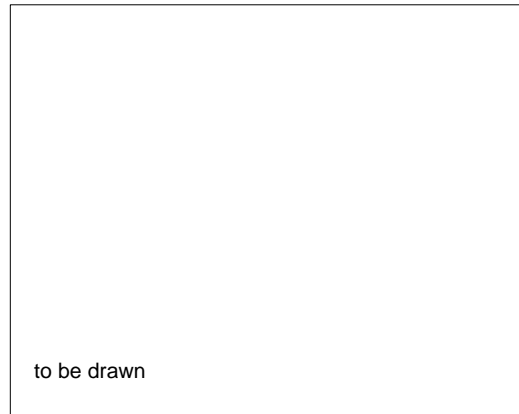

Figure 150 Vector potentials for selected situations

Obviously, there is a freedom in the choice of the definition of the potential. If $\varphi(\mathbf{x})$ is a possible potential, then

$$\varphi'(\mathbf{x}) = \varphi(\mathbf{x}) - \frac{\partial}{\partial t}\Lambda \quad (348)$$

is also a potential function for the same situation. This freedom is the generalization of the fact that energy is defined only up to a constant. Nevertheless, the electric field \mathbf{E} remains the same for all potentials.

In relativistic 4-vector notation, the state function of the electromagnetic field becomes

$$A^\mu = (\varphi/c, \mathbf{A}) \quad (349)$$

It is easy to see that it is a complete description of the field, since one has

$$\mathbf{F} = d\mathbf{A} \quad \text{or} \quad F^{\mu\nu} = \partial_\mu A_\nu - \partial_\nu A_\mu \quad (350)$$

which means that the electromagnetic field is completely specified by the 4-potential A . But as just said, the 4-potential itself is *not* uniquely defined. Indeed, any other gauge field A' related to A by the *gauge transformation*

$$A'^\mu = A^\mu + \partial^\mu \Lambda \quad (351)$$

where $\Lambda = \Lambda(t, x)$ is any arbitrarily chosen scalar field, leads to the *same* electromagnetic field, and to the same accelerations and evolutions. The gauge 4-field A is thus an *overdescription* of the physical situation as several *different* A correspond to the *same* physical situation. Therefore one has to ensure that all measurement results are independent of gauge transformations, i.e. that all observables are gauge invariant quantities. Such gauge invariant quantities are, as we just saw, the fields \mathbf{F} and *F , and in general all classical quantities. We note that many theoretical physicists use the term 'electromagnetic field' for the quantity A_μ .

There is a simple image, due to Maxwell, to help overcoming the conceptual difficulties of the vector potential. It turns out that the closed line integral over A_μ is gauge invariant, because

$$\oint A_\mu dx^\mu = \oint (A_\mu + \partial_\mu \Lambda) dx^\mu = \oint A'_\mu dx^\mu \quad (352)$$

Challenge 657

In other words, if one pictures the vector potential as a quantity allowing to associate a number to a tiny ring at each point in space, one gets a good, gauge invariant picture of the vector potential.*

Now that we have defined a state function which describes energy and momentum, let us see what happens in more detail when electromagnetic fields move.

Colliding charged particles

A simple experiment clarifies the just defined properties of electromagnetic fields. When two charged particles collide, one finds that their total momentum is *not* conserved.

Ref. 14 * In the part on quantum mechanics we will see that the exponent of this expression, namely $\exp(iq \oint A_\mu dx^\mu)$, usually called the *phase factor*, can indeed be directly observed in experiments.

Imagine two particles of identical mass and charge just after a collision, when they move away from each other. Imagine also that the two masses are large, so that the acceleration due to their electrical repulsion is small. For an observer in the centre of gravity of the two, each particle feels an acceleration from the electrical field of the other, given by the so-called *Heaviside formula*

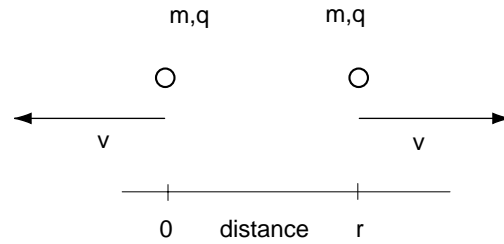

Figure 151 Charged particles after a collision

$$E = \frac{q(1 - v^2/c^2)}{4\pi\epsilon_0 r^2} \quad (353)$$

In other words, the total system has a vanishing total momentum.

Take a second observer, moving with respect to the first with velocity v , so that the first charge will be at rest. The expression of the electrical field leads to two different values for the electric fields at the position of each particle. In other words, the system of the two particles is not in inertial motion, as we would expect; the total momentum is not conserved.

Ref. 15

Where did it go?

Challenge 691

This at first surprising effect has even been put in form of a theorem, by Van Dam and Wigner. They showed that for a system of particles interacting at a distance the total energy-momentum cannot remain constant in all inertial frames.

Ref. 16

The total momentum of the system is conserved only because the electromagnetic field itself also carries momentum. In other words, electromagnetic fields are able to *hit* objects and to be hit by them. As we will show below, also light is an electromagnetic field. Thus one should be able to move objects by shining light onto them. One should even be able to suspend particles in mid air by shining light onto them from below. Both predictions are correct, and a few experiments describing them will be presented shortly.

One concludes that any sort of field leading to particle interactions must carry energy and momentum, as the argument applies to all such cases. In particular, it applies to the nuclear interactions. Indeed, in the second part of our mountain ascent we will even find an additional result: all fields are themselves composed of particles. The energy and momentum of fields then become an obvious state of affairs.

The Lagrangian of electromagnetism

The motion of charged particles and the motion of the electromagnetic field can also be described using a Lagrangian instead of using the three equations given above. It is not hard to see that the action S_{CED} for a particle in classical electrodynamics can be symbolically defined by*

Challenge 708

$$S_{CED} = -mc^2 \int d\tau - \frac{1}{4\mu_0} \int F \wedge *F - \int j \wedge A \quad (354)$$

*The symbol \wedge , 'wedge', in fact has a precise mathematical meaning; but its background, the concept of (*mathematical*) form, carries us too far from our walk. An electrodynamics text completely written with forms is KURT MEETZ & WALTER L. ENGL, *Elektromagnetische Felder – Mathematische und physikalische Grundlagen*, Springer, 1980.

which in index notation becomes

$$S_{\text{CED}} = -mc \int_{-\infty}^{\infty} \sqrt{\eta_{\mu\nu} \frac{dx_n^\mu(s)}{ds} \frac{dx_n^\nu(s)}{ds}} ds - \int_{\mathbf{M}} \left(\frac{1}{4\mu_0} F_{\mu\nu} F^{\mu\nu} + j_\mu A^\mu \right) d^4x .$$

In other words, the least action principle still states that the change of a system is always as small as possible. New is the measure of the change produced by the electromagnetic field. Its internal change is given by the term FF , and the change due to interaction with matter is given by the term jA .

The action S_{CED} leads to the evolution equations by requiring that it be stationary under variations δ, δ' of the positions and of the fields which vanish at infinity, i.e. that

$$\begin{aligned} \delta S = 0 \quad & \text{when } x_\mu = x_\mu + \delta_\mu \quad \text{and} \quad A_\mu = A_\mu + \delta'_\mu , \\ & \text{provided } \delta x_\mu(\theta) \rightarrow 0 \quad \text{for } |\theta| \rightarrow \infty \\ & \text{and } \delta A_\mu(x_\nu) \rightarrow 0 \quad \text{for } |x_\nu| \rightarrow \infty . \end{aligned} \quad (355)$$

In the same way as in the case of mechanics, using the variational method for the two variables A and x , one recovers the evolution equations for particle and fields

See page 119
Challenge 725

$$b^\mu = \frac{q}{m} F_\nu^\mu u^\nu , \quad \partial_\mu F^{\mu\nu} = j^\nu \sqrt{\frac{\mu_0}{\epsilon_0}} , \quad \text{and} \quad \epsilon^{\mu\nu\rho\sigma} \partial_\nu F_{\rho\sigma} = 0 \quad (356)$$

which we know already. Obviously, they are equivalent to the variational principle based on S_{CED} . Both descriptions have to be completed by specifying *initial conditions* for the particles and the fields, as well as *boundary conditions* for the latter. One needs the first and zeroth derivatives of the position of the particles, and the zeroth derivative for the electromagnetic field.

Are you able to specify the Lagrangian of the pure electrodynamic field using the fields \mathbf{E} and \mathbf{B} ?

Challenge 742

Note that this result also implies that electromagnetism is *time reversible*. That means that every example of motion due to electric or magnetic causes can also take place backwards. This is easily deduced from the properties of the Lagrangian. On the other hand, everyday life shows many electric and magnetic effects which are not time invariant, such as electromagnetic braking, electric light bulbs, etc. Can you explain how this fits together?

Challenge 759

In summary, with Lagrangian (354) all of classical electrodynamics is described and understood. For the rest of this chapter, we look at some specific topics from this vast field.

Symmetries: the energy-momentum tensor

We know from classical mechanics that we get the definition of energy and momentum tensor by using Noether's theorem, if we determine the conserved quantity from the Lorentz symmetry of the Lagrangian. For example, we found that relativistic particles have an energy-momentum *vector*. At the point at which the particle is, it describes the energy and momentum.

Since the electromagnetic field is not a localized entity like a point particle, but extended, one needs to know the *flow* of energy and momentum at each point, separately *for each direction*. This makes a description with a *tensor* necessary.

– CS – to be continued – CS –

In summary, electrodynamic motion, like all other examples of motion encountered so far, is deterministic, is conserved, and is reversible. No big news. But two special symmetries of electromagnetism deserve special mention.

What is a mirror?

We will study the strange properties of mirrors several times during our walk. We start with the simplest one first. Everybody can observe, by painting his hands in two different colours, that a mirror does *not* exchange right and left, as little as it exchanges up and down; however, a mirror does exchange right and left *handedness*. In fact, it does so by exchanging front and back.

Challenge 776

Electrodynamics give a second answer: a mirror is a device that switches magnetic north and south poles. Can you confirm this?

But is it always possible to distinguish left from right? This seems easy: this text is rather different from a *bærrinn* version, as are many other objects in our surroundings. But take a simple landscape. Are you able to say which of the two pictures of Figure 152 is the original?

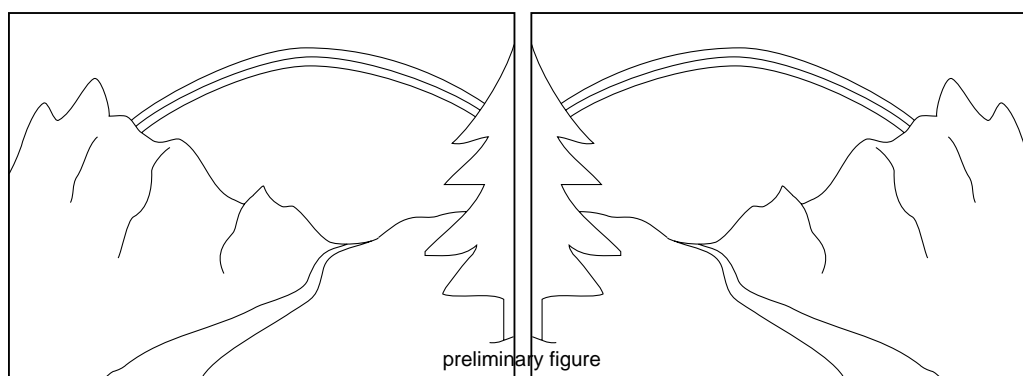

Figure 152 Which one is the original landscape?

Astonishingly, it is actually impossible to distinguish a picture of nature from its mirror image if it does not contain any human traces. In other words, everyday nature is somehow left-right symmetric. This observation is so common that all candidate exceptions, from the jaw movement of ruminating cows to the helical growth of plants, have been studied extensively.* Can you name a few more?

See page 624

Challenge 793

Ref. 17

* The most famous is the position of the heart. The mechanisms leading to this disposition are still being investigated. Most recent research is suggesting that the oriented motion of the cilia on embryos, probably in the region called *node*, determine the right left asymmetry. The deep origin of this asymmetry is not yet elucidated, however.

Another asymmetry of the human body is the hair whirl on the back of the head; the majority of humans having only one, and in 80% of the cases it is left turning.

The left-right symmetry of nature is a consequence of the fact that everyday nature is described by gravitation and, as we will see, by electromagnetism. Both interactions share an important property: by substituting all coordinates in their equations by the negative of their values the equations remain unchanged. This means that for any solution of these equations, i.e. for any naturally occurring system, the mirror image is also a possibility which can occur naturally. Everyday nature thus cannot distinguish between right and left. Indeed, there are right *and* left handers, people with their heart on the left *and* others with their heart on the right side, etc.

To explore further this strange aspect of nature, try the following experiment: imagine you are exchanging radio messages with a martian; are you able to explain him what right and left are, so that when you will meet, you are sure you are talking about the same thing?

Challenge 810

Actually, the mirror symmetry of everyday nature – also called its *parity invariance* – is so pervasive that most animals cannot even distinguish left from right in a deeper sense. Most animals react to mirror stimuli with mirror responses. It is hard to teach them different ways to react, and it is possible almost only for mammals. The many experiments performed on this topic gave the result that animals have symmetrical nervous systems, and possibly only humans show *lateralization*, i.e. a preferred hand and a different use for the left and the right part of the brain.

Ref. 18

To sum up this digression, classical electrodynamics is left-right symmetric, or parity invariant. Can you show this using its Lagrangian?

Challenge 827

What is the difference between electric and magnetic fields?

Obviously, the standard answer is that electric fields have sources, and magnetic fields do not; that moreover magnetic fields are small relativistic effects of importance only when charge velocities are high or when electrical fields cancel out.

For situations with matter, this clear distinction is correct. Up to the present day, no particle with a magnetic charge, called a *magnetic monopole*, has ever been found, even though its existence is possible in several unified models of nature. If found, the action (354) would have to be modified by the addition of a fourth term, namely the magnetic current density. However, no such particle has yet been detected, despite intensive search efforts.

See page 628

But in vacuum, when matter is not around, it is possible to take a completely different view. In vacuum the electric and the magnetic field can be seen as two faces of the same quantity, since a transformation such as

$$\begin{aligned}\mathbf{E} &\rightarrow c\mathbf{B} \\ \mathbf{B} &\rightarrow -\mathbf{E}/c\end{aligned}\quad (357)$$

called (electromagnetic) *duality* transformation, transforms each vacuum Maxwell equation into the other. (In fact, there are even more such transformations; can you spot them?) Alternatively, the duality transformation transforms \mathbf{F} into ${}^*\mathbf{F}$. In other words, in vacuum one *cannot* distinguish electric from magnetic fields.

Challenge 844

Matter would be symmetric under duality only if magnetic charges, also called magnetic monopoles, would exist. In that case the transformation (357) could be extended to

$$c\rho_e \rightarrow \rho_m \quad , \quad \rho_m \rightarrow -c\rho_e \quad . \quad (358)$$

It was one of the great discoveries of theoretical physics that even though classical electrodynamics with matter is not symmetric under duality, nature is. In 1977, Claus Montonen and David Olive showed that quantum theory allows duality transformations even *with* the inclusion of matter. It was already known since the 1930s that quantum theory allows magnetic monopoles. We will discover the important ramifications of this result in the third part of the text. This duality turns out to be one of the essential stepping stones leading to a unified description of motion. (A somewhat difficult question: Extending this duality to quantum theory, can you deduce what transformation is found for the fine structure constant, and why it is so interesting?)

See page 640

Challenge 861

Duality, by the way, is a symmetry that works *only* in Minkowski space-time, i.e. in space-times of 3 plus 1 dimensions. Mathematically, it is closely related to the existence of quaternions, to the possibility of interpreting Lorentz boosts as rotations in 3+1 dimensions, and last but not least, to the possibility to define other smooth mathematical structures than the standard one on the space R^4 . These mathematical connections are still somewhat mysterious at the time being; they somehow point to the special role that four space-time dimensions play in nature. More details will become clear in the third part of our mountain ascent.

14. What is light?

An important consequence of the equations of electrodynamics was deduced by Maxwell in 1865. He found that in the case of vacuum, the equations of the electrodynamic field could be written as

$$\square \mathbf{A} = 0 \quad \text{or} \quad \epsilon_0 \mu_0 \frac{\partial^2 \varphi}{dt^2} + \frac{\partial^2 A_x}{dx^2} + \frac{\partial^2 A_y}{dy^2} + \frac{\partial^2 A_z}{dz^2} = 0 \quad . \quad (359)$$

Challenge 878 This is called a *wave equation*, because it admits solutions of the type

$$\mathbf{A}(t, x) = \mathbf{A}_0 \sin(\omega t - \mathbf{kx} + \delta) \quad (360)$$

which are commonly called (*plane*) *waves*. Such a wave satisfies equation (359) for any value of the *amplitude* A_0 , of the *phase* δ , and of the *angular frequency* ω , provided the *wave vector* \mathbf{k} satisfies the relation

$$\omega(\mathbf{k}) = \frac{1}{\sqrt{\epsilon_0 \mu_0}} k \quad \text{or} \quad \omega(\mathbf{k}) = \frac{1}{\sqrt{\epsilon_0 \mu_0}} \sqrt{\mathbf{k}^2} \quad (361)$$

The relation $\omega(\mathbf{k})$ between the angular frequency and the wave vector, the so-called *dispersion relation*, is the main property of any type of wave, be it a sound wave, a water wave, an electromagnetic wave, or any other kind. Relation (361) specifically characterizes electromagnetic waves in vacuum, and distinguishes them from all other types of waves. *

Equation (359) for the electromagnetic field is *linear* in the field; this means that the sum of two situations allowed by it is itself an allowed situation. Mathematically speaking, any *superposition* of two solutions is a solution as well. For example, this means that

* Just to be complete, a *wave* in physics is any propagating imbalance. Other types of waves, such as sound, water waves, earthquakes, etc., will not be studied much in this mountain ascent.

two waves can travel through each other without disturbing each other, and that waves can travel through static electromagnetic fields. Linearity also means that any electromagnetic wave can be described as a superposition of pure sine waves, each of which is described by expression (360).

After Maxwell had predicted the existence of electromagnetic waves, in the years between 1885 and 1889 Heinrich Hertz* discovered and studied them, by fabricating a very simple transmitter and receiver for 2 GHz waves. Waves around this frequency are used in the last generation of mobile telephones. These waves are now called *radio waves*, since physicists tend to call all moving force fields *radiation*, recycling an old term which originally meant ‘light emission.’

Hertz also measured the speed of these waves; today everybody can do that by himself by telephoning to a friend on another continent using a satellite line (just use a low cost provider). There is about half a second additional delay between the end of a sentence and the answer of the friend, compared to normal conversation. In this half second, the signal goes up to the geostationary satellite, down again and back. This gives a speed of $c \approx 4 \cdot 36\,000 \text{ km} / 0.5 \text{ s} \approx 3 \cdot 10^5 \text{ km/s}$, which is close to the precise value.

But Maxwell did more. He also predicted that *light* itself is a solution of equation (360) and therefore an electromagnetic wave, albeit with a much higher frequency. This famous prediction can be checked in many ways.

It is easy to confirm the *wave* properties of light, and indeed they were known already long before Maxwell. In fact, the first to suggest that light is a wave was, around the year 1678, the important Dutch physicist Christiaan Huygens (1629, ‘s Gravenhage –1695, Hofwyck). One can confirm this fact with one’s own fingers. Simply put your hand one or two centimetres from the eye, look towards the sky through the gap between the middle finger and the index, and let the two fingers almost touch. You will see a number of dark lines dividing the gap. These lines are the interference pattern formed by the light behind the slit created by the fingers. *Interference* is the name given to those amplitude patterns which appear when several waves superpose.** This experiment therefore also allows to estimate the wavelength of light, and thus if you know its speed, also its frequency. Are you able to do so?

Challenge 912

Historically, a similar effect was central in convincing everybody that light was a wave: the supernumerary rainbows, the additional bows below the main rainbow. If one looks carefully at a rainbow, below the main red yellow green blue violet bow, one observes weaker, additional green blue and violet bows. Depending on the intensity of the rainbow, several of these supernumerary rainbows can be observed. They are due to an interference effect, as Thomas Young showed around 1803.*** (More about the rainbow below.) It seems

Ref. 19

See page 372

* Heinrich Rudolf Hertz (1857, Hamburg–1894, Bonn), important hamburger theoretical and experimental physicist. The unit of frequency is named after him. Despite his early death, Hertz was a central figure in the development of electromagnetism, in the explanation of Maxwell’s theory, and in the unfolding of radio communication technology. More about him on page 107.

Challenge 895

** Where does the energy go in interference patterns?

*** Thomas Young (1773, Milverton–1829), read the bible at two, spoke Latin at four; doctor of medicine, he became professor of physics. He introduced the concept of *interference* into optics, explaining the Newtonian rings and rainbow, and was the first person to determine light’s *wavelength*, a concept that he also introduced, and its dependence on colour. He was the first to deduce the three colour vision explanation of the eye and after reading of the discovery of polarization, explained light as a transverse wave. In short he discovered most what people learn at high school about light. He was a universal talent: he also worked on the deciphering of

that in those times scientists either did not trust their own fingers, or did not have any.

There are many other ways that the wave character of light becomes apparent. Maybe the most beautiful is an experiment carried out by a team of Dutch physicists in 1990. They simply measured the light transmitted through a *slit* in a metal plate. It turns out that the transmitted intensity depends on the width of the slit. Their surprising result is shown in Figure 153. Can you explain the origin of the unexpected steps in the curve?

Ref. 20

Challenge 929

Numerous other experiments on the creation, detection, and measurement of electromagnetic waves have been performed in the nineteenth and twentieth century. For example, in 1800, William Herschel discovered infrared using a prism and a thermometer. A bit later, Johann Wilhelm Ritter, a colourful figure of natural Romanticism, discovered ultraviolet light, using silver chloride, AgCl , and a prism again. The result of all these experiments is that electromagnetic waves can be distinguished first of all by their frequency or wavelength. The main categories are listed in Table 35.

Challenge 946

See page 366

At the end of the twentieth century the final confirmation has become possible. Using quite sophisticated experiments it became possible to measure the oscillation frequency of light directly. The value, between 375 and 750 THz, is so high that detection was impossible for many years. But with these modern experiments the dispersion relation (361) of light has finally been confirmed completely.

Ref. 21

So far, we avoided one question about light. If light oscillates, in which direction does this happen? The answer is hidden in the parameter \mathbf{A}_0 in expression (360). Electromagnetic waves oscillate in directions *perpendicular* to their motion. Therefore, even for identical frequency and phase, waves can still differ: they can have different *polarization* directions. For example, the polarization of radio transmitters determine whether radio antennas of receivers have to be kept horizontal or vertical. Also for light, polarization is easily achieved, e.g. by shining it through stretched plastic films. When the polarization of light was discovered in 1808 by the French physicist Louis Malus, it definitively established its wave nature. Malus discovered it when he looked at the strange double images produced by feldspat, a transparent crystal found in many minerals. Feldspat splits light beams into two, it is *birefringent*, and polarizes them differently. That is the reason that feldspat is part of every crystal collection. If you ever see a piece of feldspat, have a look at it.

By the way, the human eye is unable to detect polarization, in contrast to many insects. As is well known honey bees use polarization to deduce the position of the sun even when

hieroglyphs, on ship building, and on engineering problems. In Britain his ideas on light were not accepted, since Newton's followers crushed all opposing views. Young collaborated with Fraunhofer and Fresnel; at last, his results were made famous by Fresnel and Helmholtz.

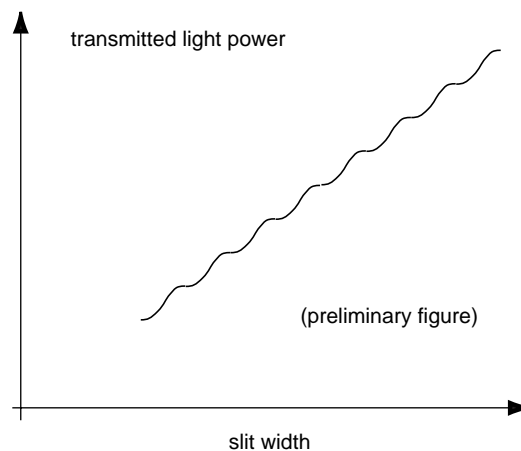

Figure 153 The light power transmitted through a slit as function of its width

(Can you guess how?) A bit later, Johann Wilhelm Ritter, a colourful figure of natural Romanticism, discovered ultraviolet light, using silver chloride, AgCl , and a prism again. The result of all these experiments is that electromagnetic waves can be distinguished first of all by their frequency or wavelength.

it is hidden behind clouds, and many insects use polarization to distinguish water surfaces from mirages. Can you find out how? On the other hand, both the cornea and the lens of the human eye are birefringent.

Ref. 22
Challenge 963
Ref. 23

Note that all possible polarizations of light form a continuous set. However, a general wave can be seen as a superposition of two orthogonal, linearly polarized waves with different amplitudes and different phases. Most books show pictures of plane, linearized electrodynamic waves. Essentially, the electric fields look like water waves generalized to three dimensions, the same for magnetic fields, and the two are perpendicular to each other. Can you confirm this?

Challenge 980

Interestingly, a generally polarized plane wave can also be seen as the superposition of right and left *circularly polarized waves*. However, no figures of such waves are found in any textbook. Can you explain why?

Challenge 997

So far it is clear that light is a wave. To confirm that the nature of light is indeed *electromagnetic* is more difficult. The first argument was by Maxwell. From equation (361), he deduced a prediction for the speed of electromagnetic waves, namely the celebrated expression

$$c = \frac{1}{\sqrt{\epsilon_0 \mu_0}} \quad (362)$$

which you should be able to confirm. When Maxwell inserted the values in the right hand side, he found, within measurement errors, complete correspondence with the measured speed of light. Note that the right hand side contains electric and magnetic quantities, and the left hand side is an optical entity. The expression thus unifies electromagnetism with optics.

Challenge 1014

Of course, people were not yet completely convinced. They looked for more ways to show that light is electromagnetic in nature. Since Maxwell's evolution equations are linear, electric or magnetic fields alone do not influence the motion of light. On the other hand, since electromagnetic waves are emitted only by accelerated charges, and since all light is emitted from matter, one follows that matter is full of electromagnetic fields and accelerated electric charges. This implies that the influence of matter on light could be understood from its internal electromagnetic fields, and in particular, that subjecting matter to *external* electromagnetic fields should change its the light it emits, the way it interacts with light, or generally, the material properties as a whole.

For example, it is indeed found that electric fields can influence the light transmission of oil, an effect discovered by Kerr. With time, many more influences of matter in fields on light were found, and a more extensive list is given in the table on page 392. It turns out that with a few exceptions the effects can *all* be described by the electromagnetic Lagrangian S_{CED} (354), or equivalently, by Maxwell's equations (356). In summary, classical electrodynamics indeed unifies the description of electricity, of magnetism, and of optics; all phenomena in these fields, from the rainbow to radio, from lightnings to electric motors, are found to be different aspects of the evolution of the electromagnetic field F .

Table 35 The electromagnetic spectrum

Frequency	Wave-length	Name	Main properties	Appearance	Use
$3 \cdot 10^{-18}$ Hz	10^{26} m	lower frequency limit		see section on cosmology	
< 10 Hz	> 30 Mm	quasistatic fields		intergalactic, galactic, stellar, and planetary fields, brain, electrical fish	power transmission, accelerating and deflecting cosmic radiation
		radio waves		electronic devices	
10 Hz-50 kHz	30 Mm-6 km	ELW	go round the globe, penetrate into water	nerve cells, electromechanical devices	power transmission, communication with submarines www.vlf.it
50 -500 kHz	6 km-0.6 km	LW	follow earth curvature, felt by nerves ('bad weather nerves')	emitted by thunderstorms	radio communications, telegraphy, inductive heating
500 -1500 kHz	600 m-200 m	MW	reflected by night sky		radio
1.5 -30 MHz	200 m-10 m	SW	circle world if reflected by the ionosphere, destroy hot air balloons	emitted by stars	radio transmissions, radio amateurs, spying
15 -150 MHz	20 m-2 m	VHF	allow battery operated transmitters		remote controls, closed networks, tv, radio amateurs, radio navigation, military, police, taxi
150 -1500 MHz	2 m-0.2 m	UHF	idem, line of sight propagation		radio, walkie-talkies, tv, cellular phones, internet via cable, satellite communication, bicycle speedometers
		microwaves			
1.5 -15 GHz	20 cm-2 cm	SHF	idem, absorbed by water	night sky, emitted by hydrogen atoms	radio astronomy, used for cooking (2.45 GHz), telecommunications, radar
15 -150 GHz	20 mm-2 mm	EHF	idem, absorbed by water		
		infrared	go through clouds	emitted by every warm object	satellite photography of earth, astronomy
3 -100 THz	1000 -3 μ m	IRC or far infrared		sunlight	
100 -210 THz	3 μ m-1.4 μ m	IRB or medium infrared		sunlight	used for optical fibre communications for telephone and cable TV

Frequency	Wave-length	Name	Main properties	Appearance	Use
210 -385 THz	1400-780 nm	IRA or near infrared	penetrates for several cm into human skin	sunlight, radiation from hot bodies	healing of wounds, rheumatism, sport physiotherapy, hidden illumination
375 -750 THz	800-400 nm	light	not absorbed by air, detected by the eye (up to 850 nm at sufficient power)	heat ('hot light'), lasers & chemical reactions e.g. phosphor oxidation, fireflies ('cold light')	definition of straightness, enhancing photosynthesis in agriculture, photodynamic therapy, hyperbilirubinaemia treatment
375 -478 THz	780-627 nm 700 nm	red pure red	penetrate flesh	blood rainbow	alarm signal, used for breast imaging colour reference for printing, painting, illumination and displays
478 -509 THz	627-589 nm 600 nm	orange standard orange		various fruit	attracts birds and insects
509 -530 THz	589-566 nm 580 nm	yellow standard yellow		majority of flowers	idem; best background for reading black text
530 -606 THz	566-495 nm 546.1 nm	green pure green	maximum eye sensitivity	algae and plants rainbow	highest brightness per light energy to the human eye colour reference
606 -688 THz	495-436 nm 488 nm 435.8 nm	blue standard cyan pure blue		sky, gems, water rainbow	colour reference
688 -789 THz	436-380 nm	indigo, violet		flowers, gems	
ultraviolet					
789 -952 THz	380-315 nm	UVA	penetrate ca. 1 mm into skin, darken it, produce vitamin D, suppress immune system, cause skin cancer, destroy eye lens	emitted by sun and stars	seen by certain birds, integrated circuit fabrication
0.95 - 1.07 PHz	315-280 nm	UVB	idem, destroy DNA, cause skin cancer	idem	idem

Frequency	Wave-length	Name	Main properties	Appearance	Use
1.07 -3.0 PHz	280-100 nm	UVC	form oxygen radicals from air, kill bacteria, penetrate ca. 10 μ m into skin	idem	disinfection, water purification, waste disposal, integrated circuit fabrication
3 -24 PHz	100-13 nm	EUV			sky maps, silicon lithography
		X-rays	penetrate materials	emitted by stars, plasmas, and black holes	imaging human tissue
24 -240 PHz	13-1.3 nm	soft X-rays	idem	synchrotron radiation	idem
> 240 PHz or > 1 keV	< 1.2 nm	hard X-rays	idem	emitted when fast electrons hit matter	crystallography, structure determination
> 12 EHz or > 50 keV	< 24 pm	γ -rays	idem	radioactivity, cosmic rays	chemical analysis, disinfection, astronomy
$1.9 \cdot 10^{43}$ Hz	$\approx 10^{-35}$ m	Planck limit		see part three of this text	

The expression of the speed of light does not depend on the proper motion of the observer measuring the electromagnetic fields involved. This strange result was the first hint that the speed of light is a universal constant. However, it took several decades before the consequences we realized and relativity was developed.

As a note, it is often told that the teenager Albert Einstein asked himself what would happen if an observer would move at the speed of light, and in particular, what kind of electromagnetic field he would observe. He once explained that this Gedankenexperiment convinced him already at that young age that *nothing* could travel at the speed of light, since the field observed would have a property not found in nature. Can you guess which one?

Challenge 1031

Does light travel straight?

Usually this is the case, since we even use light to *define* 'straightness.' However, there are a few exceptions and every expert on motion should know them.

Ref. 24

In sugar syrup, light beams curve, as shown in Figure 154. In fact, light bends at any material interface. This effect, called *refraction*, is the same that makes aquaria seem less deep than they actually are. Refraction is a consequence of the change of light speed from material to material.

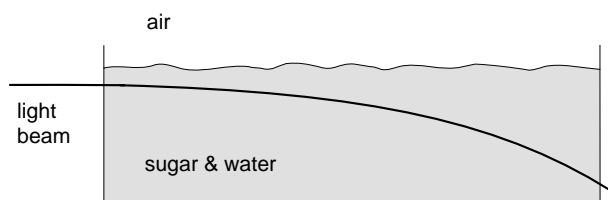

Figure 154 Sugar water bends light

Challenge 1048

Are you able to explain refraction, and thus explain the syrup effect?

Refraction in water droplets is also the basis of the rainbow, as shown on page 372, and refraction in ice crystals in the atmosphere is at the basis of the halos and the many other light patterns often seen around the sun and the moon.

Ref. 25

A second important observation is that light goes around corners, and the more so the more they are sharp. This effect is called *diffraction* and is also due to the wave nature of light. You probably remember it from high school. In fact, light goes around corners in the same way that sound does.

Because of diffraction, it is impossible to produce strictly parallel light beams. For example, every laser beam diverges by a certain minimum amount, called the *diffraction limit*. Maybe you know that the world's most expensive cat-eye is on the moon, where it has been deposited by the Apollo 11 cosmonauts. Can you determine how wide a laser beam with minimum divergence has become when it arrives at the moon, assuming that it was 1 m wide when sent to the moon? How wide would it come back if it had been 1 mm wide at the start?

Ref. 26

Challenge 1065

Diffraction implies that there are no perfectly sharp images: there exists a *limit on resolution*. This is true for the eye as well, where the resolution is between one and two minutes of arc, i.e. between 0.3 and 0.6 mrad. The limit is due to the limited size of the pupil. Therefore for example, there is a maximum distance at which one can distinguish the two headlights of a car. Can you estimate it?

Challenge 1082

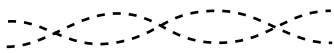

Preliminary drawing

Figure 155 Light beams can spiral around each other

For the same reason it is impossible to see the Great Wall in northern China from the moon, contrary to what is often claimed. In the few parts which are not yet in ruins, the wall is about 6 metres wide, and even if it casts a wide shadow during the morning or the evening, the angle it subtends is way below a second of arc, so that it is completely invisible to the human eye. In fact, three different cosmonauts who went to the moon performed careful searches and confirmed that the claim is absurd. The story is one of the most tenacious urban legends. (Is it possible to see the wall from the space shuttle?) In fact the largest man-made objects are the polders of reclaimed land in the Netherlands; they *are* visible from outer space. So are most large cities as well as the highways in Belgium at night; their bright illumination makes them stand out clearly from the dark side of the earth.

Ref. 27

Challenge 1099

Diffraction also means that behind a small disk illuminated along its axis, the centre of the shadow shows, against all expectations, a bright spot. This spot was predicted in 1819 by Denis Poisson in order to show to what absurd consequences the wave theory of light would lead. He had just read the mathematical description of diffraction developed by Augustin Fresnel on the basis of the wave description of light. But shortly afterwards, François Arago* actually observed Poisson's point, making Fresnel famous, and the wave properties of light started to be generally accepted.

Electromagnetic fields do not influence light directly, since light has no charge, and since Maxwell's equation are linear. But in some materials the equations are non-linear, and the

* François Arago (1786–1853), French physicist. Augustin Jean Fresnel (1788–1827), engineer and part time physicist; he published in 1818 his great paper on wave theory for which he got the price of the French academy of sciences in 1819. To improve his finances, he worked in the commission responsible for lighthouses, for which he developed the well-known Fresnel lens. He died prematurely, partly of exhaustion due to overwork.

story changes. For example, in certain photorefractive materials, two nearby light beams can even *twist* around each other, as shown by Segev and coworkers in 1997.

Ref. 28

A final way to bend light is gravity, as discussed already in the chapters on universal gravity and on general relativity. Also the effect of gravity between two light beams was discussed there.

See page 308

In summary, light travels straight only if it travels *far from other matter*. In everyday life, ‘far’ simply means more than a few millimetres, because all gravitational and electromagnetic effects are negligible at these distances, mainly due to lights’ truly super-sonic speed.

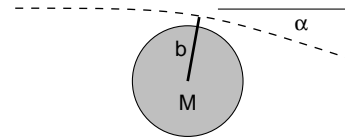

Figure 156 Masses bend light

Can one touch light?

If one takes a little glass bead and poses it on top of a powerful laser, the bead remains suspended in mid air, as shown in Figure 157. That means that light has momentum. Therefore, contrary to what we said in the beginning of our mountain ascent, images *can* be touched! In fact, the ease with which objects can be pushed has even a special name. For stars, it is called the *albedo*, and for general objects it is called the *reflectivity r*.

Like each type of electromagnetic field, and like every kind of wave, light carries energy; the energy flow per surface and time

Challenge 1116 is

$$\mathbf{P} = \frac{1}{\mu_0} \mathbf{E} \times \mathbf{B} \quad \text{giving an average} \quad \langle P \rangle = \frac{1}{2\mu_0} E_{\max} B_{\max} \quad (363)$$

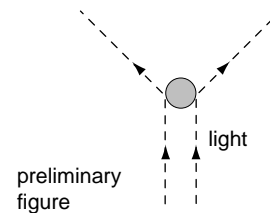

Figure 157 Levitating a small glass bead with a laser

Obviously, light also has momentum. It is related to the energy by

$$p = \frac{E}{c} \quad (364)$$

Challenge 12 As a result, the pressure *p* exerted by light onto a body is given by

$$p = \frac{P}{c} (1 + r) \quad (365)$$

where for black bodies one has *r* = 0 and for mirrors *r* = 1; other bodies have values in between. What is your guess for the amount of pressure due to sunlight on a black surface of one square metre? Is that the reason that we feel more pressure during the day than during the night?

Challenge 29

In fact, one needs rather delicate equipment to detect the momentum of light, or if one prefers, its radiation pressure. In order to achieve this, in 1873, William Crookes * invented the *light mill radiometer*. He had the intention to demonstrate the radiation pressure of light. The light mill consists of four thin plates, black on one side and shiny on the other, which

Ref. 29

* William Crookes (1832, London–1919, London), English chemist and physicist, president of the Royal Society, discoverer of Thallium.

are mounted on a vertical axis, as shown in Figure 158. However, when Crookes finished building it – it was similar to those sold in shops today – he found, like everybody else, that it turned in the wrong direction, namely with the shiny side towards the light! (Why is it wrong?) You can check it by yourself by pointing a laser pointer onto it. The behaviour has been a puzzle for quite some time. Explaining it involves the tiny amount of gas left over in the glass bulb and takes us too far from the topic of our mountain ascent. Only in 1901, with the advent of much better pumps, it was possible to create a sufficiently good vacuum that allowed to measure the light pressure with such an improved, true radiometer.

Challenge 46

Ref. 30

Ref. 31

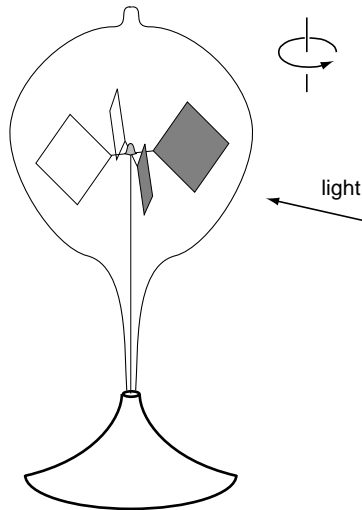

Figure 158 A commercial light mill turns *against* the light

them apart with such an optical tweezer.

But that is not all. In the last decade of the twentieth century, several groups even managed to *rotate* objects, thus realizing actual *optical spanners*. They are able to rotate particles at will in one direction or the other, by changing the optical properties of the laser beam used to trap the particle.

Challenge 63

Ref. 32

Ref. 32

In fact, it does not take much to deduce that if light has linear momentum, circularly polarized light also has *angular* momentum. In fact, for such a wave the angular momentum L is given by

$$L = \frac{E_{\text{energy}}}{\omega} . \quad (366)$$

Equivalently, the angular momentum of a wave is $\lambda/2\pi$ times its linear momentum. For light, this result has been confirmed already in the early 20th century: a light beam can put certain materials (which ones?) into rotation, as shown in Figure 159. Of course, the whole thing works even better with a laser beam. In the 1960s, a beautiful demonstration was performed with microwaves. A circularly polarized microwave beam from a maser – the microwave equivalent of a laser – can put a metal piece absorbing it into rotation. For a beam with cylindrical symmetry, depending on the sense of rotation, the angular momentum is either parallel or antiparallel to the direction of propagation. All these experiments confirm

Challenge 80

Ref. 33

Challenge 97

that light also carries angular momentum, an effect which will play an important role in the second part of our mountain ascent.

We note that not for all waves angular momentum is energy per angular frequency. This is only the case for waves made of what in quantum theory will be called spin 1 particles. For example, for gravity waves the angular momentum is *twice* this value, and they are therefore expected to be made of spin 2 particles.

In summary, light can touch and be touched. Obviously, if light can rotate, it can also *be* rotated. Could you imagine how this can be achieved?

Challenge 114

War, light, and lies

From the tiny effects of the equation (365) for light pressure one deduces that light is not an efficient tool for hitting objects. However, light is able to heat up objects, as one can feel on the skin if it is touched by a laser beam of about 100 mW or more. For the same reason even cheap laser pointers are dangerous to the eye.

Challenge 131

In the 1980s, and again in 2001, a group of people who read too many science fiction novels managed to persuade the military – who also indulge in this habit – that lasers could be used to shoot down missiles, and that a lot of tax money should be spent to develop such lasers. Using the definition of the Poynting vector and a hitting time of about 0.1 s, are you able to estimate the weight and size of the battery necessary for such a device to work? What would happen in cloudy or rainy weather?

Challenge 148

Other people tried to persuade NASA to study the possibility to propel a rocket using light instead of ejected gas. Are you able to estimate whether this is feasible?

What is colour?

Challenge 165

We saw that radio waves of certain frequencies are visible. Within that range, different frequencies correspond to different colours. (Are you able to convince a friend about this?) But the story is not finished here. Numerous colours can be produced either by a single wavelength, i.e. by *monochromatic* light, or by a *mixture* of several other, different colours. For example, standard yellow can be, if it is pure, a beam of 600 nm, or it can be a mixture of standard green of 546.1 nm and standard red of 700 nm. The eye cannot distinguish between the two cases. In everyday life, all colours are mixed, with the exception of those of yellow street lamps, of most laser beams, and of the rainbow. You can check this yourself, using an umbrella or a compact disk.

Challenge 182

In particular, white light is a mixture of a continuous range of colours with a given intensity per wavelength. To check that white light is a mixture of colours, simply hold Figure 160 so near to your eye that you cannot focus the stripes any more. The unsharp borders of the white stripes have a pink or a green shade. These colours are due to the imperfections of the lens in the human eye, its so-called *chromatic aberrations*. Aberrations have

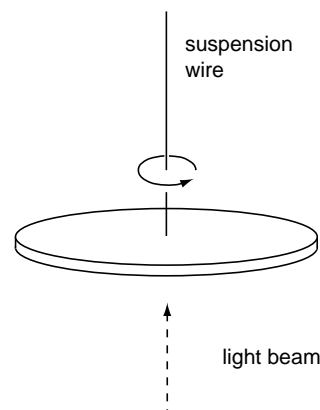

Figure 159 Light can rotate objects

the consequence that not all light frequencies follow the same path in the lens of the eye, and therefore that they hit the retina at different spots. This is the same effect that occurs in prisms or in water drops showing a rainbow. By the way, the shape of the rainbow tells something about the shape of the water droplets. Can you deduce the connection?

Challenge 199

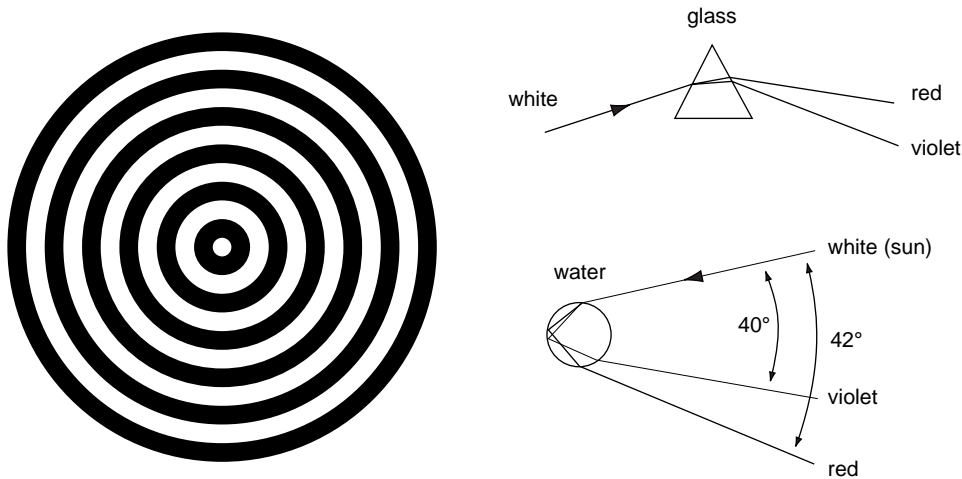

Figure 160 Proving that white light is a mixture of colours

Even pure air splits white light. This is the reason that the sky or far away mountains are blue and that the sun is red at sunset and at dawn. You can repeat this effect by looking through water at a black surface or at a lamp. Adding a few drops of milk to the water makes the lamp yellow and then red, and makes the black surface blue (like the sky seen from the earth as compared to the sky seen from the moon). More milk increases the effect. For the same reason, sunsets are especially red after volcanic eruptions.

Challenge 216

By the way, at sunset the atmosphere itself acts as a prism as well; that means that the sun is split into different images, one for each colour, which are slightly shifted against each other, a bit like a giant rainbow in which not only the rim, but the whole disk is coloured. The total shift is about 1/60th of the diameter. If the weather is favourable, and if the air is clear and quiet up to and beyond the horizon, for a few seconds it is possible to see, after the red, orange and yellow images have set, the rim of the green-blue image of the sun. That is the famous 'rayon vert' described by Jules Verne in his novel of the same title. It is often seen from islands, such as Hawaii.*

Ref. 34

To clarify the difference between colours in physics and colour in human perception and language, a famous discovery deserves to be mentioned: colours in language have a natural *order*. (Colours which point to objects, such as aubergine or sepia, or colours which are not generally applicable, such as blond, are excluded in this discussion.) Colours are ordered by all people in the following order: 1st black and white, 2nd red, 3rd green and yellow, 4th blue, 5th brown; 6th come mauve, pink, orange, grey and sometimes a twelfth term different

* About this and many other topics on colours in nature, such as e.g. the colour of shadows, the halos around the moon and the sun, and many others, see the beautiful book by Marcel Minnaert mentioned on page 59.

from language to language. The result states that if a particular language has a word for any of these colours, it also has a word for all the preceding ones. The result also implies that people use these basic colour classes even if their language does *not* have a word for each of them. These strong statements have been confirmed for over 100 languages.

Ref. 35

What is the speed of light? – Again

Physics is talking about motion. Talking is the exchange of sound; and sound is an example of a signal. A (*physical*) *signal* is the transport of information using transport of energy. There are no signals without motion of energy. This is also obvious from the fact that there is no way to store information without storing energy. To any signal one can thus ascribe a propagation speed. The highest possible signal speed is also the maximal velocity of general influences, or, using sloppy language, the maximal velocity with which effects spread causes.

If the signal is carried by matter, such as by the written text in a letter, the signal velocity is then the velocity of the material carrier, and experiments show that it is limited by the speed of light.

For a wave carrier, such as water waves, sound, light or radio waves, the situation is less evident. What is the speed of a wave? The first answer that comes to mind is the speed with which wave crests of a sine wave move. This already introduced *phase velocity* is given by the ratio between the frequency and the wavelength of a monochromatic wave, i.e. by

$$v_{ph} = \frac{\omega}{k} \quad (367)$$

For example, the phase velocity determines interference phenomena. Light in vacuum has the same phase velocity $v_{ph} = c$ for all frequencies. Are you able to imagine an experiment to test this to high precision?

Challenge 233

On the other hand, there are cases where the phase velocity is larger than c , most notably when light travels through an absorbing substance, and when at the same time the frequency is near to an absorption maximum. In these cases, experiments show that the phase velocity is *not* the signal velocity. For such situations, a better approximation to the signal speed is the *group velocity*, i.e. the velocity at which a group maximum will travel. This velocity is given by

Ref. 36

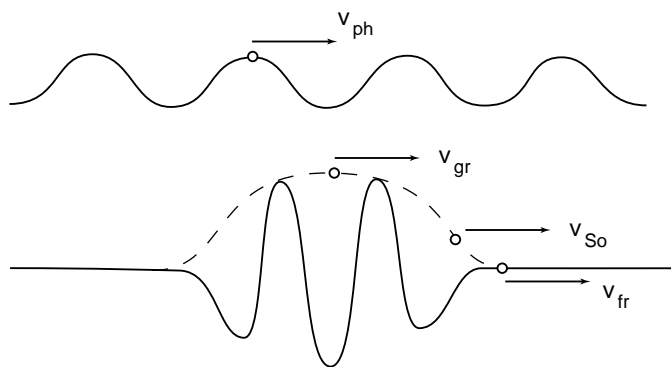

Figure 161 The definition of important velocities in wave phenomena

$$v_{gr} = \left. \frac{d\omega}{dk} \right|_{k_0} \quad (368)$$

where k_0 is the central wavelength of the wave packet. One observes that $\omega = c(k)k = 2\pi v_{\text{ph}}/\lambda$ implies the relation

$$v_{\text{gr}} = \left. \frac{d\omega}{dk} \right|_{k_0} = v_{\text{ph}} + \lambda \frac{dv_{\text{ph}}}{d\lambda} . \quad (369)$$

This means that the sign of the last term determines whether the group velocity is larger or smaller than the phase velocity. For a travelling group, as shown by the dotted line in Figure 161, this means that new maxima either appear at the end or at the front of the group. Experiments show that for light *in vacuum*, the group velocity has the same value $v_{\text{gr}} = c$ for all values of the wave vector k .

One should be warned however that still many publications propagate the myth that the group velocity *in materials* is never larger than c , the speed of light in vacuum. Actually, the group velocity in materials can be zero, or infinite, or even negative; this happens when the light pulse is very narrow, i.e. when it includes a wide range of frequencies, or again when one is near an absorption transition. In many (but not all) cases the group is found to widen substantially or even to split, making it difficult to define precisely the group maximum and thus its velocity. Many experiments have confirmed these predictions. For example, the group velocity in certain materials has been measured to be *ten times* that of light. The refractive index then is smaller than 1. * However, in all these cases the group velocity is *not* the same as the signal speed. **

Challenge 250

Ref. 37

What then is the best velocity describing signal propagation? The German physicist Arnold Sommerfeld *** almost solved the main problem in the beginning of the twentieth century. He defined the signal velocity as the velocity v_{So} of the front slope of the pulse, as shown in Figure 161. The definition cannot be summarized in a formula, but it does have the property that it describes signal propagation for practically all experiments, in particular those in which the group and phase velocity are larger than the speed of light. When studying its properties, one finds that for no material Sommerfeld's signal velocity is larger than the speed of light in vacuum.

Ref. 36

One might think that it is conceptually easier to describe signal propagation with help of the energy velocity. As mentioned before, every signal transports energy. The *energy velocity* v_{en} is defined as the ratio between the power flow density \mathbf{P} , i.e. the Poynting vector, and the energy density W , both taken in the direction of propagation. For electromagnetic fields – the only ones fast enough to be interesting for eventual superluminal signals – this ratio is

$$\mathbf{v}_{\text{en}} = \frac{\text{Re}(\mathbf{P})}{W} = \frac{2c^2 \mathbf{E} \times \mathbf{B}}{\mathbf{E}^2 + c^2 \mathbf{B}^2} . \quad (370)$$

Challenge 267

* Some people have even found $n < 0$ for certain microwaves. Can you imagine what this means?

** In quantum mechanics, Schrödinger proved that the velocity of an electron is given by the group velocity of its wavefunction. Therefore the same discussion reappeared in quantum theory, as we will find out in the second part of the mountain ascent.

*** Arnold Sommerfeld (1868, Königsberg–1951, München) was a central figure in the spread of special and general relativity, of quantum theory, and of their applications. Professor in Munich, an excellent teacher and text book writer, he worked on atomic theory, on the theory of metals, on electrodynamics, and was the first to understand the importance and the mystery around 'Sommerfeld's famous fine structure constant.'

However, like in the case of the front velocity, also in the case of the energy velocity one has to specify if one means the energy transported by the main pulse or by the front. In vacuum, neither is ever larger than the speed of light.* (In general, the energy velocity in matter has a value slightly different from Sommerfeld's signal velocity.)

Ref. 36

In recent years, the progress in light detector technology, allowing to detect even the tiniest energies, has forced people to take the fastest of all these energy velocities to describe signal velocity. Using detectors with the highest possible sensitivity one can use as signal the first point of the wave train whose amplitude is different from zero, i.e. the first tiny amount of energy arriving. This point's velocity, conceptually similar to Sommerfeld's signal velocity, is commonly called the *front velocity*, or, to distinguish it even more clearly from Sommerfeld's case, the *forerunner velocity*. It is simply given by

Challenge 284

$$v_{\text{fr}} = \lim_{\omega \rightarrow \infty} \frac{\omega}{k} . \quad (371)$$

The forerunner velocity is *never* larger than the speed of light in vacuum, even in materials. In fact it is precisely c , because for extremely high frequencies, the ratio ω/k is independent of the material, and vacuum properties take over. The forerunner velocity is the true signal velocity, or if one wants, the *true velocity of light*. Using it, all discussions on light speed become clear and unambiguous.

In the years from 2000 to 2002, the issue reappeared in another way. It started with the prediction that the index of refraction could have *negative* values. Then a 'confirmation' for microwaves was published. But in 2002 it was shown that negative refraction indices, which imply speeds larger than unity, are only possible for either phase velocity or even group velocity, but not for the energy or true signal velocity. The problems arise because in some physical systems the refraction angle for phase motion and for energy motion differ.

Ref. 40

To finish this section, here are two questions. Which of all the velocities of light is measured in experiments determining the velocity of light, e.g. when light is sent to the moon and reflected back? And now a more difficult question: why is the signal speed of light slower inside matter, as all experiments show?

Challenge 301

Challenge 318

Signals and predictions

When somebody reads a text through the phone to a neighbour, who listens to it and maybe repeats it, one speaks of communication. For any third person, the speed of communication is always smaller than the speed of light. But if the neighbour already knows the text, he can say it without waiting to hear the readers' voice. To the third observer such a situation looks like faster than light (superluminal) communication. Prediction can thus *mimic* communication, and in particular, it can mimic faster than light communication. Such a situation has been demonstrated most spectacularly in 1994 by Günter Nimtz, who seemingly transported music – all music is predictable for short time scales – through a 'faster-than-light' system. To distinguish between the two situations, one notes that in the case of prediction, no energy

Ref. 41

* Signals not only carry energy, they also carry negative entropy ('information'). The entropy of a transmitter increases during transmission. The receiver decreases in entropy (but less than the increase at the transmitter, of course).

Ref. 38

Note that the negative group velocity implies energy transport against the propagation velocity of light. This is possible only in *energy loaded* materials.

Ref. 39

transport takes place, in contrast to the case of communication. In other words, the definition of a signal as a transport of information is not as useful and clear-cut as the definition of a signal as *transport of energy*. In the mentioned experiment, no energy was transported faster than light. The same distinction between prediction on one hand and signal or energy propagation on the other hand will be used later on to clarify some famous experiments in quantum mechanics.

If the rate at which physics papers are being published continues to increase, physics journals will soon be filling library shelves faster than the speed of light. This does not violate relativity since no useful information is being transmitted.

Why can we talk to each other? – Huygens' principle

The properties of our environment often appear in the full importance only when one asks simple questions. Why can we use the radio? Why can we talk on portable phones? Why can we listen to each other? It turns out that a central part of the answer is given by the fact that we live in a space of odd dimensions.

In spaces of even dimensions, one cannot talk, because messages do not stop. This is an important result which is easily checked by throwing a stone into a lake: even after the stone has disappeared, waves are still emitted from the point at which it entered the water. On the contrary, when we stop talking, no waves are emitted any more.

– CS – text to be added – CS –

One can also say that Huygens' principle holds if the wave equation is solved by a circular wave leaving no amplitude behind it. Mathematicians translate this by saying that the delta function $\delta(c^2t^2 - r^2)$ satisfies the wave equation, i.e. that $\partial_t^2\delta = c^2\Delta\delta$. The delta function is that strange 'function' which is zero everywhere except at the origin, where it is infinitely high. A few more properties, not mentioned here, fix the precise way this happens. If one generalizes this to higher dimensions, it turns out that the fundamental solution of the wave equation is zero everywhere only if the space dimension is odd and larger or equal to three.

In summary, when we switch off the light, a room gets dark only because we live in a space of odd dimensions.

How does the world look when riding on a light beam?

This was the question the teenager Albert Einstein tried to answer.* The situation would have strange consequences.

- One would have no mirror image, like a vampire.
- Light would not be oscillating, but a static field.
- Nothing would move, like in the tale of sleeping beauty.

But also at speeds *near* the velocity of light observations would be interesting. One would

- see a lot of light coming towards one and almost no light from behind; the sky would be blue/white in front and red/black in the back;

* He took the question from a book on the sciences by Aaron Bernstein which he read at that time.

- observe that everything around happens very very slowly;
- experience the smallest dust particle as deadly bullet.

Challenge 335 Can you think of more strange consequences? It is rather reassuring that our planet moves rather slowly through its environment.

Does the aether exist?

Gamma rays, light, and radio waves are moving electromagnetic waves. All exist in empty space. What is oscillating when the light comes along? Maxwell himself called the ‘medium’ in which this happens the *aether*. The properties of the aether found in experiments are listed in Table 36.

Physical property	experimental value
permeability	$\mu_0 = 1.3 \mu\text{H/m}$
permittivity	$\epsilon_0 = 8.9 \text{ pF/m}$
wave impedance/resistance	$Z_0 = 376.7 \Omega$
conformal invariance	applies
spatial dimensionality	3
topology	\mathbb{R}^3
mass and energy content	not detectable
friction on moving bodies	not detectable
own motion	not detectable

Table 36 Experimental properties of the aether and of flat vacuum

Ref. 42 The last item of the table is the most important: despite intensive efforts, nobody has been able to detect any *motion* of the aether. In other words, even though the aether oscillates, it does not move. Together with the other data, all these results can be summarized in one

Challenge 352 sentence: there is no way to distinguish the aether from the vacuum: both are one and the same.

One sometimes hears that relativity or certain experiments show that the aether does not exist. This is incorrect. All the data only show that the aether is indistinguishable from the vacuum. Of course, if one uses the change of curvature as definition for motion of the vacuum, vacuum *can* move, as we will find out in the section on general relativity; but aether still remains indistinguishable from it.*

Ref. 43 Later in our mountain ascent we will even find out that the ability of the vacuum to allow the propagation of light and its ability to allow the propagation of particles are equivalent: both require the same properties. Therefore the aether remains *indistinguishable* from vacuum in the rest of our walk. In other words, the aether is a superfluous concept; we drop it from our walk from now on. However, we are not finished with the study of the vacuum;

Ref. 43 * In fact, the term ‘aether’ has been used as an expression for several different ideas, depending on the author. First of all it was used for the idea that vacuum is not empty, but *full*; secondly, that this fullness can be described by *mechanical models*, such as gears, little spheres, vortices, etc.; thirdly, that vacuum is *similar to matter*, being made of the same substrate. Interestingly, some of these issues will reappear in the third part of our mountain ascent.

it will keep us busy for a long time, starting with the intermezzo following this chapter. Moreover, quite a few of the aspects in Table 36 will require some amendments later on.

15. Lightning, levitation, and other fun challenges

Electromagnetism and light are almost endless topics. A few points are worth pondering.

- How does one wire a light bulb, the mains, and three switches so that the light can be switched on at any of the switches and off at any other switch? And in case of four switches? Nobody will take a physicist serious who can write Maxwell's equations but cannot solve this little problem. Challenge 369
- Can you make a mirror that does not exchange left and right? In two different ways? Challenge 386
- A concave mirror shows an inverted image, if the mirror is bend along the horizontal line. What happens if this mirror is turned around the line of sight? Challenge 403
- Electricity produced by friction and by flows of liquids is a small effect. However, in the 1990s, several oil tankers disappeared suddenly, because they had washed their oil tanks by pointing a hose spraying sea water on their walls. The spraying led to charging; with the oil fumes in the tank this led to an explosion and the tankers sank. Similar accidents also happen regularly when chemicals are filled from one tank to another.
- When a ship sinks, survivors usually end up in small boats drifting on the sea. Often they are saved by a rope hanging from a helicopter. It is essential a survivor only touches the rope *after* the rope has been in the water, as he can die of heart attack otherwise: the helicopter can be heavily charged.
- The names anode and cathode were suggested by William Whewell and popularized by Michael Faraday. Whewell formed them from the greek; they literally mean 'upward street' and 'descending street'.
- The shortest light pulse produced so far had a length of 100 as. How many wavelengths of green light would that correspond to? Challenge 420
- Why doe one see shadows of houses, shadow of trees, but never shadows of the electrical cables hanging over streets? Challenge 437
- How would you measure the speed of the tip of a lightning? What range do you expect? Challenge 454
- How would you show that electrical charge comes in smallest chunks? Challenge 471
- One of the simplest possible electric motors was discovered by Faraday in 1831. A magnet suspended into mercury starts to turn around its axis if a current flows through it. In addition, if the magnet is made to turn from outside, the device (in other geometries also called Barlow's wheel) also works as a current generator, and people even tried to generate domestic current with such a system! Can you explain how it works? Ref. 52
- Cosmic radiation consists of charged particles hitting the earth. (We will discuss it in more detail later.) Astrophysicists explain that these particles are accelerated by the magnetic fields around the galaxy. However, the expression of the Lorentz acceleration shows that magnetic fields can only change the direction of the velocity of charges, not its magnitude. How can one get acceleration nevertheless? Challenge 488
- The magnetic field of the earth, much higher than that of other planets because of the moon, with a dipole strength of $7.8 \cdot 10^{22} \text{ Am}^2$, shields us from lethal solar wind and cosmic radiation particles. We owe it our life. See page 616
Ref. 44
- The magnetic field of the earth, much higher than that of other planets because of the moon, with a dipole strength of $7.8 \cdot 10^{22} \text{ Am}^2$, shields us from lethal solar wind and cosmic radiation particles. We owe it our life. Challenge 505
Ref. 60

▪ The ionosphere around the earth has a resonant frequency of 7 Hz; for this reason any apparatus measuring low frequencies always gets a strong signal at this value.

Challenge 522

Can you give an explanation of the frequency?

▪ What would be the potential of the earth if one could take all the electrons of a drop of water away?

Challenge 539

▪ The sun would be visible to the naked eye only up to a distance of 50 light years. True?

Challenge 556

▪ At home, electricity is mostly used as alternating current. In other words, no electron actually flows through cables; as the speed of metal electrons is about 1 mm/s, electrons just move back and forward by 20 μm. Nothing is flowing in or out of the cables! Why do the electricity companies require an actual flow of money in return, instead of being satisfied with a back and forth motion of money?

Challenge 573

▪ If one calculates the Poynting vector for a charged up magnet – or simpler, a point charge near a magnet – one gets a surprise: the electromagnetic energy flows in circles around the magnet. Where does this angular momentum come from?

Challenge 590

Worse, any atom is an example of such a system – actually of two such systems. Why is this effect not taken into account in calculations in quantum theory?

Ref. 45

▪ Ohm's law, the observation that for almost all materials the current is proportional to the voltage, is due to a high school teacher. Georg Simon Ohm explored the question in great depth; at those times, such measurements were difficult to perform. * This has changed now. Recently, even the electrical resistance of single atoms has been measured: in the case of xenon it turned out to be about 10⁵ Ω. It was also found that lead atoms are ten times more conductive than gold atoms. Can you imagine why?

Ref. 46

Challenge 607

▪ The charges on two capacitors in series are not generally equal, as naive theory states. For perfect, leak-free capacitors the voltage ratio is given by the inverse capacity ratio $V_1/V_2 = C_2/C_1$, due to the equality of the electric charges stored. However, in practice this is only correct for a few up to a few dozen minutes. Why?

Ref. 47

Challenge 624

▪ Does it make sense to write Maxwell's equations in vacuum? Both electrical and magnetic fields require charges in order to be measured. But in vacuum there are no charges! In fact, only quantum theory solves this apparent contradiction. Are you able to imagine how?

Challenge 641

Ref. 48

▪ Grass is usually greener on the other side of the fence. Can you give an explanation based on observations for this statement?

Challenge 658

▪ Inside a conductor there is no electric field. Thus there is no danger if a lightning hits an aeroplane, as long the plane is made of metal. Aeroplanes are so-called *Faraday cages*. More generally speaking, a field or a charge on the metal surface of a body does not influence fields and charges inside it. Can you give an explanation?

Challenge 675

* Georg Simon Ohm (1789, Erlangen–1854, München), bavarian school teacher and physicist. His efforts were recognized only late in his life, and he eventually was promoted to professor at the University in München. Later the unit of *electrical resistance*, the proportionality factor between voltage and current, was named after him.

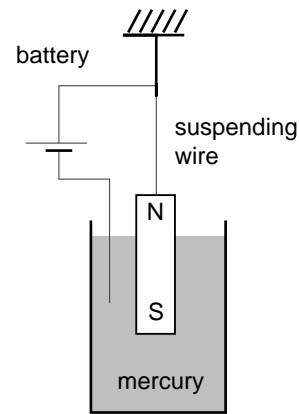

Figure 162 Unipolar motor

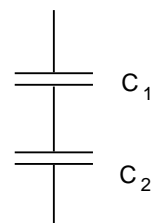

Figure 163 Capacitors in series

The explanation will allow you to answer the following question. Are there Faraday cages for gravity as well? Why?

Cars also are good approximations of Faraday cages. If your car is hit by lightning in dry weather, you should wait a few minutes before leaving it, though. Can you imagine why?

Faraday cages also work the other way round. Electric fields changing inside a Faraday cage are not felt outside. For this reason, radios, mobile phones and computers are surrounded by boxes made of metal or metal-sprayed plastics. The metal keeps the so-called *electromagnetic smog* inside buildings to a minimum.

For purely magnetic fields, the situation is more complex. It is quite difficult to shield the inside of a machine from outside magnetic fields. How would you do it? In practice one often uses layers of so-called *mu-metal*; can you guess what this material does?

- The *electric polarizability* is the property of matter responsible for the deviation of water flowing from a faucet by a charged comb. It is defined as the strength of electric dipole induced by an applied electric field. The definition simply translates the observation that many objects acquire charges when an electric field is applied. Incidentally, how precisely combs get charged when rubbed, a phenomenon called *electrification*, is still one of the mysteries of modern science.

See page 340

- A pure magnetic field cannot be transformed into a pure electric field by change of observations frame. The best that can happen is that one gets a state similar to an equal mixture of magnetic and electric fields. Can you provide an argument elucidating this relation?

Challenge 692

- Researchers are trying to detect tooth decay with help of electric currents, using the fact that healthy teeth are bad conductors, in contrast to teeth with decay. How would you make use of this effect in this case?

Ref. 49

- A team of camera men in the middle of the Sahara were using battery driven electrical equipment to make sound recordings. Whenever the microphone cable was a few tens of metres long, they also heard a 50 Hz power supply noise, even though the next power supply was thousands of kilometres away. An investigation found that the high voltage lines in Europe lose a considerable amount of power by irradiation; those 50 Hz waves are reflected by the ionosphere around the earth and thus can disturb recording in the middle of the desert. Can you estimate whether this observation implies that living directly near a high voltage line is dangerous?

Challenge 709

Challenge 726

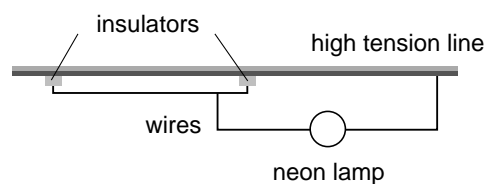

Figure 164 Small neon lamps on a high voltage cable

When solar plasma storms are seen on the sun, astronomers first of all phone the electricity company. They know that about 24 to 48 hours later, the charged particles ejected by the storms will arrive on earth, making the magnetic field on the surface fluctuate. Since power grids often have closed loops of several thousands of kilometres, additional electric currents are induced, which can make transformers in the grid overheat and then switch off. Then other transformers have to take over the additional power, which can lead to their

- On certain high voltage cables leading across the landscape, small neon lamps shine when the current flows. How is that possible?

Challenge 743

- When two laser beams cross at a small angle, one can form light pulses which seem to move faster than light. Does this contradict special relativity?

Ref. 53

- When solar plasma storms are seen on the sun, astronomers first of all phone the elec-

overheating etc. The electricity companies avoid the problems by disconnecting the various grid sections, by avoiding large loops, by reducing the supply voltage to avoid saturation of the transformers, and by disallowing load transfer from failed circuits to others.

Ref. 50

Challenge 760

▪ Can you explain to a non-physicist how a microscope works? * Heisenberg almost missed his PhD exam because he could not.

Challenge 777

▪ Is it really possible to see stars from the bottom of a deep pit or of a well during daytime, as often stated in print?

Ref. 51

▪ If one describes the electric fields as a sum of components of different frequencies, its so-called Fourier components, one finds that the amplitudes are given by

$$\hat{\mathbf{E}}(k, t) = \frac{1}{(2\pi)^3/2} \int \mathbf{E}(x, t) e^{-i\mathbf{k}\mathbf{x}} d^3x \quad (372)$$

and similarly for the magnetic field. It then turns out that a Lorentz invariant quantity N , describing the energy per circular frequency ω , can be defined:

$$N = \hat{\mathbf{E}}(k, t) = \frac{1}{8\pi} \int \frac{|\mathbf{E}(k, t)|^2 + |\mathbf{B}(k, t)|^2}{c|\mathbf{k}|} d^3k \quad (373)$$

Challenge 794

Can you guess what N is physically? (Hint: think about quantum theory.)

▪ Faraday discovered how to change magnetism into electricity, knowing that electricity could be transformed into magnetism. He also found how to transform electricity into light and into chemistry. He then tried to change gravitation into electricity. But he was not successful. Why?

Challenge 811

▪ Take an envelope, wet it and close it. After letting it dry for a day or more, open it in the dark. At the place where the two papers are being separated from each other, the envelope

Challenge 828

glows with a blue colour. Why?

▪ At high altitudes above the earth, gases are completely ionized; no atom is neutral. One speaks of ionosphere, as space is full of positive ions and free electrons. Even though both charges appear in exactly the same number, a satellite moving through the ionosphere acquires a negative charge. Why? How does the charging stop?

Challenge 845

▪ A capacitor of capacity C is charged with a voltage U . The stored electrostatic energy is $E = CU^2/2$. The capacitor is then detached from the power supply and branched onto an empty capacitor of the same capacity. After a while, the voltage obviously drops to $U/2$. However, the stored energy now is $C(U/2)^2$, which is half the original value. What

Challenge 862

happened?

Is lighting a discharge? – Electricity in the atmosphere

Looking carefully, the atmosphere is full of electrical effects. The most impressive electrical phenomenon we observe, the lightning, is now reasonably well understood. Inside a thunderstorm cloud, especially inside tall *cumulonimbus* clouds, ** charges are separated by collision between the falling large ‘graupel’ ice crystals falling due to their weight and the small ‘hail’ ice crystallites rising due to thermal upwinds. Since the collision takes part

Ref. 54

* If not, read the beautiful text by ELIZABETH M. SLATER & HENRY S. SLATER, *Light and electron microscopy*, Cambridge University Press, 1993.

** From Latin ‘cumulus,’ meaning heap, and ‘nimbus’, meaning big cloud. The various types of clouds all have Latin names.

in an electric field, charges are separated in a way similar to the mechanism in the Kelvin generator. Discharge takes place when the electric field becomes too high, taking a strange path influenced by ions created in the air by cosmic rays. It seems that cosmic rays are at least partly responsible for the zigzag shape of lightnings.* By the way, you have a 75% survival chance after being hit by lightning; rapid reanimation is essential to help somebody to recover after a hit.

See page 342

As a note, everybody knows how to measure the distance of a lightning by counting the seconds between the lightning and the thunder and multiplying by the speed of sound, ca. 330 m/s; it is less well known that one can estimate the *length* of the lightning bolt by measuring the *duration* of the thunder, and multiplying by it the same factor.

In the nineteen nineties, more electrical details about thunderstorms became known. Air-line pilots and passengers sometime see weak and coloured light emissions spreading from the top of thunderclouds. There are various types of such emissions, blue *jets* and mostly red *sprites* and *elves*, which are somehow due to electric fields between the cloud top and the ionosphere. The details are still under investigation, and the mechanisms are not yet clear.**

All these details are part of the electrical circuit around the earth. This fascinating part of geophysics would lead us too far from the aim of our mountain ascent. But every physicist should know that there is a vertical electric field of between 100 and 300 V/m on a clear day, as discovered already in 1752. (Can you guess why it is not noticeable in everyday life?) The field is directed from the ionosphere downwards to the ground; in fact the earth is permanently charged negatively, and on clear weather current flows downwards through the clear atmosphere, trying to *discharge* our planet. The current of about 1 kA is spread over the whole planet; it is possible due to the ions formed by cosmic radiation. (The resistance between the ground and the ionosphere is about 200 Ω , so that the total voltage drop is about 200 kV.) At the same time, the earth is constantly *charged* by several effects, of which the most important one turns out to be the lightning. In other words, contrary to what one may think, lightnings do not discharge the ground, they actually charge it up!*** Of course, lightnings do discharge the cloud to ground potential difference, but by doing so, they actually send negative charge down to the earth.

Challenge 879

The electric field is an important quantity. When helicopters save people on a raft in high sea, the rope must first be earthed by hanging it in the water, otherwise the people die from electrical shock when they first touch the rope, as happened a few times in the past. Can you explain why?

Challenge 913

Why are sparks and lightnings blue? This turns out to be a material property; the colour is given by the material that happens to be excited by the energy of the discharge, usually air. This excitation is due to the temperature of 30 kK inside the channel of a typical lightning stroke. For everyday sparks, the temperature is much smaller. Depending on the situation,

Ref. 55 * There is no ball lightning even though there is a Physics Report about them. Ball lightnings are one of the favourite myths of modern pseudo-science. Actually, they would exist if we lived in a giant microwave oven. To show this, just stick a toothpick into a candle, light the toothpick, and put it into (somebody else's) microwave at maximum power.

** For images, have a look at the interesting <http://sprite.gi.alaska.edu/html/sprites.htm> web site.

Challenge 896 *** The earth is thus charged to about -1 MC. Can you confirm this? To learn more about atmospheric currents, you may want to have a look at the popularizing review of US work by EDGAR BERING, ARTHUR FEW & JAMES BENBROOK, *The global electric circuit*, Physics Today **51**, pp. 24–30, October 1998, or the more technical overview by EDGAR BERING, Reviews of Geophysics (supplement) **33**, p. 845, 1995.

the colour may arise from the gas between the two electrodes, such as oxygen or nitrogen, or it may due to the material evaporated from the electrodes by the discharge. For an explanation of such colours, like for the explanation of all material related colours, we need to wait for the next part of our walk.

But not only electric fields are dangerous. Also electromagnetic fields can be. In 1997, with beautiful calm weather, a Dutch hot air balloon approached the powerful radio transmitter in Hilversum. But after a few minutes near the antenna, the gondola suddenly detached from the balloon, killing all passengers inside.

An investigation team reconstructed the facts a few weeks later. In modern gas balloons the gondola is suspended by high quality nylon ropes. To avoid damage by lightning and in order to avoid electrostatic charging problems all these nylon ropes contain thin metal wires which form a large equipotential surface around the whole balloon. Unfortunately, in front of the radio transmitter these thin metal wires absorbed the radio energy from the transmitter, became red hot, and melted the nylon wires. It was the first time that this was ever observed.

Electrical nerves

In 1789 the Italian medical doctor Luigi Galvani (1737–1798) discovered that electrical current makes muscles contract. Subsequent investigations confirmed that nerves make use of electrical signals. The details were clarified only in the 20th century. Nerve signals propagate by through the motion of ions in the cell membrane making up the nerve. The resulting signal speed is between 0.5 m/s and 120 m/s, depending on the nerve type.

How to prove you're holy

Light reflection and refraction are responsible for many effects. The originally indian symbol of holiness, now used throughout most of the world, is the *aureole*, also called *halo* or *Heiligenschein*, a ring of light surrounding the head. You can easily observe it around your own head. It is sufficient to get up early one morning and to look into the wet grass while turning your back to the sun. You will see an aureole around your shadow.

The effect is due to the morning dew on the grass, which reflects back the light mainly into the direction of the light source, as shown in the figure. The fun part is that if one does

Ref. 56

Retroreflective paint works in the same way; it contains tiny glass spheres which play the role of the dew. A large surface of retroreflective paint, a traffic sign for example, can also

Ref. 57

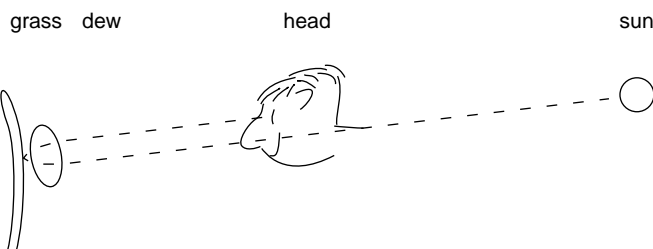

Figure 165 The path of light for dew on grass responsible for the aureole

eyes of cats at night is due to the same effect; it is visible only if one looks at the cat with a light source in one's back. By the way, does a cat-eye work like a cat's eye?

Challenge 930

Do we see what exists?

Sometimes we see *less* than there is. Close the left eye, look at the white spot in Figure 166, approach the page slowly to your eye, and pay attention to the middle lines. At a distance of about 15 to 20 cm the middle line will seem uninterrupted. Why?

Challenge 947



Figure 166 A limitation of the eye

On the other hand, sometimes we see *more* than there is, as the next two figures show.

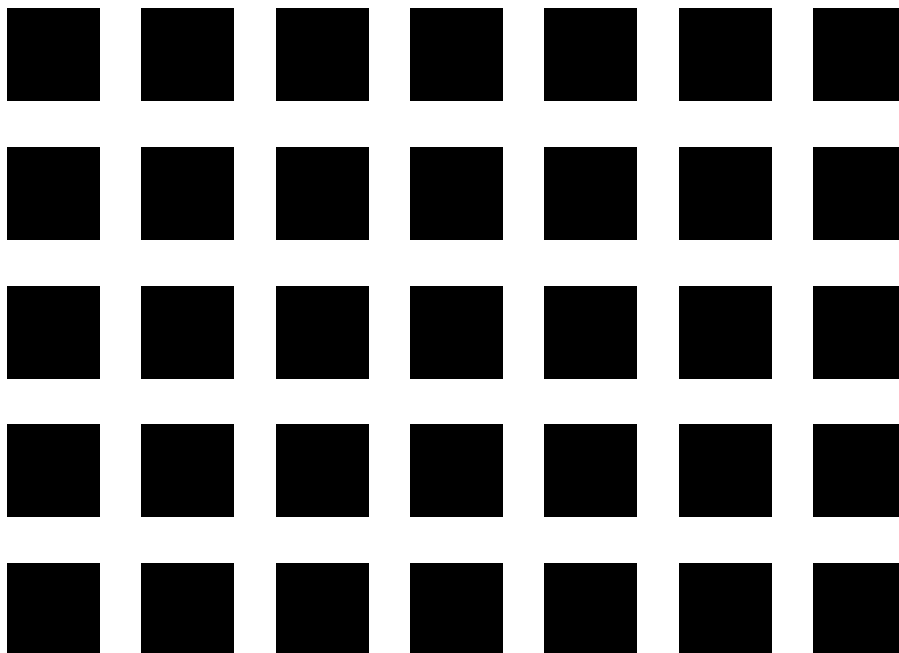

Figure 167 What is the shade of the crossings?

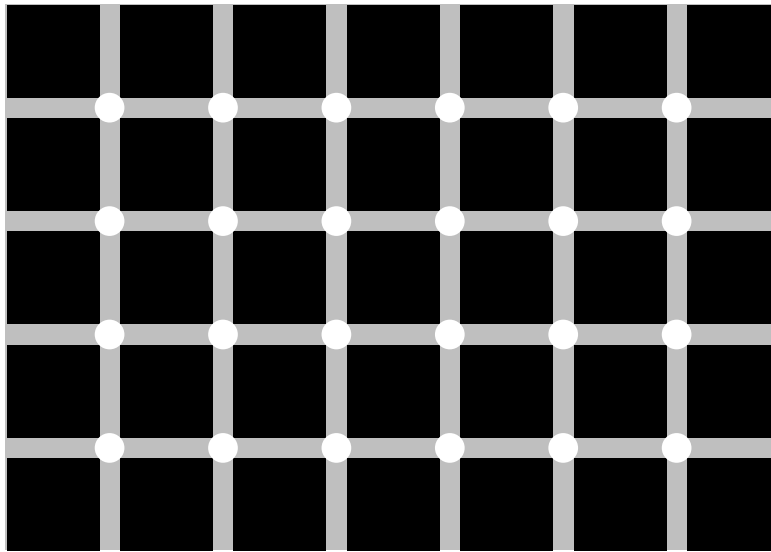

Figure 168 Do you see white, grey, or black dots?

Our eyes also sees things *differently*: the retina sees an *inverted* image of the world. There is a simple method to show this, due to Helmholtz.* You only need a needle and a piece of paper, e.g. this page of text. Use the needle to make two holes inside the two letters 'oo'. Then keep the page as near to your eye as possible, look through the two holes towards the wall, keeping the needle vertical, a few centimetres behind the paper. You will see two images of the needle. If you now cover the *left* hole with your finger, the *right* needle will disappear, and vice versa. This shows that the image inside the eye, on the retina, is inverted.

Challenge 964

Are you able to complete the proof?

We thus have to be careful when maintaining that seeing means observing. Examples such as these should make one ponder whether there could be other limitations of our senses which are less evident. And our walk will indeed uncover quite a few more.

How does one make pictures of the inside of the eye?

The most beautiful pictures so far of a *living* human retina, such as that of Figure 170, were made by the group of David Williams at the University at

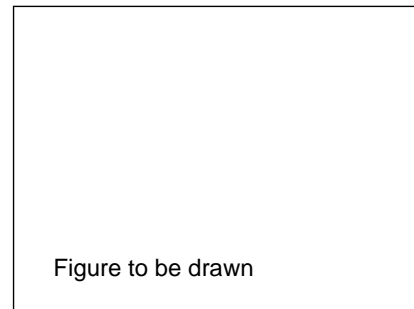
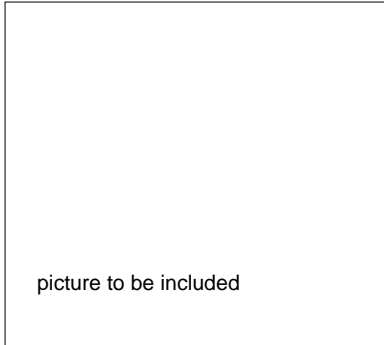

Figure 169 Eyes see inverted images

* See HERMANN VON HELMHOLTZ, *Handbuch der physiologischen Optik*, 1867. This famous classic is available in English as *Handbook of physiological optics*, Dover, 1962. The Prussian physician, physicist, and science politician born as Hermann Helmholtz (1821, Potsdam–1894) was famous for his works on optics, on acoustics, electrodynamics, thermodynamics, epistemology, and geometry. He founded several physics institutions across Germany. He was one of the first to propagate the idea of conservation of energy. His other important book, *Die Lehre von den Tonempfindungen*, published in 1863, describes the basis of acoustics, and like the handbook, is still worth to be read.

Rochester in New York. They used adaptive optics, a technique which changes the shape of the imaging lens in order to compensate for the shape variations of the lens in the human eye.

Ref. 58



The eyes see colour by averaging the intensity arriving at the red, blue and green sensitive cones. This explains the possibility, mentioned above, to get the same impression of colour, e.g. yellow, by a pure yellow laser beam, or by the mixture of red and green light.

See page 372

But if the light is focussed onto one cone only, the eye makes mistakes. If, using this adaptive optics, a red laser beam is focussed such that it hits a green cone only, a strange thing happens: even though the light is *red*, the eye sees a *green* colour!

Figure 170 A high quality photograph of a live human retina

By the way, Figure 170 is quite astounding. In the human eye, the blood vessels are located in front of the light sensitive cones. Why don't they appear in the picture? And why don't they disturb us in everyday life?

Challenge 981

Amongst mammals, only primates can see *colours*. Bulls for example, don't; they cannot distinguish red from blue. On the other hand, the best colour seers overall are the birds. They have receptors for red, blue, green, UV, and depending on the bird, for up to three more sets of colours. A number of birds also have a much better eye resolution than humans.

Does gravity make charges radiate?

We learned in the section on general relativity that gravitation has the same effects as acceleration. This means that a charge kept fixed at a certain height is equivalent to a charge accelerated by 9.8 m/s^2 , which would imply that it radiates, since all accelerated charges radiate. However, the world around us is full of charges at fixed heights, and there is no such radiation. How is this possible?

The question has been a pet topic for many years. It turns out that the answer depends on whether the observer detecting the radiation is also in free fall or not, and on the precise instant this started to be the case.

Ref. 59

– CS – to be filled in – CS –

How does one make holograms and other 3-d images?

Our sense of sight gives us the impression of depth mainly due to three effects. First of all, the two eyes see different images. Secondly, the images formed in the eyes are position dependent. Thirdly, our eye needs to focus differently for different distances.

The third effect is never used, as it is too weak. The first effect is used in stereo photography and in virtual reality systems, by sending two different images to the eyes. Alternatively, certain post cards and computer screens are covered by thin cylindrical lenses which allow to send two different images to the two eyes, thus generating the same effect.

But obviously the most spectacular effect is obtained whenever position dependent images can be created. Virtual reality systems mimic this effect by attaching a sensor to the head, and creating computer-generated images which depend on this position. Still, they pale when compared to the impression produced by holograms.

A *hologram* is a stored set of position dependent pictures of an object. It is produced by storing amplitude *and phase* of the light emitted by an object. This is possible if the object is illuminated by a *coherent* light source such as a laser. If the photographic film, after development, is then illuminated by a coherent or at least point-like source, one can see a full three-dimensional image, often floating in free space.

Is it possible to make *moving* holograms? Yes; however, the technical set-ups are extremely expensive. By the way, can you give a simple way to distinguish a moving hologram from a real body, if you ever met one? In any case, there is no way that holograms of people, similar to ghosts, can walk around and frighten real people.

Challenge 998

Research questions

The classical description of electrodynamics is coherent and complete; nevertheless there are still many subjects of research. Here are a few.

The origin of magnetic field of the earth, the other planets, the sun, and even of the galaxy is a fascinating topic. The way that the convection of fluids inside the planets generates magnetic fields, an intrinsically three dimensional problem, the influence of turbulence, of nonlinearities, of chaos etc. makes it a surprisingly complex question.

The details of the generation of the magnetic field of the earth, usually called the *geodynamo*, began to appear only in the second half of the twentieth century, when the knowledge of the earth's interior reached a sufficient level. The earth's interior is divided into the mantle – the first 2900 km from the surface – and the core. The core is made of a liquid outer core, 2300 km thick, and a solid inner core of 1215 km radius. It seems that the liquid and electrically conducting outer core acts as a dynamo which keeps the magnetic field going.

Ref. 60

The magnetic energy comes from the kinetic energy of the outer core, which rotates with respect to the earth's surface; the fluid can act as a dynamo because, apart from rotating, it also *convects* from deep inside the earth to more shallow depths, driven by the temperature gradients between the hot inner core and the cooler mantle. Huge electric currents flow in complex ways through these liquid layers, due to friction, and create the magnetic field. Understanding why this field switches orientation at irregular intervals of between a few tens of thousands and a few million years, is one of the central questions. The answers are difficult; experiments are not possible, 150 years of measurements is a short time when compared to the last transition, about 700 000 years ago, and computer simulations are extremely involved. Since the field measurements started, the dipole moment of the magnetic field has steadily diminished, and the quadrupole moment has steadily increased. Maybe we are heading towards a surprise. By the way, the study of *galactic* magnetic fields is even more complex, and still at its beginning.

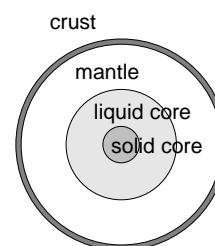

Figure 171 The structure of our planet

Another puzzle results from the equivalence of mass and energy. It is known from experiments that the size d of electrons is surely smaller than 10^{-22} m. That means that the electric field surrounding it has an energy content E given by at least

Ref. 61
Challenge 1015

$$E_{\text{energy}} = \frac{1}{2}\epsilon_0 \int E_{\text{electric field}}^2 dV = \frac{1}{2}\epsilon_0 \int_d^\infty \left(\frac{1}{4\pi\epsilon_0} \frac{q}{r^2}\right)^2 4\pi r^2 dr = \frac{q^2}{8\pi\epsilon_0} \frac{1}{d} > 1.2 \mu\text{J} \quad . \quad (374)$$

On the other hand, the *mass* of an electron, usually given as $511 \text{ keV}/c^2$, corresponds to an energy of only 82 fJ, ten million times *less* than the value just calculated. In other words, classical electrodynamics has considerable difficulty describing electrons. In fact, a consistent description of charged point particles within classical electrodynamics is still not completely achieved. This pretty topic receives only a rare – but then often passionate – interest nowadays, because the puzzle is solved in a different way in the upcoming, second part of our mountain ascent.

See page 579

Even though the golden days of materials science are over, the various electromagnetic properties of matter and their applications in devices do not seem to be completely explored yet. About once a year a new effect is discovered which merits to be included in the list of electromagnetic matter properties of Table 37. Among others, some newer semiconductor technologies will still have an impact on electronics, such as the recent introduction of low cost light detecting integrated circuits built in CMOS (complementary metal oxide silicon) technology.

See page 392

Levitation

We have seen that it is possible to move certain objects without touching them, using a magnetic or an electric field, or of course, using gravity. One naturally asks if it is also possible, without touching an object, to keep it fixed, floating in mid air? Does this type of rest exist?

It turns out that there are several methods to levitate objects. They are commonly divided into two groups: those which consume energy, and those who do not. Among the methods consuming energy one has the floating of objects on a jet of air or of water, the floating of objects through sound waves, e.g. on top of a siren, or through a laser beam coming from below, and the floating of conducting material, even of liquids, in strong radiofrequency fields. The levitation of liquids or solids by strong ultrasound waves is presently becoming popular in laboratories. These methods give *stationary* levitation. Another group of energy consuming methods sense the way a body is falling and kick it up again in the right way via a feedback loop; these methods are *non-stationary*, and usually use magnetic fields to keep the objects from falling. The magnetic train being built in Shanghai by a German consortium is levitated this way. The whole train, including the passengers, is levitated and then moved forward with electromagnets. It is thus possible, using magnets, to levitate many tens of tons of material.

Ref. 62

Ref. 63

Ref. 64

For levitation methods which do *not* consume energy – all such methods are necessarily stationary – a well-known limitation can be found studying Coulomb's 'law' of electrostatics: no static, i.e. time-independent arrangement of electric fields can levitate a *charged* object in free space or in air. The same result is valid for gravitational fields and *massive*

objects;* in other words, one cannot produce a local minimum of potential energy in the middle of a box using electric or gravitational fields. This impossibility is called *Earnshaw's theorem*. Speaking mathematically, the solutions of the Laplace equation $\Delta\phi = 0$, the so-called *harmonic functions*, have minima or maxima only at the border, and never inside the domain of definition. (You proved this yourself on page 87.) The theorem can also be proved by noting that given a potential minimum in free space, Gauss' 'law' for a sphere around that minimum requires that a source of the field be present inside, which is in contradiction with the original assumption.

One can see easily that it is also impossible to use electric fields to levitate an electrically *neutral* body in air: the potential energy U of such a body, with volume V and dielectric constant ϵ , in an environment of dielectric constant ϵ_0 , is given by

$$\frac{U}{V} = -\frac{1}{2}(\epsilon - \epsilon_0)E^2 \quad . \quad (375)$$

Challenge 1032 Since the electric field E never has a maximum in the absence of space charge, and since for all materials $\epsilon > \epsilon_0$, there cannot be a minimum of potential energy in free space for a neutral body.**

In summary, using static electric or static gravitational fields it is impossible to keep an object from falling; neither quantum mechanics, which incorporates phenomena such as antimatter, nor general relativity, including phenomena such as black holes, change this basic result.

For static *magnetic* fields, the argument is analogous to electrical fields: the potential energy U of a magnetizable body of volume V and permeability μ in a medium with permeability μ_0 containing no current is given by

Challenge 1066

$$\frac{U}{V} = -\frac{1}{2}\left(\frac{1}{\mu} - \frac{1}{\mu_0}\right)B^2 \quad (376)$$

and due to the inequality $\Delta B^2 \geq 0$, isolated maxima of a static magnetic field are not possible, only isolated minima. Therefore, it is impossible to levitate paramagnetic ($\mu > \mu_0$) or ferromagnetic ($\mu \gg \mu_0$) materials such as steel, including bar magnets, which are all attracted, and not repelled to magnetic field maxima.

Challenge 1083

There are thus two ways to get magnetic levitation: levitating a diamagnet or using a time dependent field. Diamagnetic materials ($\mu < \mu_0$) can be levitated by static magnetic fields because they are attracted to magnetic field minima; the best-known example is the levitation of superconductors, which are, at least those of type I, perfect diamagnets ($\mu = 0$). Strong forces can be generated, and this method is also being tested for the levitation of passenger trains in Japan. In some cases, superconductors can even be *suspended* in mid-air, below a magnet. Single atoms with a magnetic moment are also diamagnets; they are routinely levitated this way and have also been photographed in this state.

* To the disappointment of many science-fiction addicts, this would also be true in case that negative mass would exist, as happens for charge. See also page 63. And even though gravity is not really due to a field, the result still holds in general.

** It is possible, however, to 'levitate' gas bubbles in liquids – 'trap' them to prevent them from rising would be a better expression – because in such a case the dielectric constant of the environment is higher than that of the gas. Can you find a liquid-gas combination where bubbles fall instead of rising?

Challenge 1049

Also single neutrons, which have a magnetic dipole moment, have been kept in magnetic bottles in this way, until they decay. Recently, people have levitated pieces of wood, of plastic, strawberries, water droplets, liquid helium droplets as large as 2 cm, grasshoppers, fish, and frogs (all alive and without any harm) in this way. They are, like humans, all made of diamagnetic material. Humans themselves have not yet been levitated, but the feat is being planned and worked on.

Ref. 69

Diamagnets levitate if $\nabla B^2 > 2\mu_0\rho g/\chi$, where ρ is the mass density of the object and $\chi = 1 - \mu/\mu_0$ its magnetic susceptibility. Since χ is typically about 10^{-5} and ρ of order 1000 kg/m^3 , one needs field gradients of about $1000 \text{ T}^2/\text{m}$. In other words, levitation requires fields changes of 10 T over 10 cm, nowadays common for high field laboratory magnets.

Challenge 1100

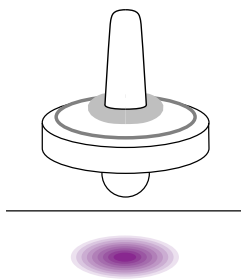

Figure 172 Floating ‘magic’ nowadays available in toy shops

Finally, *time dependent* electrical or magnetic fields, e.g. periodic fields, can lead to levitation in many different ways without any consumption of energy. This is one of the methods used in the magnetic bearings of turbomolecular vacuum pumps. Also single charged particles, such as ions and electrons, are now regularly levitated with Paul traps and Penning traps. The mechanical analogy is shown in Figure 173.

Ref. 62

Ref. 62

Figure 172 shows a toy allowing to let one personally levitate a spinning top in mid air above a ring magnet, a quite impressive demonstration of levitation for anybody looking at it. It is not hard building such a device oneself.

Ref. 70

Ref. 71

Even free electrons can be levitated, letting them float above the surface of fluid helium. In the most recent twist of the science of levitation, in 1995 Stephen Haley predicted that the suspension height of small magnetic particles above a superconducting ring should be quantized. However, the prediction has not been checked by experiment yet.

Ref. 72

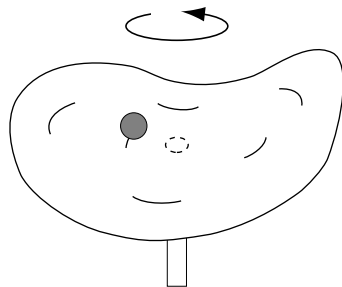

Figure 173 Trapping a metal sphere using a variable speed drill and a plastic saddle

For the sake of completeness we mention that the nuclear forces cannot be used for levitation in everyday life, as their range is limited to a few femtometres. However, we will see later that the surface matter of the sun is prevented from falling into the centre by these interactions; one could thus say that it is indeed levitated by nuclear interactions.

See page 624

Matter, levitation and electricity

Levitation used by magicians mostly falls into another class. When David Copperfield, a magician performing for the MTV generation at the end of the twentieth century, ‘flies’ during his performances, he does so by being suspended on thin fishing lines kept invisible by clever lighting arrangements. In fact, if one wants to be precise, one should count fishing lines as well as any table as levitation devices. Contrary to impression, a hanging or lying object is not

Ref. 73

really in contact with the suspension, if one looks at the critical points with a microscope. More about this in the next part of our walk.

But if this is the case, why don't we fall through a table or through the floor? We started the study of mechanics by stating as key property of matter its *solidity*, i.e. the impossibility to have more than one body at the same place at the same time. But what is the origin of solidity? Again, we will be able to answer the question only in the part on quantum mechanics, but we can collect the first clues already at this point.

See page 570

Many experiments show that matter is constituted of charged particles; indeed, matter can be moved and influenced by electromagnetic fields in many ways. Over the years, material scientists have produced a long list of such effects, all of which are based on the existence of charged constituents. * Can you find or imagine a new one? For example, can electric charge change the colour of objects?

Challenge 1117

Table 37 Selected matter properties related to electromagnetism, showing among others the role it plays in the constitution of matter; at the same time a short overview of atomic, solid state, fluid and business physics

Name of property	example	definition
thermal radiation or heat radiation or incandescence	every object	temperature dependent radiation emitted by any macroscopic amount of matter

Interactions with charges and currents

electrification	separating metals from insulators	spontaneous charging
triboelectricity	glass rubbed on cat fur	charging through rubbing
barometer light	mercury slipping along glass	gas discharge due to triboelectricity Ref. 74
insulation	air	no current flow below critical voltage drop
semiconductivity	diamond, silicon or gallium arsenide	current flows only when material is impure ('doped')
conductivity	copper, metals	current flows easily
superconductivity	niobium	current flows indefinitely
ionisation	fire flames	current flows easily
localization (weak, Anderson)	disordered solids	
resistivity, Joule effect	graphite	heating due to current flow
thermoelectric effects: Peltier effect, Seebeck effect, Thomson effect	ZnSb, PbTe, PbSe, BiSeTe, etc.	cooling due to current flow, current flow due to temperature difference, or due to temperature gradients
acoustoelectric effect	CdS	sound generation by currents, and vice versa
magnetoresistance	iron, metal multilayers	resistance changes with applied magnetic field Ref. 75
recombination	fire alarms	charge carriers combine to neutral atoms or molecules
annihilation	positron tomography	particle and antiparticle, e.g. electron and positron, disappear into photons

* Detailed descriptions of many of these effects can be found in the excellent overview edited by MANFRED VON ARDENNE, GERHARD MUSIOL & SIEGFRIED REBALL, *Effekte der Physik und ihre Anwendungen*, Harri Deutsch, 1997.

Name of property	example	definition
Penning effect	Ne, Ar	ionisation through collision with metastable atoms
Richardson effect, thermal emission	BaO ₂ , W, Mo, used in tv and electron microscopes	emission of electrons from hot metals
skin effect	Cu	high current density on exterior of wire
pinch effect	InSb, plasmas	high current density on interior of wire
Josephson effect	Nb-Oxide-Nb	tunnel current flows through insulator between two superconductors
Sasaki-Shibuya effect	n-Ge, n-Si	anisotropy of conductivity due to applied electric field
switchable magnetism	InAs:Mn	voltage switchable magnetization Ref. 76
Interactions with magnetic fields		
Hall effect	silicon; used for magnetic field measurements	voltage perpendicular to current flow in applied magnetic field
Zeeman effect	Cd	change of emission frequency with magnetic field
Paschen-Back effect	atomic gases	change of emission frequency in strong magnetic fields
ferromagnetism	Fe, Ni, Co, Gd	spontaneous magnetization; material strongly attracted by magnetic fields
paramagnetism	iron	induced magnetization parallel to applied field; attracted by magnetic fields
diamagnetism	water	induced magnetization opposite to applied field; repelled by magnetic fields
magnetostriction	CeB ₆ , CePd ₂ Al ₃	change of shape or volume by applied magnetic field
magnetoelastic effect	Fe, Ni	change of magnetization by tension or pressure
acoustomagnetic effect	metal alloys, anti-theft etiquettes	excitation of mechanical oscillations through magnetic field
spin valve effect	metal multilayers	electrical resistance depends on spin direction of electrons with respect to applied magnetic field
magneto-optical activity or Faraday effect or Faraday rotation	flint glass	polarization angle is rotated with magnetic field; different refraction index for right and left circularly polarized light, as in magneto-optic (MO) recording
magnetic circular dichroism	gases	different absorption for right and left circularly polarized light; essentially the same as the previous one
photoelectromagnetic effect	InSb	current flow due to light irradiation of semiconductor in a magnetic field
Voigt effect	vapours	birefringence induced by applied magnetic field

Name of property	example	definition
Cotton-Mouton effect	liquids	birefringence induced by applied magnetic field
Hanle effect	Hg	change of polarization of fluorescence with magnetic field
Shubnikov-de Haas effect	Bi	periodic change of resistance with applied magnetic field
thermomagnetic effects: Ettinghausen effect, Righi-Leduc effect, Nernst effect, magneto-Seebeck effect	BiSb alloys	relation of temperature, applied fields, and electric current
Ettinghausen-Nernst effect	Bi	appearance of electric field in materials with temperature gradients in magnetic fields
photonic Hall effect	CeF ₃	transverse light intensity depends on the applied magnetic field Ref. 77
magnetocaloric effect	gadolinium, GdSiGe alloys	material cools when magnetic field is switched off Ref. 78
cyclotron resonance	semiconductors, metals	selective absorption of radio waves in magnetic fields
magnetoacoustic effect	semiconductors, metals	selective absorption of sound waves in magnetic fields
magnetic resonance	most materials, used for imaging in medicine for structure determination of molecules	selective absorption of radio waves in magnetic fields
magnetorheologic effect	liquids, used in advanced car suspensions	change of viscosity with applied magnetic fields
Meissner effect	type 1 superconductors, used for levitation	expulsion of magnetic field from superconductors
Interactions with electric fields		
polarizability	all matter	polarization changes with applied electric field
ionization, field emission, Schottky effect	all matter, tv	charges are extracted at high fields
paraelectricity	BaTiO ₃	applied field leads to polarization in same direction
dielectricity	water	in opposite direction
ferroelectricity	BaTiO ₃	spontaneous polarization below critical temperature
piezoelectricity	like the quartz lighter used in the kitchen	polarization appears with tension, stress, or pressure

Name of property	example	definition
pyroelectricity	CsNO ₃ , tourmaline, crystals with polar axes; used for infrared detection	change of temperature produces charge separation
electroosmosis or electrokinetic effect	many ionic liquids	liquid moves under applied electric field Ref. 79
electrowetting	salt solutions on gold	wetting of surface depends on applied voltage
electrolytic activity	sulfuric acid	charge transport through liquid
liquid crystal effect	watch displays	molecules turn with applied electric field
electrooptical activity: Kerr effect, Pockels effect	liquids (e.g. oil), crystalline solids	material in electric field rotates light polarisation, i.e. produces birefringence
Freederichsz effect, Schadt-Helfrichs effect	nematic liquid crystals	electrically induced birefringence
Stark effect	hydrogen, mercury	colour change of emitted light in electric field
field ionisation	helium near tungsten tips in field ion microscope	ionisation of gas atoms in strong electric fields
Zener effect	Si	energy-free transfer of electrons into conduction band at high fields
field evaporation	W	evaporation under strong applied electric fields
Interactions with light		
absorption	coal, graphite	transformation of light into heat or other energy forms (which ones?) Challenge 13
blackness	coal, graphite	complete absorption in visible range
colour, metallic shine	ruby	absorption depending on light frequency
photostriction	PbLaZrTi	light induced piezoelectricity
photography	AgBr, AgI	light precipitates metallic silver
photoelectricity, photoeffect	Cs	current flows into vacuum due to light irradiation
internal photoelectric effect	Si p-n junctions, solar cells	voltage generation and current flow due to light irradiation
photon drag effect	p-Ge	current induced by photon momentum
emissivity	every body	ability to emit light
transparency	glass, quartz, diamond	low reflection, low absorption, low scattering
reflectivity	metals	light bounces on surface
polarization	pulled polymer sheets	light transmission depending on polarization angle
optical activity	sugar dissolved in water, quartz	rotation of polarization
birefringence	feldspat, cornea	refraction index depends on polarization direction, light beams are split into two beams
dichroism	feldspat	absorption depends on polarisation

Name of property	example	definition
optically induced anisotropy, Weigert effect	AgCl	optically induced birefringence and dichroism
second harmonic generation	LiNbO ₃ , KPO ₄	light partially transformed to double frequency
luminescence: general term for the opposite of incandescence	GaAs, television	cold light emission
fluorescence	CaF ₂ , X ray production, light tubes, cathode ray tubes	light emission during and after light absorption or other energy input
phosphorescence	TbCl ₃	light emission due to light, electrical or chemical energy input, continuing <i>long after</i> stimulation
electroluminescence	ZnS	emission of light due to alternating electrical field
also photo-, chemo-, tribo-, bio-, thermoluminescence		
thermoluminescence	quartz, feldspat	light emission during heating, used e.g. for archaeological dating of pottery Ref. 80
Bremsstrahlung	X ray generation	radiation emission through fast deceleration of electrons
Compton effect	momentum measurements	change of wavelength of light, esp. X rays and gamma radiation, colliding with matter
Cerenkov effect	water, polymer particle detectors	light emission in a medium due to particles, e.g. emitted by radioactive processes, moving faster than the speed of light in that medium
transition radiation	any material	light emission due to fast particles moving from one medium to a second with different refractive index
electrochromicity	wolframates	colour change with applied electric field
scattering	gases, liquids	light changes direction
Mie scattering	dust in gases	light changes direction
Raleigh scattering	sky	light changes direction, sky is blue
Raman effect or Smekal-Raman effect	molecular gases	scattered light changes frequency
laser activity, superradiation	beer, ruby, He-Ne	emission of stimulated radiation
sonoluminescence	air in water	light emission during cavitation
gravitoluminescence	fake; it does not exist; why?Challenge 30	
switchable mirror	LaH	voltage controlled change from reflection to transparency Ref. 81
radiometer effect	bi-coloured windmills	mill turn due to irradiation (see page 370)
luminous pressure	idem	opposite of the preceding one
solar sail effect	future satellites	motion due to solar wind
acoustooptic effect	LiNbO ₃	diffraction of light by sound in transparent materials
photorefractive materials	LiNbO ₃ , GaAs, InP	light irradiation changes refractive index

Name of property	example	definition
Auger effect	Auger electron spectroscopy	electron emission due to atomic reorganisation after ionisation by X rays
Bragg reflection	crystal structure determination	X ray diffraction by atomic planes
Mößbauer effect	Fe, used for spectroscopy	recoil-free resonant absorption of gamma radiation
pair creation	Pb	transformation of a photon in a charged particle-antiparticle pair
photoconductivity	Se, CdS	change of resistivity with light irradiation
optoacoustic affect, photoacoustic effect	gases, solids	creation of sound due to absorption of pulsed light
optogalvanic effect	plasmas	change of discharge current due to light irradiation
optical nonlinear effects: parametric amplification, frequency mixing, saturable absorption, n-th harmonic generation, optical Kerr effect, etc.		
phase conjugated mirror activity	gases	reflection of light with opposite phase
solidity, impenetrability	floors, columns, ropes, buckets	at most one object per place at a given time
Interactions with vacuum		
Casimir effect	metals	attraction of uncharged, conducting bodies

All matter properties in the list can be influenced by electric or magnetic fields or directly depend on them. This shows that the nature of all these material properties is electromagnetic. In other words, charges and their interactions are an essential and fundamental part of the structure of objects. The table shows so many different electromagnetic properties that the motion of charges inside each material must be complex indeed. Most effects are the topic of solid state physics, * fluid and plasma physics.

Solid state physics is by far the most important part of physics, when measured by the impact it had on society. Almost all effects have applications in technical products, and give work to many people. Can you name a product or business application for any randomly chosen effect from the table?

Challenge 47

In our mountain ascent we however, we look only at one example from the above list: thermal radiation, the emission of light by hot bodies.

Earnshaw's theorem about the impossibility of a stable equilibrium for charged particles at rest implies that the charges inside matter must be *moving*. For any charged particle in motion, Maxwell's equations for the electromagnetic field show that it radiates energy by emitting electromagnetic waves. In short, classical mechanics thus predicts that matter must radiate electromagnetic energy.

Interestingly, everybody knows from experience that this is indeed the case. Hot bodies light up depending on their temperature; the fact that light bulbs work thus proves that met-

* Probably the best and surely the most entertaining introductory English language book on the topic is the one by NEIL ASHCROFT & DAVID MERMIN, *Solid state physics*, Holt Rinehart & Winston, 1976.

als are made of charged particles. *Incandescence*, as it is called, requires charges. Actually, every body emits radiation, even at room temperature. This radiation is called *thermal radiation*; at room temperature it lies in the infrared. Its intensity is rather weak in everyday life; it is given by the general expression

Ref. 82

$$I(T) = fT^4 \frac{2\pi^5 k^4}{15c^2 h^3} \quad \text{or} \quad I(T) = f\sigma T^4 \quad \text{with} \quad \sigma = 56.7 \text{ nW/K}^4 \text{m}^2 \quad (377)$$

where f is a material, shape, and temperature dependent factor, with a value between zero and one, and called the *emissivity*. A body whose emissivity is given by the ideal case $f = 1$ is called a *black body*, because at room temperature such bodies also have an ideal absorption coefficient and thus appear black. (Can you see why?) The heat radiation they emit is called *black body radiation*.

Challenge 64

Ref. 83

Challenge 81

By the way, which object radiates more energy: a human body or an average piece of the sun of the same mass? Try to guess first.

Why can we see each other?

This use of the term ‘black’ is rather strange, since it turns out that most bodies at temperatures at which they are red hot or even hotter are good approximations of black bodies! For example, the tungsten in incandescent light bulbs, at around 2000 K, emits almost pure black body radiation; however, the glass then absorbs much of the ultraviolet and infrared components. Black bodies are also used to define the colour *white*. What we commonly call pure white is the colour emitted by a black body of 6500 K, namely the sun. This definition is used throughout the world, e.g. by the Commission Internationale d’Eclairage. Hotter black bodies are bluish, colder ones are yellow, orange or red.* The stars in the sky are classified in this way, as summarized on page 125.

Ref. 84

Let us have a quick summary of black body radiation. Black body radiation has two important properties; first, the emitted power increases with the fourth power of the temperature. With this power relation alone you can check the just mentioned temperature of the sun simply by comparing the size of the sun with the width of your thumb when the arm is stretched away from the face. Are you able to do this? (Hint: use the excellent approximation that the earth’s temperature of about 300 K is due to the sun’s irradiation.)**

Challenge 98

The precise expression for the emitted energy density u per frequency ν can be deduced from the radiation law for black bodies discovered by Max Planck in 1899:

$$u(\nu, T) = \frac{8\pi h}{c^3} \frac{\nu^3}{e^{h\nu/kT} - 1} \quad (378)$$

He made this important discovery, which we will discuss in more detail in the second part of our mountain ascent, simply by comparing this curve with experiment.*** The new constant h , *Planck’s quantum of action* or *Planck’s constant*, turns out to have the value $6.6 \cdot 10^{-34}$ Js, and is central to all quantum theory, as we will see. The other constant Planck introduced,

See page 481

Ref. 85

* Most bodies are not black, because colour is not only determined by emission, but also by absorption of light.
 ** The actual average temperature of the earth is 14.0 °C.
 *** Max Planck (1858–1947), professor of physics in Berlin, was a central figure in thermostatics. He discovered and named *Boltzmann’s constant* k and the *quantum of action* h , often called Planck’s constant. His

the Boltzmann constant k , appears as a prefactor of temperature all over thermodynamics, as it acts as a conversion unit from temperature to energy.

The radiation law gives for the total emitted energy density the expression

Challenge 115

$$u(T) = T^4 \frac{8\pi^5 k^4}{15c^3 h^3} \quad (379)$$

from which equation (377) is deduced using $I = uc/4$. (Why?)

Challenge 132

The second property of black body radiation is the value of the peak wavelength, i.e. the wavelength emitted with the highest intensity. This wavelength determines their colour; it is deduced from equation (378) to be

Challenge 149

$$\lambda_{\max} = \frac{hc}{4.956kT} = 2.9 \text{ mm K}/T \quad \text{but} \quad \hbar\nu_{\max} = 2.82kT = 3.9 \cdot 10^{-23} \text{ J/K}T \quad . \quad (380)$$

Either of these expressions is called *Wien's colour displacement* after its discoverer.* For 37 °C, human body temperature, it gives a peak wavelength of 9.3 μm , which is thus the colour of the bulk of the radiation emitted by every human being. (Note that the peak wavelength does not correspond to the peak frequency. Why?) On the other hand, following the telecommunication laws of many countries, any radiation emitter needs a licence to operate; as a consequence in Germany only dead people are legal, and only if their bodies are at absolute zero temperature.

Challenge 166

Note that a black body (also a star) can be blue, white, yellow, orange or red. It is never green. Can you explain why?

Challenge 183

Above, we predicted that any material made of charges emits radiation. Are you able to find a simple argument showing whether heat radiation is or is not this classically predicted radiation?

Challenge 200

But let us come back to the question in the section title. The existence of thermal radiation implies that any hot body will cool, even if it is left in the most insulating medium there is, namely in vacuum. More precisely, if the vacuum is surrounded by a wall, a body in the vacuum will gradually approach the same temperature as the wall.

Interestingly, when the temperature of the wall and of the body inside have become the same, something strange happens. The effect is difficult to check at home, but impressive photographs exist in the literature.

Ref. 86

An arrangement in which the walls and the objects inside are at the same temperature is called an *oven*. It turns out that one *cannot see* objects in an oven using the light coming from thermal radiation. For example, if an oven and all its contents are red hot, taking a picture of the inside of the oven (without a flash!) does not reveal anything; no contrast nor brightness changes exist which allow to distinguish the objects from the walls or their surroundings. Can you explain the finding?

Challenge 217

introduction of the quantum hypothesis was the birth date of quantum theory. He also made the works of Einstein known in the physical community, and later organized a job for him in Berlin. He received the Nobel prize for physics in 1918. He was an important figure in the German scientific establishment; he also was one of the very few who had the courage to tell Hitler *face to face* that it was a bad idea to fire Jewish professors. Famously modest, with many tragedies in his personal life, he was esteemed by everybody who knew him.

* Wilhelm Wien (1864, Gaffken–1824, München), east Prussian physicist, received the Nobel prize for physics in 1911 for the discovery of this relation.

In short, we are able to see each other only because the light sources we use are at a *different* temperature than ourselves. We can see each other only because we do *not* live in thermal equilibrium with our environment.

Could electrodynamics be different?

Any interaction like Coulomb's rule (327) which acts, for one given observer, between two particles independently of 3-velocity, must depend on 3-velocity for other inertial observers.* It turns out that such an interaction cannot be independent of the 4-velocity either. Such an interaction, even though it would indeed be 3-velocity dependent, would change the rest mass, since the 4-acceleration would not be 4-orthogonal to the 4-velocity.

The next simplest case is the one in which the acceleration is proportional to the 4-velocity. Together with the request that the interaction leaves the rest mass constant, one then recovers electrodynamics.

In fact, also the requirements of gauge symmetry and of relativity symmetry make it impossible to modify electrodynamics. In short, it does not seem possible to have a behaviour different from $1/r^2$ for a classical interaction.

A small non-vanishing mass for the photon would change electrodynamics somewhat. Experiments pose tight limits on the mass value, but the inclusion of a tiny mass poses no special problems, and the corresponding Lagrangian has already been studied in the literature, just in case.

A summary of classical electrodynamics and of its limits

In general, classical electrodynamics can be summarized in a few main ideas.

- The electromagnetic field is a physical observable, as shown e.g. by compass needles;
- its sources are the (moving) charges, described by Maxwell's evolution equations, as shown e.g. by the properties of amber, lodestone, batteries, and remote controls;
- the electromagnetic field changes the motion of electrically charged objects via the Lorentz expression, as e.g. shown by electric motors;
- it behaves like a continuous quantity, a distribution of little arrows, and propagates as a wave, as shown e.g. by radios;
- it can exist and move also in empty space, as shown e.g. by the stars.

However, there is quite some fun ahead; even though this description is correct in everyday life, during the rest of our mountain ascent we will find that *each* of these ideas is in fact wrong. A simple example shows the trouble ahead.

At a temperature of zero Kelvin, when matter does not radiate thermally, one has the paradoxical situation that the charges inside matter cannot be moving, since no emitted

* This can be deduced from the special relativity in various ways, e.g. from the reasoning of page 352, or the formula in the footnote of page 200.

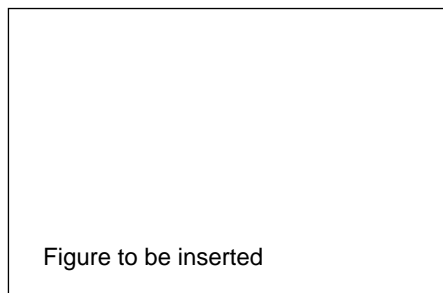
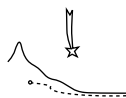

Figure 174 Hot bodies in a hot oven

radiation is observed, but they cannot be at rest either, due to Earnshaw's theorem. In short, the fact that matter actually exists shows that classical electrodynamics is wrong.

In fact, Table 37, giving an overview of material properties, makes the same point even more strongly; classical electrodynamics can describe many of the effects listed, *but it cannot explain the origin of any of them*. Even though few of the effects will be studied in our walk – they are not essential for our adventure – the general concepts necessary for their description will be the topic of the second part of this mountain ascent, that on quantum theory.

See page 392



References

- 1 JULIAN SCHWINGER, L.L. DERAAD, K.A. MILTON & W.Y. TSAI, *Classical Electrodynamics*, Perseus, Cambridge, 1998. An excellent text on the topic by one of its greatest masters.
See also the beautiful problem book by ANDRÉ BUTOLI & JEAN-MARC LÉVY-LEBLOND, *La physique en questions - électricité et magnétisme*, Vuibert, Paris, 1999. Cited on page 355.
- 2 A.S. GOLDHABER & W.P. TROWER, *Resource letter MM-1: magnetic monopoles*, American Journal of Physics **58**, pp. 429–439, 1990. Cited on page 341, 341, 341, 341.
- 3 R. EDWARDS, *Filling station fires spark cars' recall*, New Scientist, pp. 4–5, 4 March 1995. Cited on page 342.
- 4 S. DESMET, F. ORBAN & F. GRANDJEAN, *On the Kelvin electrostatic generator*, European Journal of Physics **10**, pp. 118–122, 1989. One can find construction plans for it also in various places on the internet. Cited on page 342.
- 5 See the old but beautiful papers by RICHARD C. TOLMAN & T. DALE STEWART, *The electromotive force produced by the acceleration of metals*, Physical Review **8**, pp. 97–116, 1916, RICHARD C. TOLMAN & T. DALE STEWART, *The mass of the electric carrier in copper, silver and aluminium*, Physical Review **9**, pp. 164–167, 1917, and the later but much more precise experiment by C.F. KETTERING & G.G. SCOTT, *Inertia of the carrier of electricity in copper and aluminum*, Physical Review **66**, pp. 257–267, 1944. (Obviously the American language dropped the ‘i’ from aluminium during that period.) The first of these papers is also a review of the preceding attempts, and explains the experiment in detail. The last paper shows what had to be taken into consideration to achieve sufficient precision. Cited on page 347.
- 6 This effect has first been measured by S.J. BARNETT, *Philosophical Magazine* **12**, p. 349, 1931. Cited on page 347.
- 7 See for example C. SCHILLER, A.A. KOOMANS, T.L. VAN ROOY, C. SCHÖNENBERGER & H.B. ELSWIJK, *Decapitation of tungsten field emitter tips during sputter sharpening*, Surface Science Letters **339**, pp. L925–L930, 1996. Cited on page 348.
- 8 L.I. SCHIFF & M.V. BARNHILL, *Gravitational-induced electric field near a metal*, Physical Review **151**, p. 1067, 1966. F.C. WITTEBORN & W.M. FAIRBANK, *Experimental comparison of the gravitational force on freely falling electrons and metallic electrons*, Physical Review Letters **19**, pp. 1049–1052, 1967. Cited on page 348.

- 9 See J.D. JACKSON, *Classical electrodynamics*, 3rd edition, Wiley, 1998, or also R.F. HARRINGTON, *Time harmonic electromagnetic fields*, McGraw-Hill, New York, 1961. Cited on page 352, 355.
- 10 The <http://suhep.phy.syr.edu/courses/modules/MM/Biology/biology2.html> web site gives an introduction into brain physiology. Cited on page 352.
- 11 N. SALINGAROS, *Invariants of the electromagnetic field and electromagnetic waves*, American Journal of Physics **53**, pp. 361–363, 1985. Cited on page 352.
- 12 A.C. DE LA TORRE, $V \leq c$ in 1820?, European Journal of Physics **20**, pp. L23–L24, March 1999. Cited on page 352.
- 13 MARK D. SEMON & JOHN R. TAYLOR, *Thoughts on the magnetic vector potential*, American Journal of Physics **64**, pp. 1361–1369, 1996. Cited on page 355, 356.
- 14 T.T. WU & C.N. YANG, 1975, *Concept of nonintegrable phase factors and global formulation of gauge fields*, Physical Review D **12**, pp. 3845–3857, Cited on page 357.
- 15 OLEG D. JEFIMENKO, *A relativistic paradox seemingly violating conservation of momentum law in electromagnetic systems*, European Journal of Physics **20**, pp. 39–44, 1999. Of course, the missing momentum goes into the electromagnetic field. Given that the electromagnetic momentum is given by the vector potential, are you able to check whether everything comes out right? Cited on page 358.
- 16 H. VAN DAM & E.P. WIGNER, ...Cited on page 358.
- 17 J. TRAVIS, *Twirl those organs into place – getting to the heart of how a heart knows left from right*, Science News **156**, 21 August, 1999. Cited on page 360.
- 18 See for example the discussion by M.C. CORBALLIS & I.L. BEALE, *On telling left from right*, Scientific American **224**, pp. 96–104, March 1971. Cited on page 361.
- 19 See the text by RAYMOND L. LEE & ALISTAIR B. FRASER, *The rainbow bridge: rainbows in art, myth, and science*, Pennsylvania State University Press, 2000. A chapter can be found at the <http://www.nadn.navy.mil/Oceanography/RainbowBridge/Chapter.8.html> web site. Cited on page 363.
- 20 The beautiful slit experiment was published by E.A. MONTIE, E.C. COSMAN, G.W. ‘T HOOFT, M.B. VAN DER MARK & C.W.J. BEENAKKER, *Observation of the optical analogue of quantized conductance of a point contact*, Nature **350**, pp. 594–595, 18 April 1991, and in the longer version E.A. MONTIE, E.C. COSMAN, G.W. ‘T HOOFT, M.B. VAN DER MARK & C.W.J. BEENAKKER, *Observation of the optical analogue of the quantized conductance of a point contact*, Physica B **175**, pp. 149–152, 1991. The result was also publicized in numerous other scientific magazines. Cited on page 364, 607.
- 21 A recent measurement of the frequency of light is presented in TH. UDEM, A. HUBER, B. GROSS, J. REICHERT, M. PREVEDELLI, M. WEITZ & T.W. HAUSCH, *Phase-coherent measurement of the hydrogen 1S-2S transition frequency with an optical frequency interval divider chain*, Physical Review Letters **79**, pp. 2646–2649, 6 October 1997. Another is C. SCHWOB & al., *Optical frequency measurement of the 2S-12D transitions in hydrogen and deuterium: Rydberg constant and Lamb shift determinations*, Physical Review Letters **82**, pp. 4960–4963, 21 June 1999. Cited on page 364.
- 22 See for example GÁBOR HORVÁTH, JÓZSEF GÁL & RÜDIGER WEHNER, *Why are water-seeking insects not attracted by mirages? The polarization pattern of mirages*, Naturwissenschaften **83**, pp. 300–303, 1997. Cited on page 365.
- 23 On the birefringence of the eye, see L. BOUR, *Een eigenaardige speling der natuur*, nederlandse tijdschrift voor natuurkunde **67**, pp. 362–364, december 2001. In particular, a photograph of the eye using linear polarized illumination and taken through an analyzer shows a black cross inside the pupil. Cited on page 365.

Challenge 234

- 24** The standard reference on the propagation of light is MAX BORN & EMIL WOLF, *Principles of Optics – Electromagnetic theory of propagation, interference and diffraction of light*, Pergamon Press, 6th edition, 1998. Cited on page [368](#).
- 25** An introduction into the topic of the 22° halo, the 46° halo, sun dogs, and the many other arcs and bows which can be seen around the sun, see the beautifully illustrated paper by R. GREENLER, *Lichterscheinungen, Eiskristalle und Himmelsarchäologie*, Physikalische Blätter **54**, pp. 133–139, 1998, or his book *Rainbows, halos, and glories*, Cambridge University Press 1980. Cited on page [369](#).
- 26** JAMES E. FALLER & E. JOSEPH WAMPLER, *The lunar laser reflector*, Scientific American pp. 38–49, March 1970. Cited on page [369](#).
- 27** Neil Armstrong of Apollo 11, Jim Lovell of Apollo 8 and Apollo 13, and Jim Irwin of Apollo 15 extensively searched for it and then made negative statements, as told in Science News p. 423, 24 & 31 december 1994. From the space shuttle however, which circles only a few hundred kilometers above the earth, the wall *can* be seen when the sun is low enough such that the wall appears wider through its own shadow, as explained in Science News **149**, p. 301, 1996. Cited on page [369](#).
- 28** M. SHIH, M. SEGEV & G. SALAMO, Physical Review Letters **78**, pp. 2551–2554, 1997. See also the more readable paper by MORDECHAI SEGEV & GEORGE STEGEMAN, *Self-trapping of optical beams: spatial solitons*, Physics Today **51**, pp. 42–48, August 1998. Cited on page [370](#).
- 29** The value is 4 μPa for black surfaces, and the double for mirrors. Cited on page [370](#).
- 30** The first correct explanation of the light mill was given by OSBORNE REYNOLDS, *On certain dimensional properties of matter in the gaseous state*, Royal Society Philosophical Transactions Part 2, 1879. The best discussion is the one given on the web by PHIL GIBBS, in the frequently asked question (FAQ) list of the usenet news group sci.physics; it is available at the <http://www.desy.de/user/projects/Physics/light-mill.html> web site. Cited on page [371](#).
- 31** The first experimental proof of the pressure of light was given by PETER LEBEDEV, *Untersuchungen über die Druckkräfte des Lichtes*, Annalen der Physik **6**, pp. 307–458, 1901. He is also the first one who understood that this effect is the basis for the change of direction of the tails of comets when they circle around the sun. Cited on page [371](#).
- 32** A short overview is given by MILES PADGETT & LES ALLEN, *Optical tweezers and spanners*, Physics World pp. 35–38, September 1997. The original papers by Ashkin's group are A. ASHKIN, J.M. DZIEDZIC, J.E. BJORKHOLM & S. CHU, *Observation of a gradient force optical trap for dielectric particles*, Optics Letters **11**, p. 288, 1986, and A. ASHKIN, J.M. DZIEDZIC & T. YAMANE, *Optical trapping and manipulation of single cells using infrared laser beams*, Nature **330**, p. 769, 1987. A pedagogical explanation on optical spanners, together with a way to build one, can be found in D.N. MOOTHOO, J. ARLT, R.S. CONROY, F. AKERBOOM, A. VOIT & K. DHOLAKIA, *Beth's experiment using optical tweezers*, American Journal of Physics **69**, pp. 271–276, 2001. Cited on page [371](#), [371](#).
- 33** R. BETH, Physical Review **50**, p. 115, 1936. For modern measurements, see N.B. SIMPSON, K. DHOLAKIA, L. ALLEN & M.J. PADGETT, Optics Letters **22**, p. 52, 1997, and M.E.J. FRIEZE, T.A. NIEMINEN, N.R. HECKENBERG & H. RUBINSZTEIN-DUNLOP, Optics Letters **23**, p. 1, 1998. Cited on page [371](#).
- 34** There are also other ways to see the green ray, for longer times, namely when a fata morgana appears at sunset. An explanation with colour photograph is contained in M. VOLLMER, *Gespiegelt in besonderen Düften ...– Oasen, Seeungeheuer und weitere Spielereien der Fata Morgana*, Physikalische Blätter **54**, pp. 903–909, 1998. Cited on page [373](#).

- 35** This famous discovery is by BRENT BERLIN & PAUL KAY, *Basic color terms: their universality and evolution*, 1969. Their ongoing *world colour survey* is eagerly awaited. Of course there also are ongoing studies to find possible exceptions; the basic structure is solid, as shown in the conference proceedings C.L. HARDIN & LUISA MAFFI, *Color categories in thought and language*, Cambridge University Press, 1997. Cited on page [374](#).
- 36** For a thorough discussion of the various velocities connected to wave trains, see the classic text by LOUIS BRILLOUIN, *Wave propagation and group velocity*, Academic Press, New York, 1960. It expands in detail the theme discussed by ARNOLD SOMMERFELD, *Über die Fortpflanzung des Lichtes in dispergierenden Medien*, Annalen der Physik, 4th series, **44**, pp. 177–202, 1914. See also ARNOLD SOMMERFELD, *Optik*, Dietrichssche Verlagsbuchhandlung, Wiesbaden 1950, section 22. An English translation ARNOLD SOMMERFELD, *Lectures on theoretical physics: optics*, 1954, is also available. Cited on page [374](#), [375](#), [376](#).
- 37** Such an experiment was carried out by S. CHU & S. WONG, *Linear pulse propagation in an absorbing medium*, Physical Review Letters **48**, pp. 738–741, 1982. See also S. CHU & D. STYER, *Answer to question #52. Group velocity and energy propagation*, American Journal of Physics **66**, pp. 659–661, 1998. Another example was described in 1993 by the group of Raymond Chiao for the case of certain nonlinear materials in RAYMOND CHIAO, PAUL G. KWAIT & AEPHRAIM M. STEINBERG, *Faster than light?*, Scientific American **269**, p. 52, August 1993, and R.Y. CHIAO, A.E. KOZHEKIN & G. KURIZKI, *Tachyonlike excitations in inverted two-level media*, Physical Review Letters **77**, pp. 1254–1257, 1996. On still another experimental setup using anomalous dispersion in cesium gas, see L.J. WANG, A. KUZMICH & A. DOGARIN, *Gain-assisted superluminal light propagation*, Nature **406**, pp. 277–279, 20 July 2000. Cited on page [375](#).
- 38** Y.P. TERLETSKII, *Paradoxes in the theory of relativity*, Plenum Press, New York, 1968, Cited on page [376](#).
- 39** See the excellent explanation by KIRK T. MCDONALD, *Negative group velocity*, American Journal of Physics **69**, pp. 607–614, 2001. Cited on page [376](#).
- 40** The explanation with different refraction directions was published by P. VALANJA & al., Physical Review Letters **88**, p. 187401, 2002. Two examples of materials with negative diffraction indices were presented by Sheldon Schultz; even more strangely, the theoretician John Pendry had predicted that such materials would allow to make perfect lenses, without any limit on resolution, and even allowing to use evanescent waves for imaging. Today one can say that these supposed consequences show why negative refraction indices are impossible. Cited on page [376](#).
- 41** G. NIMTZ, A. ENDERS & H. SPIEKER, Journal de Physique I (Paris) **4**, p. 565, 1994. Unfortunately, Nimitz himself seems to believe that he transported energy or signals faster than light; he is aided by the often badly prepared critics of his quite sophisticated experiments. See A. ENDERS & G. NIMTZ, Physikalische Blätter **49**, p. 1119, Dezember 1993, and the weak replies in Physikalische Blätter **50**, p. 313, April 1994. See also A.M. STEINBERG, Journal de Physique I (Paris) **4**, p. 1813, 1994, A. STEINBERG & al., Physical Review Letters **71**, pp. 708–711, 1993, and A. RANFAGNI & al., Physical Review E **48**, p. 1453, 1993. Cited on page [376](#).
- 42** A summary of all evidence about the motion of the aether is given by R.S. SHANKLAND & al., *New analysis of the interferometer observations of Dayton C. Miller*, Review of Modern Physics **27**, p. 167, 1955. An older text is H. WITTE, Annalen der Physik **26**, p. 235, 1908. Cited on page [378](#).
- 43** The history of the concept of vacuum can be found in the book by E. GRANT, *Much ado about nothing*, Cambridge University Press, 1981, and in the extensive text by EDMUND T. WHITTAKER, *A history of the theories of aether and electricity*, Volume 1: *The classical the-*

ories, Volume 2: *The modern theories*, Tomash Publishers, American Institute of Physics 1951, 1987. Cited on page 378, 378.

The various *aether models* – gears, tubes, vortices – proposed in the 19th century were dropped for various reasons. Since many models used to explain electric and magnetic fields as motion of some entities, it was concluded that the speed of light would depend on electric or magnetic fields. One type of field was usually described by linear motion of the entities, the other by rotatory or twisting motion; both assignments are possible. As a consequence, aether must be a somewhat strange fluid which flows perfectly, but which resists rotation of volume elements, as McCulloch deduced in 1839. However, experiments show that the speed of light in vacuum does not depend on electromagnetic field intensity. Vortices were dropped because real world vortices were found out to be unstable. All models received their final blow when they failed to meet the requirements of special relativity.

- 44 A.D. ERLYKIN & A.W. WOLFENDALE, *The origin of cosmic rays*, European Journal of Physics **20**, pp. 409–418, 1999, Cited on page 379.
- 45 D. SINGLETON, *Electromagnetic angular momentum and quantum mechanics*, American Journal of Physics **66**, pp. 697–701, 1998, Cited on page 380.
- 46 A. YAZDANI, D.M. EIGLER & N.D. LANG, *Off-resonance conduction through atomic wires*, Science **272**, pp. 1921–1924, 28 June 1996. For aluminium, gold, lead, niobium, as well as the influence of chemical properties, see ELKE SCHEER, *The signature of chemical valence in the electric conduction through a single-atom contact*, Nature **394**, pp. 154–157, 9 July 1998. Cited on page 380.
- 47 See L. KOWALSKI, *A myth about capacitors in series*, The Physics Teacher **26**, pp. 286–287, 1988, and A.P. FRENCH, *Are the textbook writers wrong about capacitors?*, The Physics Teacher **31**, pp. 156–159, 1993. Cited on page 380.
- 48 This problem was suggested by Vladimir Surdin. Cited on page 380.
- 49 PHILIP COHEN, *Open wide, this won't hurt a bit*, New Scientist p. 5, 3 February 1996. Cited on page 381.
- 50 The Prussian explorer Alexander von Humboldt extensively checked this myth in the 19th century. He visited many mine pits, and asked countless mine workers in Mexico, Peru, and Siberia about their experiences. He also asked numerous chimney-sweeps. Neither him nor anybody else had ever seen the stars during the day. Cited on page 382.
- 51 J.E. AVRON, E. BERG, D. GOLDSMITH & A. GORDON, *Is the number of photons a classical invariant?*, European Journal of Physics **20**, pp. 153–159, 1999. Cited on page 382.
- 52 H. MONTGOMERY, *Unipolar induction: a neglected topic in the teaching of electromagnetism*, European Journal of Physics **20**, pp. 271–280, 1999. Cited on page 379.
- 53 D. MUGNAI, A. RANFAGNI & R. RUGGIERI, Physical Review Letters **84**, p. 4830, 2000. Cited on page 381.
- 54 J. LATHAM, *The electrification of thunderstorms*, Quarterly Journal of the Royal Meteorological Society **107**, pp. 277–289, 1981. For a more recent and wider review, see EARLE R. WILLIAMS, *The tripole structure of thunderstorms*, Journal of Geophysical Research **94**, pp. 13 151–13 167, 1989. See also the book by the NATIONAL RESEARCH COUNCIL STAFF, *The earth's electrical environment*, Studies in Geophysics, National Academy Press, 1986. Cited on page 382.
- 55 B.M. SMIRNOV, *Physics of ball lightning*, Physics Reports **224**, pp. 151–236, 1993. See also D. FINKELSTEIN & J. RUBINSTEIN, *Ball lightning*, Physical Review **135**, pp. 390–396, 1964. For more folklore on the topic, just search the world wide web. Cited on page 383.

- 56 This happened to Giovanni Bellini (ca. 1430–1516) the great venetian renaissance painter, who even put this experience into writing, thus producing one of the greatest ‘gaffes’ ever. Cited on page 384.
- 57 S.R. WILK, *How retroreflectors really work*, Optics & Photonics News, pp. 6–7, December 1993. Cited on page 384.
- 58 DAVID R. WILLIAMS, *Supernormal Vision*, Science News **152**, pp. 312–313, 15 November 1997. See also http://www.cvs.rochester.edu/people/d_williams/d_williams.html as well as the photographs of the interior of living human eyes shown on http://www.cvs.rochester.edu/people/~aroorda/ao_research.html Cited on page 387.
- 59 For a recent summary, see S. PARROTT, arxiv.org:gr.qc/9711027. See also T.A. ABBOTT & D.J. GRIFFITHS, *Acceleration without radiation*, American Journal of Physics **53**, pp. 1203–1211, 1985. See also A. KOVETZ & G.E. TAUBER, American Journal of Physics **37**, p. 382, 1969. Cited on page 387.
- 60 On the geodynamo status, see the article by P.H. ROBERTS & G.A. GLATZMAIER, *Geodynamo theory and simulations*, Reviews of Modern Physics **72**, pp. 1081–1123, 2000. An older article is R. JEANLOZ & B. ROMANOWICZ, *Geophysical dynamics at the center of the earth*, Physics Today pp. 22–27, August 1997. Cited on page 379, 388.
- 61 This is deduced from the $g - 2$ measurements, as explained in his Nobel-prize talk by HANS DEHMELT, *Experiments with an isolated subatomic particle at rest*, Reviews of Modern Physics **62**, pp. 525–530, 1990, and in HANS DEHMELT, *Is the electron a composite particle?*, Hyperfine Interactions **81**, pp. 1–3, 1993. Cited on page 389.
- 62 An excellent review is E.H. BRANDT, *Levitation in Physics*, Science **243**, pp. 349–355, 1989. Cited on page 389, 391, 391.
- 63 See the article by ... in Physik in unserer Zeit February 2001. Cited on page 389.
- 64 F.C. MOON & P.Z. CHANG, *Superconducting Levitation – Applications to bearings and magnetic transportation*, Wiley & Sons, 1994. Cited on page 389, 390.
- 65 W.T. SCOTT, *Who was Earnshaw?*, ... pp. 418–419, 1959. Cited on page 390.
- 66 The trick is to show that $\text{div} \mathbf{E} = 0$, $\text{curl} \mathbf{E} = 0$, thus $E \nabla^2 E = 0$, and from this, $\nabla^2 E^2 \geq 0$; there are thus no local electric field maxima in the absence of free charges. The same proof works for the magnetic field. However, bodies with dielectric constants *lower* than their environment *can* be levitated in static electric fields. An example are gas bubbles in liquids, as shown by T.B. JONES & G.W. BLISS, *Bubble dielectrophoresis*, Journal of Applied Physics **48**, pp. 1412–1417, 1977. Cited on page 390.
- 67 However, it is possible to levitate magnets if one uses a combination containing diamagnets. See A.K. GEIM, M.D. SIMON, M.I. BOAMFA & L.O. HEFLINGER, *Magnet levitation at your fingertips*, Nature **400**, pp. 323–324, 1999. Cited on page 390.
- 68 The first photographs of a single *ion* was in W. NEUHAUSER, M. HOHENSTATT, P.E. TOSCHEK & H. DEHMELT, Physical Review A **22**, p. 1137, 1980. See also D.J. WINELAND & W.M. ITANO, Physics Letters A **82**, p. 75, 1981, as well as F. DIETRICH & H. WALTER, Physical Review Letters **58**, p. 203, 1987.
For single *atoms*, see photographs in Z. HU & H.J. KIMBLE, Optics Letters **1**, p. 1888, 1994, F. RUSCHEWITZ, D. BETTERMANN, J.L. PENG & W. ERTMER, Europhysics Letters **34**, p. 651, D. HAUBRICH, H. SCHADWINKEL, F. STRAUCH, B. UEBERHOLZ, R. WYNANDS & D. MESCHEDÉ, Europhysics Letters **34**, p. 663, 1996. Cited on page 390.
- 69 See for example MARK BUCHANAN, *And God said...let there be levitating strawberries, flying frogs and humans that hover over Seattle*, New Scientist pp. 42–43, 26 July 1997, or C. WU, *Floating frogs*, Science News **152**, pp. 632–663, 6 December 1997, and *Molecular Magnetism takes off*, Physics World April 1997, page 28. The experiments by Andre Geim, Jan Kees

- Maan, Humberto Carmona and Peter Main were made public by P. RODGERS, *Physics World* **10**, p. 28, 1997. Some of the results can be found in M.V. BERRY & A.K. GEIM, *Of flying frogs and levitrons*, *European Journal of Physics* **18**, pp. 307–313, 1997. See also their <http://www-hfml.sci.kun.nl/hfml/levitate.html> web site. Cited on page 391.
- 70** The well-known toy allows levitation without the use of any energy source and is called the ‘Levitron’. It was *not* invented by Bill Hones of Fascination Toys & Gifts in Seattle, as the <http://www.levitron.com> web site explains. The toy is discussed by RON EDGE, *Levitation using only permanent magnets*, *Physics Teacher* **33**, p. 252, April 1995. It is also discussed in M.V. BERRY, *The LevitronTM: an adiabatic trap for spins*, *Proceedings of the Royal Society A* **452**, pp. 1207–1220, 1996, (of Berry’s phase fame) as well as by M.D. SIMON, L.O. HEFLINGER & S.L. RIDGEWAY, *Spin stabilized magnetic levitation*, *American Journal of Physics* **65**, pp. 286–92, 1997, and by T.B. JONES, M. WASHIZU & R. GANS, *Simple theory for the Levitron*, *Journal of Applied Physics* **82**, pp. 883–889, 1997. Cited on page 391.
- 71** The drill trick and the building of a Levitron are described in the beautiful lecture script by JOSEF ZWECK, *Physik im Alltag*, Skript zur Vorlesung im WS 1999/2000 der Universität Regensburg. Cited on page 391.
- 72** The prediction about quantized levitation is by STEPHEN B. HALEY, *Length quantization in levitation of magnetic microparticles by a mesoscopic superconducting ring*, *Physical Review Letters* **74**, pp. 3261–3264, 1995. The topic is discussed in more detail in STEPHEN B. HALEY, *Magnetic levitation, suspension, and superconductivity: macroscopic and mesoscopic*, *Physical Review B* **53**, p. 3506, 1996, reversed in order with STEPHEN B. HALEY, *Quantized levitation of superconducting multiple-ring systems*, *Physical Review B* **53**, p. 3497, 1996, as well as STEPHEN B. HALEY, *Quantized levitation by multiply-connected superconductors*, LT-21 Proceedings, in *Czechoslovak Journal of Physics* **46**, p. 2331, 1996. In 1998, there was not yet an experimental confirmation (Stephen Haley, private communication). Cited on page 391.
- 73** All the illusions of the flying act look as if the magician is hanging on lines, as observed by many, including the author. (Photographic flashes are forbidden, a shimmery background is set up to render the observation of the lines difficult, no ring is ever actually pulled over the magician, the aquarium in which he floats is kept open to let the fishing lines pass through, always the same partner is ‘randomly’ chosen from the public, etc.) Information from eyewitnesses who have actually seen the fishing lines used by David Copperfield explains the reasons for these setups. The usenet news group `alt.magic.secrets`, in particular Tilman Hausherr, was central in clearing up this issue in all its details, including the name of the company which made the suspension mechanism. Cited on page 391.
- 74** R. BUDDAKIAN, K. WENINGER, R.A. HILLER & SETH J. PUTTERMAN, *Picosecond discharges and stick-slip friction at a moving meniscus of mercury in glass*, *Nature* **391**, pp. 266–268, 15 January 1998. See also *Science News* **153**, p. 53, 24 January 1998. Cited on page 392.
- 75** HENK SWAGTEN & REINDER COEHOORN, *Magnetische tunneljuncties*, *nederlands tijdschrift voor natuurkunde* **64**, pp. 279–283, november 1998. Cited on page 392.
- 76** H. OHNO & al., *Nature* 21–28 December 2000. Cited on page 393.
- 77** This effect was discovered by GEERT RIKKEN, BART VAN TIGGELEN & ANJA SPARENBERG, *Lichtverstrooiing in een magneetveld*, *nederlands tijdschrift voor natuurkunde* **63**, pp. 67–70, maart 1998. Cited on page 394.
- 78** VITALIJ PECHARSKY & KARL A. GSCHNEIDNER, *Giant magnetocaloric effect in Gd₅(Si₂Ge₂)*, *Physical Review Letters* **78**, pp. 4494–4497, 1995, and, from the same authors, *Tunable magnetic regenerator alloys with a giant magnetocaloric effect for magnetic refrigeration from ~20 to ~2990 K*, *Applied Physics Letters* **70**, p. 3299, 1997. Cited on page 394.

- 79** A. AJDARI, *Electro-osmosis on inhomogeneously charged surfaces*, Physical Review Letters **75**, pp. 755–758, 1995. Cited on page **395**.
- 80** M.J. AITKEN, *Thermoluminescence dating*, Academic Press, London, 1985. The precision of the method is far worse than C14 dating, however, as shown by H. HUPPERTZ, *Thermolumineszenzdatierung: eine methodologische Analyse aufgrund gesicherter Befunde*, Peter Lang Verlag, 2000. Cited on page **396**.
- 81** This effect was discovered by J.N. HUIBERTS, R. GRIESSEN, J.H. RECTOR, R.J. WIJNGARDEN, J.P. DEKKER, D.G. DE GROOT & N.J. KOEMAN, *Yttrium and lanthanum hydride films with switchable optical properties*, Nature **380**, pp. 231–234, 1996. Cited on page **396**.
- 82** See any book on thermostatics, such as LINDA REICHL, *A modern course in statistical physics*, Wiley, 2nd edition, 1998. Cited on page **398**.
- 83** The sun emits about $4 \cdot 10^{26}$ W from its mass of $2 \cdot 10^{30}$ kg, about 0.2 mW/kg; a person with an average mass of 75 kg emits about 100 W (you can check this in bed at night) i.e. about 500 times more. Cited on page **398**.
- 84** See its <http://www.cie.co.at/cie> web site. Cited on page **398**.
- 85** P.D. JONES, M. NEW, D.E. PARKER, S. MARTIN & I.G. RIGOR, *Surface air temperature and its changes over the past 150 years*, Reviews of Geophysics **37**, pp. 173–199, May 1999. Cited on page **398**.
- 86** A picture of objects in a red hot oven and at room temperature is shown in C.H. BENNETT, *Demons, engines, and the second law*, Scientific American **255**, pp. 108–117, November 1987. Cited on page **399**.
- 87** WOLFGANG RINDLER, *Essential relativity – special, general, and cosmological*, revised second edition, Springer Verlag, 1977, page 247. There is also the beautiful paper by M. LE BELLAC & J.-M. LEVY-LEBLOND, *Galilean electrodynamics*, Nuovo Cimento B **14**, p. 217, 1973, which explains the possibilities one has and the problems one gets when trying to define the theory non-relativistically. Cited on page **400**.



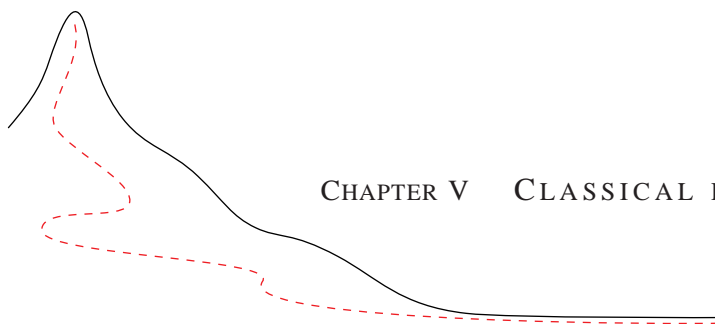

CHAPTER V CLASSICAL PHYSICS IN A NUTSHELL

The description of general relativity and classical electrodynamics concludes our walk through classical physics.* In order to see its limits, we summarize what we have learned about motion so far.

In every example of motion, we distinguish the moving and localized entity, the object, from the extended environment. For each of them we distinguish the fixed, intrinsic properties from the varying state.

Looking for all the *fixed, intrinsic* aspects of objects, we find that all sufficiently small objects or particles are described completely by their mass and their electric charge. There is no magnetic charge. In summary, mass and electric charge are the only localized intrinsic properties of classical, everyday objects. Both mass and electric charge are defined by the accelerations they produce around them. Both quantities can vary continuously, are conserved, and can be added. They are thus described by real numbers. Mass, in contrast to charge, is always positive. Both mass and charge describe the interaction of particles with the environment, i.e. with fields, and thus indirectly with other particles. Extended objects are described by continuous mass and charge distributions.

Looking for all *varying* aspects of objects, i.e. for their state, we find that we can describe them completely, at each instant of time, using only two basic aspects: the momentum and the position. Momentum and position can vary continuously in amount and orientation; observing how these aspects are described by different observers, we find that they are completely characterized by three-dimensional vectors. The set of all possible states is called the phase space. The phase space is described by continuous manifolds. The state of large objects made of more than one constituent is given by the states of all its constituent particles. These particles make up all objects and somehow interact electromagnetically.

The state of a particle depends on the observer. However, the states of the same particle found by different observers are related: the relations are called the ‘laws’ of motion. For example, for different times they are called *evolution equations*, for different places and orientations they are called *transformation relations*, and for different gauges they are called *gauge transformations*.

Apart from the motion of massive objects, we observe motion of a massless entity: *radiation*. All types of radiation, such as light, radio waves, and their related forms, are travelling electromagnetic waves, and are described by same equations that describe the interaction of

* Others prefer to include in classical physics only *special* relativity; this is a matter of personal preference.

charged or magnetic objects. The speed of massless entities is the maximum possible speed and is the same for all observers. The *state* of radiation is described by the electromagnetic field strength. The *intrinsic properties* of radiation are the field strength, its polarization, and its coupling to matter. The motion of radiation describes the motion of images.

The *environment* is described by space and time coordinates. The three spatial and the single temporal coordinate characterize a curved space-time. Space-time turns out to be able to move as well, in form of gravity waves. Space and time are described by entities which are continuous, extended, and which allow to define distances. Their intrinsic properties are the number of dimensions, its signature, and its topology. Their state is given by the metric, which describes the local warpedness. The warpedness can change, so that it is fair to say that empty space can move like a wave.

We learned that our environment is finite in age. We learned the main lines of its history, and the fact that on large scales, the matter in the universe moves away from the surrounding matter. Finally we discovered that we do not know yet the large scale topology of our environment, nor do we know what happens at its spatial and temporal limits.

The motion of *objects* is described by several simple relations. First of all, no two objects can be at the same point at the same time. Secondly, masses move the way space-time tells them, and space moves the way masses tell it. This relation describes the motion of the stars, of thrown stones, of the tides, etc. Thirdly, mass is needed to break the conformal symmetry, and to distinguish space from time.

We learned that electromagnetism is necessary to define length and time intervals, that light travels at the maximum possible velocity, and that rest and free fall are the same, and that gravity is curved space-time. In summary, we learned that of the two naive types of object motion, namely motion due to interaction with space-time curvature and motion due to the electromagnetic field, only the latter is genuine.

We also saw that speeds in nature are bound from above by a universal constant c , and that length to mass ratios are bound from below by a universal constant $4G/c^2$.

Above all, classical physics showed us that motion, be it linear or rotational, be it that of matter, of radiation, or of space-time, is conserved. It is similar to a continuous substance: it is never destroyed, never created, and always only redistributed. Due to conservation, all motion, that of objects, of images, and of empty space, is predictable and reversible. Due to conservation of motion, time and space can be defined. We also found that classical motion is right-left symmetric. In summary, despite everyday experience, there are *no* surprises in nature.

The future of planet earth

Maybe nature shows no surprises, but still provides many adventures. On the 8th of march 2002, a 100 m sized body almost hit the earth. It passed at a distance of only 450 000 km. On impact, it would have destroyed a region of the size of Berlin. A few months earlier, a 300 m sized body missed the earth by 800 000 km; the record so far was in 1994, when the distance was only 100 000 km.*

* The web pages around cfa-www.harvard.edu/iau/lists/Closest.html provide more information on such events.

Several other disasters can be predicted by classical physics, as shown in Table 38. Most are problems facing humanity only in a distant future. Nevertheless, all are research topics.

Table 38 Some examples of disastrous motion of possible future importance

Critical situation	time scale in years from now
▪ end of physics	ca. 50 (ca. year 2050)
▪ ozone shield reduction	ca. 100
▪ rising ocean levels due to greenhouse warming	ca. 100-1000
▪ explosion of volcano in Greenland, leading to darkening of sky	unknown
▪ several magnetic north and south poles, allowing solar storms to disturb radio and telecommunications, to interrupt electricity supplies, to increase animal mutations, and to disorient migrating animals such as wales, birds and tortoises	ca. 800
▪ our interstellar gas cloud detaches from the solar systems, changing the size of the heliosphere, and thus auroras and solar magnetic fields	ca. 3000
▪ subsequent reversal of earth's magnetic field, with increased cosmic radiation levels and thus more skin cancers and miscarriages	unknown
▪ atmospheric oxygen depletion due to forest reduction and exaggerated fuel consumption	> 1000
▪ upcoming ice age	ca. 50 000
▪ possible collision with interstellar gas cloud assumed to be crossed by the earth every 60 million years, causing mass extinctions	ca. 50 000
▪ gamma ray burst from within our own galaxy, causing radiation damage to many living beings	between 0 and $5 \cdot 10^6$
▪ asteroid hitting the earth, generating tsunamis, storms, darkening sunlight, etc.	between 0 and $50 \cdot 10^6$
▪ neighbouring star approaching, starting comet shower through destabilization of Oort cloud and thus risk for life on earth	> 10^6
▪ instability of solar system	> $100 \cdot 10^6$
▪ low atmospheric CO ₂ content stops photosynthesis	> $100 \cdot 10^6$
▪ ocean level increase due to earth rotation slowing/stop	> 10^9
▪ temperature rise/fall (depending on location) due to earth rotation stop	> 10^9
▪ sun runs out of fuel, becomes red giant, engulfs earth	$5.0 \cdot 10^9$
▪ sun stops burning, becomes white dwarf	$5.2 \cdot 10^9$
▪ earth core solidifies, removing magnetic field and thus earth's cosmic radiation shield	$10.0 \cdot 10^9$
▪ nearby nova (e.g. Betelgeuse) bathes earth in annihilation radiation	unknown
▪ nearby supernova (e.g. Eta Carinae) blasts over solar system	unknown
▪ galaxy centre destabilizes rest of galaxy	unknown
▪ universe recollapses – if ever (see page 198 ff.)	> $20 \cdot 10^9$
▪ matter decays into radiation – if ever (see Appendix C)	> 10^{33}
▪ problems with naked singularities	unknown, controversial
▪ the vacuum becomes unstable	unknown, controversial

Nevertheless, we leave aside these literally tremendous issues and continue in our adventure.

The essence of classical physics

We can summarize classical physics with a simple statement: *classical physics is the description of nature using the concept of infinity*. All the descriptions of nature used so far, be they for motion, space, time or observables, assume that the infinitely small and the infinitely large exist. Special relativity, despite the speed limit, still allows infinite proper velocity; general relativity, despite its black hole limit, still allows to approach it as much as possible. Mathematically, both integrals and derivatives are abbreviations of an infinite number of intermediate steps.

However, this approach does not completely convince. Some results, such as the atomic structure of matter, make us question the existence of the infinitely small.

Why is our mountain ascent not finished yet?

No problem is so formidable that
you can't walk away from it.
Charles Schultz

At the end of the 19th century, both Albert Michelson and Oliver Lodge – two well-known, mainly experimental physicists working on electrodynamics – claimed that electrodynamics and Galilean physics implied that the major laws of physics were well known. Their statements are often quoted as examples of flawed predictions, especially since their very own experiments lead to the development of relativity, which they failed to anticipate.

But these victorian physicists overlooked another contradiction between electrodynamics and nature for which they have no excuse. In our walk so far we found that clocks and meter bars are necessarily based on matter and electromagnetism. But as we just saw, we do not understand the stability of matter yet. Matter is made of small particles, but the relation between these particles and electricity is not clear. This implies that we do not yet understand space and time, since both are defined with measurement devices made of matter. It is also not clear whether infinitely small quantities really exist. There is a challenge waiting, namely the second part of our mountain ascent. The prize is to understand interactions.

Only the study of interactions allows to settle a further question the 19th century overlooked: if motion is *conserved* in collisions, what exactly is *exchanged* between colliding bodies? The fascinating path towards the answer is almost purely a sequence of surprises.

Subsequently, we need to rethink electromagnetism, as well as the other interactions we will discover, in the presence of space-time curvature. This challenge forms the third and final part of our mountain ascent. There the adventure becomes truly mind boggling and almost incredible. The reason is simple: both remaining parts of our mountain ascent require an approach for the description of motion which we have not encountered yet: quantum theory.

Finally, we still have not resolved the issue we mentioned at the end of Galilean physics: we still are defining space-time with help of objects, and objects with help of space-time. That will be the high point of our ascent. To be well prepared, we first take a break.

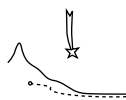

INTERMEZZO: THE BRAIN, LANGUAGE, AND THE HUMAN CONDITION

Physic ist wahrlich das eigentliche Studium des Menschen.*
Georg Christoph Lichtenberg (1742–1799)

Alles was überhaupt gedacht werden kann, kann klar gedacht werden.**
Ludwig Wittgenstein, *Tractatus*, 4.116

Typeset in
July 2002

In our quest for increased precision in the description of all motion around us, it is time to take a break, sit down and look back. In our walk so far, which led through general relativity and electrodynamics, we used several concepts without defining them. Such undefined concepts were, for example, ‘information’, ‘memory’, ‘measurement’, ‘set’, ‘number’, ‘infinity’, ‘existence’, ‘universe’, or ‘explanation’. They are common and important terms. In this intermezzo, we take a look at these concepts and try to give some simple, but sufficiently precise definitions, keeping them as provocative and entertaining as possible. For example: can you explain to your parents what a concept is?

Challenge 251

The reason for doing this is simple. We need these clarifications in order to get to the top of motion mountain. Many have lost their way because of lack of clear concepts. Physics has a special role in this case. All sciences have one result in common: every type of change observed in nature is a form of motion. In this sense, but in this sense *only*, physics, focusing on motion itself, forms the basis for all the other sciences. In other words, the search for the famed ‘theory of everything’ is an arrogant expression for the search for a *theory of motion*. Even though the knowledge of motion is basic, its precise description does not imply a description of ‘everything’: just try to solve a marriage problem using the Schrödinger equation to experience the difference.

Anyway, given the basic importance of motion, it is necessary that in physics all statements on observations be as precise as possible. For this reason, many thinkers have investigated physical statements with particular care, using all criteria imaginable. The list of criteria appears once one asks: physics being detailed prattle by curious people about moving things, which abilities does this task require? You might want to fill in the list yourself.

Challenge 268

All necessary abilities have been and still are investigated by researchers. The way the human species acquired the ability to chat about motion is studied by evolutionary biologists. Child psychologists study how the ability develops in a single human being. Physiologists, neurologists and computer scientists are concerned with the way the brain and the senses make this possible; linguists focus on the properties of language we use, while logicians, mathematicians and philosophers of science study the general properties of statements about nature. All of them investigate tools which are essential for the development of physics, for

* Physics truly is the proper study of man.

** ‘Everything that can be thought at all can be thought clearly.’ This and other sentences in this chapter by Ludwig Wittgenstein are from the equally short and famous *Tractatus logico-philosophicus*, written in 1918, first published in 1921; it has now been translated in many other languages.

understanding motion, and for specifying the undefined concepts listed above. Their fields structure this intermezzo.

Evolution

A hen is only an egg's way of making another egg.
Samuel Butler, *Life and habit*, 1877.

The evolution of the human species is a long story, which has been told in many excellent books. A summarizing table on the history of the universe is given in the chapter on general relativity. It is worth remembering the incredible history which has led to one's own existence, starting with the formation of atoms, of the galaxies, the stars, the planets, the moon, the atmosphere, the first cells, the water animals, the land animals, the mammals, the hominids, the humans, the ancestors, the family, and to oneself.

Ref. 1

See page 287

Ref. 2

The way the particles we are made of moved during this sequence, being blown through space, being collected on earth, becoming organized to form people, is one of the most awe-inspiring examples of motion. Remembering this fantastic sequence of motion every now and then can be an enriching experience.

Challenge 285

Biological evolution* in particular tells us a few important things. Without biological evolution, we would not be able to talk about motion; only moving bodies can study moving bodies. And evolution invented childhood. In this intermezzo we will discover that most concepts of classical physics are introduced already by little children, in the experiences they make while growing up.

Children and physics

Physicists also have a shared reality. Other than that, there isn't really a lot of difference between being a physicist and being a schizophrenic.
Richard Bandler

During childhood, everybody was a physicist. When one follows one's own memories backwards in time as far as one can, one reaches a certain stage, situated before birth, which forms the starting point of one's human experience. In that magic moment, one sensed somehow that apart from oneself, there is something else. The first observation one makes about the world is thus the recognition that one can distinguish two parts in it: oneself and the rest. This distinction is an example – perhaps the first – of a large number of 'laws of nature' one stumbles upon in one's lifetime. By discovering more and more distinctions one brings structure in the chaos of one's experience. One quickly finds out that the world is made of related parts, such as mama, papa, milk, earth, toys, etc.

Ref. 3

Later, when one learns to speak, one becomes fond of more difficult words, and one calls the surroundings the *environment*. Depending on the context, one calls the whole formed by oneself and the environment together the (physical) *world*, the (physical) *universe*, *nature*,

* An informative overview over the results of evolution, with the many-branched family tree that it produced, is given on the <http://phylogeny.arizona.edu/tree> web site. About the results of evolution for human beings, see the informative text by K. KUSCH & S. KUSCH, *Der Mensch in Zahlen*, Spektrum Akademischer Verlag, 2. Auflage, 2000.

or the *cosmos*. These concepts are not distinguished from each other in this walk;* they are all taken to designate the sum of all parts and their relations; they are simply taken here to designate the *whole*.

Challenge 302

From the moment of the first distinction onwards, one is ready to extract the numerous distinctions possible in the environment, the various parts of oneself, and the various types of interactions between all these. Distinguishing is the central ability which allows us to change our view from that of the world as *chaos*, i.e. as a big mess, to that of the world as a *system*, i.e. a structured set, in which parts are related in specific ways. (If you like precision, you may ponder whether the two choices of ‘chaos’ and ‘system’ are the only possible ones. We will return to this issue in the third part of our mountain ascent.)

See page 455

In particular, the observation of difference between oneself and the environment goes hand in hand with the recognition that one is not independent of the environment, but that one is firmly tied to it in various inescapable ways; one can fall, get hurt, feel warm, cold, etc. Such relations are called *interactions*. Interactions express the observation that even though the parts of nature can be distinguished, they cannot be isolated. In other words, interactions describe the difference between the whole and the sum of its parts. No part can be defined without its relation to its environment.

Interactions are not arbitrary; just take touch, smell, or sight as examples. They differ in reach, in strength, and in consequences. We call the characteristic aspects of interactions *patterns of nature*, or *properties of nature*, or *rules of nature*, or equivalently, with their historical but unfortunate name, ‘*laws of nature*’. The term ‘law’ stresses their general validity but also implies design, aim, coercion and punishment for infringement; however, no design, no aim, nor any coercion is implied in the properties of nature, nor is infringement possible. The ambiguous term ‘law of nature’ was made popular by René Descartes (1596–1650) and has been adopted enthusiastically because it in turn gave more weight to the laws of the state – which were far from perfect at that time – and to those of other organizations – which rarely are. The expression is an anthropomorphism coined by an authoritarian world view, suggesting that nature is ‘governed.’ We will therefore use the term as rarely as possible in our walk, and then, always between double, ironical, quotes. Nature cannot be forced in any way. The ‘laws’ of nature are not obligations for nature or its parts, they are obligations only for physicists and all other people: the patterns of nature oblige us to use certain descriptions and to discard others. Whenever one says ‘laws govern nature’ one is babbling nonsense; the correct expression is *rules describe nature*.

During childhood one learns to distinguish among interactions with the environment (or *perceptions*); some are shared with others, and called *observations*, others are uniquely personal ones, and called *sensations*.**

Often a slightly different criterion of ‘sharedness’ is used to divide the world into ‘reality’ and ‘imagination’ or ‘dreams’. Our walk will show that this distinction is not essential,

* The differences in usage can be deduced from their linguistic origins. ‘World’ is derived from old Germanic ‘wer’ – person – and ‘ald’ – old – and originally means ‘lifetime’. ‘Universe’ is from Latin, and designates the one – ‘unum’ – which one sees turning – ‘vertere’, and refers to the starred sky at night which turns around the polar star. ‘Nature’ is also from Latin, and means ‘what is born’. ‘Cosmos’ is from Greek κόσμος and originally means ‘order’.

** A child not able to make this distinction among perceptions – and thus unable to lie – almost surely develops or already suffers from *autism* as recent psychological research showed.

Ref. 4

This is a section of the freely downloadable e-textbook

Motion Mountain

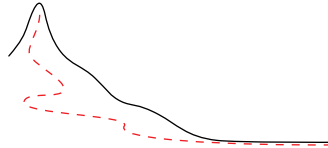

Hiking beyond space and time along the concepts of modern physics

available at
www.motionmountain.org

Copyright © 1997, 1998, 1999, 2000, 2001, 2002 by Christoph Schiller

To the kind reader

In exchange for getting this section for free, I ask you for a short email on some of the following:

- Which page was boring?
- Did you find any mistakes?
- What else were you expecting?
- What was hard to understand?

Of course, any other suggestion is welcome. This section is part of a physics text written over many years. The text lives and grows through the feedback from its readers, who help to improve and to complete it. For a particularly useful contribution (send it in english, italian, dutch, german, spanish, portuguese, or french) you will be mentioned in the foreword of the text, or receive a small reward, or both.

Enjoy!

Christoph Schiller
cs@motionmountain.org

Challenge 319

provided that one stays faithful to the quest for ever increasing precision: we will find that the description of motion we are looking after does not at all depend on whether the world is 'real' or 'imagined,' 'personal' or 'public.'

Ref. 5 Humans grow fond of their ability to distinguish parts, which in other contexts they also call *details*, *aspects*, or *entities*, and of their ability to associate them, i.e. to observe the *relations* between them. Human call this activity *classification*. Colours, shapes, objects, mother, places, people, ideas, are some of the entities one discovers first.

Our anatomy provides a handy tool to make efficient use of these relations: *memory*. A lot of input gets stored in it and is then called *experience*. Memory is a tool used by the young child to organize its world, and to achieve security in the chaos of life.

Jean Piaget was the first to describe the influence of the environment on the concepts a child forms. Step by step, children learn that objects are localized in space, that space has three dimensions, that objects fall, that collisions produce noise, etc. In particular, Piaget showed that space and time are not a priori concepts, but result from the interactions of any child with its environment.*

Ref. 7 Around the time a child goes to school, it starts to understand the idea of *permanence of substances*, e.g. liquids, and the concept of *contrary*. Only at that stage its subjective experience becomes *objective*, with abstract comprehension. Later on, around puberty, the description of the world by children stops to be animistic: before, the sun, a brook, a cloud are *alive*. In short, only after puberty a human is ready for physics.

Even though everybody was a physicist in his youth, most people only remain *classical* physicists. In this adventure we go on, using all possibilities of a toy that nature provides us: the brain.

Experience is the name everyone gives to their mistakes.

* An overview of the origin of developmental psychology is given by J.H. FLAVELL, *The developmental psychology of Jean Piaget*, 1963. This work summarizes the observations by the French speaking Swiss Jean Piaget (1896–1980), the central figure of the field. He was one of the first researchers to look at child development in the same manner that a physicist looks at nature: carefully observing, taking notes, making experiments, extracting hypotheses, testing them, deducing theories. His astonishingly numerous publications, based on his extensive observations, cover almost all stages of child development. His central contribution is the detailed description of the stages of development of the cognitive abilities of humans, the formation of basic concepts, from his way of thinking, his ability to talk, etc., result from the continuous interaction between the child and the environment.

In particular, Piaget described the way children first learn that they are different from the external environment, and how they then learn about the physical properties of the world. Of his many books related to physical concepts, two especially related to the topic of this walk are J. PIAGET, *Les notions de mouvement et de vitesse chez l'enfant*, Presses Universitaires de France, 1972 and *Le développement de la notion de temps chez l'enfant*, Presses Universitaires de France, 1981, this last book being born from a suggestion by Albert Einstein. These texts should be part of the reading of every physicist and science philosopher interested in these questions.

Piaget also describes how in children the mathematical and verbal intelligence derives from sensomotorial, practical intelligence, which itself stems from the habits and acquired associations to construct new concepts. Practical intelligence requires the system of reflexes provided by the anatomical and morphological structure of our organism. Thus his work shows in detail that our faculty for mathematical description of the world is based, albeit indirectly, on the physical interaction of one's organism with the world.

Ref. 6 Some of his opinions on the importance of language in the development are now being revised, notably through the rediscovery of the work of Lev Vigotsky, who argues that all higher mental abilities, emotions, recollective memory, rational thought, voluntary attention and self-awareness, are not innate, but learned. This learning takes place through language and culture, and in particular through the process of talking to oneself.

Oscar Wilde (1854, Dublin–1900, Paris), *Lady Windermere's Fan*.

Why a brain?

Denken is bereits Plastik. *

Joseph Beuys (1920–1986), sculptor. Ref. 8

Numerous observations show that sense input is processed, i.e. classified, stored, and retrieved in the brain. Notably, lesions of the brain can lead to loss of part or all of these functions. Among the important consequences of these basic abilities of the brain are thought and language. All such abilities result from the construction, from the ‘hardware’ of the brain. Ref. 9

Systems with the ability to deduce classifications from the input they receive are called *classifiers*, and are said to be able to *learn*. Our brain shares this property with many complex systems; the brain of many animals, but also certain computer algorithms, e.g. the so-called ‘neural networks’, are examples of such classifiers. Such systems are studied in several fields, from biology to neurology, mathematics and computer science. ** Classifiers have the double ability to discriminate and to associate; both are fundamental to thinking. Ref. 10

Machine classifiers have a lot in common with the brain. As an example, following an important recent hypothesis in evolutionary biology, the necessity of cooling the brain in an effective way is responsible for the upright, bipedal walk of humans. The brain needs a powerful cooling system to work well. In this it resembles modern computers, which usually have powerful fans or even water cooling systems built into them. It turns out that the human species has the most powerful cooling system of all mammals. The upright posture allowed the air to cool the body more effectively in the tropical environment where humans evolved. To allow even better cooling, humans also lack most of their body hair, except on their head, where it protects the brain from direct heating by the sun. Ref. 11

All classifiers are built from smallest classifying entities, sometimes large numbers of them. Usually, the smallest units can classify input into only two different groups. The larger the number of these entities, often called ‘neurons’ by analogy to the brain, the more sophisticated classifications can be produced by the classifier. *** Classifiers thus work by applying more or less sophisticated combinations of ‘same’ and ‘different’. The distinction by a child of red and blue objects is such a classification; the distinction of compact and non-compact gauge symmetry groups in quantum theory is a more elaborate classification, but relies on the same fundamental ability.

In all classifiers, the smallest classifying units interact with each other. Often these interactions are channelled via connections, and the set is then called a *network*. In these connections, signals are exchanged, via moving objects, such as electrons or photons. Thus one arrives at the conclusion that the ability of the brain to classify the physical world, for example to distinguish moving objects interacting with each other, is a consequence of the

* Thinking is already sculpture.

** A good introduction into the study of classifiers is ...

*** A good introduction into neural nets is J. HERTZ, A. KROGH & R. PALMER, *Introduction to the theory of neural computation*, Addison Wesley, Redwood City, USA, 1991.

fact that it itself consists of moving objects interacting with each other. Without a powerful classifier, humans would not have become such a successful animal species. And only the motion inside our brain allows us to talk about motion in general.

See page 612 Numerous researchers are identifying the parts of the brain used when different intellectual tasks are performed. The experiments become possible with the technique of magnetic resonance imaging and other methods. Other researchers study how thought processes can be modelled from the brain structure. Neurology is still making regular progress. In particular, it is steadily destroying the belief that thinking is *more* than a physical process. This belief results from personal fears, as you might want to test by introspection. It will disappear as time goes by.

Challenge 336

What is information?

These thoughts did not come in any verbal formulation.
I rarely think in words at all.
A thought comes, and I may try to express it in words afterward.
Albert Einstein (1879–1955).

We started by saying that studying physics means to talk about motion. To talk means to transmit information. Can information be measured? Can one measure the progress of physics in this way? Is the universe made of information?

Information is the result of classification. A classification is the answer to one or to several yes-no questions. Such yes-no questions are the simplest classifications possible; they provide the basic *units* of classification, from which all others can be built. The simplest way to measure information is therefore to count the implied yes-no questions, the *bits*, leading to it. Are you able to say how many bits are necessary to define the place where you live? Obviously, the number of bits depends on the set of questions one starts with; that could be the names of all streets in a city, the set of all coordinates on the surface of the earth, the names of all galaxies in the universe, the set of all letter combinations in the address.* A variation of the latter method is used in computers. For example, the story of this walk required about fifty million bits. But since the amount of information in a normal letter depends on the set of questions one starts with, it is not possible to define a precise measure for information in this way.

Challenge 353

The only way to measure information precisely is to take the largest possible set of questions one can ask about a system. In that case, the amount of unknown information is called entropy, a concept we encountered already. Now you are able to deduce yourself whether it is really possible to measure the advance of physics.

See page 152
Challenge 387

Since categorization is an activity of the brain and other, similar classifiers, information as defined here is a concept that applies to the result of activities by people and by other classifiers. In short, information is produced when talking about the universe – the universe itself is *not the same* as information. There is an increasing number of publications based on the opposite of this view, a more and more frequent conceptual short circuit. Any transmission of information implies an interaction; physically speaking, this means that any information

* The number of required yes-no questions is rather different for the different cases. What is the most efficient one you can think of?

Challenge 370

needs *energy* for transmission and *matter* for storage. Without either of them, there is no information. In other words, the universe, with its matter and energy, has to exist *before* transmission of information is possible. Saying that the universe is made of information is as sensible as saying that it is made of toothpaste.

The aim of physics is to give a *complete* classification of all types and examples of motion, in other words, to know everything about motion. Is this possible? Are you able to find an argument against this endeavour?

Challenge 404

What is memory?

The brain is my second favorite organ.

Woody Allen

Memory is the collection of records of perceptions. The production of such records is the essential aspect of observation. The storage of records can take place in human memory, i.e. in the brain, or in machine memory, as in computers, or in object memory, such as notes on paper. Without memory, there is no science, no life – since life is based on the records inside the DNA – and especially, no fun, as proven by the sad life of those who loose it.

Ref. 9

Obviously every record is an object. But when does an object qualify as a record? A signature can be the record of the agreement on a commercial transaction. A single small dot of ink is not a record, because it could have appeared by mistake, for example by handling a pen. In contrast, it is improbable that a quantity of ink falls on paper exactly in the shape of a signature – except of course for the signatures of physicians. Simply speaking, a *record* is any object, which, in order to be copied, has to be forged. More precisely, a record is an object or a situation which cannot arise nor disappear by mistake or by chance. Our personal memories, be they images or voices, have the same property; we usually can trust them, because they are so detailed that they cannot have arisen by chance or by uncontrolled processes in our brain.

Can one estimate the probability for a record to appear or disappear by chance? Yes, one can. Every record is made of a characteristic number N of small entities, for example the number of the possible ink dots on paper, the number of iron crystals in a cassette tape, the electrons in a bit of computer memory, the silver iodide grains in a photographic negative, etc. The chance disturbances in any memory are due to internal fluctuations, also called *noise*. Noise makes the record unreadable; it can be dirt on a signature, thermal magnetization changes in iron crystals, electromagnetic noise inside a solid state memory, etc. Noise is found in all classifiers, since it is inherent in all interactions and thus in all information processing.

It is a general property that internal fluctuations due to noise decrease as the size, i.e. the number of components of the record is increased. In fact, the probability p_{mis} for a misreading or miswriting of a record changes as

Challenge 421

$$p_{\text{mis}} \sim 1/N \quad . \quad (381)$$

This relation is a consequence of the fact that for large numbers, the normal distribution is a good approximation of almost any process, and that the width of the normal distribution,

which determines the probability of record errors, grows less rapidly than its integral when the number of entities is increased. (Are you able to confirm this?)

Challenge 438

We conclude that any good record must be made from a *large* number of entities. The larger the number is, the less sensitive the memory is to fluctuations. Now, a system of large size with small fluctuations is called a (*physical*) *bath*. Only baths make memories possible. In other words, every record contains a bath. We conclude that any *observation* of a system is the interaction of that system with a bath. This connection will be used several times in the following, in particular in quantum theory. When the record is produced by a machine, one usually calls the ‘observation’ a (*generalized*) *measurement*. Are you able to specify the bath in the case of a person watching a landscape?

Challenge 455

From the preceding discussion we can deduce the following surprising statement: since we have such a prodigious memory at our disposition, we can deduce that we are made of many small parts. And since records exist, the world must be made of a large number of small parts as well. No microscope is needed to confirm the existence of molecules or similar small entities; these tools are only needed to determine the *sizes* of these particles. Their existence can be deduced simply from the fact that we have memory. (Of course, another argument proving that matter is made of smallest parts is the ubiquity of noise itself.)

See page 144

A second conclusion was popularized in the late 1980s. Writing a memory does not produce entropy; it is possible to store information into a memory without increasing entropy. However, entropy is produced in every case that the memory is *erased*. It turns out that the (minimum) entropy created by erasing one bit is given by

Challenge 472

$$S_{\text{per erased bit}} = k \ln 2 \quad . \quad (382)$$

As is well known, one needs energy to reduce the entropy of a system. By the way, *dreaming* is connected with the erasing and reorganization of information. Could that be a reason explaining that when one is very tired, without any energy left, one does not dream as much as in other cases?

Challenge 489

Entropy is thus necessarily created when one forgets. This is evident when one imagines that forgetting is similar to the deterioration of an ancient manuscript. Entropy increases when the manuscript is not readable any more, since the process is irreversible and dissipative. * Another way to see this is to recognize that to clear a memory, e.g. a magnetic tape, one has to put energy into it, and thus to increase its entropy. Conversely, *writing* into a memory can often *reduce* entropy; we remember that signals, the entities which write memories, carry negative entropy. For example, the writing of magnetic tapes usually reduces their entropy.

Ref. 12

The capacity of the brain

Computers are boring. They can give only answers.

Ref. 13

* As Wojtek Zurek explains so clearly, the entropy created inside the memory is the main reason that a Maxwell’s demon cannot reduce the entropy of two volumes of gases by opening a door between them in such a way that fast molecules accumulate on one side, and slow molecules accumulate on the other.

Want to play demon? Click on the [http:// www.wolfenet.com/ zeppelin/maxwell.htm](http://www.wolfenet.com/zeppelin/maxwell.htm) web site.

Attributed to Pablo Picasso

The human brain is built in a way that its fluctuations cannot destroy its contents. The brain does this by literally growing connections, called *synapses*, between its various *neurons*, which are the cells doing the signal processing, i.e. the basic classification. The neuron is the basic processing element of the brain. It can do only two things: to fire and not to fire. (It is possible that the time at which a neuron fires also carries information; this question is not settled yet.) The neuron fires depending on its input, which usually comes from hundreds of other neurons, via the synapses. A neuron is thus an element which can distinguish the inputs it receives into two cases: those leading to firing and those which do not. Neurons are thus classifiers of the simplest type, able to distinguish between two situations only.

Ref. 14, 15

Every time we store something in our long term memory, like the phone number of a friend, new synapses are grown or the connection strength of existing synapses is changed. The connections between the neurons are much stronger than the fluctuations in the brain. Only strong disturbances, such as a blocked blood vessel or a brain lesion, can destroy neurons, and then lead to loss of memory.

As a whole, the brain is an extremely efficient memory. Despite intense efforts, engineers have not yet been able to build a memory with the capacity of the brain in the same volume. This memory capacity is easily estimated. By multiplying the number of neurons, about 10^{11} , by the average number of synapses per neuron, about 100, and also by the estimated number of bits stored in every synapse, about 10, one arrives at a storage capacity for the brain of about

$$M_{\text{rewritable}} \approx 10^{14} \text{ bit} \approx 10^4 \text{ GByte} \quad . \quad (383)$$

Note that evolution has managed to put as many neurons in the brain as there are stars in the galaxy, and that if one adds all the synapse lengths, one gets a total length of about 10^{11} m, which corresponds to the distance to from the earth to the sun. Our brain truly is *astronomically* complex.

The large storage capacity* of the brain shows that human memory is filled by the environment and is not inborn: one human ovule plus one sperm have a mass of about 1 mg,

* In practice, the capacity seems almost without limit, since the brain frees memory every time it needs some, by *forgetting* older data, e.g. during sleep. Note that this standard estimate of 10^{14} bits is not really correct! It assumes that the only component storing information in the brain is the synapse strength. Therefore it only measures the *erasable* storage capacity of the brain. In fact, information is also stored in the structure of the brain, i.e. in the exact configuration in which cell is connected to other cells. Most of this structure is fixed at the age of about two years, but continues at a smaller level for the rest of one's life. Assuming that for each of the N cells with n connections there are fn connection possibilities, this *write once* capacity of the brain can be estimated as roughly $N\sqrt{fn}fn \log fn$ bits. For $N = 10^{11}$, $n = 10^2$, $f = 6$, this gives

Challenge 506

$$M_{\text{writeonce}} \approx 10^{16} \text{ bit} \approx 10^6 \text{ GByte} \quad . \quad (384)$$

By the way, even though the brains of sperm whales and of elephants can be five to six times as heavy as those of humans, the number of neurons and of their connections, and thus the capacity, seems to be highest for humans.

Sometimes it is claimed that people use only between 5% or 10% of their brain capacity. This myth, which goes back to the 19th century, would imply that one is able to measure the actually stored data in the brain and compare it with its capacity to an impossible accuracy. It also implies that nature would develop and maintain an organ with 90% overcapacity, wasting all the energy and material to build, repair, and maintain it.

which corresponds to about $3 \cdot 10^{16}$ atoms. Obviously, fluctuations make it impossible to store 10^{16} bits in it. In fact, nature stores only about $3 \cdot 10^9$ bits in the genes of an ovule, using 10^7 atoms per bit. In contrast, a typical brain has a mass of 1.5 to 2 kg, containing about 5 to $7 \cdot 10^{25}$ atoms, which makes it as efficient as the ovule. The difference between the number of bits in human DNA and of those in the brain nicely shows that practically all information stored in the brain is taken from the environment, and cannot be of genetic origin, even allowing for smart decompression of stored information.

In total, all these tricks used by nature result in the most powerful classifier yet known. Are there any limits to the brain's capacity to memorize and to classify? With the tools that humans have developed to expand the possibilities of the brain, such as paper, writing, and printing to help memory, and the numerous tools to simplify and to abbreviate classifications explored by mathematicians, the practical limit to brain classification is given by the time spent practising it.*

Ref. 16

The brain is unparalleled also in its processing capacity. This is most clearly demonstrated by the most important consequence deriving from memory and classification: thought and language. Indeed the many types of thinking or talking we use, such as comparing, distinguishing, remembering, recognizing, connecting, describing, deducing, explaining, imagining etc., all describe different ways to classify memories or perceptions. In the end all thinking and talking directly or indirectly classify observations. But how far are computers from achieving this! To talk to a computer program, such as to the famous program Eliza which mimics a psychoanalyst or to its improvements, is still a disappointing experience. To understand the reasons, one might ask:

What is language?

Reserve your right to think, for even to think wrongly
is better than not to think at all.
Hypatia of Alexandria (ca. 355–415)

Ein Satz kann nur sagen, *wie* ein Ding ist, nicht *was* es ist.**
Ludwig Wittgenstein, *Tractatus*, 3.221

Language possibly is the most fantastic gift of human nature. Using their ability to produce sounds and to put ink on paper, people attach certain *symbols*,*** also called *words* or *terms* in this context, to the many partitions they specify with help of their thinking. Such a categorization is then said to define a *concept*, or *notion*, and is then set in *italic typeface* in this

* Without tools, there are strict limits, of course. The two-millimetre thick cerebral cortex of humans has a surface of about four sheets of A4 paper, a chimpanzee's yields one sheet, and a monkey's the size of a postcard. It is estimated that the total intellectually accessible memory is of the order of 1 GB, though with a large error.

** Propositions can only say *how* things are, not *what* they are.

*** A symbol is a type of *sign*, i.e. an entity associated by some convention to the object it refers. Following Charles Peirce (1839–1914) – see <http://www.peirce.org> – the most original philosopher born in the United States, a symbol differs from an *icon* (or *image*) and from an *index*, which are also attached to objects by convention, in that it does not resemble the object, as an icon does, and in that it has no contact with the object, as is the case for an index.

text. A standard set of concepts forms a language.* In other words, a (*human*) *language* is a standard way of symbolic interaction between people.** Languages can be based on facial expressions, on gestures, on spoken words, on whistles, on written words, etc. The use of *spoken* language is considerably younger than the human species; it seems that it appeared only about one hundred thousand years ago. Written language is even younger, namely only about six thousand years old. But the set of concepts used, the *vocabulary*, is still expanding. For single humans, the understanding of language begins soon after birth (perhaps even before), its active use begins at around a year of age, the ability to read can start as early as two, and personal vocabulary continues to grow as long as curiosity is alive.

Physics being lazy chat about motion, it needs language as essential tool. Of the many aspects of language, from literature to poetry, from jokes to military orders, from expressions of encouragement, dreams, love and emotions, physics uses only a small and rather special segment. This segment is defined by the inherent restriction to talk about motion. Since motion is an observation, i.e. an interaction with the environment that other people experience in the same way, this choice puts a number of restrictions on the contents – the vocabulary – and on the form – the grammar – of such discussions.

For example, from the definition that observations are shared by others, one gets the requirement that the statements describing them must be translatable into all languages. But when can a statement be translated? On this question two extreme points of view are possible; the first maintains that *all* statements can be translated, since it follows from the properties of human languages that each of them can express every possible statement. In this view, only sign systems which allows to express the complete spectrum of human messages form a *human language*. This property distinguishes spoken and sign language from animal languages, such as the signs used by apes, birds or honey bees, and also from computer languages, such as Pascal or C. With this meaning of language, all statements can be translated by definition.

It is more challenging for a discussion to follow the opposing view, namely that precise translation is possible only for those statements which use terms, word types and grammatical structures found in *all* languages. Linguistic research has invested considerable effort in the distillation of phonological, grammatical, and semantic *universals*, as they are called, from the around 7000 languages thought to exist today.***

* The recognition that language is based on a partition of ideas, using the various differences between them to distinguish them from each other, goes back to the Swiss Ferdinand de Saussure (1857–1913), who is regarded as the founder of linguistics. His textbook *Cours de linguistique générale*, Editions Payot, Paris, 1985, has been the reference work of the field for over half a century. Note that Saussure, in contrast to Peirce, prefers the term ‘sign’ to ‘symbol’, and that his definition of the term ‘sign’ includes also the object it refers to.

** For a slightly different definitions, and a wealth of other interesting information about language, see the beautiful book by DAVID CRYSTAL, *The Cambridge encyclopedia of language*, Cambridge University Press, 1987.

*** A comprehensive list with 6 700 languages (and with 39 000 language and dialect names) can be found on the world wide web site by Barbara Grimes, *Ethnologue – languages of the world*, to be found at the address <http://www.sil.org/ethnologue> or in the printed book of the same name.

It is estimated that $15\,000 \pm 5\,000$ languages have existed in the past.

In today’s world, and surely in the sciences, it is often sufficient to know one’s own language plus English. But never let the failure of good command of English hamper your curiosity. A well known physics journal has been published with an English language mistake in its title for dozens of years: ‘Progress of [sic] theoretical physics’; it provides a prime example of collective stubbornness. We don’t want to follow it; we want to improve

The investigations into the *phonological* aspect, which showed for example that every language has at least two consonants and two vowels, does not provide any material for the discussion of translation. * Studying the *grammatical* (or *syntactic*) aspect, one finds that all languages use smallest elements, called ‘words’, which they group into sentences. They all have pronouns for the first and second person, ‘I’ and ‘you’, and always contain nouns and verbs. All languages use *subjects* and *predicates*, or, as one usually says, the three entities *subject*, *verb* and *object*, though not always in this order. Just check the languages you know.

Challenge 523

On the *semantic* aspect, the long list of lexical universals, i.e. words that appear in all languages, such as ‘mother’ or ‘sun’, has recently been given a structure by the discovery of semantic primitives. The list of *universal semantic primitives* is the result of the search of the building blocks from which all concepts can be built, in the sense that the definition of any concept can be given using only previously defined concepts, and these in turn can be defined with previously defined concepts and so forth, until one reaches a fundamental level consisting only of the primitives themselves. The list thus results from the study of the many existing languages and from the way concepts are built upon each other. In November 1992, it contained the following primitives:

Table 39 Semantic primitives, following Anna Wierzbicka

I, you, someone, something; people	[substantives]
this, the same, two, all, much (many); one	[determiners and quantifiers]
know, want, think, feel, say	[mental predicates]
do, happen	[agent, patient]
good, bad	[evaluative]
big, small	[descriptors]
very	[intensifier]
can, if (would)	[modality, irrealis]
because	[causation]
no (not)	[negation]
when, where, after (before), under (above)	[time and place]
kind of, part of	[taxonomy, partonomy]
like	[hedge/prototype]

Following the life-long research of Anna Wierzbicka, all these concepts exist in all languages of the world she and her research group was able to study. She showed that in every language all other concepts can be defined with help of this basic set. We note that ‘true’ and ‘false’ are not included in the list, because they are seen as composite concepts. We also note that ‘motion’ is implicitly contained in the verbs ‘do’ and ‘happen’. Also the other verbs in the list can be seen as examples of motion. Also linguistically, motion is at the basis of human experience.

Ref. 18

See page 444

The definition of language given above, namely a means of communication which allows to express everything one wants to say, can thus be refined: a *human language* is any set

our description of nature continuously, and continuously correct any mistakes: in this way we can enjoy life more and more. Since English is the language with the largest number of words, learning it well is also a greater challenge than for most of the others.

Ref. 17

* Studies centre on topics such as the fact that in many languages the word for ‘little’ contains an ‘i’ (or high pitched ‘e’) sound: petit, piccolo, klein, tiny, pequeño, chiisai; exceptions are: small, parvus.

of concepts which includes the semantic primitives. For a physicist, with his aim to talk in as few words as possible, obviously such a long list is not satisfying, especially when he notes that all these concepts are about interactions between different parts of nature. One of the aims of our walk is to arrive at a list consisting of only one or two basic concepts. To appreciate this aim, try to define what 'no' means, or what an 'opposite' is. Or simply try whether you are able to reduce the list.

Challenge 540

We can summarize all these results of linguistics by saying that by constructing a statement made only of subject, verb and object, consisting only of nouns and verbs, using only concepts built from the semantic primitives, one is sure that it can be translated into all languages. This explains why science texts often are so boring: the authors are often too afraid to depart from this basic scheme!

Every word was once a poem.
Ralph Waldo Emerson *

Are there semantic primitives in physics?

Is there a basic set of other concepts on which all physics concepts are based? In classical physics, the concepts of space-time, mass and charge form such a set. Two questions arise straight away. Is the set complete? Can it be reduced to a smaller amount of concepts? Both questions will stay with us for a large part of the mountain ascent. Since the answer to the first is negative, we need to be prepared for a longer mountain ascent, in order to find the complete set. This will happen in the middle section. Then the question of the smallest possible set will arise, and keep us busy in the third part.

What is a concept?

Alles, was wir sehen, könnte auch anders sein.
Alles, was wir überhaupt beschreiben können, könnte auch anders sein.
Es gibt keine Ordnung der Dinge a priori. **
Ludwig Wittgenstein, *Tractatus*, 5.634

There is a group of people which has taken the strict view on translation and on precision to the extreme. They build all concepts from an even smaller set of primitives, namely only two: 'set' and 'relation', and explore the various possible combinations of these two concepts, studying their classifications. Step by step, this group of radicals, commonly called *mathematicians*, arrived to define with full precision concepts such as numbers, points, curves, equations, symmetry groups etc. The construction of these concepts is summarized partly in this chapter and partly in Appendix D.

However, despite their precision, in fact precisely because of it, no mathematical concept talks about nature or about observations.*** Therefore the study of motion needs other,

* Ralph Waldo Emerson (1803–1882), US-American essayist and philosopher.

** Whatever we see could be other than it is. Whatever we can describe at all could be other than it is. There is no a priori order of things.

*** Insofar as one can say that mathematics is based on the concepts of 'set' and 'relation', which are based on experience, one can say that mathematics explores a section of reality, and that its concepts are *derived* from

more useful concepts. What properties must a useful concept have? An example: What is ‘freedom’ or what is a ‘parachute’? Obviously, a useful concept implies a list of its parts, its aspects and their internal relations, as well of their relation to the exterior world. Thinkers in various fields, from philosophy to politics, agree that the definition of any *concept* requires:

- explicit and fixed content,
- explicit and fixed limits,
- explicit and fixed domain of application.

The inability to state these properties or keep them fixed is often the easiest way to distinguish *crackpots* from more reliable thinkers. Unclearly defined terms, which thus do not qualify as concepts, regularly appear in myths, e.g. ‘dragon’ or ‘sphinx’, or in ideologies, e.g. ‘worker’ or ‘soul’. Even physics is not immune. For example, we will discover later that neither ‘universe’ nor ‘creation’ are concepts. Are you able to argue the case?

Challenge 557

But the three defining properties of any concepts are interesting in their own right. Explicit content means that concepts are built onto each other. In particular, the most fundamental concepts should be those which have no parts and no internal relations, but only external ones. Can you think of one? Only in the last part of this walk we will discover the final words on the topic.

Challenge 574

Explicit limits, together with the explicit contents, also imply that all concepts describing nature are *sets*, since sets obey the same requirement. In addition, explicit domains of applications imply that all concepts also are *relations*.^{*} Since math is based on the concepts of ‘set’ and of ‘relation’, one follows directly that mathematics can provide the *form* for any concept, especially whenever high precision is required, as in the study of motion. Obviously, the *content* of the description is only provided by the study itself; only then concepts become useful.

In the case of physics, the search for sufficiently precise concepts can be seen as the single theme structuring the long history of the field. Regularly, new concepts were proposed, explored in all their properties, tested, and finally rejected or adopted, in the same way that children reject or adopt a new toy. Children do this unconsciously, scientists do it consciously, using language.^{**} That is why such concepts are universally intelligible.

Note that concept ‘*concept*’ itself is not definable independently of experience; a concept is something that helps us act and react to the world we live in. Moreover, concepts do not live in a separate world from the physical one: every concept requires memory from its user, since the user has to remember the way it was formed; therefore every concept needs

experience. This and similar views of mathematics are called platonism. More concretely, platonism is the view that the concepts of mathematics exist *independently* of people, and that they are discovered, and not created by mathematicians.

In short, since mathematics makes use of the brain, which is a physical system, actually *mathematics is applied physics*.

* One sees that every physical concept, is an example of a (mathematical) *category*, i.e. a combination of objects and mappings. For more details about categories, with a precise definition of the term, see page 433.

** Concepts formed unconsciously in our early youth are the most difficult to define precisely, i.e. with language. Some people who were unable to do so, like the Prussian philosopher Immanuel Kant (1724–1804) used to call them ‘*a priori*’ concepts (such as ‘space’ and ‘time’) to contrast them with the more clearly defined ‘*a posteriori*’ concepts. Today, this distinction has been found to be unfounded both by the study of child psychology (see the footnote on page 418) and by physics itself, so that these qualifiers are thus not used in our walk.

a material support for its use and application. Insofar all thinking and thus every science is fundamentally based on experience.

In conclusion, all concepts are based on the idea that nature is made of related parts. The complementing couples that follow from this idea, such as ‘noun – verb’ in linguistics, ‘set – relation’ and ‘definition – theorem’ in mathematics, and ‘aspect of nature – pattern of nature’ in physics, always guide human thinking, even during childhood, as developmental psychology can testify.

Concepts are merely the results, rendered permanent
by language, of a previous process of comparison.
William Hamilton

What are sets? What are relations?

Defining sets and defining relations are fundamental actions of our thinking. This can be seen most clearly in any book about mathematics; such a book is usually divided in paragraphs labelled ‘definition’ and others labelled ‘theorem’, ‘lemma’ or ‘corollary’. The first type of paragraph defines concepts, i.e. defines sets, and the other three types of paragraphs express relations, i.e. connections between these sets. *Mathematics* is thus the exploration of the possible symbolic concepts and their relations – it is the science of symbolic necessities.

Sets and relations are tools of classification; that is why they are also the tools of any bureaucrat. This class of human beings is characterized by heavy use of paper clips, files, metal closets, archives – which all define various types of sets – and by the extensive use of numbers, such as letter reference numbers, customer numbers, passport numbers, account numbers, law article numbers – which define various types of relations between the items, i.e. between the elements of the sets.



Figure 175 Devices for the definition of sets (left) and of relations (right)

Both the concepts of set and of relation express, in different ways, the fact that nature can be *described*, i.e. that it can be classified into parts which form a whole. The act of grouping together aspects of experience, i.e. the act of classifying them, is expressed in formal language by saying that a set is defined. In other words, a *set* is a collection of *elements* of our thinking. Every set distinguishes the

elements from each other, and from the set itself.

This definition of ‘set’ is called the *naive* definition. For physics, the definition is sufficient, but you won’t find anybody admitting this. In fact, mathematicians have refined the definition of the concept ‘set’ several times, because it does not work well for infinite sets. A famous example is the story about sets which do not contain themselves. Any set is of two sorts: either it contains itself or it does not. If we take the set of all sets who do *not* contain themselves, to which sort does it belong?

To avoid this and similar problems, mathematics needs a precise definition of the concept of ‘set’. The first such definition was given by the German mathematician Ernst Zermelo (1871, Berlin–1951, Freiburg i.B.) and the German-israeli mathematician Adolf/Abraham Fraenkel (1891, München–1965, Jerusalem); later on, the so-called *axiom of choice* was

Challenge 591

The axioms of ZFC set theory

- Two sets are equal if and only if they have the same elements. (Axiom of extensionality)
- The empty set is a set. (Axiom of the null set)
- If x and y are sets, then the unordered pair $\{x, y\}$ is a set. (Axiom of unordered pairs)
- If x is a set of sets, the union of all its members is a set. (Union or sum set axiom)
- The entity $\{0, \{0\}, \{\{0\}\}, \{\{\{0\}\}\}, \dots\}$ is a set – in other words, infinite collections such as the natural numbers are sets. (Axiom of infinity)
- An entity defined by all elements having a given property is a set, provided this property is reasonable – some important technicalities defining ‘reasonable’ being necessary. (Axiom of replacement)
- The entity y of all subsets of x is also a set, called the power set. (Axiom of the power set)
- A set is not an element of itself – plus some technicalities. (Axiom of regularity)
- Picking elements from a list of sets allows to construct a new set – plus technicalities. (Axiom of choice)

Table 40 The defining properties of a set

added, in order to make possible to manipulate a wider class of infinite sets. The result of these efforts is called the ZFC definition.* From this basic definition one can construct all mathematical concepts used in physics. From a practical point of view, it is sufficient to keep in mind that for the whole of physics, the ‘naive’ definition of a set given above is equivalent to the precise ZFC definition, actually even to the simpler ZF definition. Subtleties appear only for some special types of infinite sets, but these are not used in physics. In short, from the basic, naive set definition one can construct all concepts used in physics.

Ref. 20
Challenge 625 But the naive set definition is far from boring. To make two people happy when dividing a cake, one follows the rule: I cut, you choose. What rule is needed for three people? And for four?

Apart from defining sets, every child and every brain creates links between the different aspects of experience. For example, when it hears a voice, it automatically makes the connection that a human is present. Connections of this type are called *relations* in formal language. Relations connect and differentiate elements along other lines than sets: the two form a complementing couple. Defining a set unifies many objects and at the same time divides them into two: those belonging to the set and those which do not; defining a (binary) relation unifies elements two by two and divides them into many, namely into the many couples it defines.

Sets and relations are closely interrelated concepts. Indeed one can define (mathematical) relations with the help of sets. A (*binary*) *relation* between two sets X and Y is a subset of the product set, where the *product set* or *Cartesian product* $X \times Y$ is the set of all ordered pairs

* A global overview of axiomatic set theory is given by PAUL J. COHEN, REUBEN HERSCH, *Non-cantorian set theory*, Scientific American **217**, pp. 104–116, 1967. Those were the times in which Scientific American was a quality magazine.

Ref. 19
See page 432
Challenge 608 Other types of entities, more general than standard sets, obeying other properties, can also be defined, and are also subject of (comparatively little) mathematical research. For an example, see the section on cardinals later on. Such more general entities are called classes whenever they contain at least one set. Can you give an example? In the third part of our mountain ascent we will meet physical concepts which are not described by sets nor by classes, containing no set at all. That is where the real fun starts.

(x, y) with $x \in X$ and $y \in Y$. An *ordered pair* (x, y) can be defined with sets. Can you find out how? For example, in the case of the relation ‘is wife of’, the set X is the set of all women and the set Y that of all men; the relation is given by the list all the appropriate ordered pairs, which is much smaller than the product set, i.e. the set of all possible woman-man combinations.

Challenge 642

It should be noted that the definition of relation just given is not really complete, since every construction of the concept ‘set’ already contains certain relations, such as the relation ‘is element of.’ It does not seem to be possible to reduce either of the concepts ‘set’ or ‘relation’ completely to the other one. This situation is reflected in the physical cases of sets and relations, such as space (as a set of points) and distance, which also seem impossible to separate completely from each other.

Infinity

Mathematicians soon discovered that the concept of ‘set’ is only useful if one can call also collections such as $\{0, 1, 2, 3, \dots\}$, i.e. of the number 0 and all its successors, a ‘set’. To achieve this, one property in the Zermelo-Fraenkel list defining the term ‘set’ explicitly specifies that this collection can be called a set. (In fact, also the axiom of replacement states that sets may be infinite.) Infinity is thus put into mathematics and into the tools of our thought right at the very beginning, in the definition of the term ‘set’. When describing nature, with or without mathematics, one should never forget this fact. In addition, a few other points about infinity should be general knowledge of any expert on motion.

Only *sets* can be infinite. And sets have parts, namely their elements. When a thing or a concept is called ‘infinite’ one can *always* ask and specify what its parts are; for space the parts are the points, for time the instants, for the set of integers the integers, etc. An indivisible or an only finitely divisible entity cannot be called infinite.*

A set is infinite if there is a function from it into itself that is *injective* (i.e. different elements map to different results) but not *onto* (i.e. some elements do not appear as images of the map); e.g. the map $n \mapsto 2n$ shows that the set of integers is infinite. Infinity can be checked also in another way: a set is infinite if it remains so also after removing one element. Even repeatedly. Of course one needs to remember that the empty set is *finite*.

There are *many types* of infinities, all of different size.** This important result was discovered by the Danish-Russian-German mathematician Georg Cantor (1845–1918). He showed that from the countable set of natural numbers one can construct other infinite sets which are not countable. He did this by showing that the *power set* $P(\omega)$, namely the set of all subsets, of a countably infinite set is infinite, but *not* countably infinite. Sloppily speaking, the power set is ‘more infinite’ than the original set. The real numbers \mathbf{R} , to be defined shortly, are an example of an uncountably infinite set; there are many more of them than there are natural numbers. However, *any* type of infinite set contains at least one subset which is countably infinite.

* Therefore, most gods, being concepts and thus sets, are either finite, or, in case they are infinite, they are divisible.

** In fact, there such a huge number of types of infinities, that none of these infinities itself actually describes this number. Technically speaking, there are as many infinities as there are ordinals.

Even for an infinite set one can define size as the number of its elements. Cantor called this the *cardinality* of a set. The cardinality of a finite set is simply given by the number of its elements. The cardinality of a power set is 2 exponentiated by the cardinality of the set. The cardinality of the set of integers is called \aleph_0 , pronounced ‘aleph zero’, after the first letter of the Hebrew alphabet. The smallest *uncountable* cardinal is called \aleph_1 . The next cardinal is called \aleph_2 etc. A whole branch of mathematics is concerned with the manipulation of these infinite ‘numbers’; addition, multiplication, exponentiation are easily defined. For some of them, even logarithms and other functions make sense.*

See page 806

The cardinals defined in this way, including \aleph_n , \aleph_ω , \aleph_{\aleph_n} are called accessible, because in the mean time, people have defined even larger types of infinities, called *inaccessible*. These numbers (inaccessible cardinals, measurable cardinals, supercompact cardinals, etc.) need additional set axioms, extending the ZFC system.

The real numbers have the cardinality of the powerset of the integers, namely 2^{\aleph_0} . Can you show this? One thus has the famous question: Is $\aleph_1 = 2^{\aleph_0}$ or not? The statement that this be so is called the *continuum hypothesis* and was unanswered for several generations. Only in 1963 came the surprising answer: the definition of the concept of set is not specific enough to fix the answer. By specifying the concept of set in more detail, with additional axioms – remember that axioms are defining properties – one can make the continuum hypothesis come out either right or wrong, as one prefers.

Challenge 659

Another result of research into transfinite numbers is important: for every definition of a type of infinite cardinal, it seems to be possible to find a larger one. In everyday life, the idea of infinity is often used to stop discussions about size: ‘My big brother is stronger than yours.’ ‘But mine is infinitely stronger than yours!’ Mathematics has shown that questions on size continue also afterwards: ‘The strength of my brother is the powerset of that of yours!’ Rucker reports that mathematicians think there is no possible nor any conceivable end to these discussions. A simple question appears directly.

Ref. 21

Do infinite quantities exist in nature? Or better, is it necessary to use infinite quantities to describe nature? You might want to specify your own opinion on the issue. It will be settled during the rest of our adventure.

Challenge 676

Functions and structures

Which relations are useful to describe patterns in nature? A typical example is ‘larger stones are heavier’. Such a relation is of a specific type: it relates one specific value of an observable ‘volume’ to one specific value of the observable ‘weight’. Such a one-to-one relation is called a (*mathematical*) *function* or *mapping*. Functions are the most specific types of relations; thus they convey a maximum of information. In the same way as the use of numbers for observables, functions allow easy and precise communication of relations between observations. All physical rules and ‘laws’ are therefore expressed with help of functions, and since physical ‘laws’ are about measurements, functions of numbers are their main building blocks.

A *function* f , or *mapping*, is a thus binary relation, i.e. a set $\{(x, y)\}$ of ordered pairs, where for every value of the first element x , called the *argument*, there is only *one* pair

* Many results are summarized in the excellent and delightful paperback by RUDY RUCKER, *Infinity and the mind – the science and philosophy of the infinite*, Bantam, Toronto, 1983.

(x, y) . The second element y is called the *value* of the function at the argument x . The set X of all arguments x is called the *domain of definition* and the set Y of all second arguments y is called the *range* of the function. One writes

$$f : X \rightarrow Y \quad \text{and} \quad f : x \mapsto y \quad \text{or} \quad y = f(x) \quad (385)$$

where the type of arrow shows whether one is speaking about sets or about elements.

We note that it is also possible to use the couple ‘set’ and ‘mapping’ to define all mathematical concepts; in this case a relation is defined with help of mappings. A modern school of mathematical thought formalized this approach by the use of (mathematical) *categories*, a concept which includes both sets and mappings on an equal footing in its definition. *

To think and talk more clearly about nature, one needs to define more specialized concepts than sets, relations, and functions, because these basic terms are too general. The most important concepts derived from them are operations, algebraic structures, and numbers.

An *binary operation* is a function that maps the Cartesian product of two copies of a set X into itself. In other words, an operation w takes an ordered couple of arguments $x \in X$ and assigns to it a value $y \in X$:

$$w : X \times X \rightarrow X \quad \text{and} \quad w : (x, x) \mapsto y \quad . \quad (386)$$

Is division of numbers an operation following this definition? An *algebraic structure*, also called an *algebraic system*, is (in the most restricted sense) a set together with certain operations. The most important algebraic structures appearing in physics are groups, vector spaces, and algebras.

Challenge 693

In addition to algebraic structures, mathematics is based on *order structures* and on *topological structures*. Order structures are building blocks of numbers and necessary to define comparisons of any sort. Topological structures are built, via subsets, on the concept of neighbourhood. They are necessary to define continuity, limits, dimensionality, topological spaces, and manifolds.

Obviously, most mathematical structures are combinations of various examples of these three basic structure types. For example, the system of real numbers is given by the set of real numbers with the operations of addition and multiplication, the order relation ‘is larger than’, and a continuity property. They are thus built by combining an algebraic structure, an order structure and a topological structure.

Ref. 22

The mathematical systems of importance in physics are presented partly in the following and partly in Appendix D.

Numbers

Which numbers are multiplied by six when their last digit is taken away and transferred to the front?

Challenge 710

Numbers are the oldest mathematical concept and are found in all cultures. The notion of number, in Greek $\alpha\rho\iota\theta\mu\omicron\varsigma$, has often been changed with the aim to include more and more general objects, but always retaining the general idea that numbers are entities which can be added, subtracted, multiplied and divided.

The modern way to write numbers, as e.g. in $12345679 \cdot 45 = 666666666$, is essential for science.* It can be argued that the lack of a good system for writing down and for calculating with numbers has kept the progress of science back for several centuries. (By the way, the same can be said for the affordable mass reproduction of written texts.)

Challenge 727

The simplest numbers, $1, 2, 3, 4, \dots$, are usually seen as being taken directly from experience. However, they can also be constructed from the notions of ‘relation’ and ‘set’. One of the many possible ways to do this (can you find one?) is by identifying a natural number with the set of its predecessors. With the relation S , ‘successor of’, this definition can be written as

$$\begin{aligned} 0 &:= \emptyset, & 1 &:= S0 = \{0\}\{\emptyset\}, \\ 2 &:= S1 = \{0, 1\} = \{\emptyset, \{0\}\} & \text{and} & \quad n+1 := Sn = \{0, \dots, n\} \end{aligned} \quad (387)$$

This set, together with the binary operations ‘addition’ and ‘multiplication,’ constitutes the algebraic system $N = (N, +, \cdot, 1)$ of the *natural numbers*.** (Sometimes the number zero is

* A *category* is defined as a collection of objects and a collection of ‘morphisms’ or mappings. Morphisms are composable, the composition is associative, and there is an identity morphism. The strange world of category theory, sometimes called the abstraction of all abstractions, is presented in ...

Note that every category contains a set; since it is unclear whether nature contains sets, as we will discuss on page 460, it is questionable whether categories will be useful in the unification of physics, despite their abstract charm.

* However, there is no need for written numbers for doing mathematics, as shown by MARCIA ASCHER, *Ethnomathematics – a multicultural view of mathematical ideas*, Brooks/Cole, 1991.

** Any system with the same properties as the natural numbers is called a *semi-ring*. A *ring* $(R, +, \cdot)$ is a set R of elements with two binary operations, called *addition* and *multiplication*, usually written $+$ and \cdot (or simply dropped), for which the following properties hold for all elements $a, b, c \in R$:

- R is a commutative group with respect to addition, i.e. one has $a + b \in R$, $a + b = b + a$, $a + 0 = a$, $a + (-a) = a - a = 0$ as well as $a + (b + c) = (a + b) + c$
- R is closed under multiplication, i.e. $ab \in R$
- multiplication is associative, i.e. $a(bc) = (ab)c$
- distributivity holds, i.e. $a(b + c) = ab + ac$ and $(b + c)a = ba + ca$.

Defining properties such as these are also called *axioms*. Note that axioms are not basic beliefs, as often, but wrongly stated; axioms are the basic properties used in the definitions of a concept, in this case, that of ring. A *semi-ring* is a set with all the properties of a ring, except that the existence of neutral and negative elements for addition is replaced by the weaker requirement that if $a + c = b + c$ then $a = b$. A *field* K is a ring with

- an identity 1 , such that for all elements a one has $1a = a$,
- at least one element different from zero, and most importantly
- a (multiplicative) inverse a^{-1} for every element $a \neq 0$.

A ring or field are said to be *commutative* if the multiplication is commutative. A non-commutative field is also called a *skew field*. Fields can be finite or infinite. All finite fields are commutative. In a field, all equations of the type $cx = b$ and $xc = b$ ($c \neq 0$) have solutions for x ; they are unique if $b \neq 0$. To sum up sloppily by focusing

not counted as a natural number.) For all number systems the algebraic system and the set are often sloppily designated by the same symbol.

Table 41 Some large numbers

Number	examples in nature
Around us	
1	number of angels which can be in one place, following Thomas Aquinas Ref. 23
20	number of digits in precision measurements which will probably never be achieved
34, 55, 89	petals of common types of daisy and sunflower Ref. 24
57	faces of a diamond with brilliant cut
2000	stars visible in the night sky
10^5	leaves of a tree (10 m beech)
6 to $7 \cdot 10^9$	humans in the year 2000
10^{17}	ants in the world
ca. 10^{20}	number of snowflakes falling on the earth per year
ca. 10^{23}	grains of sand in the Sahara desert
10^{22}	stars in the universe
10^{25}	cells on earth
$1.1 \cdot 10^{50}$	atoms making up the earth ($6370^3 \text{ km}^3 \cdot 4 \cdot 3.14/3 \cdot 5500 \text{ kg/m}^3 \cdot 30 \text{ mol/kg} \cdot 6 \cdot 10^{23} / \text{mol}$)
10^{81}	atoms in the visible universe
10^{90}	photons in the visible universe
10^{169}	number of atoms fitting in the visible universe
10^{244}	number of space-time points inside the visible universe
Information	
51	record number of languages spoken by one person
ca. 5000	words spoken on an average day by a man
ca. 7000	words spoken on an average day by a woman
ca. 350 000	words of the English language (more than any other language, with the possible exception of German)
ca. 2 000 000	number of scientists on earth around the year 2000
$3 \cdot 10^8$	words spoken during a lifetime (2/3 time awake, 30 words per minute)
$4 \cdot 10^9$	pulses exchanged between both brain halves every second
10^9	words heard and read during a lifetime (2/3 time awake, 30 words per minute)
10^{17}	image pixels seen in a lifetime ($3 \cdot 10^9 \text{ s} \cdot (1/15 \text{ ms}) \cdot 2/3 \text{ (awake)} \cdot 10^6 \text{ (nerves to the brain)}$) Ref. 25
10^{19}	bits of information processed in a lifetime (the above times 32)
ca. $5 \cdot 10^{12}$	printed words available in (different) books around the world (ca. $100 \cdot 10^6$ books consisting of 50 000 words)
$2^{10} \cdot 3^7 \cdot 8! \cdot 12!$	= possible positions of the $3 \times 3 \times 3$ Rubik's cube Ref. 26
$4.3 \cdot 10^{19}$	
$5.8 \cdot 10^{78}$	possible positions of the $4 \times 4 \times 4$ Rubik-like cube
$5.6 \cdot 10^{117}$	possible positions of the $5 \times 5 \times 5$ Rubik-like cube

on the most important property, a field is a set of elements for which, together with addition, subtraction and multiplication, a *division* is also defined.

Number	examples in nature
ca. 10^{200}	possible games of chess
ca. 10^{800}	possible games of go
ca. 10^{10^7}	possible states in a personal computer
Parts of us	
$150\,000 \pm 50\,000$	hairs on a healthy head
900 000	neurons in the brain of a grasshopper
$127 \cdot 10^6$	light sensitive cells per retina
10^{10} to 10^{11}	neurons in the human brain
$> 10^{16}$	memory bits in the human brain
600	numbers of muscles in the human body, of which about half are in the face
10^{13} to 10^{14}	cells in the human body
10^{14}	bacteria carried in the human body
$500 \cdot 10^6$	blinks of the eye during a lifetime (about once every four seconds when awake)
$300 \cdot 10^6$	breaths taken during human life
$3 \cdot 10^9$	heart beats during a human life
$3 \cdot 10^9$	letters (base pairs) in haploid human DNA
$6.1 \cdot 10^9$	bits in a compact disk

The system of *integers* $Z = (\dots, -2, -1, 0, 1, 2, \dots, +, \cdot, 0, 1)$ is the minimal ring which is an extension of the natural numbers. The system of *rational numbers* $Q = (Q, +, \cdot, 0, 1)$ is the minimal field which is an extension of the ring of the integers. The system of the *real numbers* $R = (R, +, \cdot, 0, 1, >)$ is the minimal extension of the rationals which is continuous and totally ordered. (For the definition of continuity, see page 856.) Equivalently, it is the minimal extension of the rationals which is a complete, totally strictly-archimedean ordered field. But the construction, i.e. the definition, of integer, rational and real numbers from the natural numbers is not only possible in the way just mentioned. Perhaps the most beautiful definition of all these types of numbers is the one discovered in 1969 by John Conway, and popularized by him, Donald Knuth, and Martin Kruskal.

Ref. 27

- A number is a sequence of bits. They are usually called ups and downs, and examples are shown in Figure 176.
- The empty sequence is zero.
- A finite sequence of n ups is the integer number n , and a finite sequence of n downs is the integer $-n$. Finite sequences of mixed ups and downs give the *dyadic rational numbers* are the numbers made of a finite sequence of ups and downs. Examples are 1, 2, 3, -7, 19/4, 37/256 etc. They all have denominators with a power of 2. The other *rational numbers* are those which end in an infinitely repeating string of ups and downs, such as 2/3. Simply countably infinite series give the *reals*, the *infinitesimals*, and simple infinite numbers. Longer countably infinite series give even more crazy numbers. The complete class is called the *surreal numbers*.*

* The surreal numbers do *not* form a set because they contain all *ordinal numbers*, which themselves do not form a set, even though they of course *contain* sets. In short, ordinals and surreals are classes which are larger than sets.

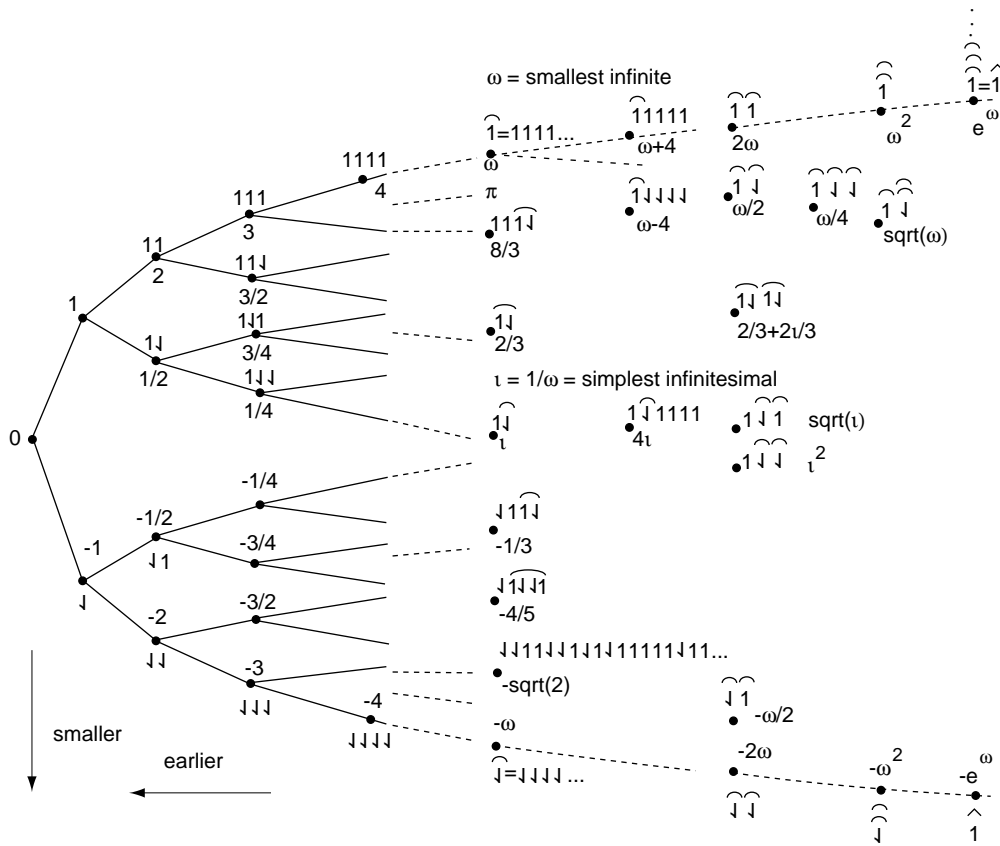

Figure 176 The surreal numbers in conventional and in bit notation

There are two ways to write surreal numbers. The first is the just mentioned sequence of bits. But to define addition and multiplication, one usually uses another notation, deduced from Figure 176. A surreal s is defined as the earliest number of all those between two series of earlier surreals, the left and the right series:

$$\alpha = \{a, b, c, \dots | A, B, C, \dots\} \quad \text{with} \quad a, b, c, < \alpha < A, B, C \quad (388)$$

For example, one has

$$\{0|\} = 1 \quad , \quad \{0, 1|\} = 2 \quad , \quad \{|0\} = -1 \quad , \quad \{|-1, 0\} = -2 \quad , \quad \{0|1\} = 1/2 \quad , \\ \{0|1/2, 1/4\} = 1 \quad , \quad \{0, 1, 3/2, 25/16 | 41/16, 13/8, 7/4, 2\} = 1 + 37/64$$

showing that the finite surreals are the *dyadic numbers* $m/2^n$. Given two surreals $\alpha = \{\dots, a, \dots | \dots, A, \dots\}$ with $a < \alpha < A$ and $\beta = \{\dots, b, \dots | \dots, B, \dots\}$ with $b < \beta < B$, addition is defined recursively, using earlier, already defined numbers, as

$$\alpha + \beta = \{\dots, a + \beta, \dots, \alpha + b, \dots | \dots, A + \beta, \dots, \alpha + B, \dots\} \quad . \quad (389)$$

This definition is used for the simple reason that it gives the same results as usual addition for integers and reals. Can you confirm this? By the way, addition is not always commutative. Are you able to find the exceptions, and to find the definition for subtraction? Challenge 744

Multiplication is also defined recursively, by the expression

$$\alpha\beta = \{ \dots, a\beta + \alpha b - ab, \dots, A\beta + \alpha B - AB, \dots | \dots, a\beta + \alpha B - aB, \dots, A\beta + \alpha b - Ab, \dots \} \quad (390)$$

These definitions allow to write $\iota = 1/\omega$, and to talk about numbers such as $\sqrt{\omega}$, the square root of infinity, about $\omega + 4$, $\omega - 1$, 2ω , e^ω and about other strange numbers shown in Figure 176. However, the surreal numbers are not commonly used. More common is one of their subsets.

The *real numbers* are all those surreals whose length is not larger than infinity and who do not have periodic endings with a period of length 1. In other words, the surreals distinguish the number 0.9999999 from the number 1, whereas the reals do not. In fact, between the two, there are infinitely many surreal numbers. Can you name a few?

Challenge 761

Reals are more useful to describe nature than surreals, because first of all they form a set, which the surreals do not, and secondly because they allow the definition of integration. Other numbers defined with the help of reals, e.g. the complex numbers C and the quaternions H , are also presented in Appendix D. A few more elaborate number systems are also presented there.

See Appendix D

To conclude, in physics it is usual to call *numbers* the elements of any set which is a semi-ring (e.g. N), a ring (e.g. Z) or a field (Q, R, C, H). Since numbers allow to compare magnitudes, all play important roles in the description of observations.

Ref. 28

When a series of equal balls is packed in such a way that the area of necessary wrapping paper is minimal, for a small number of balls the linear package, with all balls in one row, is the most efficient. For which number of balls is the linear package not a minimum any more?

Challenge 778

Why use maths?

Die Forderung der Möglichkeit der einfachen Zeichen ist die Forderung der Bestimmtheit des Sinnes.*
Ludwig Wittgenstein, *Tractatus*, 3.23

Several well-known physicists have asked this question repeatedly. For example, Niels Bohr is quoted to have said: ‘We do not know why the language of mathematics has been so effective in formulating those laws in their most succinct form.’ Eugene Wigner wrote an often cited paper entitled *The unreasonable effectiveness of mathematics*. At the start of science, many centuries earlier, Pythagoras and his contemporaries were so overwhelmed by the usefulness of numbers in describing nature, that Pythagoras was able to organize a sect based on this connection. The members of the inner circle of this sect were called ‘learned people,’ in Greek ‘*mathematicians*,’ from the Greek $\mu\acute{\alpha}\theta\eta\mu\alpha$ ‘teaching’. This sect title then became the name of the profession.

Ref. 29

Ref. 30

All these men forgot that numbers, as well as a large part of math, are concepts developed precisely with the aim to describe nature. And most of all, these concepts were developed

* The requirement that simple signs be possible is the requirement that sense be determinate.

right from the start to provide a description as succinct as possible. That is one aspect of the fact that mathematics is the science of symbolic necessities.

But perhaps this answer is too dismissive. Perhaps these thinkers mainly wanted to express their feeling of wonder when experiencing that language works, that thinking and our brain works, and that life and nature are so beautiful. This would put the title question nearer to the well-known statement by Albert Einstein: ‘The most incomprehensible fact about the universe is that it is comprehensible.’ Comprehension is another word for description, i.e. for classification. Obviously, any separable system is comprehensible, and there is nothing strange about it. But is the universe separable? As long as it is described as being made of particles and vacuum, this is the case. But whether this actually is correct will be revealed only in the third part of this walk.

Die Physik ist für Physiker viel zu schwer.*
David Hilbert (1862–1943), mathematician.

Is mathematics a language?

Die Sätze der Mathematik sind Gleichungen, also Scheinsätze.
Der Satz der Mathematik drückt keinen Gedanken aus.**
Ludwig Wittgenstein, *Tractatus*, 6.2, 6.21

Surely, mathematics is a *vocabulary* which helps to talk with precision. Mathematics can be seen as the exploration of *all* possible concepts which can be constructed from the two fundamental bricks ‘set’ and ‘relation’ (or some alternative pair). Therefore, *mathematics* is the science of symbolic necessities. Rephrased again, mathematics is the exploration of all possible types of classifications. This explains its usefulness in all situations where complex, yet precise classifications of observations are necessary, such as in physics.

However, mathematics cannot express everything humans want to communicate, e.g. an idea one had or the fun of swimming. Mathematics is the science of symbolic necessities; thus mathematics is not a language, nor does it contain one. The basic reason for this limitation is that mathematical concepts, being based on *abstract* sets and relations, do not pertain to nature. Mathematics does not allow to talk about nature nor about its basic property: the observation of motion and of change.

In his famous 1900 lecture in Paris, the German mathematician David Hilbert*** had given a list of 23 great challenges facing mathematics. The sixth of Hilbert’s problems was to find a mathematical treatment of the axioms of physics. Our adventure so far has shown

* Physics is much too difficult for physicists.

** The propositions of mathematics are equations, and therefore pseudo-propositions. A proposition of mathematics does not express a thought.

*** David Hilbert (1862, Königsberg–1943, Göttingen), professor of mathematics in Göttingen, greatest mathematician of his time. He was central to many parts of mathematics, and also played an important role both in the birth of general relativity and of quantum theory. His textbooks are still in print. His famous motto was: ‘Wir müssen wissen, wir werden wissen.’ The famous Paris lecture is published e.g. in *Die Hilbertschen Probleme*, Akademische Verlagsgesellschaft Geest & Portig, 1983. The lecture galvanized all of mathematics. (Despite efforts and promises of similar fame, *nobody* in the world had a similar overview of mathematics which allowed him or her to repeat the feat in the year 2000.) In his last decade he suffered the persecution of the Nazi regime, which eliminated Göttingen from the list of important science universities up to this day.

that physics started with *circular* definitions which are not yet eliminated after 2500 years of investigations; most important is the definition of space-time with help of objects, and the definition of objects with help of space and time. Physics is thus *not* modelled after mathematics, even if many physicists and mathematicians, including Hilbert, would like it to be so. Physicists have to live with logical problems, and have to walk on unsure ground in order to achieve progress.

See page 111
 See page 716
 If physics were an axiomatic system, it would not contain contradictions, would cease to be a language, and would cease to describe nature. We will settle this topic later on.

In short, mathematics is *not* a language, the main reason being that one cannot use it to express the existence or the observation of motion. However, we can and indeed will use mathematical concepts in the description of nature wherever possible.

Curiosities and fun challenges

- Challenge 795
- What is the largest number which can be written with four digits of 2, and no other sign? And with four 4s?
 - Pythagorean triplets are integers which obey $a^2 + b^2 = c^2$. Give at least ten examples. Show the following three properties: at least one number in a triplet is a multiple of 3. At least one number in a triplet is a multiple of 4. At least one number in a triplet is a multiple of 5.
 - The number $1/n$, when written in decimal notation, has a periodic sequence of digits. The period is at most $n - 1$ digits long, as for $1/7 = 0.142857\ 142857\ 1428\ldots$. Which numbers n have periods $n - 1$?

Physical concepts and patterns of nature

Die Grenzen meiner Sprache bedeuten die Grenzen meiner Welt.*
 Ludwig Wittgenstein, *Tractatus*, 5.6

Der Satz ist ein Bild der Wirklichkeit.
 Der Satz ist ein Modell der Wirklichkeit, so wie wir sie uns denken.**
 Ludwig Wittgenstein, *Tractatus*, 4.01

In contrast to mathematics, physics does aim at being a language. Through the description of motion it aims to express *everything* observed, and in particular, all examples and possibilities of change.*** Like any language, physics consists of concepts and sentences. In

* *The limits of my language* are the limits of my world.

** A proposition is a picture of reality. A proposition is a model of reality as we imagine it.

*** All observations are about change or variation. The various types of change are studied by the various sciences; they are usually grouped in the three categories of *human sciences*, *formal sciences* and *natural sciences*. Among the latter, the oldest are astronomy and metallurgy. Then, with the increase of curiosity in early antiquity, came the natural science concerned with the topic of motion: *physics*. In the course of our walk it will become clear that this seemingly restrictive definition indeed covers the whole set of topics studied in physics. In particular it includes the more common definition of physics as the study of matter, its properties, its components, and their interactions.

order to be able to express everything, it must aim to make few words about a lot of facts.* Physicists are essentially *lazy* people: they try to minimize the effort in everything they are doing. The concepts in use today have been optimized by the combined effort of many people to be as practical, i.e. as powerful as possible. A concept is called *powerful* when it allows to express in a compact way a large amount of information, meaning that it can convey rapidly a large number of details about observations.

General statements about many examples of motion are called *rules* or *patterns*. In the past, one often said ‘laws govern nature’, using an old and inappropriate ideology. A physical ‘law’ is a way to talk about as much as possible with as few words as possible. Indeed, laws essentially are precise descriptions. Why precise? Because of their laziness, people want to say as much as possible in as few words as possible. When saying ‘laws govern nature’ one actually means to say ‘being lazy, we describe observations with patterns.’ Laws are the epitome of laziness. *Making* laws is pure sloth. In fact, the correct expression is *patterns describe nature*.

Physicists have defined the laziness necessary for their field in much detail. In order to become a master of laziness, one needs to distinguish lazy patterns from those which are not, such as lies, beliefs, statements which are not about observations, and statements which are not about motion. We do this shortly.

The principle of extreme laziness is the origin, among others, of the use of numbers in physics. Observables are often best described with the help of numbers, because numbers allow easy and precise communication and classification. Length, velocity, angles, temperature, voltage, field strength, etc. are of this type. The notion of ‘number’, used in every measurement, is constructed, often unconsciously, from the notions of ‘set’ and ‘relation’, as shown above. Apart from the notion of number, other concepts are regularly defined to allow fast and compact communication of the ‘laws’ of nature; all are ‘abbreviation tools.’ In this sense, the statement ‘the level of the Kac-Moody algebra of the Lagrangian of the heterotic superstring model is equal to one’ contains precise information, explainable to everybody but which would take dozens of pages if one would express it only using the terms ‘set’ and ‘relation.’ In short, the *precision* common in physics results from its *quest for laziness*.

Are physical concepts discovered or created?

Das logische Bild der Tatsachen ist der Gedanke.**
Ludwig Wittgenstein, *Tractatus*, 3

The question is often rephrased as: are physical concepts free of beliefs, tastes, or of choices? The question has been discussed so much that in the mean time it even appears in Hollywood movies. A short summary.

* A particular, specific observation, i.e. a specific example of input shared by others, is called a *fact*, or in other contexts, an *event*. A striking and regularly observed fact is called a *phenomenon*, and a general observation made in many different situations is called a (*physical*) *principle*. (Often, when a concept is introduced which is used with other meaning in other fields, in this walk it is preceded by the qualifier ‘physical’ or ‘mathematical’ in between brackets.) Actions performed towards the aim of collecting observations are called *experiments*. The concept of experiment became established in the sixteenth century; in the evolution of a child, it is best compared to that activity which has the same aim of collecting experiences: *play*.

** A logical picture of facts is a thought.

Creation, in contrast to discovery, implies free choice between many alternative possibilities. The chosen alternative would then be due to the beliefs or tastes implied in any created concept. In physics (and in obvious contrast to other, more ideological fields), one knows that different physical descriptions of observations are either equivalent, or, in the opposite case, partly imprecise or even wrong. A description of observations is thus essentially unique: choices are only apparent. There is no freedom in the definition of physical concepts, except for equivalent reformulations, in strong contrast to the case of any creative activity.

If two different concepts could be used to describe the same aspect of observations, they must be equivalent, even if the relation that leads to the equivalence is not clear immediately. (By the way, one knows no physical concept which can be called ‘created’ instead of discovered.) In fact, the requirement that people with different standpoints observing the same event from equivalent descriptions lies at the very basis of physics. It forms the symmetry requirements of nature: examples are the principle of relativity and the principle of gauge invariance. In short, the requirement of viewpoint independence makes the free choice of concepts a logical impossibility.

The conclusion that concepts describing observations are discovered is also reached independently in the field of linguistics by the mentioned research on semantic primitives, * in the field of psychology by the observations on the formation of the concepts in the development of young children, and in the field of ethology by the observations of animal development, especially in the case of mammals. All three fields have observed in detail how the interactions between an individual and its environment lead to concepts, of which in particular the most basic ones, such as space, time, object, interaction etc., are common across the sexes, cultures, races, and across many animal species populating the world. Curiosity and the way nature works leads to the same concepts for all people and even the animals; the world offers only one possibility, without room for imagination. Thinking the opposite is a belief – often a useful exercise, but never successful.

Physical concepts are classifications of observations. The activity of classification itself follows the patterns of nature; it is a mechanical process which also machines can perform. This means that any distinction, i.e. any statement that A is different from B, is a theory free statement. No belief system is necessary to distinguish different entities in nature. Physicists *can* be replaced by machines. The end of our mountain ascent will confirm this point.

As mentioned already, physical concepts are made up in a way to describe observations as succinctly and as accurately as possible. They are formed with the aim to have the largest possible amount of understanding with the smallest possible amount of effort.

In summary, we found that physical concepts are the same for everybody and are free of beliefs: they are first of all *boring*. Moreover, as they could stem from machines instead of people, they are *born of laziness*. Evidently they are *not* discovered. Having handled the case of physical concepts, let us turn to physical statements. The situation is somewhat similar: physical statements must be lazy, arrogant and boring. Let us see why.

Wo der Glaube anfängt, hört die Wissenschaft auf. **

* Anna Wierzbicka concludes that her research clearly indicates that semantic primitives are *discovered*, in particular that they are deduced from the fundamentals of human experience, and not invented.

** Where belief starts, science ends.

Ernst Haeckel, *Natürliche Schöpfungsgeschichte*, 1879.

How do we find physical patterns and rules?

Grau, treuer Freund, ist alle Theorie,
Und grün des Lebens goldner Baum.*
Goethe (1749–1832), *Faust*.

Physics is usually presented as an objective science, but I notice that physics changes
and the world stays the same, so there must be something subjective about physics.

Richard Bandler

Progressing through the study of motion reflects a young child's attitude towards life, which follows the simple program on the left:

Normal description

Curiosity

1. look around a lot
2. don't believe anything told
3. choose something particularly interesting and explore it yourself
4. make up your own mind, and try to describe precisely what you saw
5. check if you can describe also other, similar situations in the same way
6. increase the precision of observation until the checks either fail or are complete
7. depending on the case, continue with step 4 or 1 of a new round.

Lobbyist description

Scientific method

- interact with the world
- forget authority
- observe
- use reason, build hypotheses
- analyse hypothesis
- perform experiments until hypothesis is falsified or established
- ask for more money

Adult scientists do not have much more to add, except the more fashionable terms on the right, plus several specialized professions to make money from them. The experts of step 7 are variously called lobbyists or professors; instead of calling this program 'curiosity', they call it the 'scientific method.' They mostly talk. Physics being the talk about motion,** and motion being a vast topic, many people specialize in this step.

The experts of step 6 are called *experimental physicists* or simply *experimentalists*, a term derived from the Latin 'experiri', meaning 'to try out'. Most of them are part of the category of 'graduate students'. The experts of steps 5 and 4 are called *theoretical physicists* or simply *theoreticians*. This is a rather modern term; for example, the first professors of theoretical physics were appointed only around the start of the twentieth century. The term is

* Grey, dear friend, is all theory, and green the golden tree of life.

** Several sciences have the term 'talk' as part of their name, namely all those whose name finishes in '-logy', such as e.g. biology. The ending stems from ancient Greek and is deduced from ληγγηιν meaning 'to say, to talk'. Physics as science of motion could thus be called 'kinesiology' from κίνησις, meaning 'motion'; but for historical reasons this term has a different meaning, namely the study of human muscular activity. The term 'physics' is either derived from the Greek φύσις (τέχνη is understood) meaning 'the art of nature', or from the title of Aristotle's works τὰ φυσικά meaning 'natural things'. Both expressions are derived from φύσις, meaning 'nature'.

derived from the Greek $\theta\epsilon\omega\rho\acute{\iota}\alpha$ meaning ‘observation, contemplation’. Finally, those people focussed on steps 1 to 3, who get others to work on steps 4 to 6, are called *geniuses*.

But obviously the most important point is hidden in step 6: how do all these people know whether their checks fail? How do they recognize truth? In other words,

All professions are conspiracies against laymen.
George Bernard Shaw

What is a lie?

Get your facts straight, and then you can distort them at you leisure.
Mark Twain (1835–1910)

The pure truth is always a lie.
Bert Hellinger

Lies are useful statements, as everybody learns during youth. One reason they are useful is because one can draw any imaginable conclusion from them. A well-known discussion between two Cambridge professors early in the twentieth century makes the point. McTaggart asked: ‘If $2 + 2 = 5$, how can you prove that I am the pope?’ Hardy: ‘If $2 + 2 = 5$, then $4 = 5$; subtract 3; then $1 = 2$; but McTaggart and the pope are two; therefore McTaggart and the pope are one.’ As already noted a long time ago, *ex falso quodlibet*. From what is wrong, anything imaginable can be deduced. It is true that in our mountain ascent we need to build on previously deduced results and that our trip could not be completed if we had a false statement somewhere in our chain of arguments. But lying is such an important activity that one should learn to perform it properly.

Ref. 4 There are various stages in the art of lying. Animals have been shown to deceive their kin. Children start just before their third birthday, by hiding experiences. Adults cheat on taxes. And some intellectuals may claim that truth does not exist.

However, in most countries, everybody must know what ‘truth’ is, since in court for example, telling the opposite can lead to a prison sentence. And courts are full of experts in lie detection. So if one lies in court, one better does it properly. For a court, a lie is a statement in contrast with observations.* The truth of a statement is thus checked by observation. The check itself is sometimes called the *proof* of the statement. For courts, as for physics, truth is thus the correspondence with facts. And facts are shared observations. A good lie is thus a lie whose contrast with shared observations is hard to discover.

The first way to lie is to put the emphasis on the sharedness only. Populists and polemicists do that regularly. (‘Every foreigner is a danger for the values of our country.’) Since almost any imaginable opinion, however weird, is held by some group, one can always claim it as true. Unfortunately, it is not a secret that ideas get shared also because they are fashionable, or imposed, or opposed to somebody generally disliked, such as some sibling in the family

* Statements not yet checked are variously called *speculations*, *conjectures*, *hypotheses*, or – wrongly – simply *theses*. Statements which are in correspondence with observations are called *correct* or *true*, otherwise *wrong*, *false*, or *lies*.

– remember Cassandra.* For a good lie one thus needs more than sharedness, more than *intersubjectivity*. A good lie should be, like a true statement, really independent of the listener or the observer, and in particular independent of their age, their sex, their education, their civilization, or the group they belong to. For example, it is especially hard – but not impossible – to lie with mathematics. The reason is that the basic concepts of mathematics, be they ‘set’, ‘relation’, or ‘number’ are taken from observation and are intersubjective, so that statements about them are easily checked. Usual lies thus avoid mathematics.

Secondly, a good lie should avoid statements about observations, and use *interpretations* instead. For example, some people like to talk about other universes, which implies talking about one’s imagination, not about observations. One has to avoid however, to fall in the opposite extreme, namely to make statements which are meaningless; the most destructive comment one can make about a statement is the one used by the Austrian physicist Wolfgang Pauli (1900, Wien–1958, Zürich): that is ‘not even wrong’.

Thirdly, a good lie doesn’t care about observations, only about imagination. Only truth needs to be *empirical*, to distinguish it from *speculative* statements. If one wants to lie well even with empirical statements, one needs to distinguish two cases. There are two types of empirical statements: *specific* statements and *universal* statements. For example, ‘On the 31st of August 1960 I saw a green swan swimming on the northern shore of the lake of Varese’ is specific, whereas ‘All ravens are black’ is universal, since it contains the term ‘all’. Universal statements are also called *theories*. There is a well-known difference between the two, which is important for lying well: specific statements cannot be falsified, they are only verifiable, and universal statements cannot be verified, they are only falsifiable.

Ref. 31

Why is this so? Universal statements such as ‘the speed of light is constant’ cannot be tested for *all* possible cases. (Note that if they could, they would not be universal statements, but just a list of specific ones.) However, they can be reversed by a counterexample. Another example of the universal type is: ‘Apples fall upwards’. Since it is falsified by an observation conducted by Newton several centuries ago, or by everyday experience, it qualifies as an (easily detectable) lie. In general therefore, lying by stating the opposite of theories is usually unsuccessful. If somebody insists on doing so, the lie becomes a *superstition*, a *belief*, a *prejudice* or a *doctrine*. Those are the low points in the art of lying. A famous case of insistence on a lie is that of the colleagues of Galileo, who are said to have refused to look through his telescope to be convinced that Jupiter has moons, an observation which would have shaken their statement and belief that everything turns around the earth. Obviously these astronomers were amateurs in the art of lying. A good universal lie is one whose counterexample is not easily spotted.

There should be no insistence on lies in physics. Unfortunately, classical physics is full of them. We try to get rid of the remaining ones during the rest of our walk.

On the other hand, lying with specific statements is much easier. (‘I can’t remember.’) Even a specific statement such as ‘yesterday the moon was green, cubic, and smelled of

* The implications of birth order on creativity in science and on acceptance of new ideas has been studied in the fascinating book by FRANK J. SULLOWAY, *Born to rebel – birth order, family dynamics, and creative lives*, Pantheon Books, 1996. This exceptional book tells the result of a life-long study correlating the personal situation in the family of thousands of people and their openness to about twenty revolutions in the recent history. The book also includes a test in which one can deduce one own propensity to rebel, on a scale from 0 to 100%. Darwin scores 96% on that scale.

cheese' can never be completely falsified: there is no way to show with absolute certainty that this is wrong. The only thing one can do is to check whether the statement is compatible with other observations, such as whether the different shape affected the tides as expected, whether the smell can be found in air collected that day, etc. A good specific lie is thus not in contrast with other observations.*

By the way, universal and specific statements are connected: the *opposite* of a universal statement is always a specific statement, and vice versa. For example, the opposite of the general statement 'apples fall upwards' namely 'some apples fall downwards' is specific.

In other words, courts and philosophers disagree. Courts have no issue with calling theories true, and specific statements lies. Many philosophers avoid this. For example, the statement 'Ill-tempered gaseous vertebrates do not exist' is a statement of the universal type. If a universal statement is in agreement with observations, and if it is falsifiable, courts call it *true*. The opposite, namely the statement: 'ill-tempered gaseous vertebrates do exist' is of the *specific* type, since it means 'Person X has observed a ill-tempered gaseous vertebrate in some place Y at some time Z.' To verify it, one needs a record of the event. If such records, for example by photographs, witnesses, etc., do not exist, and if the statement *can* be falsified by other observations, courts call the specific statement a *lie*. Even though these are the rules for everyday life and for the law, there is no agreement between philosophers and scientists that this is acceptable. Intellectuals are extremely careful, mainly because many of them have lost their life by exposing various lies too openly.

In short, specific lies, like all specific statements, can never be falsified with certainty. That makes them so popular. Children learn them first. ('I haven't eaten the jam.') General lies, like all general statements, can always be corroborated by examples. That is the reason for the success of ideologies. But the criteria for recognizing lies have become so commonplace that beliefs and lies try all to keep up. It became fashionable to use expressions such as 'scientific fact' – there are no non-scientific facts –, or 'scientifically proven' – observations cannot be proven otherwise – and similar empty phrases. These are not really good lies, since whenever one encounters sentences starting with 'science says ...' or 'science and religion do ...', replacing 'science' by 'knowledge' or 'experience' is an efficient way to check whether such statements are to be taken seriously or not.**

An important aspect makes lies more attractive than true statements, be they universal or specific. True statements require the author to stick his neck out to criticism. If one doesn't stick the neck out, it can't be a lie, nor a observation, nor a theory. Lying does make one

* It is often difficult or tedious to verify statements from the past, and the difficulty increases with the distance in time. That is why people can insist on the occurrence of events which are supposed to be exceptions to the patterns of nature ('miracles'). Since the advent of rapid means of communication these checks are becoming more and more easy, and there do not seem to be many miracles left. This happened in the miracle place Lourdes in France, where even though the number of visitors is much higher than in the past, no miracles have been seen in decades.

In fact, most modern miracles are kept alive only by consciously eschewing checks, such as the supposed yearly liquefaction of blood in Napoli, the milk supposedly drunk by statues, the supposed healers in television evangelism, etc. Nevertheless, many organizations make money from the difficulty to falsify specific statements. When the British princess Diana died in a car crash in 1997, even though the events were investigated in extreme detail, the scandal press could go on almost without end about the 'mysteries' of the accident.

** Just to clarify the vocabulary usage of this text, *religion* is spirituality plus a varying degree of power abuse. The mixture depends on each person's history, background, and environment. *Spirituality* is the open participation in the whole of nature. Most people with a passion for physics are spiritual.

vulnerable. For this reason, theories are often *arrogant, provoking* and at the same time they have to be *vulnerable*. Theories thus resemble a beautiful woman: fragile and haughty at the same time. * On the other hand, specific statements about observations must be boring and rock-solid. They are opposite in character to theories. Reading books which developed daring theories, such as Darwin's *The origin of the species*, one easily feels the stark contrast between the numerous boring and solid facts and the arrogant and vulnerable theory that he deduced.

But public check is not always reliable. For example, collective imagination played a large role when scientists were talking about 'aether', 'UFOs', 'creation science', and 'cold fusion'. Nevertheless, an important aspect of any lie is to make as little *public* statements as possible, so that others can check as little as possible. (For anybody sending corrections of mistakes in this text, the author provides a small reward.) In the heated frenzy of research, it happens to everybody to make statements which are not based on observations. The search of statements without these properties is sometimes called the *scientific method*. But a good lie is always well prepared and told on purpose; accidental lies are frowned upon by experts.

In short, a good *general lie* seems humble and invulnerable, such as 'People have free will', and a good *specific lie* is often surprising and shaky, such as 'Yesterday I drowned'. Feelings can thus be a criterion to judge the quality of lies, if one pays careful attention to the type of statement. A number of common lies are discussed later on in this intermezzo.

To sum up, the central point in the art of lying without being caught is simple: do not tell details. Be *vague*. All methods to get to the bottom of any is to ask for details, for *precision*. For any statement, its degree of precision is the way to gauge the degree that somebody sticks his neck out. The more precision one demands, the more fragile a statement is, and the more likely the fault is found out, if there is one. This is the main reason that we chose the increase in precision as guide for our mountain ascent. The same method is used in trials. To find out the truth, investigators typically ask all the people involved a large number of questions, until as many *details* as possible come to light. When one has collected enough details, when the precision has become high enough, the situation becomes clear. Telling good lies is much harder than telling the truth; it requires an excellent imagination.

Truth is an abyss.
Democritus

To teach superstitions as truth is a most terrible thing.
Hypatia of Alexandria (ca. 355–415)

Absolute truth is what scientists claim it to be at the end of their life.
Charles Peirce (1839–1914)

* A set of not yet falsified patterns of observations on the same topic is called a (*physical*) *theory*. The term 'theory' will always be used in this sense in this walk, i.e. with the meaning 'set of correct general statements'. This use results from its Greek origin: 'theoria' means 'observation'; its original meaning, 'passionate and emphatic contemplation', summarizes all of physics in a single word. ('Theory', like 'theater', is formed from the root $\theta\acute{\epsilon}$, meaning 'the act of contemplating'.) Sometimes however, the term 'theory' is used – confusing it with 'thesis' – with the meaning of 'conjecture', as in 'your theory is wrong', sometimes with the meaning of 'model', as in 'Chern-Simons' theory and sometimes with the meaning of 'standard procedure', as in 'perturbation theory'. These incorrect uses are avoided here.

Is this statement true?

Truth is a rhetorical concept.
Paul Feyerabend (1924, Vienna–1994, Zürich)

Not all statements can be divided into true and false. There even are such statements in mathematics, such as the continuum hypothesis. This hypothesis is undecidable because it makes a statement which depends on the precise meaning of the term ‘set’; in standard mathematical usage the term is not defined precisely enough that a truth value can be assigned to the continuum hypothesis. In short, statements can be undecidable because the concepts contained in them are not sharply defined.

Statements can also be undecidable for other reasons. Curious phrases such as ‘This statement is not true’ illustrate the situation. The well-known Austrian-American logician Kurt Gödel (1906–1978) has even devised a general way to construct such statements in the domain of logic and mathematics. The different variations of these *self-referential* statements, especially popular both in the field of logic and computer science, have captured a large public.* One can construct similarly undecidable statements with terms such as ‘calculable’, ‘provable’ and ‘deducible’.

Ref. 33

In fact, self-referential statements are undecidable because they are meaningless. If the usual definition of ‘true’, namely correspondence with facts, is substituted into the sentence ‘This statement is not true’, one quickly sees that it has no meaningful content. The most famous meaningless sentence of them all was constructed by the linguist Noam Chomsky:

‘Colorless green ideas sleep furiously.’

Ref. 10

It is often used as an example for the language processing properties of the brain. But nobody in his right mind elevates it to the status of a paradox and writes philosophical discussions about it. To do that with the title of this section is a similar waste of energy.

The main reason for the popular success of self-reference is the difficulty to perceive the lack of meaning.** A good example is the statement:

This statement is false or you are an angel.

Challenge 829

One can actually deduce from it that ‘you are an angel.’ Can you see how? If you want, you can change the second half and get even more interesting statements. Such examples show that statements referring to themselves have to be treated with great care when they are investigated.

In physics, in the other natural sciences, and in legal trials these problems do not appear, since self-referential statements are not used. In fact, the work by the logicians confirms, of-

* A general introduction is given in the beautiful books by RAYMOND SMULLYAN, *Satan, Cantor, and Infinity*, 1992, *What is the name of this book? - The riddle of Dracula and other logical puzzles*, 1986, and *The lady or the tiger?*, 1982.

Ref. 34

** A well-known victim of this difficulty is Paulus of Tarsus. The paradox of the cretan poet *Epimenedes* (6th century B.C.) who said ‘All cretans lie’ is too difficult for the humour impaired Paulus, who in his letter to Titus (chapter 1, verses 12 and 13, in the christian bible) calls Epimenedes a ‘prophet’, adds some racist comments, and states that this ‘testimony’ is true. But wait; there is a final twist to this story. The sentence is not a paradox at all; a truth value can actually be ascribed to it, because the statement is not really self-referential. Can you

Challenge 812

see it? The only *genuine* paradox is ‘I am lying’, to which no truth value can be ascribed indeed.

ten rather spectacularly, that there is no way to extend the term ‘truth’ beyond the definition of ‘correspondence with facts.’

Ein Satz kann unmöglich von sich selbst
aussagen, daß er wahr ist.*

Ludwig Wittgenstein, *Tractatus*, 4.442

Observations

Knowledge is a sophisticated statement of ignorance.
Attributed to Karl Popper

The collection of a large number of true statements about a type of observations, i.e. of a large number of facts, is called *knowledge*. In case that the domain of observations is sufficiently extended, one speaks of a *science*. A *scientist* is thus somebody who collects knowledge.** We found above that an observation is classified input sticking into memory of several people. Since there is a lot of motion around, the description of all these observations is a large piece of work. As for every large task, the use of appropriate tools determines to a large extent the degree of success one can achieve. These tools, in physics and in all other sciences, fall in three groups: tools for the collection of observations, tools to communicate observations, and tools to communicate relations between observations. The latter group has been already discussed in the section on language and on mathematics. We just touch the other two.

Ref. 35

Have enough observations been recorded?

Every generation is inclined to define ‘the end of physics’
as coincident with the end of their scientific contributions.
Julian Schwinger***

Physics is an experimental science; it rests on the collection of observations. To realize this task effectively, all sorts of *instruments*, i.e. tools which facilitate observations, have been developed and built. Microscopes, telescopes, oscilloscopes, as well as thermometers, hygrometers, manometers, pyrometers, spectrometers and many others are familiar examples. The precision of many of these tools is continuously improved even today; their production is a sizable part of modern industrial production, examples being electrical measurement apparatuses and diagnostic tools for medicine, chemistry, and biology. Instruments can be

* It is quite impossible for a proposition to state that it itself is true.

** The term ‘scientist’ is a misnomer peculiar to the English language. Properly speaking, a ‘scientist’ is a follower of *scientism*, an extremist philosophical school which tried to resolve all problems through science. Therefore some sects have the term in their name. Since the English language did not have a shorter term to designate ‘scientific persons’, as they used to be called before, the term ‘scientist’ came into use, first in the United States, from the 18th century on. Nowadays the term is used in all English-speaking countries – but not outside them, fortunately.

*** Julian Seymour Schwinger (1918–1994), US-American enfant prodige, famous for his clear thinking and his excellent lectures, developer of quantum electrodynamics, winner of the 1965 Nobel prize in physics together with Tomonaga and Feynman, and thesis advisor to many famous physicists.

Ref. 36

as small as a tip of a few tungsten atoms to produce electron beams with a few volt, and as big as 27 km in circumference, producing electron beams with over 100 GV effective accelerating voltage. People have built instruments which contain the coldest known spot in the universe and instruments which can measure length variations much smaller than a proton diameter for kilometre long distances. Instruments have been put inside the earth, on the moon, on several planets, and sent outside the solar system.

In this walk, instruments are not described; many good textbooks on this topic are available. Most observations collected with them are not mentioned here. The most important results in physics are recorded in standard publications, such as the Landolt-Börnstein and the physics journals (Appendix E gives a general overview of information sources).

Will there be significant new future observations in the domain of the fundamentals of motion? At present, *in this specific domain*, even though the number of physicists and publications is at an all-time high, the number of new discoveries has diminished for many years and is now rather small; the sophistication and investment necessary for new results has become extremely high; in many cases, measurement instruments have achieved the limits of technology, of budgets, or even those given by nature; the number of new experiments showing no deviation from theoretical predictions is increasing steadily; historical papers trying to enliven boring or stuck fields of enquiry are increasing; claims of new effects which turn out to be false, due to measurement errors, self-deceit or even to fraud have become so frequent that scepticism has become the natural response. Although in many domains of science, including physics, discoveries are still expected, on the fundamentals of motion the arguments just presented seem to give new observations only a remote possibility. The task of collecting observations on motion seems to be *completed* (though not on other topics of physics). And indeed, all observations described here have been completed before the end of the twentieth century. We are not too early with our walk.

Are all observables known?

Scientists have odious manners, except when you prop up their theory;
then you can borrow money from them.
Mark Twain (1835–1910)

The most practical way to communicate observations has been developed already a long time ago: the measurement. A measurement allows effective communication of an observation to other times and places. This is not always as trivial as it sounds; in the middle ages for example, people were unable to compare precisely the ‘coldness’ of winters of two different years! Only the invention of the thermometer provided a reliable solution to this requirement. A *measurement* is thus the classification of an observation into a standard set of observations; in simple words, a measurement is a *comparison with a standard*. This definition of a measurement is the most precise and practical, and has therefore been universally adopted. For example, when the length of a house is measured, one classifies this aspect of the house into a certain set of standard lengths, namely the set of lengths defined by multiples of a unit. A *unit* is the abstract name of the standard for a certain observable. Numbers and units allow the most precise and most effective communication of measurement results.

For all measurable quantities, practical standard units and measurement methods have been defined; the main ones are listed and defined in Appendix B. All units are derived

from a few fundamental ones; this is ultimately due to the limited number of our senses: length, time, and mass are related to sight, hearing, and touch.

We call the different measurable aspects of a system its *observables*. Most observables, such as size, speed, position etc. can be described by numbers, and in this case they are *quantities*, i.e. multiples of some standard unit. Observables are usually abbreviated by (*mathematical*) *symbols*, usually letters from some alphabet. For example, the symbol c commonly specifies the velocity of light. For most observables, standard symbols have been defined by international bodies.* The symbols for those observables describing the state of an object are also called *variables*. Variables on which other observables depend are often called *parameters*. (A parameter is a variable constant.) For example, the speed of light c is a constant, the position x a variable, the temperature T often a parameter, on which e.g. the length of an object can depend. Note that not all observables are quantities; in particular, parities are not multiples of any unit.

Today the task of defining tools for the communication of observations can be considered *complete*. (For quantities, this is surely correct; for parity-type observables there could be a few examples to be discovered.) This is a simple and strong statement. Even the BIPM, the Bureau International des Poids et Mesures, has stopped to add new units.**

As a note, one can rank the greatness of a physicist by the number of observables he has introduced. Even a great scientist like Einstein, who has discovered many ‘laws’ of nature, has introduced only one new observable, namely the metric tensor for the description of gravity. Following this criterion – as well as several others – Maxwell is the most important physicist, having introduced electric and magnetic fields, the vector potential, and several other material dependent observables. For Heisenberg, Dirac and Schrödinger, the wavefunction describing electron motion could be counted as half an observable (in fact it is a quantity necessary to calculate measurement results, but not itself an observable). By the way, even introducing *any* word which is taken up by others is the a rare event; ‘gas’, ‘entropy’ and only a few others are such examples. It was always much more difficult to discover an observable than to discover a ‘law’; usually, observables are developed by many people together. This is shown from a simple aspect of modern science: many ‘laws’ bear people’s names, but almost no observables.

The list of observables necessary to describe nature being complete, does this mean that automatically one knows all the patterns or rules of nature? No; in the history of physics, observables have usually been defined and measured long *before* the precise rules connecting them were found. For example, all observables used in the description of motion itself, such as time, position and its derivatives, momentum, energy, and all the thermodynamic quantities have been defined during or before the nineteenth century, whereas the most precise versions of the patterns or ‘laws’ of nature connecting them, special relativity and non-equilibrium thermodynamics, have been found only in the twentieth century. The

* All mathematical symbols used in this walk, together with the alphabets from which they are taken, are listed in Appendix A on notation. They follow international standards whenever they are defined. The standard symbols of the physical quantities, as defined by the International Standards Organisation (ISO), the International Union of Pure and Applied Physics (IUPAP) and the International Union of Pure and Applied Chemistry (IUPAC), can be found for example in the *bible*, i.e. the *CRC Handbook of Chemistry and Physics*, CRC Press, Boca Raton, 1992.

** The last, the *katal*, was introduced in 1999. All units are explained in Appendix B.

same is true for all observables connected to the electromagnetic interaction, and all those connected to the gravitational interaction, except perhaps the metric tensor. The respective patterns of nature, quantum electrodynamics and general relativity, have been discovered long after the corresponding observables. The observables discovered last are the fields of the strong and of the weak nuclear interactions. Also in this case the patterns of nature were formulated much later.*

Do observations take time?

An observation is an interaction with some part of nature leading to the production of a record, such as a memory in the brain, data on a tape, ink on paper, or any other fixed process applied to a support. The irreversible interaction process is often called *writing* the record. Obviously, writing takes a certain amount of time; zero interaction time would give no record at all. Therefore any recording device, also our brain, always records some *time average* of the observation, however short it may be.

What we call a fixed image, be it a mental image or a photograph, always is the time average of a moving situation. Without time averaging, we would not have any fixed memories. On the other hand, the blurring any time averages introduces, hides the details; and in our quest for precision, at a certain moment, these details are bound to become important. The discovery of these details will begin in the second part of the walk, the one centred on quantum theory. In the third part of our mountain ascent we will discover that there is a shortest possible averaging time, and that observations of that short duration show so many details that we cannot even distinguish particles from empty space. All our concepts of everyday life appear only after relatively long time averages. The search of an average-free description of nature is one of the big challenges remaining in our adventure.

Is induction a problem in physics?

Nur *gesetzmäßige* Zusammenhänge sind *denkbar*.**
Ludwig Wittgenstein, *Tractatus*, 6.361

There is a tradition of opposition between adherents of induction and of deduction.
In my view it would be just as sensible for the two ends of a worm to quarrel.
Alfred North Whitehead (1861–1947)

Induction is the usual term used for the act of taking, from a small and finite number of experiments, general conclusions about the outcome of *all* possible experiments performed in other places, or at other times. In a sense, it is the technical term for the sticking out of one's neck that is necessary in every scientific statement. Induction has been a major topic of discussion for science commentators. Frequently one finds the remark that knowledge in general, and physics in particular, relies on induction for its statements. Following some,

* Can one talk about observations at all? It is many a philosopher's hobby to discuss whether there actually is an example for an 'Elementarsatz' mentioned by Wittgenstein in his *Tractatus*. There seems to be at least one which fits: *Differences exist*. It is a simple sentence; at the end of our walk, it will play a central role.

** Only connexions that are *subject to law* are *thinkable*.

induction is a type of hidden belief underlying all sciences and at the same time in contrast with it.

To avoid any waste of energy, we make only a few remarks. The first point can be deduced from a simple experiment. Try to convince an induction critic to put his hand into fire. Nobody who calls induction a belief will conclude from a few unfortunate experiences in the past that such an act will also be dangerous in the future... In short, somehow induction works.

A second point is that physical universal statements are always clearly stated; they are never hidden. The refusal to put the hand into fire is a consequence of the invariance of observations under time and space translations. Indeed, all-statements of this type form the very basis of physics. However, no physical statement is a belief only because it is universal; it always remains open to experimental checks. Physical induction is not a hidden method of argumentation, it is an explicit part of experimental statements. In fact, the complete list of 'inductive' statements used in physics is given in the table on page 137. These statements are so important that they have been given a special name: they are called *symmetries*. The table lists all known symmetries of nature; in other words, it lists all inductive statements used in physics.

Perhaps the best argument for the use of induction is that there is no way to avoid it when thinking. There is no way to think or to talk without using concepts, i.e. without assuming that most objects or entities have the same properties over time. The only sentences which do not use induction, the sentences of logic, do not have any content (Tractatus, 6.11). Without induction, one cannot classify observations at all! Evolution has given us memory and a brain because induction works. To criticize induction is not to criticize natural sciences, it is to criticize the use of thought in general. One should never take too seriously people who themselves do what they criticize in others; sporadically pointing out the ridicule of this endeavour is just the right amount of attention they deserve.

The topic could be concluded here, were it not for some interesting developments in modern physics which put two more nails in the coffin of arguments against induction. First of all, whenever in physics one makes statements about all experiments, all times, all velocities, etc., such statements are about a *finite number* of cases. We know today that infinities, both in size and in number, do not occur in nature. The infinite number of cases appearing in statements in classical physics and in quantum mechanics are apparent, not real, and due to human simplifications and approximations. Statements that a certain experiment gives the same result 'everywhere' or that a given equation is correct for 'all times', always encompass only a *finite* number of examples. A lot of otherwise often instinctive repulsion to such statements is avoided in this way. In the sciences, as well as in this book, 'all' *never* means an infinite number of cases.

Finally, it is well known that taking conclusions from a few cases to many is false when the few cases are independent of each other. However, it is correct if the cases are interdependent. From the fact that somebody found a penny on the street on two subsequent months, he cannot follow that he will find one the coming month. Induction is only correct if one knows that all cases have similar behaviour, e.g. because they follow from the same origin. For example, if a neighbour with a hole in his pocket carries his salary across that street once a month, and the hole always opens at that point because of the beginning of stairs, then the conclusion would be correct. It turns out that the results of modern physics

Ref. 35
Challenge 846

encountered in the third part of our walk show that all situations in nature are indeed interdependent, and thus prove in detail that what is called 'induction' is in fact a logically correct conclusion.

In the progress of physics,
the exception always turned out to be the general case.

The quest for precision and its implications

Der Zweck der Philosophie ist die logische Klärung der Gedanken.*
Ludwig Wittgenstein, *Tractatus*, 4.112

To talk well about motion means to talk precisely. Precision requires avoiding three common mistakes in the description of nature:

Concepts should never have a contradiction built into their definition. For example, any phenomenon occurring in nature evidently is a ‘natural’ phenomenon; therefore, talking either about ‘supernatural’ phenomena or about ‘unnatural’ phenomena is a mistake that nobody interested in motion should let go by unchallenged; the terms contain a logical contradiction. Naturally, *all* observations are natural. By the way, there is a reward of more than a million dollars for anybody showing the opposite. In over twenty years, nobody has yet been able to collect it. Ref. 40

Concepts should not have unclear or constantly changing definitions. Their content and their limits must be kept constant and explicit. This mistake is often encountered when one talks to crackpots or to populist politicians, and distinguishes them from more reliable thinkers. Also physicists fall into the trap; for example, there is of course only a *single* (physical) universe, as even the name says. Talking about more than one universe is an increasingly frequent error of thought. Ref. 41

Concepts should not be used outside their domain of application. Everybody has succumbed to the temptation to transfer results from physics to philosophy without checking the content. An example is the question: ‘Why do particles follow the laws of nature?’ The question is due to a misunderstanding of the term ‘law of nature’ and to a confusion with the laws of the state.** Remembering that ‘law of nature’ simply means ‘pattern’, ‘property’ or ‘description of behaviour’, and rephrasing the question correctly as ‘Why do particles behave in the way we describe their behaviour?’ one recognizes its senselessness.

In the course of our walk, we will often be tempted by these three mistakes. A few such situations follow, together with the way to avoid them.

Consistency is the last refuge of the unimaginative.
Oscar Wilde (1854, Dublin–1900, Paris)

What are interactions?

The whole is always more than the sum of its parts.
Aristotle, *Metaphysica*, 10f–1045a.

In the physical description of nature, the whole is always *more* than the sum of its parts. Actually, the difference between the whole and the sum of its parts is so important that it gets a special name: the *interaction* between the parts. For example, the energy of the whole minus the sum of the energies of its parts is called the energy of interaction. In fact, the study of interactions is the main topic of physics. In other words, physics is concerned *primarily*

* Philosophy aims at the logical clarification of thoughts.

** If nature were governed by ‘laws’, they could be changed by parliament.

with the difference between the parts and the whole, contrary to what is often written by bad journalists or other sloppy thinkers.

Note that the term ‘inter-action’ is based on the general observation that anything which affects other things is in turn affected by them; interactions are *reciprocal*. For example, if a body changes the momentum of a second body, then the second changes the momentum of the first by the same (negative) amount. This reciprocity of interactions is the reason that anybody using the term is a heretic for monotheistic religions, since reciprocity implicitly denies the immutability of the deity.

Remembering the definition of interaction also settles the frequently heard question on whether in nature there are ‘emergent’ properties, i.e. properties of systems which cannot be deduced from the properties of their parts *and* of their interactions. The idea of ‘emergent’ properties is a product of minds with a restricted horizon, unable to see the richness of consequences that general principles can produce.

The simple definition of interaction just given, so boring it sounds, leads to surprising conclusions. Take the atomic idea of Democritus in its modern form: nature is made of vacuum and of particles.

The first consequence is the *paradox of incomplete description*: Experiments show that there are interactions between vacuum and particles. But interactions are differences between parts and the whole, in this case therefore between vacuum and particles on one hand, and the whole on the other. We thus have deduced that nature is not made of vacuum and particles alone.

The second consequence is the *paradox of overcomplete description*: Experiments also show that interactions happen through exchange of particles. But we have counted particles already as basic building blocks. Does this mean that the description of nature by vacuum and particles is an overdescription, counting things double?

We will resolve both paradoxes in the third part of the mountain ascent.

What is existence?

You know what I like most?
Rhetorical questions.

Assume a friend tells you ‘I have seen a *grampus* today!’ You would naturally ask how it looks. What do we expect from the answer? We expect something like ‘It’s an animal with a certain number of heads similar to a *X*, attached to a body like a *Y*, with wings like a *Z*, it make noises like a *U* and it felt like a *V*’ – the letters denoting some other animal or object. Generally speaking, in the case of an object, this scene from Darwin’s voyage to South America shows that in order to talk to each other, one first of all needs certain basic, common concepts (‘animal’, ‘head’, ‘wing’, etc.). In addition, for the definition of a new entity we need a characterization of its parts (‘size’, ‘colour’), of the way these parts relate to each other, and of the way the whole interacts to the outside world (‘feel’, ‘sound’). In other words, for an object to exist, one must be able to give a list of relations with the outside world. An object exists if one can interact with it. (Is observation sufficient to determine existence?)

For an abstract concept, such as ‘time’ or ‘superstring’, the definition of existence has to be refined only marginally: (*physical*) *existence is the ability to describe interactions*. This

definition applies to trees, time, virtual particles, imaginary numbers, entropy, and many others. It is thus pointless to discuss whether a physical concept ‘exists’ or whether it is ‘only’ an abstraction used as a tool for descriptions of observations. * The two possibilities coincide. The point of dispute can only be whether the description provided by a concept is or is not *precise*.

Do things exist?

Wer Wissenschaft und Kunst besitzt,
 Hat auch Religion;
 Wer jene beiden nicht besitzt,
 Der habe Religion. **
 J.W. von Goethe, *Zahme Xenien*, IX

Using the above definition of existence, the question becomes either trivial or imprecise. It is trivial in the sense that things necessarily exist if they describe observations, since they were defined that way. But perhaps the questioner meant to ask: Does reality exist independently of the observer?

Using the above, this question can be rephrased: Do the things one observes exist independently of observation? After thousands of years of extensive discussion by professional philosophers, logicians, sophists, amateurs, etc., the result still remains: Yes, because the world did not change after greatgrandmother died. The disappearance of observers does not seem to change the universe. These experimental findings can be corroborated by filling in the definition of ‘existence’ into the question, which then becomes: Do the things one observes interact with other aspects of nature when they do not interact with people? The answer is evident. Recent popular books on quantum mechanics fantasize about the importance of the ‘mind’ of observers – whatever this term may mean; they provide pretty examples of authors who see themselves as irreplaceable centre of the universe, seemingly having lost the ability to do otherwise.

Of course there are other opinions about existence of things. The most famous one is by the Irishman George Berkeley (1685–1753) who rightly understood that thoughts based on observation alone, if spreading, would undermine the basis of a religious organization in which he was one of the top managers. To counteract this, in 1710 he published *A treatise concerning the principles of human knowledge*, a book denying the existence of the material world. This reactionary book became widely known in similar circles (it was a time when few books were written) even though it is based on a fundamentally flawed idea: it assumes that the concept of ‘existence’ and that of ‘world’ can be defined independently from each other. (You may be curious to try the feat.)

Challenge 914

Berkeley had two aims when he wrote his book. First, he tried to deny the capacity of people to arrive at judgments on nature or on any other matter *from their own experience*.

* For mathematical concepts, existence has a different meaning: a mathematical concept is said to exist if it has no built-in contradictions. This is a much weaker requirement; it is thus wrong to deduce physical existence from mathematical existence. This error was common; since Pythagoras it was often stated that perfect mathematical concepts must therefore exist in nature. Examples are euclidean space and its geometry, continuity of space and time, and as we will find out, sets.

** He who possesses science and art, also has religion; he who does not possess the two, better have religion.

This is a section of the freely downloadable e-textbook

Motion Mountain

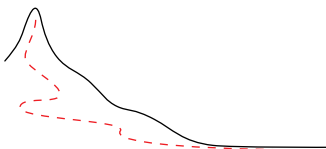

Hiking beyond space and time along the concepts of modern physics

available at
www.motionmountain.org

Copyright © 1997, 1998, 1999, 2000, 2001, 2002 by Christoph Schiller

To the kind reader

In exchange for getting this section for free, I ask you for a short email on some of the following:

- Which page was boring?
- Did you find any mistakes?
- What else were you expecting?
- What was hard to understand?

Of course, any other suggestion is welcome. This section is part of a physics text written over many years. The text lives and grows through the feedback from its readers, who help to improve and to complete it. For a particularly useful contribution (send it in english, italian, dutch, german, spanish, portuguese, or french) you will be mentioned in the foreword of the text, or receive a small reward, or both.

Enjoy!

Christoph Schiller
cs@motionmountain.org

Challenge 897

Secondly, he also tried to deny the *ontological reach* of science, i.e. the conclusions one can take from experience on the questions about human existence. Even though he is generally despised, he actually achieved his main aim: he is the originator of the statement that science and religion do not contradict each other, but *complement* each other. This widely cited belief is still held dearly by many up to this day. However, when searching for the origin of motion, beliefs such as this one stand in the way. Carrying them means carrying oversized baggage: it prevents from reaching the top of motion mountain.

Does the void exist?

Teacher: 'What is there between the electrons and the nucleus?'

Student: 'Nothing, only air.'

Natura abhorret vacuum.
Antiquity

In philosophical discussions *void* is usually defined as non-existence. It then becomes a game of words to ask whether one has to answer this question by yes or no. The expression 'existence of non-existence' is either a contradiction or at least unclearly defined; the topic would not seem of deep interest. However, similar questions do appear in physics, and one should be prepared to see the difference to the previous one. Does the vacuum exist? Does empty space exist? Or is the world 'full' everywhere, as the more conservative biologist Aristotle maintained? In the past, people used to be killed if they gave the answer not accepted by authorities.

It is not obvious but nevertheless essential that the modern physical concepts of 'vacuum' or 'empty space' are not the same as the philosophical concept of 'void'. 'Vacuum' is not defined as 'non-existence'; on the contrary, it is defined as the absence of matter and radiation, and is an entity with specific observable properties, such as the number of its dimensions, its electromagnetic constants, its curvature, its vanishing mass, its interaction with matter through curvature and through its influence on decay, etc. (A table of the properties of the physical vacuum is given on page 378.) Historically, it took a long time to clarify the distinction between physical vacuum and philosophical void. People confused the two concepts and debated the question in the section title for more than two thousand years; the first to answer it positively, with the courage to try to look through the logical contradiction to the underlying physical reality, were Leucippos and Democritus, the most daring thinkers of antiquity. Their speculations in turn elicited the reactionary response of Aristotle, rejecting the concept of vacuum. He and his disciples propagated the belief about nature's *horror of the vacuum*.

The discussion changed completely in the 17th century, when the first experimental method to realize a vacuum was discovered by Torricelli. * Using mercury in a glass tube, he produced the first human made vacuum. Can you guess how? Arguments against the existence of the vacuum reappeared around 1900, when it was argued that light needed 'aether' for its propagation, using almost the same arguments used two hundred years earlier, just

Challenge 931

* Evangelista Torricelli (1608, Faenza–1647), Italian physicist, pupil and successor of Galileo. The pressure unit 'torr' is named after him.

by changing the words. However, experiments failed to detect any supposed property of this unclearly defined concept. Experiments in the field of general relativity showed that the vacuum can move – though in a completely different way than the aether was expected to – that the vacuum can be bent, and that it tends to move back not normal. Then, in the late twentieth century, quantum field theory again argued against the existence of a true vacuum and in favour of a space full of virtual particle-antiparticle pairs, culminating in the discussions around the cosmological constant.

See page 669

The title question is settled conclusively only in the third part of this walk, in a rather surprising way.

See page 690

Is nature infinite?

There is a separation between state and church, but not yet between state and science.
Paul Feyerabend (1924–1994)

Most of the modern discussions about set theory centre on the ways to define the term ‘set’ for various types of infinite collections. For the description of motion this leads to two questions: Is the universe infinite? And is it a set? We begin with the first one. Illuminating it from various viewpoints, one quickly discovers that it is equally simple and imprecise.

Firstly, does one need infinite quantities to describe nature? In classical and quantum physics one does indeed, e.g. in the case of space-time. Is this necessary? This issue is settled in the third part of this mountain ascent.

But that does not help now. A second point is that any set can be finite in one aspect and infinite in another. For example, it is possible to walk a finite length in an infinite amount of time. It is also possible to sweep over an infinite length in a finite amount of time, even in relativity, as explained there.

Challenge 948

For example, these connections make discussions on whether humanity is near the ‘end of science’ rather difficult. The amount of knowledge and the time to discover it are unrelated. Depending on the speed with which one advances through it, the end of science can be near or unreachable. In practice, scientists have thus the power to *make* science infinite or not, e.g. by reducing the speed of progress. Since funding is needed for their activity, everybody can guess which stand of the discussion is usually taken.

Ref. 44

Thirdly, is it possible at all to say of nature or of one of its aspects that it is *infinite*? Can such a statement be compatible with observations? It seems that every statement claiming that in nature something is infinite is a belief, and not taken from observations. We will encounter this issue several times later on.

Challenge 965

In short, the universe cannot be said to be infinite. On the other hand, can nature be *finite*? At first sight, this would be the only possibility left. But even though many have tried to describe a universe as finite in all its aspects, they were not successful. In order to see the problems it brings, we continue with the other question mentioned above:

Is the universe a set?

There is a simple fact questioning whether the universe is a set. For 2500 years it has been said that the universe is made of vacuum and particles. That implies that the universe is made

Ref. 45

of a certain *number* of particles. Perhaps the only person to have taken this conclusion to the limit was the English astrophysicist Arthur Eddington (1882–1944), who wrote:

I believe there are 15,747,724,136,275,002,577,605,653,961,181,555,468,044,717,914,527, 116,709,366,231,425,076,185,631,031,296 protons in the universe and the same number of electrons.

Ref. 46

Eddington has been ridiculed over and over for this statement and for his beliefs leading to it. His arguments for this result were indeed based on his personal preferences for certain pet numbers. However, one should not laugh too loud. In fact, for 2500 years, almost all scientists have been thinking along the same line, with the only difference that they leave the precise number unspecified! In fact, *any other number* put into the above sentence would be equally ridiculous. Avoiding to name it is only a cowards' way to avoid looking at this unclear side of the particle description of nature.

Is there such a number at all? If you smiled at the sentence by Eddington, or if you shook your head over it, it may mean that you instinctively believe that nature is not a set. Is this so? Whether we define the universe as the totality of events or of observations, or as the totality of all space-time points and of all objects, we imply that space-time points can be distinguished, that objects can be distinguished, and that both can be distinguished from each other. We always assume that nature is separable. But is this correct?

The question is important. The ability to distinguish space-time points and particles from each other is often called *locality*. Thus the universe is a set or separable if and only if our description of it is local.* And in everyday life, locality is observed without exception.

In daily life we also observe that nature is separable and a whole at the same time. It is a 'many that can be thought as one': in daily life nature is a set. Indeed, the basic characteristic of nature is its diversity. In the world around us we observe changes and differences; we observe that nature is separable. Furthermore, all aspects of nature belong together: there are relations between these aspects, usually called 'laws,' expressing that the different aspects of nature form a whole, usually called universe.

Challenge 982

In other words, the possibility to describe observations with help of 'laws' follows from the separability of nature. The more precisely the separability is specified, the more precisely the 'laws' can be formulated. Indeed, if nature were not separable or were not a unity, we could not explain why stones fall downwards. Thus we are led to speculate that we should be able to deduce all 'laws' from the fact that nature is separable.

In addition, only the separability allows us to describe nature at all. A description is a classification, i.e. a mapping between certain aspects of nature and certain concepts, i.e. certain combinations of sets and relations. Since the universe is separable, it can be described with help of sets and relations. Both are separable entities with distinguishable parts. A precise description is commonly called an understanding. In short, the universe is comprehensible only because it is separable.

Moreover, only the separability of the universe makes our brain such a good instrument. The brain is built from a large number of connected components, and only the brain's sep-

* In quantum mechanics also other, less clear definitions of locality are used. We will mention them in the second part of this text. The issue mentioned here is a different, more fundamental one, and not connected with the one of quantum theory.

arability allows it to function. In other words, thinking is only possible because nature is separable.

Finally, only the separability of the universe allows to distinguish reference frames, and thus define all symmetries at the basis of our description. And in the same way as separability is thus necessary for *covariant* descriptions, the unity of nature is necessary for *invariant* descriptions. In other words, the so-called ‘laws’ of nature are based on the fact that nature is both separable and unifiable – that it is a set.

These arguments seem overwhelmingly to prove that the universe is a set. However, these arguments only apply to everyday experience, everyday dimensions, and everyday energies. Is nature a set also *outside* the domains of daily life? Are objects different at all energies, i.e. when looking at them with the highest precision possible? Are objects countable at all energies? We will discover in the third part of our mountain ascent, that none of this happens to be the case in nature, confirming our suspicion about the number of particles. The consequences will be extensive as well as fascinating. As an example, try to answer the following: if the universe is not a set, what does that mean for space and time?

See page 715

Challenge 999

Does the universe exist?

Each progressive spirit is opposed by a thousand men appointed to guard the past.
Maurice Maeterlink (1862–1949) Belgian dramatist

Following the definition above, existence of a concept means its usefulness to describe interactions. Now, there are two common definitions of the universe. The first is to mean the totality of all matter, energy and space-time. But this results in a strange consequence: since nothing can interact with this totality, we cannot claim that the universe exists.

So let us take the more conservative view, namely that the universe is only the totality of all matter and energy. But obviously, also in this case it is impossible to interact with the universe. Are you able to give a few arguments?

Challenge 1016

In short, we arrive at the conclusion that the universe does not exist. We will indeed confirm this result in more detail later on in our walk. In particular, that means that it does not make sense to even try to answer *why* the universe exists. The best answer might be: because of furiously sleeping, colourless green ideas.

See page 717

Ref. 10

What is creation?

(Gigni) De nihilo nihilum,
in nihilum nil posse reverti.*
Persius, *Satira*, III, v. 83-84.

Ref. 47

The term is often heard when talking about nature. It is used in various contexts with different meanings:

One talks of creation as characterization of human actions, such as observed in a painting artist or a typing secretary. Obviously, this is a type of change. In the classification of change introduced at the beginning of our walk, such changes are movements of objects, such as

* Nothing (can appear) from nothing, nothing can disappear into nothing.

the electrons in the brain, the molecules in the muscles, the material of the paint, or the electrons inside the computer. This type of creation is thus a special case of motion.

One also talks of creation in the biological or social sense, such as in ‘the creation of life’, or ‘creation of a business’, or ‘the creation of civilisation’. These events are forms of growth or of self-organization; again, special cases of motion.

In physics one often says that a lamp ‘creates’ light or that a stone falling into a pond ‘creates’ water ripples. Similarly, one talks of ‘pair creation’ of matter and antimatter. It was one of the important discoveries of physics that all these processes are special types of motion, namely excitation of fields.

See page 511

See page 575

In popular pieces on cosmology, ‘creation’ is also a term commonly applied, or better misapplied, to the *big bang*. However, the expansion of the universe is a pure example of motion, and contrary to a frequent misunderstanding, the description of the big bang contains no process which does not fall into one of the previous three cases, as shown in the chapter of general relativity. Relativistic cosmology provides more reasons for which the term ‘creation’ is not applicable to the big bang. First of all, it turns out that the big bang was not an event. Secondly, it was not a beginning. Thirdly, it did not provide a *choice* from a large set of possibilities. The big bang does not have any properties attributed to the term ‘creation’.

See page 299

See page 298

In summary, one concludes that in all cases, *creation is a type of motion*. (The same applies to the notions of ‘disappearance’ and ‘annihilation’.) No other type of creation is observed in nature. In particular, the naive sense of ‘creation’, namely ‘appearance from nothing’ – *ex nihilo* in Latin –, is never observed in nature. All observed types of ‘creation’ require space, time, forces, energy and matter for their realisation.

The opposite of creation is *conservation*. The central statements of physics are conservation theorems: for energy, for mass, for linear momentum, for angular momentum, for charge, for spin, etc. In fact, every conservation ‘law’ is a detailed and accurate rejection of the concept of creation. Already the ancient Greek idea of atoms contains this rejection. Atomists stated that there is no creation and no disappearance, only motion of atoms, only transformation of matter. In other words, the idea of atom was a direct consequence of the negation of creation. It took humanity over 2000 years to stop putting people in jail for talking about atoms, as still happened to Galileo.

See page 142

However, there is one exception in which the naive concept of creation does apply: it describes what magicians do on stage. When a magician makes a rabbit appear from nowhere, one indeed experiences ‘creation’ from nothing. At its best such magic is a form of entertainment, at its worst, a misuse of gullibility. The idea that the universe results from either of the two does not seem appealing; on second thought though, maybe looking at the universe as the ultimate entertainment could open up a fresh and more productive approach to life.

Voltaire (1694–1778) popularized an argument against creation often used in the past: we do not know whether it has taken place or not. Today the situation is different: we *do* know that it has *not* taken place, because creation is a type of motion, and, as we will see in the third part of our mountain ascent, motion did not exist near the big bang.

Have you ever heard the expression ‘creation of the laws of nature’? It is one of the most common examples of disinformation. First of all, this expression confuses the ‘laws’ with nature itself. A description is not the same as the thing; everybody knows that giving to his beloved the description of a rose is different from giving an actual rose. Secondly,

the expression implies that nature is the way it is because it is somehow ‘forced’ to follow the ‘laws’, a rather childish, and moreover incorrect view. And thirdly, the expression assumes that it is possible to ‘create’ descriptions of nature. But a ‘law’ is a description, and a description by definition cannot be created: the expression makes no sense at all. The expression ‘creation of the laws of nature’ is the epitome of confused thinking.

It may well be that calling a great artist ‘creative’ or ‘divine’, as became the use during the renaissance, is not a blasphemy, but simply an encouragement to the gods to try to do similarly well. In fact, whenever the term ‘creation’ is used to mean anything else than some form of motion, one is discarding both observations and human reason. It is one of the last pseudo-concepts of our modern time; no expert on motion should forget this. One cannot escalate motion mountain without getting rid of it. We will encounter the next temptation to bring it back in during the study of quantum theory.

See page 655

Every act of creation is first of all an act of destruction.
Pablo Picasso (1881–1973), painter.

Is nature designed?

In the beginning the universe was created. This has made a lot
of people very angry and has been widely regarded as a bad move.
Douglas Adams

The tendency to conclude from existence of an object to its creation is widespread. Some jump to this conclusion every time they see a beautiful landscape. This habit stems from the prejudice that a beautiful scene implies a complex description, in turn implying complex building instructions, and therefore *design*.

There are several mistakes in this conclusion. First of all, beauty is not necessarily a consequence of complexity. Usually it is the opposite, as the study of chaos and of self-organization shows. These research fields demonstrated how many beautifully complex shapes and patterns can be generated with extremely simple descriptions. True, for most human artefacts, complex descriptions indeed imply complex building processes. A personal computer is a good example. But in nature, this is not the case. We have seen above that the information to construct a human body is about a million times smaller than the information stored in the brain alone. Similar results have been found for plant architecture and for many other examples of patterns in nature. The simple descriptions behind the apparent complexities of nature have been and are still being uncovered by the study of self-organization, chaos, turbulence, and fractal shapes. In nature, complex structures derive from *simple* processes. Beware of anybody saying that nature has ‘infinite complexity:’ apart from the fact that complexity is not a measurable entity, despite many attempts, all known complex system are describable by (relatively) few parameters.

Ref. 48

The second mistake: complex descriptions for any object do not imply design; they only imply that the object has a long story of evolution behind it. The correct deduction is: something of large complexity, i.e. of low entropy, exists; therefore it has *grown*, i.e. it has been transformed through input of energy over time. This deduction applies to flowers, mountains, stars, life, people, watches, books, personal computers and works of arts; in fact it applies to all objects in the universe.

Third, the idea of ‘instruction’ is often taken to mean that some unknown intelligence is somehow pulling the strings of the world’s stage. But the study of nature has shown in every single case that there is no such hidden intelligence. An instruction is a list of orders to an executioner. But there are no orders in nature, and no executioners. There are no ‘laws’ of nature, only descriptions of processes. Nobody is building a tree; the tree is an outcome of the motion of molecules making it up. No molecule is given any instructions. The idea of design is an ideology, born from an analogy with monarchy or even tyranny, and a typical anthropomorphism.

In fact there is not a single example of observation in nature which implies or requires either design or creation. However, that is not a reason to deny that the phenomena of nature often inspires us with awe. The wild beauty of nature often show us how *small* a part of nature we actually are, both in space and in time. Remaining open to the power and to the details of this experience is of central importance for the rest of this adventure.

What is a description?

In theory, there is no difference between theory and practice.
In practice, there is.

Following standard vocabulary usage, a description of an observation is a list of the details. The above example of the grampus showed this clearly. In other words, a *description* of an observation is the act of categorizing it, i.e. of comparing, by identifying or distinguishing, the observation with all the other observations already made. A description is a classification. In short, *to describe means to see as an element of a larger set.*

See page 456

A description is like the ‘you are here’ sign on a road map in a foreign city. It shows, out of a set of possible positions, the particular one one wants to describe. For example, the formula $a = GM/r^2$ is a description of the observations relating motion to gravity because it classifies the observed accelerations a according to distance to the central body r and to its mass M , and sees each specific case as an example of a general pattern. The habit of generalizing is one reason for the often disturbing dismissiveness of scientists: when they observe something, their professional deformation makes them usually see it as a special case of a known phenomenon and thus keeps them from being taken aback or from being enthusiastic about it.

A description is thus the opposite of a *metaphor*; the latter is an analogy relating different *special* cases only, in contrast to a precise relation between *general* cases, namely a physical *theory*.

Felix qui potuit rerum cognoscere causas,
atque metus omnis et inexorabile fatum
subjecit pedibus strepitumque acherontis avari
Vergilius, georg. 2, 490 ss.

Reason, purpose, and explanation

Der ganzen modernen Weltanschauung liegt die Täuschung zugrunde, daß die

sogenannten Naturgesetze die Erklärungen der Naturerscheinungen seien.*
Ludwig Wittgenstein, *Tractatus*, 6.371

- Why are the leaves of most trees green? Because they absorb red and blue light. Why do they absorb those colours? Because they contain chlorophyll. Why is chlorophyll green? Because all chlorophyll types contain magnesium between four pyrrole groups, and this chemical combination gives green colour, as a result of its quantum mechanical energy levels. Why do plants contain chlorophyll? Because that is what land plants can synthesize. Why only that? Because all land plants originally evolved from the green algae, who are able to synthesize only this compound, and not the compounds found in the blue or in the red algae, which are also found in the sea.
- Why do children climb trees, and why do some people climb mountains? Because of the sensations they experience during their activity; the feelings of achievement, the symbolic act to go upwards, the wish to get a wider view of the world are part of this type of adventure.

The ‘why’-questions in the two preceding paragraphs show the difference between reasons and purposes (although these two terms are not defined the same way by everybody). A *purpose* or *intention* is a classification applied to actions of humans or animals; strictly said, it specifies the quest for a feeling, namely for some type of satisfaction felt after completion of the action. On the contrary, a *reason* is a specific relation of a fact with the rest of the universe, usually its past. What we call a reason always rests outside the observation itself, whereas a purpose always is internal to it.

Reasons and purposes are the two possibilities of explanations, i.e. the two possible answers to questions starting with ‘why’. Usually, physics is not concerned with purpose or with feelings of people, mainly because its original aim, to talk about motion with precision, does not seem to be achievable in this domain. Therefore, *physical* explanations of facts are never purposes, but are always reasons. A *physical explanation* of an observation is always the description of its relation with the rest of nature.**

Ref. 49

This means that – contrary to an often heard opinion – any question starting with ‘why’ is accessible to physical investigation, as long as it asks for a *reason*, not a purpose. In particular, questions such as ‘why do stones fall downwards and not upwards?’ or ‘why do electrons have that value of mass, and why do they have mass at all?’ or ‘why does space have three dimensions and not thirtysix?’ fall under this class, as these ask for the connection between specific observations and more general ones. Of course, not all demands for explanation have been answered yet, and there still are problems to be solved. Our present trail only leads along a few answers to some of the questions about motion.

The most general quest for an explanation derives from asking: why is the universe the way it is? The topic is covered in our mountain ascent using the two usual approaches, namely:

* The whole modern conception of the world is founded on the illusion that the so-called laws of nature are the explanations of natural phenomena.

** It is important to note that purposes are *not* put aside because they pertain to the future, but because they are inadmissible anthropomorphisms. In fact, for deterministic systems, one can equally say that the future is actually a *reason* for the present and the past, a fact often forgotten.

Unification and demarcation

Studying the properties of motion, paying incessant attention to increase the accuracy of description, one finds that explanations are mostly of two types: *

- ‘It is like all such cases; also this one is described by ...’ The situation is recognized as a *special case* of a general behaviour.

- ‘If it was different, one would have ..., which is in contrast with the observation that ...’ The situation is recognized as the *only possible case*. **

In other terms, the first approach is to formulate rules or ‘laws’ which describe larger and larger numbers of observations, and compare the observation with them. This endeavour is called the *unification* of physics – by those who like it; those who don’t like it, call it ‘reductionism’. For example, one finds that the same rule describes the flight of a tennis ball, the motion of the tides at the sea shore, the timing of ice ages, and the time at which the planet Venus ceases to be the evening star and starts to be the morning star. These processes are all consequences of universal gravitation. Similarly, it is not evident that the same rule describes the origin of the colour of the eyes, the formation of lightning, the digestion of food and the working of the brain. These processes are described by quantum electrodynamics.

Unification has its most impressive successes when it predicts an observation which was not made before. A famous example is the existence of antimatter, predicted by Dirac when he investigated the solutions of an equation that describes the precise behaviour of matter.

The second procedure in the search for explanations is the elimination of all other imaginable alternatives in favour of the actually correct one. This endeavour has no commonly accepted name: it could be called the *demarcation* of the ‘laws’ of physics – by those who like it; the others often call it ‘anthropocentrism’, or simply ‘arrogance’.

When one discovers that light travels in such a way to take the shortest possible time to its target, or when one describes motion by a principle of least action, or when one discovers that trees are branched in such a way that they achieve the largest effect with the smallest effort, one is using a demarcation viewpoint.

In summary, unification, answering ‘why’ questions, and demarcation, answering ‘why not’ questions, are typical for the progress throughout the history of physics. One can say that the dual aspects of unification and demarcation form the the composing and the opposing traits of physics. They stand for the desire to *know everything*.

However, neither demarcation nor unification can explain the universe. Can you see why? In fact, apart from unification and demarcation, there is a third possibility which merges the two and does allow to say more about the universe. Can you find it? Our walk will automatically lead to it later on.

Challenge 1050

Challenge 1033

* Are these the only possible ones?

** These two cases have not to be confused with similar sentences which *seem* explanations, but which aren’t:

- ‘It is like the case of ...’ A similarity with another *single* case is *not* an explanation.
- ‘If it were different, it would contradict the idea that ...’ A contradiction with an *idea* or with a theory is *not* an explanation.

Pigs, apes, and the anthropic principle

Das wichtigste Instrument des Wissenschaftlers ist der Papierkorb.*

The wish to achieve demarcation of the patterns of nature is most interesting when one follows the consequences of different rules of nature until one finds them in contradiction with the most striking observation: human existence itself. In this special case the program of demarcation is often called the *anthropic principle* – from the Greek *ἄνθρωπος*, meaning ‘man’.

For example, if the gravitational constant were different from the actual one, the resulting temperature change on the earth would have made impossible the emergence of life, which needs liquid water. Similarly, our brain would not work if the moon did not circle the earth. Only because the moon revolves around our planet, the earth’s magnetic field becomes big enough to protect the earth by deviating most of the cosmic radiation that would otherwise make all life on earth impossible, but leave enough of it to induce the mutations necessary for evolution. It is also well-known that fewer large planets in the solar system would have made the evolution of humans impossible. They divert large number of comets from hitting the earth. The spectacular collision of comet Shoemaker-Levy-9 with Jupiter, the astronomical event of July 1994, was an example of this mechanism in action.**

Also the anthropic principle has its most impressive successes when it predicts unknown observations. The most famous example stems from the study of stars. Carbon atoms, like all other atoms except hydrogen, helium and lithium, are formed in stars through fusion. While studying the mechanisms of fusion in 1953, the British astrophysicist Fred Hoyle*** found that carbon nuclei could not be formed from the alpha particles present inside stars at reasonable temperatures, except if they had an excited state with an increased cross section. From the fact of our existence, which is based on carbon, Hoyle thus predicted the existence of a previously unknown excited state of the carbon nucleus. Indeed, the excited state was found a few months later by Willy Fowler.****

Ref. 50

In its *serious* form, the anthropic principle is therefore the quest to deduce the description of nature from the experimental fact of our own existence. In the popular literature however, the anthropic principle is often changed, from a simple experimental method to deduce the patterns of nature, to its *perverted* form, a melting pot of absurd metaphysical ideas in which everybody mixes up his favourite beliefs. Most frequently, the experimental observation of our own existence has been perverted to reintroduce the idea of ‘design’, i.e. that the universe has been constructed with the aim to produce humans; often it is even suggested that the anthropic principle is an *explanation* – a gross example of disinformation.

Ref. 51

How can one distinguish between the serious and the perverted form? One gets exactly the same rules and patterns of nature if one would use as starting point the existence of pigs or of monkeys. In other words, if one would get *different* conclusions by using the *porcine principle* or the *simian principle*, one is using the perverted form, otherwise one is using the serious form. (The carbon-12 story is thus an example of the serious form.) This test is

* The most important instrument of a scientist is the waste basket.

** For a collection of pictures about this event, see e.g. the <http://garbo.uwasa.fi/pc/gifslevy.html> web site.

*** Fred Hoyle (1915, Bingley, Yorkshire–) English astrophysicist.

**** William A. Fowler (1911–), Nobel Prize winner in physics for this and related discoveries.

effective because there is no known pattern or ‘law’ of nature which is particular to humans but which is unnecessary for apes or for pigs.*

Er wunderte sich, daß den Katzen genau an den Stellen Löcher
in den Pelz geschnitten wären, wo sie Augen hätten.

Georg Christoph Lichtenberg**

Does one need cause and effect in explanations?

In nature there are neither rewards nor punishments
– there are consequences.

Ivan Illich (1926, Vienna –)

The world owes you nothing.

It was there first.

Mark Twain (1835–1910)

No matter how cruel and nasty and evil you may be,
every time you take a breath you make a flower happy.

Mort Sahl

Historically, the two terms have played an important role for philosophical discussions in the time when the ‘laws of nature’ have been formulated the first time with high precision, e.g. during the birth of modern mechanics. In those times, it was important to point out that every effect has a cause, in order to distinguish precise thought from thought based on beliefs such as ‘evolution from nothing’, ‘miracles’, or ‘divine surprises’. It was also essential to stress that effects are different from causes, to avoid pseudo-explanations such as the famous example by Molière where the doctor explains to his patient in elaborate terms that sleeping pills work because they contain a dormitive virtue.

Ref. 52

But in physics, the two concepts of cause and effect are not used at all. That miracles do not appear is expressed every time one uses symmetries and conservation theorems, and that cause and effect differ from each other is inherent in any evolution equation. Moreover, the concepts of cause and effect are not clearly defined; for example, it is especially difficult to define what is meant by one cause as opposed to several of them, and the same for one or several effects. Both terms are impossible to quantify and to measure. In other words, useful as ‘cause’ and ‘effect’ may be in personal life for distinction between events which regularly succeed each other, they are not necessary in physics. In physical explanations, they play no special roles.

* Apes though do not seem to be good physicists, as described in the text by D.J. POVINELLI, *Folk physics for apes: the chimpanzee’s theory of how the world works*, Oxford University Press 2000.

** ‘He was amazed that cats had holes cut into their fur precisely in those places where they had eyes.’ Georg Christoph Lichtenberg (1742–1799), German physicist and intellectual, professor in Göttingen, still famous today for his extremely numerous and witty aphorisms and satires. Among others, already in his time, Lichtenberg was making fun of all those who maintained that the universe was made exactly to the measure of man, a frequently encountered idea in the foggy world of the anthropic principle.

Is consciousness required?

Variatio delectat.*
Cicero

Ref. 53 A lot of mediocre discussions are going on about this topic, and we will avoid them here. What is consciousness? Most simply and concretely, *consciousness* means to possess a small part of oneself watching what the rest of oneself is perceiving, feeling, thinking, and doing. In short, consciousness is the ability to observe oneself, and especially one's inner mechanisms and motivations. For this reason, consciousness is *not* a prerequisite for studying motion. Indeed, animals, plants, machines are also able to observe motion. For the same reason, consciousness is obviously not necessary to observe quantum mechanical motion. On the other hand, both the study of motion and that of oneself have a lot in common: the need to observe carefully, to overcome preconceptions, to overcome fear, and the fun of doing so.

For the time being, we have put enough emphasis on the precision of concepts. Talking about motion is also something to be deeply enjoyed. Let us see why.

Precision and clarity obey the uncertainty relation:
their product is constant.

Curiosity

Precision is the child of curiosity.

Like in the history of every person, also in the history of mankind a long struggle took place to avoid the pitfalls of accepting as truth the statements of authorities, without checking the facts. Indeed, whenever curiosity leads somebody to formulate a question, there are always two general ways to proceed. One is to check the facts personally, the other is to ask somebody. But the last way is dangerous: it means to give up a part of oneself. Healthy people, children whose curiosity is still alive, as well as scientists, choose the first way. After all, science is adult curiosity.

Curiosity, also called the *exploratory drive*, plays strange games with people. Starting with the original experience of the world as a big 'soup' of interacting parts, curiosity can drive to find *all* the parts and *all* the interactions, as in this walk. And it drives not only people. It has been observed that when rats show curious behaviour, certain brain cells in the hypothalamus get active and secrete hormones which produce positive feelings and emotions. If a rat gets the possibility, via some implanted electrodes, to excite these same cells by pressing a switch, it does so voluntarily: rats get *addicted* to the feelings connected with curiosity. Like rats, humans are curious because they enjoy it. And they do so in at least four ways: because they are artists, because they are fond of pleasure, because they are adventurers, and because they are dreamers. Let us see how.

Ref. 54

At the origin, curiosity stems from the desire to interact in a positive way with the environment. Young children provide good examples: curiosity is a natural ingredient of their

* Change pleases.

life, in the same way that it is for other mammals and a few bird species; incidentally, the same taxonomic distribution one finds for play behaviour. In short, all animals who play are curious, and vice versa. Curiosity provides the basis for learning, for creativity, and thus e.g. for art. The artist and art theoretician Joseph Beuys (1920–1986) had as his own guiding principle that *every* creative act is a form of art. Humans, and especially children, enjoy curiosity because they feel its importance for creativity, and for growth in general.

Ref. 55

Curiosity regularly leads one to exclaim: ‘oh!’, an experience that leads to the second reason to be curious: relishing feelings of wonder and surprise. Epicurus (Epikuros) (341–271 BCE) maintained that this feeling, *φραυμάξειν*, is the origin of philosophy. These feelings, which today are variously called religious, spiritual, numinous, etc., are the same to which rats can get addicted. Among them, Rudolf Otto has introduced the now classical distinction into the fascinating and the frightening. He named the corresponding experiences ‘mysterium fascinans’ and ‘mysterium tremendum.’* In this division, physicists, the other scientists, children, and other connoisseurs take a clear stand: they choose the fascinans as starting point for their actions and for their approach to the world. Such feelings of fascination induce some of the children who look at the night sky to dream about becoming astronomers, some of those who look through the microscope to become biologists or physicists, and so forth. (It could also be that genetics plays a role in this pleasure of novelty seeking.)

Ref. 56

Perhaps the most beautiful moments in the study of physics are those appearing after new observations have shaken one’s previously held thinking habits, have forced to give up a previously held conviction, and have engendered the feeling of being lost. When, in this moment of crisis, one finally discovers the more adequate, more precise description of the observations providing a better insight into the world around or inside oneself, one is pervaded of a feeling usually called illumination. Whoever has kept alive the memory and the taste for these magic moments knows that in those situations one is pervaded by a feeling of union between oneself and the world.** The pleasure of these moments, the adventures of the change of thought structures connected with them, and the joy of insight following them provides the drive for many scientists. Little talking and lots of pleasure is their common denominator. In this spirit the Austrian born physicist Viktor Weisskopf likes to say jokingly: ‘There are two things that make life worth living: Mozart and quantum mechanics.’

The choice away from the tremendum towards the fascinans stems from an innate desire, most obvious in children, to reduce uncertainty and fear. This drive is the father of all adventures. It has a well-known parallel in ancient Greece, where the first men studying observations, such as Epicurus, stated explicitly that their aim was to free people from unnecessary fear, and to deepen knowledge with the aim to transform people from frightened

* This distinction is the basis of RUDOLF OTTO, *Das Heilige – Über das Irrationale in der Idee des Göttlichen und sein Verhältnis zum Rationalen*, Beck, München, 1991. This is a new edition of the epoch-making work originally published at the beginning of the twentieth century. Rudolf Otto (1869–1937) was one of the most important theologians of his time.

** Several researchers have studied the situations leading to these magic moments in more detail, notably the Prussian physician and physicist Hermann von Helmholtz (1821–1894) and the French mathematician Henri Poincaré (1854–1912). They distinguish four stages in the conception of an idea at the basis of such a magic moment: saturation, incubation, illumination, and verification.

Ref. 57

passive victims into fascinated, active and responsible beings. Those ancient thinkers started to popularize the idea that like the common events in our life, also the more rare events follow rules. For example, Epicurus underlines that lightning is a natural phenomenon due to interactions between clouds, and stressed that it is a natural process, i.e. a process following rules, in the same way as does the falling of a stone or any more familiar process of everyday life.

Investigating the phenomena around them, philosophers, and later on scientists, succeeded to free humans from most of their fear due to uncertainty and to the lack of knowledge about nature. This liberation played an important role in the history of human culture and still does so in the personal history of many scientists. The aim to arrive at stable, rock-bottom truths has both inspired (but also hindered) many of them; Albert Einstein is a well-known example for both, discovering relativity, helping to start up but then denying quantum mechanics.

In the experience and in the development of every human being, curiosity, and therefore the sciences, come *before* the two domains of magic and superstition. The former needs deceit to be effective, and the latter needs indoctrination; curiosity doesn't need either. Conflicts with superstitions, ideologies, authorities, or the rest of society are preprogrammed.

Curiosity is the exploration of limits. There are two possibilities: the limit can turn out to be real or apparent. If the limit is real, the most productive attitude is that of acceptance. Approaching the limit then gives strength. If the limit is only apparent and in fact non-existing, the best attitude is that of reevaluating the mistaken view, extracting the positive role it performed, and then to cross it. Distinguishing between the two is only possible when the limit is investigated with great care. That is the quest for precision. Distinguishing between the two also requires openness and unintentionality. The lack of the latter is often a hindrance for progress.

Das gelüftete Geheimnis rächt sich.*
Bert Hellinger (1925–)

Courage

It is dangerous to be right in matters on which
the established authorities are wrong.
Voltaire (1694–1778)

Manche suchen Sicherheit, wo Mut gefragt ist,
und suchen Freiheit, wo das Richtige keine Wahl läßt.**
Bert Hellinger (1925–)

Ref. 63 In the adventure to get to the top of motion mountain, most of the material in this intermezzo is necessary. But we need more. Like any enterprise, also curiosity requires courage, and

* The unveiled secret takes revenge.

** 'Some look for security where courage is required and look for freedom where the right way doesn't leave any choice.' This is from the beautiful booklet by BERT HELLINGER, *Verdichtetes*, Carl-Auer Systeme Verlag, 1996.

complete curiosity, as aimed for in our quest, requires complete courage. In fact, it is easy to get discouraged from this trip. It is often dismissed by others as useless, uninteresting, childish, confusing, damaging or even evil. Indeed, between the death of Socrates in 399 BCE and Paul Thierry, Baron d'Holbach, in the 18th century, there are no books with the statement 'gods do not exist', because of the life threats suffered by those who dared to make it.

Through the constant elimination of uncertainty, both curiosity and scientific activity are implicitly opposed to any idea, person or organization which tries to avoid the comparison of statements with observations. As mentioned above, this implies living with superstitions or beliefs. Through the refusal inherent in them, superstitions and beliefs produce fear. Fear is the basis of all unjust authorities. As a consequence, curiosity and science are fundamentally opposed to unjust authority, a connection that has made life difficult for people such as Anaxagoras (500–428 BCE) in ancient Greece, Hypatia in the christian Roman empire, Galileo Galilei in the church state, Antoine Lavoisier in France, Albert Einstein in Germany; in the second half of the twentieth century victims were Robert Oppenheimer and Chandler Davis in the United States, and Andrei Sakharov in the Soviet Union. Each of them has a horrible but instructive story to tell, as have, more recently, Fang Lizhi, Xu Liangying, Liu Gang and Wang Juntao in China, Kim Song-Man in South Korea, Otanazar Aripov in Uzbekistan, Ramadan al-Hadi al-Hush in Libya, Bo Bo Htun in Burma, as well as many hundreds of others; in many authoritarian societies the antagonism between curiosity and injustice has hindered or even suppressed completely the development of physics and the other sciences, with extremely negative economic, social and cultural consequences.

When embarking on this ascent, we need to be conscious of what we are doing. In fact, external obstacles are not the only ones. They can be avoided or at least largely reduced by keeping the project secret. Other difficulties still remain, this time of personal nature. Many tried to embark in this adventure with some hidden or explicit intention, usually of ideological nature, and then got tangled up by it before reaching the end. Some were not prepared to the humility required for such an endeavour. Others were not prepared for the openness required, which can shatter deeply held beliefs. Still others were not ready to continually turn towards the unclear, the dark and the unknown, confronting it at every occasion.

On the other hand, the dangers are worth it. By taking curiosity as a maxim, facing disinformation and fear with all courage, one achieves freedom from all beliefs. In exchange, one gets to savour the fullest pleasures and the deepest satisfaction that life has to offer.

After this look to the basics, we continue our hike. The trail towards the top of motion mountain leads us towards the next adventure: discovering the origin of sizes and shapes in nature.

And the gods said to man:
 'Take what you want,
 and pay the price.'
 (Popular saying)

It is difficult to make a man miserable
 while he feels he is worthy of himself.

Abraham Lincoln (1809–1865) US President



References

- 1 See for example the text by ... *Evolution*, ... See also STEPHEN J. GOULD, 1980, *The Panda's thumb*, W.W. Norton & Co., New York. One of the several interesting and informative books on evolutionary biology by the best writer in the field. The epochal work by CHARLES DARWIN, *On the origin of species*, can be found on the web nowadays, e.g. on the <http://entisoft.earthlink.net/origspec.htm> web site. Cited on page 415.
- 2 A simple description is *Woher kommt der Mensch*, Belsler Verlag, ... Cited on page 415.
- 3 There is disagreement among experts about the precise timing of this experience. Some say that only birth itself is that moment. However, there are several standard methods to recall memories of early life, even of the time before birth; one is described and used by J.K. STETTbacher, *Making sense of suffering*, Penguin, New York, 1991, translated from the German original. Even more impressive examples are given by N.J. MAYER, *Der Kainkomplex – neue Wege der systemischen Familientherapie*, Integral Verlag, 1998. Cited on page 415.
- 4 SANJIDA O'CONNELL, *Mindreading – how we learn to love and lie*, Arrow, 1998. This interesting book describes the importance of lying in the development of a human being, and explains the troubles those people have who cannot read other minds and thus cannot lie, such as autistics. Cited on page 416, 444.
- 5 The approach to describe observations as related parts is called structuralism; the starting point for this movement was de Saussure's *Cours de linguistique générale*, (see the footnote on page 425). A number of thinkers have tried to use the same approach in philosophy, mythology, and literature theory, with little success, however. An overview of the (modest) success of structuralism in linguistics and its failure in other fields is given by L. JACKSON, *The poverty of structuralism: literature and structuralist theory*, Longman, 1991. The author argues that when one reduces systems to interacting parts, one neglects the specific content and properties of the elements of the system, and this approach prevents a full understanding of the system under discussion. Cited on page 418.
- 6 For a view of the mental abilities different from that of Piaget (described on page 418), a presently much discussed author is the soviet experimental psychologist Lev Vigotsky, whose pathbreaking ideas and complicated life are described e.g. in LEV VIGOTSKY, *Mind in Society*, Harvard University Press, 1978, or in RENE VAN DER VEER & JAAN VALSINER, *Understanding Vygotsky: a quest for synthesis*, Blackwell Publishers, 1994. More extensive material can be found in the extensive work by RENÉ VAN DER VEER & JAAN VALSINGER, *The Vygotsky Reader*, Blackwell, 1994. Cited on page 418.
- 7 A somewhat unconventional source for more details is the beautiful text by BRUNO BETTELHEIM, *The uses of enchantment: the meaning and importance of fairy tales*, Knopf, 1976. Cited on page 418.
- 8 Quoted in V. HARLEN, R. RAPPMANN & P. SCHATA, *Soziale Plastik – Materialien zu Joseph Beuys*, Achberger Verlag, 1984, on p. 61. Cited on page 419.
- 9 The problems one has when one loses the ability to classify or to memorize are told in the beautiful book by the neurologist OLIVER SACKS, *The man who mistook his wife for a hat*, Picador, 1985, which collects many case studies he encountered in his work. More astonishing

- cases are collected in his equally impressive text *An anthropologist on Mars*, Picador, 1995.
- See also the beautiful text DONALD D. HOFFMAN, *Visual intelligence – how we create what we see*, W.W. Norton & Co., 1998, and its associated ari.ss.uci.edu/cogsci/personnel/hoffman.html web site. Cited on page 419, 421.
- 10 For a passionate introduction into the connections between language and the brain from a Chomskian perspective, see the bestselling book by STEVEN PINKER, *The language instinct – How the mind creates language*, Harper Perennial, 1994. The green idea sentence is discussed in a chapter of the book. Cited on page 419, 448, 462.
 - 11 An overview of the status of the research into the origin of bipedalism is given by BERNARD WOOD, *Four legs good, two legs better*, Nature **363**, pp. 587–588, 17 June 1983. Cited on page 419.
 - 12 More about the connection between entropy and computers can be found in the classic paper by R. LANDAUER, ..., IBM Journal of Research and Development **5**, p. 183, 1961, and in C.H. BENNETT & R. LANDAUER, ..., Scientific American **235**, pp. 48–56, 1985. Cited on page 422.
 - 13 W.H. ZUREK, *Thermodynamic cost of computation, algorithmic complexity and the information metric*, Nature **341**, pp. 119–124, 14 August 1989. Cited on page 422.
 - 14 J.J. Hopfield/ Nature **376**, pp. 33–36, 1995. This paper by one of the fathers of the field presents one possibility by which the *timing* of nerve signals, instead of the usually assumed firing frequency, could also carry information. Cited on page 423.
 - 15 The details of the properties of the firing patterns of neurons are nicely described in the article by M. MAHOWALD & R. DOUGLAS, *A silicon neuron*, Nature **354**, pp. 515–518, 19/26 December 1991, in which they show how one can simulate a neuron's electrical behaviour using a silicon circuit. Cited on page 423.
 - 16 The discussion whether the brain is or is not superior to a computer is nicely summarized by G. VOLLMER, *Algorithmen, Gehirne, Computer – Was sie können und was sie nicht können, Teil I und Teil II*, Naturwissenschaften **78**, p. 481, 1991, **78**, pp. 533–542, 1991. Cited on page 424.
 - 17 However, the language with the largest available dictionary is Dutch, with the 40 volumes of the *Wordenboek der Nederlandsche Taal*, which appeared between 1864 and 1998. It has almost 400 000 entries. Cited on page 426.
 - 18 The list and the remark on discovery on concepts is due to a personal communication from Anna Wierzbicka. An older list is published in her book *Semantics, primes, and universals*, Oxford University Press, 1996. Cited on page 426, 442.
 - 19 W.S. HATCHER, *Foundations of mathematics*, W.B. Saunders Co., Philadelphia, 1968. There is also the article by PAUL J. COHEN & REUBEN HERSCH, *Non-cantorian set theory*, Scientific American **217**, pp. 104–116, 1967. Cohen was the mathematician who in 1963 proved that the negation of the continuum hypothesis could be added to the axioms of set theory and still produce a consistent theory; he calls such sets *non-cantorian*. Cited on page 430.
 - 20 See the beautiful article by IAN STEWART, *Fair shares for all*, New Scientist pp. 42–46, 17 June 1995. Cited on page 430.
 - 21 RUDY RUCKER, *Infinity and the mind – the science and philosophy of the infinite*, Bantam, Toronto, 1983. Cited on page 432.
 - 22 This general division of mathematics is nicely explained in the text by PIERRE BASIEUX, *Die Architektur der Mathematik – Denken in Strukturen*, Rororo, 2000. Cited on page 433.
 - 23 The issue is treated in his *Summa Theologica*, in question 52 of the first part. The complete text, several thousand pages, can be found on the <http://www.knight.org/advent> web site. We come back to it in the part on quantum theory, in the section on the Pauli exclusion principle. It seems

See page 531

- that the whole question goes back to the *Liber Sententiarum*, by Peter the Lombard. Cited on page 435.
- 24 IAN STEWART, *Daisy, daisy, give me your answer, do*, Scientific American pp. 76–79, January 1995. This pedagogical article explains how the growth of plants usually leads to flowers whose number of petals is from the Fibonacci series 1, 1, 2, 3, 5, 8, 13, 21, 34, 55, 89, 144, etc. Deviations from this ideal case are also explained. The original work are two articles by S. DOUADY & Y. COUDER, *La physique des spirales végétales*, La Recherche **24**, pp. 26–36, 1993, and *Phyllotaxis as a self-organized growth process*, in *Growth patterns in physical sciences and biology*, edited by J.M. GARCIA-RUIZ & al., Plenum Press, 1993. Cited on page 435.
- 25 H. DAVSON, *The Eye*, Academic Press, 1962. Cited on page 435.
- 26 See the <http://akbar.marlboro.edu/mahoney/cube/NxN.txt> web site. Cited on page 435.
- 27 An introduction to the surreal numbers is given by the article by POLLY SHULMAN, *Infinity plus one, and other surreal numbers*, Discover pp. 99–105, December 1995. There is also the text by D. KNUTH, *Surreal numbers: how two ex-students turned on to pure mathematics and found total happiness*, Addison Wesley, 1974, also available on the <http://www-cs-faculty.stanford.edu/knuth/sn.html> web site. The usually quoted references on the topic include JOHN H. CONWAY, *On numbers and games*, Academic Press, 1976, E.R. BERLEKAMP, J.H. CONWAY & R.K. GUY, *Winning ways for your mathematical plays, volume I: games in general*, Academic Press, 1972, and H. GONSHOR, *An introduction to surreal numbers*, Cambridge University Press, 1986. Cited on page 436, 438.
- 28 This beautiful little problem is discussed by IAN STEWART, *A bundling fool beats the wrap*, Scientific American, pp. 109–111, June 1993. The answer, in Japanese, is go-ju-nana. The four-dimensional answer is known to lie somewhere between 50 000 and 100 000, whereas the five-dimensional answer is conjectured to be ‘never’. Cited on page 438.
- 29 A. PAIS, *Niels Bohr's times: in physics, philosophy, and polity*, Oxford University Press, 1991, page 176. Cited on page 438.
- 30 EUGENE WIGNER, *Symmetries and reflections*, Indiana University Press, 1962. Cited on page 438.
- 31 About the different aspects of falsifiability of general statements it is commonplace to cite the work by the epistemologist Karl Popper (1902–1994), especially his long and boring book *Logik der Forschung*, first published in 1934. The reason for this boredom is that Popper's work is just Pierre Duhem's warmed up. Cited on page 445.
- 32 About a good way of making blood that liquefies, see L. GARLASCHELLI, F. RAMACCINI & S. DELLA SCALA, *Working bloody miracles*, Nature **353**, p. 507, 1991. The milk drinking Indian statues were common around the world in 1994–1995. About healers, see JAMES RANDI, *Flim-flam!*, Prometheus Books, Buffalo, New York, 1987, and the exquisite book by H.C. ZANDER, *Warum ich Jesus nicht leiden kann*, Rowohlt, 1994. Cited on page 446.
- 33 For an opinion completely contrary to the one described here, see the book by GREGORY J. CHAITIN, *The limits of mathematics*, Springer Verlag, 1997, also to be found at the <http://www.cs.auckland.ac.nz/CDMTCS/chaitin/lm.html> web site, as well as his other works. Chaitin has devoted most of his life to the questions discussed in the section, especially on computability. Cited on page 448.
- 34 See the book by J. BARWISE & J. ETCHEMENDY, *The liar*, Oxford University Press, New York, 1987. Cited on page 448.
- 35 This definition (statement 4.11) and many other statements about science are in the beautiful and rightly famous text by LUDWIG WITTGENSTEIN, *Tractatus logico-philosophicus*, Edition Suhrkamp, 1963. It gives a condensed summary of the basis of science, thought and language in a collection of highly structured and numbered sentences. Cited on page 449, 453.

- 36 Cited by MAX DRESDEN, *The Klopsteg memorial lecture*, American Journal of Physics **66**, pp. 468–482, 1998. Cited on page 449.
- 37 Well-known books are e.g. FRIEDRICH KOHLRAUSCH, *Praktische Physik*, Teubner, 24. Auflage, 1996. Cited on page 450.
- 38 Results are described e.g. in L. BERGMANN & C. SCHÄFER, *Lehrbuch der Experimentalphysik*, Band I, II, III und IV, W. de Gruyter. Cited on page 450.
- 39 LANDOLT-BÖRNSTEIN, edited by K.-H. HELLWEGE & O. MADELUNG, *Zahlenwerte und Funktionen aus Naturwissenschaften und Technik*, Neue Serie, Springer-Verlag, Berlin, 1984. This series of more than one hundred volumes contains all important observations in the domain of physics. Cited on page 450.
- 40 The strange and sometimes dangerous consequences of beliefs can be found e.g. in MARTIN GARDNER, *Fads and Fallacies*, Dover, 1957, and in JAMES RANDI, *Faith healers*, Prometheus Books, 1989. The million dollar prize for showing any paranormal or supernatural effect is available from his <http://www.randi.org> web site. Cited on page 455.
- 41 See the nice collection of cranks on the www.crank.net web site. Cited on page 455.
- 42 As an example, the opposite view on the emergence of properties is strongly defended by ...in Physics Today 1998. Cited on page 456.
- 43 See page 133 of the bibliography by JOHN BOWLBY, *Charles Darwin*, Pimlico, 1991. Cited on page 456.
- 44 JOHN HORGAN, *The end of science – Facing the limits of knowledge in the twilight of scientific age*, Addison Wesley, 1996. Cited on page 460.
- 45 A beautiful introduction into Greek philosophy is EDUARD ZELLER, *Outlines of the history of Greek philosophy*, Dover, 1980, a reprint of a book published in 1928. Among others, it gives a clear exposition of the philosophy of Democritus and the other presocratics. Cited on page 460.
- 46 The famous quote is found at the beginning of chapter XI, ‘The Physical Universe’, in ARTHUR EDDINGTON, *The Philosophy of Physical Science*, Cambridge, 1939. Cited on page 461.
- 47 GIUSEPPE FUMAGALLI, *Chi l’ha detto?*, Hoepli, Milano, 1983. Cited on page 462.
- 48 For a beautiful text on fractals, see the footnote on page 47. Cited on page 464.
- 49 As has been pointed out by René Descartes. Cited on page 466.
- 50 The famous carbon ¹²C resonance was found by Willy Fowler, as described in E.M. BURBRIDGE, G.R. BURBRIDGE, W.A. FOWLER & F. HOYLE, ..., *Reviews of Modern Physics* **29**, pp. 547–560, 1957. Cited on page 468.
- 51 An extensive overview of the topic is given by JOHN D. BARROW & FRANK J. TIPLER, *The anthropic cosmological principle*, Oxford University Press, 1986. The term itself is due to Brandon Carter, who coined it in 1973 and presented it on a symposium devoted to the 500th anniversary of Nicolaus Copernicus. For more literature, see YURI I. BALASHOV, *Resource Letter AP-1: the anthropic principle*, American Journal of Physics **59**, pp. 1069–1076, 1991. Cited on page 468.
- 52 VOLTAIRE, *Candide ou l’optimisme*, 1759. See the footnote on page 121. The book is so good that it was still seized by the US customs in 1930, and the US post office refused to transport it as late as 1944. For more details, search for ‘banned books online’ on the world-wide web. Cited on page 469.
- 53 The number of books on consciousness is large and the contents not always interesting, such as JOHN ECCLES &, ..., Cited on page 470.
- 54 See e.g. the *Encyclopedia Britannica*, Macropaedia, in the entry on animal behaviour. Cited on page 470.

- 55** A straight and informative introduction to the work and ideas of Joseph Beuys (in German) is by RENATE GEORGI, *Joseph Beuys*, RAAbits Kunst, Raabe Fachverlag, September 1996. Cited on page [471](#).
- 56** Two studies, one by R.P. EPSTEIN, in *Nature Genetics ...*, January 1996, and another by J. BENJAMIN, found that people with a special form of the D4 dopamine receptor gene, or D4DR, are more prone to novelty seeking than people with the usual form. The D4DR gene regulates the formation of dopamine receptors, a chemical messenger in the brain which has been a candidate for some time for a substance involved in the propensity for novelty seeking. Cited on page [471](#).
- 57** More can be found in JACQUES HADAMARD, *The mathematician's mind – The psychology of invention in the mathematical field*, Princeton Science Library, 1996. Cited on page [471](#).
- 58** For an exploration of 'inner' motions, see the beautiful text by RICHARD SCHWARTZ, *Internal Family Systems Therapy*, The Guilford Press, 1995. Cited on page .
- 59** A clear overview of philosophy of science, often called epistemology, without unnecessary detail, is given by ... BLANCHÉ, ..., Presses Universitaires de France, 1996. Cited on page .
- 60** An introduction to neurology ... Cited on page .
- 61** An introduction to computer science ... Cited on page .
- 62** ALFRED TARSKI, *Introduction to modern logic*, Dover, 1996. See also LEWIS CARROLL, *Alice in wonderland*, ... Cited on page .
- 63** For example, one needs the courage to face envy. About this topic see the classic text by HELMUT SCHOECK, *Der Neid*, 1996, the standard work in the field. Cited on page [472](#).



Second Part

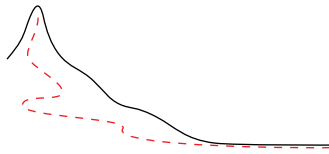

QUANTUM THEORY

WHAT IS MATTER? WHAT ARE INTERACTIONS?

Where the existence of a minimal amount of change is deduced,
implying that motion is fuzzy,
that matter is not permanent,
that boxes are never tight,
that matter is composed of elementary units
and that light and interactions are streams of particles,
thus explaining why antimatter exists,
why the floor does not fall but keeps on carrying us,
why particles are unlike condoms,
why empty space pulls mirrors together
and why the stars shine.



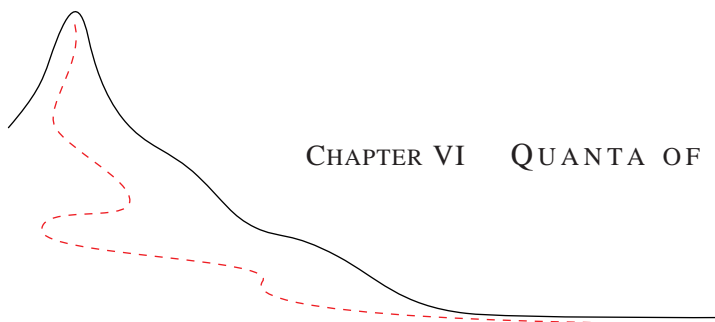

CHAPTER VI QUANTA OF LIGHT AND MATTER

16. An appetizer – quantum theory for lawyers

Ref. 1

Natura [in operationibus suis] non facit saltus.*
15th century

Escalating motion mountain up to this point, we have completed three main legs. We first encountered Galileo's mechanics, the description of motion for kids, then Einstein's relativity, the description of motion for science fiction enthusiasts, and finally Maxwell's electrodynamics, the description of motion valuable to craftsmen and businessmen.

These three classical descriptions of motion are impressive, beautiful, and useful. However, they also have a small problem: they are wrong. The reason is simple: none of them describes *life*. When we observe a flower, enjoying its bright colours, its wild smell, its soft and delicate shape, or the fine details of its symmetry, none of the three classical descriptions can explain what is going on. In particular, neither the properties of the flower nor the working of our senses are explained. Classical physics can partly describe them, but it cannot explain their origins. For an explanation, we need *quantum theory*. In fact we will discover that *every type of pleasure* in life is an example of quantum motion. Just try; take any example of a pleasant situation, such as a beautiful evening sky, a waterfall, a caress, or a happy child. Classical physics is not able to explain it.

Challenge 1067

See page 159

In the beginning of physics this limitation was not seen as a shortcoming: in those times neither senses nor material properties were known to be related to motion. And of course, in older times the study of pleasure was not deemed a serious topic of investigation for a respectable researcher. However, we already learned that the senses of touch, smell and sight are first of all *detectors of motion*. Without motion, no senses! In addition, all detectors are built of matter. In the chapter on electromagnetism we started to understand that all

* Nature [in its workings] makes no jumps.

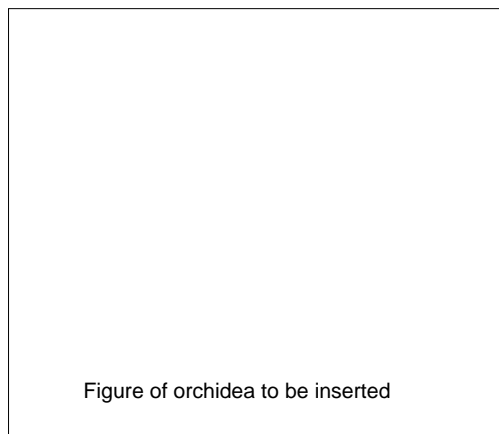

Figure 177 An example of a quantum system

Figure 177 An example of a quantum system. Just try; take any example of a pleasant situation, such as a beautiful evening sky, a waterfall, a caress, or a happy child.

properties of matter are due to motion of charged constituents. Density, stiffness, colour and all other material properties result from the electromagnetic behaviour of the Lego bricks of matter, namely the molecules, the atoms, and the electrons. Thus, also matter properties are consequences of motion. In addition, we saw that these tiny constituents are *not* correctly described by classical electrodynamics. We even found that light itself behaves unclassically. Therefore the inability of classical physics to describe matter and the senses is indeed due to its intrinsic limitations.

See page 398

In fact, every failure of classical physics can be traced back to a single, fundamental discovery made in 1899 by Max Planck: *

Ref. 2

▷ *In nature, actions smaller than the value $\hbar/2 = 0.53 \cdot 10^{-34}$ Js are not observed.*

All experiments trying to do so invariably fail. In other words, in nature there is always some action – like in a good movie. This existence of a minimal action, the *quantum principle*, is in *full* contrast with classical physics. (Why?) However, it has passed the largest imaginable number of experimental confirmations, many of which we will encounter in this second part of our mountain ascent. Planck discovered the principle when studying the properties of incandescent light, i.e. the light emanating from hot bodies. But the quantum principle also applies to motion of matter, and even, as we will see later, to motion of space-time. By the way, the factor 1/2 results from the historical accidents in the definition of the constant \hbar , which is read as ‘eitch-bar’. Despite the missing factor, the constant \hbar is called the *quantum of action* or also, after its discoverer, (*reduced*) *Planck’s constant*.

Challenge 1084

See page 398

The quantum principle states that no experiment whatsoever can measure an action value smaller than $\hbar/2$. For a long time, even Einstein tried to devise experiments to overcome the limit. But he failed: nature does not allow it.

Interestingly, since action in physics, like action in the movie industry, is a way to measure the *change* occurring in a system, a minimum action implies that *there is a minimum change in nature*. The quantum of action thus would be better named the *quantum of change*. Whatever one observes, there always is change. Before we cite all the experiments confirming this statement, we give an introduction to some of its more surprising consequences.

Since action measures change, a minimum observable action means that two subsequent observations of the same system always differ by at least $\hbar/2$. In every system, there is always *something* happening. As a consequence, in nature *there is no rest*. *Natura facit saltus*. Everything moves, all the time, at least a little bit. True, it is only a tiny bit, as the value of $\hbar/2$ is so small. For example, the quantum of action implies that in a mountain, a system at rest if there is any, all atoms and all electrons are continuously buzzing around. Rest can be observed only macroscopically, and only as a long time or many particle average.

See page 480

Since there is a minimum action for all observers, and since there is no rest, in nature *there is no perfectly straight and no perfectly uniform motion*. Forget all you have learned so far. Every object moves in straight and uniform motion only approximately, and only when observed over long distances or long times. We will see later that the more massive

* This somewhat unconventional, but useful didactic approach is almost never found in the literature and used in a teaching text for the first time here. Ref. 3

About Max Planck and his accomplishments, see the footnote on page 398. In fact, the cited quantum principle is a simplification; the constant originally introduced by Planck was the (unreduced) constant $h = 2\pi\hbar$. The factors 2π and $1/2$ leading to the final quantum principle were found somewhat later, by other researchers.

Challenge 1101 the object is, the better is the approximation. Can you confirm this? As a consequence, macroscopic observers can still talk about space-time symmetries. *Special* relativity can thus be reconciled with quantum theory.

Obviously, also free fall, i.e. motion along geodesics, exists only as a long time average. In this sense, *general* relativity, being based on the existence of freely falling observers, cannot be correct when actions of the order of \hbar are involved. Indeed, the reconciliation of the quantum principle with *general* relativity and thus with curved space is a big challenge. The issues are so mind-shattering that the topic forms a separate, third part of this mountain ascent.

Have you ever wondered why leaves are green? Probably you know that they are green because they absorb blue light, of small wavelength, and red light, of large wavelength, and let green, medium wavelength light undisturbed. How can a system filter out the small and the large, and let the middle go through? To do so, leaves must somehow *measure* the wavelength. But we have seen that classical physics does not allow to measure length or time intervals, as any measurement requires a measurement unit, and classical physics does not allow to define units for them. On the other hand, it takes only a few lines to confirm that with help of the quantum of action \hbar (and the Boltzmann constant k , which Planck discovered at the same time), fundamental measurement units of *all* measurable quantities can be defined, including length and thus wavelength. Can you find a combination of c , G and \hbar giving a length? It only will take a few minutes. When Planck found the combination, he was happy like a child; he knew straight away that he had made a fundamental discovery, even though in 1899 quantum theory did not exist yet. He even told his seven year old son Erwin about it, while walking with him through the forests around Berlin. Planck knew that he had found the key to understand most of the effects which were unexplained so far. In particular, without the quantum of action, colours would not exist. Every colour is a quantum effect.*

Challenge 1118

Planck realized that the quantum of action allows to understand the *size* of all things. With the quantum of action, it was finally possible to answer the question on the maximum size of mountains, of trees, and of humans. Planck knew this, as the quantum of action confirmed the answer Galileo had deduced already long before him: size are due to fundamental, minimal scales in nature. The way the quantum of action alone allows to understand the sizes of physical systems will be uncovered step by step in the following pages.

See page 143

For example, it turns out that the size of things are related to the size of atoms; however, the *size of atoms* is a *direct consequence* of the quantum of action. Can you deduce an approximation for the size of atoms, knowing that it is given by the motion of electrons of mass m_e and charge e , constrained by the quantum of action? This formula was discovered in 1910 by A.E. Haas, 15 years before quantum theory was formulated; at the time, everybody made fun of him. Nowadays, the expression is found in all textbooks.

Challenge 31

Thus the quantum of action has the important consequence that Gulliver's travels are impossible. There are no tiny people and no giant ones. Classically, nothing speaks against the idea; but the quantum of action does. Can you provide the detailed argument?

Challenge 48

But if rest does not exist, how can *shapes* exist? Any shape, also that of a flower, is the result of body parts remaining *at rest* with respect to each other. Now, all shapes result from

Challenge 14

* It is also possible to define all units using c , G , and e , the electron charge. Why is this not satisfactory?

the interactions of matter constituents, as shown most clearly in the shape of molecules. But how can a molecule, such as the water molecule H_2O , have a shape? In fact, it does not have a *fixed* shape, but its shape fluctuates, as expected from the quantum of action. Despite the fluctuations it does have an *average* shape, because different angles and distances correspond to different energies. And again, these average length and angle values only result because the quantum of action leads to fundamental length scales in nature. Without the quantum of action, there would be *no* shapes in nature.

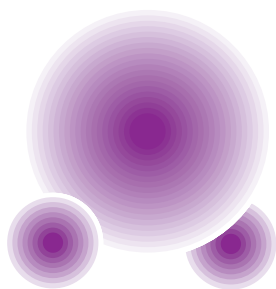

Figure 178 An (average) water particle

As we will discover shortly, quantum effects surround us from all sides. However, since the minimum action is so small, its effects *on motion* appear mostly, but not exclusively, in *microscopic* systems. The study of such systems has been called *quantum mechanics* by Max Born, one of the main figures of the field.* Later on, the term *quantum theory* became more popular. In any case, quantum physics is the description of microscopic motion. But when is quantum theory necessary? Table 42 shows that all processes on atomic and molecular scale, including biological and chemical ones, involve action values near the quantum of action. So do processes of light emission and absorption. All these phenomena can be described *only* with quantum theory.

The term ‘quantum’ theory, by the way, does not mean that all measurement values are *multiples* of a smallest one; this is correct only in certain cases. Quantum theory means the existence of *minimum* measurable values, precisely in the way that Galileo already speculated about in the 17th century. As mentioned in detail earlier on, it was Galileo’s insistence on these ‘piccolissimi quanti’ that got him condemned to lifelong imprisonment, and not, as is usually told, his ideas on the motion of the earth. Of course, we will discover that only the idea of a smallest change leads to a precise and accurate description of nature.

Table 42 also shows that the term ‘microscopic’ has a different meaning for a physicist and for a biologist. For a biologist, a system is microscopic if it requires a *microscope* for its observation. For a physicist however, a system is microscopic if its characteristic action is of the order of the quantum of action. In short, for a physicist, a system is microscopic if it is *not* visible in a (light) microscope. To increase the confusion, some quantum physicists nowadays call their own class of microscopic systems ‘mesoscopic,’ whereas many classical, macroscopic systems are now called ‘nanoscopic’. Both names mainly help to attract funding.

Ref. 4 * Max Born (1882, Breslau–1970) first studied mathematics, then turned to physics. Professor in Göttingen, he made the city one of the world centres of physics. He developed quantum mechanics with his assistants Werner Heisenberg and Pascual Jordan, then applied it to scattering, to solid state physics, to optics, and to liquids. He was the physicist who first understood that the state function describes a probability amplitude. He is one of the authors of the famous Born & Wolf textbook on optics; still now it is the main book of the field. He attracted to Göttingen the most brilliant talents of the time, receiving as visitors Hund, Pauli, Nordheim, Oppenheimer, Goepfert-Mayer, Condon, Pauling, Fock, Frenkel, Tamm, Dirac, Mott, Klein, Heitler, London, von Neumann, Teller, Wigner, and dozens of others. Jewish, Max Born lost his job in 1933; he emigrated and became professor in Edinburgh, where he stayed for twenty years. Physics at Göttingen university never recovered from this loss. For his elucidation of the meaning of the wave function he received the 1954 Nobel prize in physics.

See page 142

System & change	typical action	motion type
<i>Light</i>		
Smallest amount of light absorbed by a coloured surface	$1 \hbar$	quantum
Smallest hit when light reflects from mirror	$2 \hbar$	quantum
Smallest visible amount of light	ca. $5 \hbar$	quantum
Smallest amount of light absorbed in flower petal	ca. $1 \hbar$	quantum
Blackening of photographic film	ca. $3 \hbar$	quantum
Photographic flash	ca. $10^{17} \hbar$	classical
<i>Electricity</i>		
Electron ejected from atom	ca. $1 - 2 \hbar$	quantum
Electron added to molecule	ca. $1 - 2 \hbar$	quantum
Electron extracted from metal	ca. $1 - 2 \hbar$	quantum
Signal transport in nerves, from one molecule to the next	ca. $5 \hbar$	quantum
Current flow in lighting bolt	ca. $10^{38} \hbar$	classical
<i>Material science</i>		
Tearing apart two neighbouring iron atoms	ca. $1 - 2 \hbar$	quantum
Breaking a steel bar	ca. $10^{35} \hbar$	classical
Basic process in superconductivity	$1 \hbar$	quantum
Basic process in transistors	$1 \hbar$	quantum
Basic process in magnetic effects	$1 \hbar$	quantum
<i>Chemistry</i>		
Atom collisions in liquids at room temperature	ca. $1 \hbar$	quantum
Shape oscillation of water molecule	ca. $1 - 5 \hbar$	quantum
Shape change of molecule, e.g. in chemical reaction	ca. $1 - 5 \hbar$	quantum
Single chemical reaction curling a hair	ca. $2 - 6 \hbar$	quantum
Tearing apart two mozzarella molecules	ca. $300 \hbar$	quantum
Smelling one molecule	ca. $10 \hbar$	quantum
Burning fuel in a cylinder in an average car engine explosion	ca. $10^{37} \hbar$	classical
<i>Life</i>		
Air molecule hitting ear drum	ca. $2 \hbar$	quantum
Smallest sound signal detectable by the ear	challenge	classical
DNA duplication step in cell division	ca. $100 \hbar$	quantum
Ovule fecundation	ca. $10^{14} \hbar$	classical
Smallest step in molecular motor	ca. $5 \hbar$	quantum
Sperm motion by one cell length	ca. $10^{15} \hbar$	classical
Cell division	ca. $10^{19} \hbar$	classical
Fruit fly's wing beat	ca. $10^{24} \hbar$	classical
Person walking one body length	ca. $2 \cdot 10^{36} \hbar$	classical
<i>Nuclei and stars</i>		
Nuclear fusion reaction in star	ca. $1 - 5 \hbar$	quantum
Particle collision in accelerator	ca. $1 \hbar$	quantum
Explosion of gamma ray burster	ca. $10^{80} \hbar$	classical

Table 42 Some small systems in motion and the observed action values for the changes they undergo

There is another way to characterize the difference between a microscopic or quantum system on one side and a macroscopic or classical system on the other. A minimum action implies that the difference of action S between two successive observations of the same system, spaced by a time Δt , is limited. Therefore the system follows

$$S(t + \Delta t) - S(t) = (E + \Delta E)(t + \Delta t) - Et = E\Delta t + t\Delta E + \Delta E\Delta t \geq \frac{\hbar}{2} . \quad (391)$$

Since the value of the energy E and of the time t – but not that of ΔE or of Δt – can be set to zero if one chooses a suitable observer, we follow that the existence of a quantum of action implies that in any system the evolution is constrained by

$$\Delta E\Delta t \geq \frac{\hbar}{2} . \quad (392)$$

By a similar reasoning we find that for any system the position and momentum values are constrained by Challenge 65

$$\Delta x\Delta p \geq \frac{\hbar}{2} . \quad (393)$$

These two famous relations were called *indeterminacy relations* by their discoverer, Werner Heisenberg. * The name was translated incorrectly into English, where they often are called ‘uncertainty relations’. However, this latter name is wrong: the quantities are not uncertain, but *undetermined*. Due to the quantum of action, system observables have *no* definite value. There is *no* way to ascribe a precise value to momentum, position and other observables of a quantum system. Any system whose indeterminacies are of the order of \hbar is a quantum system; if the uncertainty product is much larger, the system is classical, and classical physics is sufficient for its description. In other words, even though classical physics assumes that there are *no* measurement uncertainties in nature, a system is classical only if its uncertainties are *large* compared to the minimum possible ones. As a result, quantum theory is also necessary in all those cases in which one tries to measure some quantity as precisely as possible.

The indeterminacy relations again show that *motion cannot be observed to infinite precision*. In other words, the microscopic world is *fuzzy*. This strange result has many important and many curious consequences. For example, if motion cannot be observed with infinite

* One often hears the myth that the indeterminacy relation for energy and time has another weight than the one for momentum and position. That is wrong; it is a myth propagated by the older generation of physicists. This myth survived through many textbooks for over 70 years; just forget it, as it is incorrect. It is essential to remember that all four quantities appearing in the inequalities are quantities describing the *internal* properties of the system. In particular, it means that t is some time variable deduced from changes observed *inside* the system and *not* the external time coordinate measured by an outside clock, in the same way that the position x is *not* the external space coordinate, but the position characterizing the system.

Ref. 5

Werner Heisenberg (1901–1976) was an important German theoretical physicist and an excellent table tennis and tennis player. In 1925, as a young man, he developed, with some help by Max Born and Pascual Jordan, the first version of quantum theory; from it he deduced the indeterminacy relations. For these achievements he received the Nobel prize for physics in 1932. He also worked on nuclear physics and on turbulence. During the second world war, he worked in the German nuclear fission program. After the war, he published several successful books on philosophical questions in physics and he unsuccessfully tried, with some half-hearted help by Wolfgang Pauli, to find a unified description of nature based on quantum theory, the ‘world formula’.

precision, the very concept of motion needs to be used with great care, as it cannot be applied in certain situations. In a sense, the rest of our quest is an exploration of the implications of this result. In fact, as long as space-time is *flat*, it turns out that we *can* keep motion as a concept describing observations, provided we remain aware of the limitations of the quantum principle.

See page 108

In particular, the quantum of action implies short-time deviations from energy, momentum, and angular momentum conservation in microscopic systems. Now, in the first part of our mountain ascent we realized that any type of nonconservation implies the existence of surprises in nature. Well, here are some more.

Since uniform motion does not exist in the precise meaning of the term, a system moving in one dimension only, such as the hand of a clock, always has a possibility to move a bit in the opposite direction, thus leading to incorrect readings. Indeed, quantum theory predicts that *clocks have limits*, and that perfect clocks do not exist. In fact, quantum theory implies that strictly speaking, one-dimensional motion does not exist.

Challenge 82

Obviously, the limitations apply also to meter bars. Thus the quantum of action is responsible on one hand for the possibility to perform measurements at all, and on the other hand for their limitations.

In addition, it follows from the quantum of action that any observer must be *large* to be inertial or freely falling, as only large systems approximate inertial motion. *An observer cannot be microscopic*. If humans were not macroscopic, they could neither observe nor study motion.

Due to the finite accuracy with which microscopic motion can be observed, faster than light motion should be possible in the microscopic domain. Quantum theory thus predicts *tachyons*, at least over short time intervals. For the same reason, also *motion backwards in time* should be possible over microscopic times and distances. In short, a quantum of action implies the existence of microscopic time travel.

Challenge 99

But there is more: the quantum of action implies that *there is no permanence in nature*. Imagine a moving car suddenly disappearing for ever. In such a situation neither momentum nor energy would be conserved. The action change for such a disappearance is large compared to \hbar , so that its observation would contradict even classical physics, as you might want to check. However, the quantum of action allows that a *microscopic* particle, such as an electron, disappears for a *short* time, provided it reappears afterwards.

The quantum of action also implies that *the vacuum is not empty*. If one looks at empty space twice in a row, the two observations being spaced by a tiny time interval, some energy will be observed the second time. If the time interval is short enough, due to the quantum of action, matter particles will be observed. Indeed, particles can appear anywhere from nowhere, and disappear just afterwards, as the action limit requires it. In other words, classical physics' idea of an *empty* vacuum is correct only when observed over *long* time scales. In summary, nature shows short time appearance and disappearance of matter.

Challenge 133

The quantum of action also implies that compass needles cannot work. If one looks twice in a row at a compass needle or even at a house, we usually observe that they stay oriented in the same direction. But since physical action has the same unit as angular momentum, a minimum value for action also means a minimum value for angular momentum. Therefore, every macroscopic object has a minimum value for its rotation. In other words, quantum

This is a section of the freely downloadable e-textbook

Motion Mountain

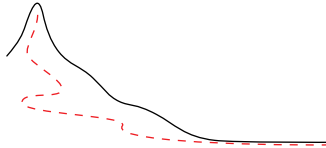

Hiking beyond space and time along the concepts of modern physics

available at
www.motionmountain.org

Copyright © 1997, 1998, 1999, 2000, 2001, 2002 by Christoph Schiller

To the kind reader

In exchange for getting this section for free, I ask you for a short email on some of the following:

- Which page was boring?
- Did you find any mistakes?
- What else were you expecting?
- What was hard to understand?

Of course, any other suggestion is welcome. This section is part of a physics text written over many years. The text lives and grows through the feedback from its readers, who help to improve and to complete it. For a particularly useful contribution (send it in english, italian, dutch, german, spanish, portuguese, or french) you will be mentioned in the foreword of the text, or receive a small reward, or both.

Enjoy!

Christoph Schiller
cs@motionmountain.org

Challenge 116

theory predicts that *in everyday life, everything rotates*. Lack of rotation exists only approximately, when observations are spaced by long time intervals.

For microscopic systems, the situation is more involved. If their rotation angle *can* be observed, such as for molecules, they behave like macroscopic objects: their position and their orientation are fuzzy. But for those systems whose rotation angle *cannot* be observed, the quantum of action turns out to have somewhat different consequences. Their angular momentum is limited to values which are multiples of $\hbar/2$. As a result, all microscopic bound systems, such as molecules, atoms, or nuclei, contain rotational motion and rotating components.

But there is more to come. A minimum action implies that cages in zoos are dangerous and banks are not safe. A cage is a feature requiring a lot of energy to be overcome. Mathematically, the wall of a cage is an energy hill, similar to the one shown in Figure 179. If a particle on one side of the hill has momentum p , it is simple to show that the particle can be observed on the other side of the hill, at position Δx , even if its kinetic energy $p^2/2m$ is *smaller* than the height E of the hill. In everyday life this is impossible. But imagine that the missing momentum $\Delta p = \sqrt{2mE - p^2}$ to overcome the hill satisfies $\Delta x \Delta p \geq \hbar/2$. The quantum of action thus implies that a hill of width

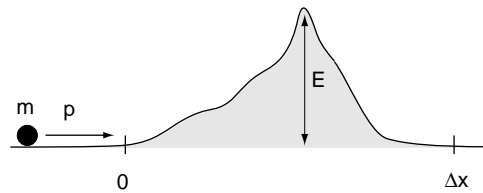

Figure 179 Hills are never high enough

$$\Delta x \leq \frac{\hbar/2}{\sqrt{2mE - p^2}} \tag{394}$$

is *not* an obstacle to the particle. But this is not all. Since the value of the particle momentum p is itself undetermined, a particle can overcome the hill even if the hill is *wider* than value (394), though the broader it is the smaller the probability is. As a result, any particle can overcome *any* obstacle. This effect, for obvious reasons, is called the *tunnelling effect*. In short, the minimum action principle implies that there are no safe boxes in nature. Due to tunnelling, *matter is not impenetrable*, in contrast to everyday, classical observation. Can you explain why lion cages work *despite* the quantum of action?

Challenge 150

By the way, the quantum of action implies that a particle with a kinetic energy larger than the energy height of a hill can get reflected. Classically this is impossible. Can you explain the observation?

Challenge 167

The minimum action principle also implies that book shelves are dangerous. Shelves are obstacles to motion. A book in a shelf is in the same situation as the mass in Figure 180; the mass is surrounded by energy hills hindering its escape to the outer, lower energy world. Now, due to the tunnelling effect, escape is always possible. The same picture applies to a branch of a tree, a nail in a wall, or to anything attached to anything else. Fixing things to each other is never for ever. We will find out that every example of light emission, and

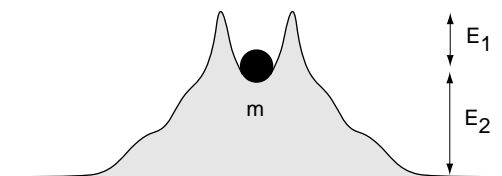

Figure 180 Leaving enclosures

even radioactivity, results from this effect. In short, there are no stable excited systems in nature. For the same reason by the way, *no* memory can be perfect. Can you confirm the deduction? The quantum of action thus implies that *decay is part of nature*. Note that decay often appears in everyday life, where it just has a different name: *breaking*. In fact, all cases in which something breaks require the quantum of action for their description. Obviously, the cause of breaking is often classical, but the *mechanism* of breaking is always quantum.

Challenge 184

Taking a more general view, also *aging* and *death* result from the quantum of action. Classically, death does not exist; can this be the reason that so many believe in immortality or eternal youth?

Challenge 201

Obviously, a minimum action also implies that matter cannot be continuous, but must be composed of smallest entities. Indeed, the flow of a truly continuous material would contradict the quantum principle. Can you give the precise argument? Of course, at this point of our adventure, the non-continuity of matter is no news any more. But in addition, the quantum of action implies that even *radiation* cannot be continuous. As Albert Einstein stated clearly for the first time, light is made of particles. More generally, the quantum of action implies that in nature *all flows and all waves are made of microscopic particles*. The term ‘microscopic’ or ‘quantum’ is essential, as such particles do *not* behave like little stones. We have already encountered several differences, and will encounter more of them shortly. For this reasons, microscopic particles should bear a special name; but all proposals, such as *quantons*, have not caught on yet.

Challenge 218

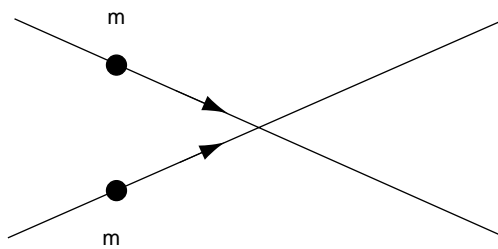

Figure 181 Identical objects with crossing paths

to ever notice it. For example, in a gas it is *impossible*, due to the quantum of action, to follow particles moving around and to say which particle is which. Can you confirm this deduction and specify the conditions using the indeterminacy relations? In summary, in nature *it is impossible to distinguish identical particles*. Can you guess what happens in the case of light?

The quantum of action has several strange consequences for microscopic particles. Take two of them with the same mass and the same composition. Imagine that their paths cross, and that at the crossing they approach each other to small distances, as shown in Figure 181. A minimum action implies that in such a situation, if the distance becomes small enough, the two particles can switch

role without anybody being able to avoid or

Challenge 235

Challenge 252

But matter deserves still more attention. Imagine two particles, even two different ones, approaching each other to small distances, as shown in Figure 182. We know that if the approach distance gets small, things get fuzzy. Now, if something happens in that small domain in such a way that the resulting outgoing products have the same total momentum and energy as the incoming ones, the minimum action principle makes such processes possible. Indeed, ruling out such processes would imply that arbitrary small actions could be observed, thus eliminating nature’s fuzziness, as you might want to check by yourself. In short, *a minimum action allows transformation of matter*. One also says that the quantum of action allows particle *reactions*. In fact, we will discover that *all* kinds of reactions in

Challenge 269

nature, including chemical and nuclear ones, are only due to the existence of the quantum of action.

But there is more. Due to the indeterminacy relations, it is impossible to give a definite value to both the momentum and the position of a particle. Obviously, this is also impossible for all the components of a measurement set-up or an observer. This implies that initial conditions – both for a system *and* for the measurement set-up – cannot be exactly duplicated. A minimum action thus implies that whenever an experiment on a microscopic system is performed twice, the outcome will be *different*. The result would be the same only if both the system and the observer would be in exactly the same condition in both situations. This turns out to be impossible, both due to the second principle of thermodynamics and due to the quantum principle. Therefore, *microscopic systems behave randomly*. Obviously, there will be some *average* outcome; nevertheless, microscopic observations are probabilistic. Albert Einstein found this conclusion of quantum theory the most difficult to swallow, as this randomness implies that the behaviour of quantum systems is strikingly different from that of classical systems. But the conclusion is unavoidable: nature behaves randomly.

A good example is given by trains. Einstein used trains to develop and explain relativity. But trains are also important for quantum physics. Everybody knows that one can use a train window to look either at the *outside* landscape or, by concentrating on the reflected image, to observe some interesting person *inside* the carriage. In other words, glass reflects some of the light particles and lets some others pass through. A random selection of light particles, yet with constant average, is reflected by the glass. Partial reflection is thus similar to the tunnel effect. Indeed, the partial reflection of glass is a result of the quantum of action. Again, the situation can be described by classical physics, but the mechanism cannot be explained without quantum theory. Without the quantum of action, train trips would be much more boring.

Finally, the quantum of action implies a famous result about the *path* of particles. If a particle travels from a point to another, there is no way to say which path it has taken in between. Indeed, in order to distinguish among the possible paths, actions smaller than $\hbar/2$ would have to be measured. In particular, if a particle is sent through a screen with two nearby slits, it is usually impossible to say through which slit it passed to the other side. The impossibility is fundamental. As we will find out soon, this impossibility also leads to particle interference.

We will also discover that the quantum of action is the origin for the importance of the action observable in classical physics. In fact, the existence of a *minimal* action is the reason for the *least* action principle of classical physics.

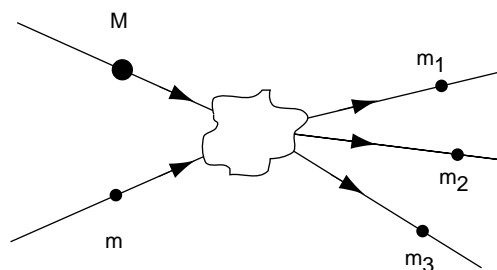

Figure 182 Transformation through reaction

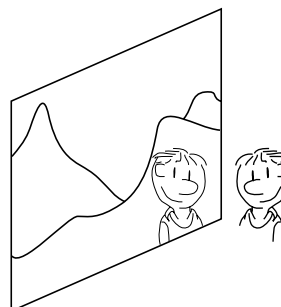

Figure 183 How do train windows manage to show two superimposed images?

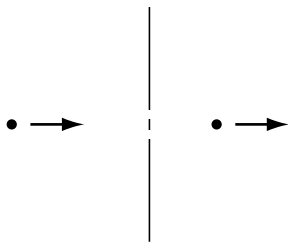

Figure 184 A particle and a screen with two nearby slits

Don't all these deductions look wrong or at least crazy? In fact, if you made any of these statements in court, maybe even under oath, you would be likely to end up in prison! However, all above statements are correct, as they are all confirmed by experiment. And the surprises are by far not finished. You might have noticed that so far, no situation related to electricity, to the nuclear interactions, or to gravity was included. In these domains the surprises are even more astonishing; the observation of antimatter, of electric current flow without resistance, of the motion inside muscles, of vacuum energy, of nuclear reactions

in stars, and maybe soon of boiling empty space, will fascinate you as much as they have fascinated and still fascinate thousands of researchers.

In particular, the consequences of the quantum of action on the early universe are simply mind-boggling. Just try to explore for yourself its influence on the big bang. Together, all these topics will lead us towards the top of motion mountain. The topics are so strange, so incredible, and at the same time so numerous that quantum physics can be rightly called the description of motion for *crazy* scientists. In a sense, this is the generalization of the previous definition, when we called quantum physics the description of motion related to pleasure.

Challenge 286

In order to continue towards the top of motion mountain, our next task will be the study of our classical standard of motion: the motion of light.

17. Light – the strange consequences of the quantum of action

... alle Wesen leben vom Lichte,
jedes glückliche Geschöpfe ...
Friedrich Schiller*

What is colour?

If all the colours of materials are quantum effects, as just argued, it becomes even more interesting to study the properties of light in the light of the quantum of action. If in nature there is a minimum change, there should also be a minimum illumination. Such a result has been indirectly predicted by Epicurus (341–271 BCE) already in ancient Greece, when he stated that light is a stream of little particles.

Ref. 6

But our eye does not detect light particles. We need devices to help us. A simple way is to start with a screen behind a prism illuminated with white light. The light is split into colours. When the screen is put further and further away, the illumination intensity cannot become infinitely small, as that would contradict the quantum of action. To check this prediction, we only need some black and white photographic film. Everybody knows that film is blackened by daylight of any colour; at medium light intensities it becomes dark grey and at lower

* '... all beings live of light, every happy creature ...' Friedrich Schiller (1759, Marbach–1805, Weimar), important German poet, playwright, and historian.

intensities light grey. Looking at an extremely light grey film under the microscope, we discover that even under uniform illumination the grey shade actually is a more or less dense collections of black spots. Exposed film does *not* show a homogeneous colour; on the contrary, it reacts as if light is made of small particles. In fact, this is a general observation: whenever sensitive light detectors are constructed with the aim to ‘see’ as accurately as possible, as e.g. in dark environments, one always finds that light manifests itself as a stream of *particles*. They are called *photons*, a term that appeared in 1926, superseding the term ‘light quanta’ in usage before. A low or high light intensity is simply a small or high number of photons.

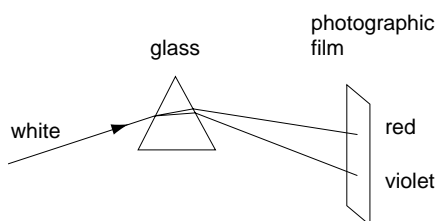

Figure 185 Illumination by pure-colour light

These experiments thus show that the continuum description of light is *not correct* for small intensities. More precise measurements confirm the role of the quantum of action: every photon leads to the *same* amount of change. This amount of change is the *minimal* amount of change that



Figure 186 Observation of photons

Indeed, if a minimum action would not exist, light could be packaged into arbitrary small amounts. On the contrary, the classical description of light by a *continuous* state function $A(t, x)$ or $F(t, x)$, whose evolution is described by a principle of least action, is *wrong*, as it does *not* describe the observed particle effects. Another, modified description is required. The modification has to be important only at low light intensities, since at high intensities the classical Lagrangian accurately describes all experimental observations.*

At which intensities does light cease to behave as a continuous wave? Our eye can help us to find a limit. Human eyesight does not allow to consciously distinguish single photons, even though experiments show that the hardware of the eye is able to do this. The faintest stars which can be seen at night produce a light intensity of about 0.6 nW/m^2 . Since the pupil of the eye is quite small, and as we are not able to see individual photons, photons must have small energy indeed.

In today’s laboratory experiments, recording and counting individual photons is standard practice. Photon counters are part of many spectroscopy set-ups, such as those used to measure smallest concentration of materials. For example, they help to detect drugs in human

* This transition from the classical case to the quantum case used to be called *quantization*. The concept and the ideas behind it are only of historical interest today.

See page 358

Ref. 7

hair. All these experiments thus prove directly that light is a stream of particles, as Epicure had advanced in ancient Greece.

This and many other experiments show that a beam of light of frequency f , which determines its colour, is accurately described as a stream of photons, each with the *same* energy E given by

$$E = \hbar 2\pi f = \hbar \omega \quad . \quad (395)$$

This shows that for light, the smallest measurable action is given by the quantum of action \hbar . The reasons and implications of the fact that this is the *double* of the smallest action observable in nature will unfold during the rest of our walk. In summary, *colour* is a property of photons. A coloured light beam is a hailstorm of corresponding photons.

The value of *Planck's constant* can be determined from measurements of black bodies or other light sources. The result

$$\hbar = 1.1 \cdot 10^{-34} \text{ Js} \quad (396)$$

is so small that we understand why photons go unnoticed by humans. Indeed, in normal light conditions the photon numbers are so high that the continuum approximation for the electromagnetic field is of high accuracy. In the dark, the insensitivity of the signal processing of the human eye, in particular the slowness of the light receptors, makes photon counting impossible. The eye is not far from maximum possible sensitivity though; from the numbers given above about dim stars we can deduce that humans are able to see *consciously* flashes of about half a dozen photons.

What other properties do photons have? Quite a collection, as we will see. We will deduce them systematically in the following, using the data collected in classical physics, while taking the quantum of action firmly into account. For example, photons have no mass* and no electric charge. Can you confirm this?

We know that light can *hit* objects. Since the energy and the speed of photons is known, we guess that the photon momentum obeys

$$p = \hbar \frac{2\pi}{\lambda} \quad \text{or} \quad \mathbf{p} = \hbar \mathbf{k} \quad . \quad (397)$$

In other words, if light is made of particles, we should be able to play billiard with them. This is indeed possible, as Arthur Compton showed in a famous experiment in 1923. He directed X-rays, which are high energy photons, onto graphite, a material in which electrons move almost freely. He found that whenever the electrons in the material get hit by the X-ray photons, the deflected X-rays change colour. As expected, the strength of the hit depends on the deflection angle of the photon. From the colour change and the reflection angle, Compton confirmed that the photon momentum obeys the above expression. All other experiments agree that photons have momentum. For example, when an atom *emits* light, the atom feels a *recoil*; the momentum again turns out to be given by the same value (397). In short, every photon has momentum.

The value of photon momentum also respects the indeterminacy principle; in the same way that it is impossible to measure exactly both the wavelength of a wave and the position

Ref. 8 * The present upper limit for the mass of a photon is 10^{-51} kg.

See page 398

Ref. 7

Challenge 303

Challenge 320

Challenge 337

Ref. 9

Challenge 354 of its crest, it becomes impossible to measure both the momentum and the position of a photon. Can you confirm this? In other words, the value of the photon momentum can also be seen as a direct consequence of the quantum of action.

From our study of classical physics we know that light has more properties than its colour: light can be *polarized*. That is only a complicated way to say that light can *turn* objects it shines on. Or again, light has an angular momentum oriented along the axis of propagation.

See page 371 What about photons? Measurements consistently find that each light particle carries an *angular momentum* of \hbar , also called its *spin*. Photons somehow ‘turn’. The direction of the spin is either parallel or antiparallel to the direction of motion. Again, the magnitude of the photon spin is not a surprise; it confirms the classical relation $L = E/\omega$ between energy and angular momentum that we found in the section on classical electrodynamics. Note that in contrast to intuition, the angular momentum of a photon is fixed, and thus *independent* of its energy. Even the photons with the highest energy have $L = \hbar$. Of course, the value of the spin also respects the limit given by the quantum of action. The fact that the spin is \hbar and not $\hbar/2$ has important consequences; they will become clear shortly.

Challenge 371

What is light? – Again

La lumière est un mouvement lumineux de corps lumineux. *

In the 17th century, Blaise Pascal ** used this sentence to make fun about certain physicists. He ridiculed (rightly so) the blatant use of a circular definition. Of course, he was right; in his time, the definition was indeed circular, as no meaning could be given to any of the terms. But as usual, whenever an observation is studied with care by physicists, they give philosophers a beating. All those originally undefined terms now have a definite meaning: light is indeed a type of motion, this motion can rightly be called luminary because in opposition to motion of material bodies, it has the unique property $v = c$, and the luminous bodies, today called photons, are characterized and differentiated from all other particles by the dispersion relation $E = \hbar k$, by their spin $L = \hbar$, by the vanishing value of all other quantum numbers, and by being the quanta of the electromagnetic field.

In short, *light is a stream of photons*. The existence of photons is the first example of a general property of the world on small scales: *all waves and all flows in nature are made of particles*. In the old days of physics, books used to discuss at length a so-called *wave-particle duality*. Large numbers of microscopic particles do indeed behave as waves. We will see shortly that this is the case even for matter. The fundamental constituents of *all* waves are quantum particles. There is *no* exception. The everyday, continuum description of light is thus similar in many aspects to the description of water as a continuous fluid; photons are atoms of light, and continuity is an approximation for large particle numbers.

However, a lot is not clear yet. Where inside matter do these monochromatic photons come from? Even more interestingly, if light is made of particles, all electromagnetic fields, even static ones, must be made of photons as well. However, in static fields nothing is flow-

* Light is the luminary movement of luminous bodies.

** Blaise Pascal (1623, Clermont–1662, Paris) important French mathematician and physicist up to the age of twenty-six; he then turned theologian and philosopher.

ing. How is this apparent contradiction solved? And what effects does the particle aspect have on these static fields?

An even more important question remains: photons clearly do *not* behave like small stones at all: stones do not form waves and do not interfere. The properties of photons thus require some more careful study. Let us go on.

Size of photons

First of all, we might ask: what are these photons made of? All experiments so far, performed down to the present limit of about 10^{-20} m, give the same answer: ‘we can’t find anything’. That is consistent both with a vanishing mass and a vanishing size of photons; indeed, one intuitively expects any body with a finite size to have a finite mass. Thus, even though experiments give only an upper limit, it is consistent to claim that a photon has *no size*.

A particle with no size cannot have any constituents. A photon thus cannot be divided into smaller entities. For this reason people refer to photons as *elementary* particles. We will give some strong additional arguments for this deduction soon. (Can you find one?) This is a strange result. How can a photon have vanishing size, have no constituents, and still be *something*? The answer will appear later on. At the moment we simply have to accept the situation as it is. We therefore turn to an easier question.

Challenge 388

Are photons countable? – Squeezed light

Above we showed that in order to count photons, the simplest way is to absorb them on a screen. Everybody knows that a light beam crossing a dark room cannot be seen – except if it hits dust or some object, which means absorption in the detection device, such as the eye. How can one count photons without destroying them?

It is possible to reflect photons on a mirror, and to measure the recoil of the mirror. This seems almost unbelievable, but nowadays the effect is becoming measurable even for small number of photons. For example, it is becoming of importance in the mirrors used in gravitational wave detectors, where the position of laser mirrors has to be measured to high precision.

Another way of counting photons without destroying them uses special high quality laser cavities. Using smartly placed atoms inside such a cavity, it is possible to count the number of photons by the effect they have on these atoms.

However, once we know how to count photons and start doing so, the next difficulty appears straight away. Measurements show that even the best light beams, from the most sophisticated lasers, *fluctuate* in intensity. This does not come as a surprise: if a steady beam would *not* fluctuate, observing it twice in a row would yield a vanishing value for the action. However, there is a minimum action in nature, namely $\hbar/2$. Thus any beam and any flow in nature fluctuates. But that is not all.

A light beam is described by its intensity and its phase. The change – or action – occurring while a beam moves is given by the variation in the product of intensity and phase. Experiments confirm the obvious deduction: intensity and phase of beams behave like momentum and position of particles: they obey an indeterminacy relation. You can deduce it yourself, in

the same way we deduced Heisenberg’s relations. Using as characteristic intensity $I = E/\omega$ the energy per circular frequency, and calling the phase φ , we get*

$$\Delta I \Delta \varphi \geq \frac{\hbar}{2} . \tag{398}$$

For light from lamps, the product of the left side is much larger than the quantum of action. On the other hand, laser beams can (almost) reach the limit. Among these, light beams in which the two uncertainties strongly differ from each other are called *nonclassical light* or *squeezed light*; they are used in many modern research applications. Such light beams have to be treated carefully, as the smallest disturbances transform them back into usual laser beams, where the two uncertainties have the same value. An example of non-classical light are those beams with a given, fixed photon number, thus with an extremely large phase uncertainty.

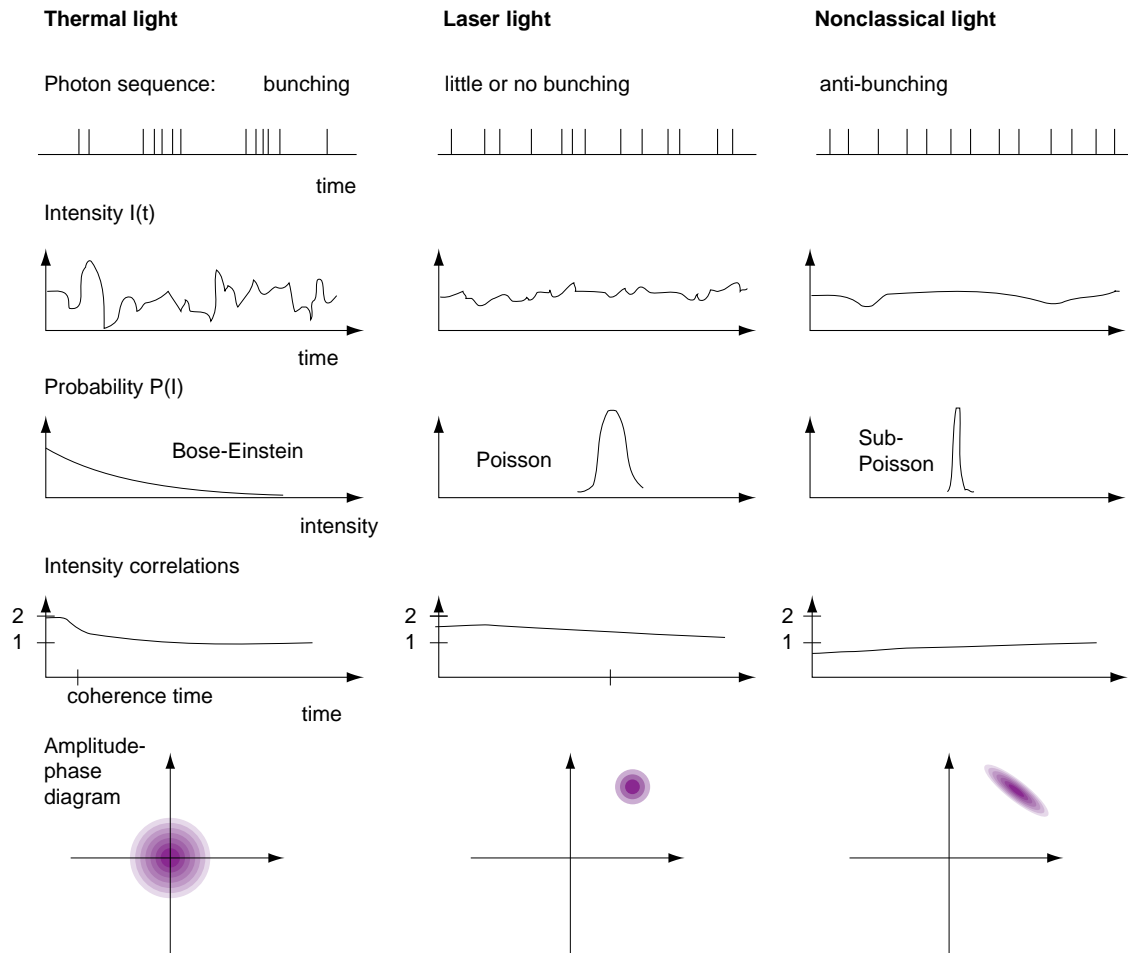

Figure 187 Various types of light

* A large photon number is assumed in the expression.

The observation of nonclassical light points to a strange consequence valid even for classical light: the number of photons in a light beam is *not* a defined quantity. In general it is *undetermined*, and it *fluctuates*. The number of photons at the beginning of a beam is not necessarily the same as at the end of the beam. Photons, in contrast to stones, cannot be counted precisely – as long as they move. Only within the limit set by indeterminacy an approximate number can be measured.

A limit example are those beams with an (almost) fixed phase. In them, the photon number fluctuates from zero to infinity. In other words, to produce a *coherent* laser beam, one must build a source in which the photon number is as undetermined as possible.

The other extreme is a beam with a fixed number of photons; in such a beam, the phase fluctuates erratically. Most daily life situations, such as the light from incandescent lamps, lie somewhere in the middle: both phase and intensity uncertainties are of similar magnitude.

As an aside, it turns out that in deep, dark intergalactic space, far from every star, there still are about 400 photons per cubic centimetre. But also this number, like the number of photons in a light beam, has its measurement indeterminacy. Can you estimate it?

Challenge 405

In summary, unlike little stones, *photons are not countable*. But that is not all; let us study some additional differences.

Position of photons

Where is a photon when it moves in a beam of light? Quantum theory gives a simple answer: nowhere in particular. The proof is given most spectacularly by the experiments which show that even a beam made of a *single* photon can be split, be led along two different paths, and then be recombined. The resulting interference shows that the single photon cannot be said to have taken either of the two paths. It must have taken both at the same time. Photons thus cannot be localized.

This impossibility of localization can be clarified somewhat in more detail. It is impossible to localize photons in the direction *transverse* to the motion. It is less difficult to localize photons *along* the motion direction. In this latter case, the quantum of action implies that the longitudinal position is uncertain within a value given by the wavelength of the corresponding colour. Can you confirm this?

Challenge 422

In particular, this means that photons *cannot* be simply visualized as short wave trains. Photons are truly *unlocalizable* entities specific to the quantum world.

Now, if photons can be almost localized along their motion, we can ask the following question: How are photons lined up in a light beam? Of course, we just saw that it does not make sense to speak of their *precise* position. But are photons in a perfect beam arriving in almost regular intervals or not?

The study of this question was not started by physicists, but by two astronomers, R. Hanbury-Brown and R.Q. Twiss, in 1956. They used a simple method to measure the probability that a second photon arrives at a given time after a first one. They simply split the beam, fixing one detector in one branch and varied the position of a second detector in the other branch.

Ref. 10

Applying this method to light beams, it turns out that all thermal light sources, i.e. lamps, show a simple result: if a photon hits, the probability that a second one hits just afterwards is

highest. Photon in lamps are *bunched*. There is a limit time for this high probability, called the *coherence time*. For larger times, the probability for bunching is low, and independent of the interval. The coherence time is characteristic for every light beam, or better, for every light source. In fact, it is more obvious to use the concept of *coherence length*, as it gives a clearer image of a light beam. For thermal lamps, the coherence length is only a few micrometers, a small multiple of the wavelength. The largest coherence lengths, up to over 100 000 km, are found in lasers. Interestingly, coherent light is even found in nature; certain stars have been found to emit coherent light.

Ref. 11

But even though the intensity of laser light is much less fluctuating than that of lamps, its photons still do not arrive in regular intervals. Laser light still shows some bunching, though with different statistics than lamp light. Light for which photons arrive regularly, showing so-called photon anti-bunching, is obviously nonclassical in the sense defined above; such light can be produced only by special experimental arrangements. The most extreme example is pursued at present by several research groups; they are trying to construct light sources which emit one photon at a time, at regular time intervals as often as possible.

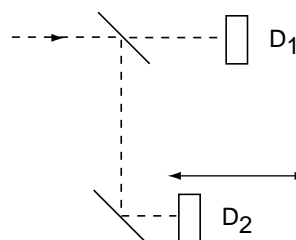

Figure 188 How to measure photon statistics

In summary, experiments force one to conclude that photons *cannot* be localized. It makes no sense to talk about the position of a photon in general; the idea makes only sense in some special situations, and then only approximately and as a statistical average.

Are photons necessary?

Also gibt es sie doch.
Max Planck*

In light of the results uncovered so far, the answer to the title question is obvious. On the other hand, the *photoelectric effect* is usually cited in school books as the first and most obvious experimental proof of the existence of photons. For certain metals, such as lithium or caesium, incident light leads to the emission of electrons. It is observed that the energy of the ejected electrons is *not* dependent on the intensity of the light, but only dependent on the difference between \hbar times its frequency and a material dependent threshold energy. In 1905, Albert Einstein predicted this result from the assumption that light is made of photons of energy $E = \hbar\omega$. He imagined that this energy is used partly to extract the electron over the threshold, and partly to give it kinetic energy. More photons only lead to more electrons, not to faster ones.

Einstein received the Nobel price for this explanation. But Einstein was a *genius*; that means he deduced the correct result by a somewhat incorrect reasoning. The (small) mistake was the prejudice that a classical, continuous light beam would produce a different

* 'Thus they do exist, after all'. Max Planck, in later years, said this after standing silently, for a long time, in front of an apparatus which counted single photons by producing a click for each one it detected. It is not a secret that for a large part of his life, Planck was not a friend of the photon concept, even though his own results were the starting point for its introduction.

effect. It does not take a lot to imagine that a classical, continuous electromagnetic field interacting with discrete matter, made of discrete atoms containing discrete electrons, leads to exactly the same result, if the motion of electrons is described by quantum theory. Several researchers confirmed this point already early in the twentieth century. The photoelectric effect by itself does *not* require photons for its explanation.

Ref. 12

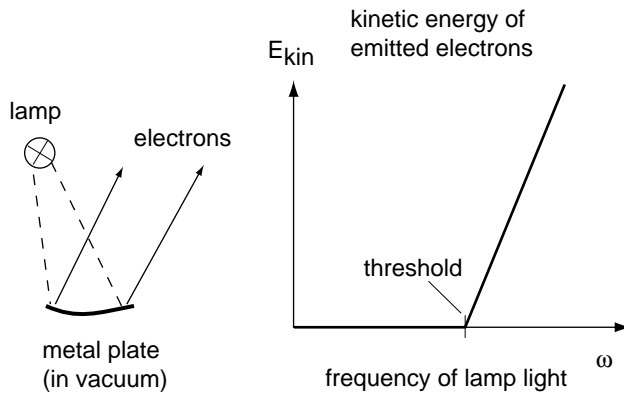

Figure 189 The kinetic energy of electrons emitted in the photoelectric effect

by a hot body is *finite* only due to the *quantum* nature of the processes leading to light emission. A description of the processes by classical electrodynamics would lead to *infinite* amounts of radiated energy. These two influential papers convinced most of the sceptic physics researchers at the time that it was worthwhile to study quantum phenomena in more detail.

Indeed, many were not convinced. Historically, the most important argument for the *necessity* of light quanta was given by Henri Poincaré. In 1911 and 1912, at age 57 and only a few months before his death, he published two influential papers proving that the radiation law of black bodies, the one in which the quantum of action had been discovered by Max Planck, *requires* the introduction of photons. He also showed that the amount of radiation emitted

Ref. 13

Poincaré did not know about $S \geq \hbar/2$; yet his argument is based on the observation that light of a given frequency always has a minimum intensity, namely one photon. Even splitting such a one photon beam into two beams, e.g. using a half-silvered mirror, does produce two beams. However, there is no way to find more than one photon in those two beams together.

Another interesting experiment requiring photons is the observation of ‘molecules of photons’. In 1995, Jacobson et al. predicted that the de Broglie wavelength of a *packet* of photons could be observed. Following quantum theory it is given by the wavelength of a single photon divided by the number of photons in the packet. The team argued that the packet wavelength could be observable if one would be able to split and recombine such packets without destroying the cohesion within the packet. In 1999, this effect was indeed observed by de Pádua and his brazilian research group. They used a nonlinear crystal to create what they call a *biphoton*, and observed its interference properties, finding a reduction of the effective wavelength by the predicted factor of two.

Ref. 15

Another argument for the necessity of photons is the mentioned recoil felt by atoms emitting light. The recoil measured in these cases is best explained by the emission of a photon in a particular direction. Classical electrodynamics predicts the emission of a spherical wave, with no preferred direction.

Obviously, the observation of *nonclassical light*, also called *squeezed light*, also argues for the existence of photons, as squeezed light proves that photons indeed are an *intrinsic*

Ref. 14 aspect of light, necessary even when no interactions with matter play a role.

In summary, the concept of photon is indeed *necessary* for a precise description of light, but the details are often subtle, as its properties are often unusual and require a change in thinking habits. To avoid this, all school books stop discussing photons after the photoelectric effect. That is a pity; things get interesting only after that. To savour the fascination, take the following issue. Obviously, all electromagnetic fields are made of photons. Indeed, photons have been counted for gamma rays, X-rays, ultraviolet light, visible light, and infrared light. However, for lower frequencies, photons have not been detected yet. Can you imagine what would be necessary to count the photons emitted from a radio station?

Challenge 439

The issue directly leads to the most important question of all:

How can a wave be made of particles?

Fünfzig Jahre intensiven Nachdenkens haben mich der Antwort auf die Frage ‘Was sind Lichtquanten?’ nicht näher gebracht. Natürlich bildet sich heute jeder Wicht ein, er wisse die Antwort. Doch da täuscht er sich.
Albert Einstein, 1951 *

If a light wave is made of particles, one must be able to explain each and every wave properties with help of photons. The experiments mentioned above already hinted that this is possible only because photons are *quantum* particles. Let us take a more detailed look at this connection.

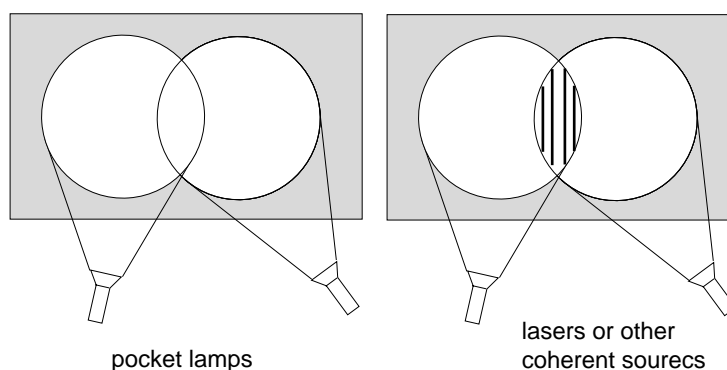

Figure 190 Light crossing light

- Light can *cross* other light undisturbed. This observation is not hard to explain with photons; since photons do not interact with each other, and since they are point-like, they ‘never’ hit each other. In fact, there is an extremely small probability for their interaction, as will be found below, but this effect is not observable in everyday life.

But the problems are not finished yet. If two light beams of identical frequencies and fixed phase relation cross, we observe alternating bright and dark regions, so-called *interference fringes*. How do these interference fringes appear? Obviously, photons are not detected in

* ‘Fifty years of intense reflection have not brought me nearer to the answer of the question ‘What are light quanta?’ Of course nowadays every little mind thinks he knows the answer. But he is wrong.’

the dark regions. How can this be? There is only one possible way to answer: the brightness gives the *probability* for a photon to arrive at that place. Some additional thinking leads to the following conclusion:

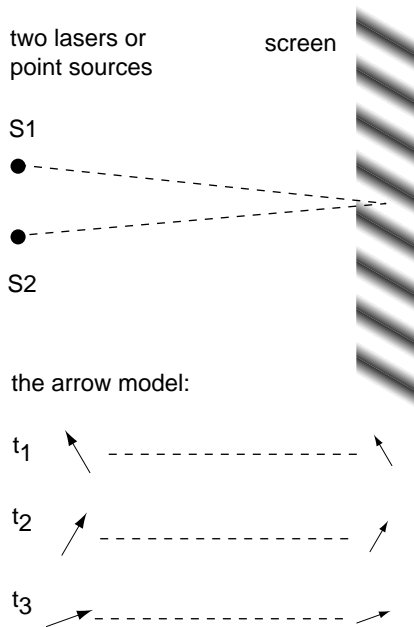

Figure 191 Interference and the description of light with arrows (at one particular instant of time)

In between regions give in between shades. Obviously, for the case of pocket lamps the brightness also behaves as expected: the averages then simply add up, as in the common region in the left case of Figure 190.

You might want to calculate the distance of the lines when the source distance, the colour, and the distance to the screen is given.

Obviously, the photon model implies that interference patterns are built up as the sum of a large number of one-photon hits. Using low intensity beams, we should therefore be able to see how these little spots slowly build up an interference pattern, by accumulating at the bright spots, and never hitting the dark regions. That is indeed the case. Many experiments have confirmed this description.

It is important to stress that interference of two light beams is *not* the result of two different photons cancelling out or adding each other up. The cancelling would be against energy and momentum conservation. Interference is an effect valid for each photon separately, resulting from the fact that each photon is spread out over the whole set-up; each photon takes all possible paths and interferes. As Dirac said, *each photon interferes only with itself*. Interference only works because photons are quanta, and not at all classical particles.

That leads to a famous paradox: if a photon can interfere only with itself, how can two laser beams from two different lasers show interference? The answer of quantum physics

* The model gives a correct description of light with the exception that it neglects polarization.

(1) The probability of a photon arriving somewhere is given by the *square of an arrow*;

(2) the final arrow is the *sum* of all arrows getting there, taking all possible paths;

(3) the arrows direction stays fixed in space when photons move;

(4) the length of an arrow shrinks with the square of the travelled distance;

(5) photons emitted by one-coloured sources are emitted with arrows of constant length pointing in direction ωt ; in other words, such monochromatic sources spit out photons with a *rotating* mouth.

(6) photons emitted by thermal sources, such as pocket lamps, are emitted with arrows of constant length pointing in *random* directions.

With this model* we can explain the stripes seen in laser experiments, such as those of Figure 190 and Figure 191. You can check that in some regions, the two arrows travelling through the two slits add up to zero *for all times*. No photons are detected there. In other regions, the arrows always add up to the maximal value. These regions are always bright.

Challenge 456

Ref. 16

is simple but strange: in the region where the beams interfere, there is no way to say from which source a photon is arriving. Photons are quantons; the photons in the crossing region *cannot* be said to come from a specific source. Photons in the interference region are quantons on their own right, which indeed interfere only with themselves. In that region, one cannot honestly say that light is a flow of photons. That is the strange result of the quantum of action.

Waves also show *diffraction*. To understand this phenomenon with photons, let us start with a simple mirror and study *reflection* first. Photons (like any quantum particle) move from source to detector in *all* ways possible. As the discoverer of this explanation, Richard Feynman,* likes to stress, the term ‘all’ has to be taken literally. This was not a big deal in the explanation of interference. But in order to understand a mirror we have to include all possibilities, as crazy as they seem, as shown in Figure 192.

For a mirror, we have to add up the arrows arriving at the same time at the location of the image. They are shown, for each path, below the corresponding segment of the mirror. The arrow sum shows that light indeed does arrive at the image. It also shows that most of the contributions is coming from those paths near the middle one. If we were to perform the same calculation for another direction, (almost) no light would get there. In summary, the rule that reflection occurs with incoming angle equal to the outgoing angle is an approximation only; the rule follows from the arrow model of light.

In fact, a detailed calculation, with more arrows, shows that the approximation is quite precise; the errors are much smaller than the wavelength of the light used.

The proof that light does indeed take all these strange paths is given by a more specialized mirror. As show in Figure 193, one can repeat the experiment with a mirror which reflects only along certain stripes. In this case, the stripes were carefully chosen such that the arrows reflected there all show a bias to one direction, namely to the left. The same calculation now

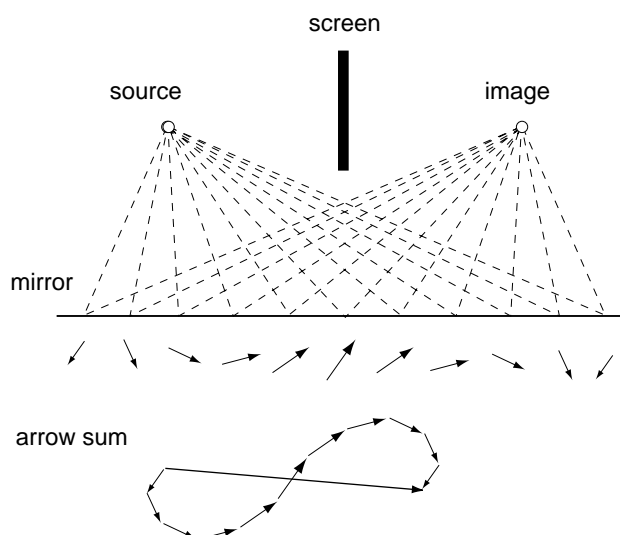

Figure 192 Light reflected by a mirror and the corresponding arrows (at one particular instant of time)

* Richard (‘Dick’) Phillips Feynman (1918, New York City–1988) US American physicist. One of the founders of quantum electrodynamics, he discovered the ‘sum-over-histories’ reformulation of quantum theory, made important contributions to the theory of the weak interaction and of quantum gravity, and coauthored a famous physics textbook, the *Feynman lectures of physics*. He was famously arrogant and disrespectful of authorities, deeply dedicated to physics and to enlarging knowledge in his domain, a well known collector of surprising explanations, and an author of several popularizing texts on his work and his life. He shared the 1965 Nobel prize in physics for his work on quantum electrodynamics.

shows that such a specialized mirror, usually called a *grating*, allows light to be reflected in unusual directions. And indeed, this behaviour is standard for waves, and called *diffraction*. In short, the arrow model for photons does allow to describe this wave property of light, provided that photons follow the mentioned crazy probability scheme. Do not get upset; as said before, quantum theory *is* the theory of crazy people.

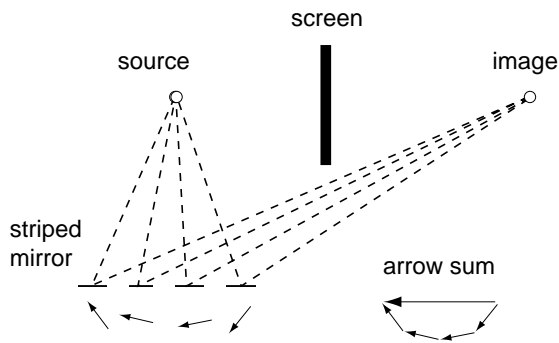

Figure 193 Light reflected by a badly placed mirror and by a grating

is faster in materials with high indices of refraction, the so-called *dense* materials. Just try it. However, experiments show that light in dense materials moves *slowly*. The wave picture has no difficulties explaining this observation. (Can you confirm it?) Historically, this was one of the arguments *against* the particle theory of light. However, the arrow model of light presented above is able to explain refraction properly. It is not difficult doing so.

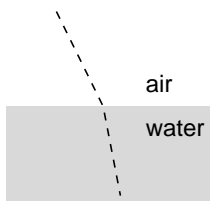

Figure 194 If light were made of little stones, they would move faster inside water

In waves, the fields *oscillate in time and space*. One way to show how waves can be made of particles is to show once for all how to build up a sine wave using a large number of photons. A sine wave is a coherent state of light. The way to build them up was explained by Glauber. In fact, to build a pure sine wave, one needs a superposition of a beam with one photon, a beam with two photons, a beam with three photons, continuing up to a beam with an infinite number of them. Together, they give a perfect sine wave. As expected, its photon number fluctuates to the highest degree possible.

If we repeat the calculation for non-ideal beams, we find that the indeterminacy relation for energy and time is respected; every emitted wave will possess a certain spectral width. Purely monochromatic light does not exist. Similarly, no system which emits a wave *at random* can produce a monochromatic wave. All experiments confirm these results.

If you are interested, you might want to check that the arrow model, with the approximations it generates by summing over all possible paths, automatically ensures that the quantum of action is indeed the smallest action that can be observed.

All waves have a *signal velocity*. As a consequence, waves show *refraction* when they move from one medium into another with different signal velocity. Interestingly, the naive particle picture of photons as little stones would imply that light is

Challenge 473

Challenge 490

Challenge 507

Challenge 524

Ref. 17

- Waves can be *polarized*. So far, we disregarded this property. In the photon picture, polarization is the result of carefully superposing beams of photons spinning clockwise and anticlockwise. Indeed, we know that linear polarization can be seen as a result of superposing circularly polarized light of both signs, using the proper phase. What seemed a curiosity in classical optics turns out to be the fundamental explanation of quantum theory.

Photons are *indistinguishable*. When two photons of the same colour cross, there is no way to say, after the crossing, which of the two is which. The quantum of action makes this impossible, as we know already. The indistinguishability of photons has an interesting consequence. It is impossible to say which emitted photon corresponds to which arriving photon. In other words, there is *no* way to follow the path of a photon in the way we are used to follow the path of a billiard ball. We will discover more about indistinguishability in the next chapter.

In summary, we find that light *can* indeed be built of particles. However, this is only possible under the condition that photons are not precisely countable, that they are not localizable, that they have no size, no charge, and no mass, that they carry an (approximate) phase, that they carry spin, that they are indistinguishable bosons, that they can take any path whatsoever, that one cannot pinpoint their origin, and that their probability to arrive somewhere is determined by the square of the sum of amplitudes for all possible paths. In other words, light can be made of particles only under the condition that these particles have extremely special, *quantum* properties. Only these quantum properties allow them to behave like waves, in the case that they are present in large numbers.

Quantons are thus quite different from usual particles. In fact, one can argue that the only particle aspects of photons are their quantized energy, momentum, and spin. In all other aspects photons are *not* like little stones. It is more honest to say that *photons are calculating devices to precisely describe observations about light*.

Ref. 18

This strange conclusion is the reason that earlier attempts to describe light as a stream of particles, such as the one by Newton, failed miserably, under the rightly deserved ridicule of all other scientists. Indeed, Newton upheld his idea against all experimental evidence, especially that on light's wave properties, something a physicist should never do. Only when people accepted that light is a wave, and then discovered and understood that quantum particles are different from everyday particles was the approach successful.

To separate between wave and particle descriptions, we can use the following criterion. Whenever matter and light interact, it is more appropriate to describe electromagnetic radiation as a wave if

$$\lambda \gg \frac{\hbar c}{kT} \quad , \quad (399)$$

where $k = 1.4 \cdot 10^{-23} \text{ J/K}$ is Boltzmann's constant. If the wavelength is much *smaller* than the right hand side, the particle description is most appropriate. If the two sides are of the same order of magnitude, both effects play a role.

Can light move faster than light? – Virtual photons

Light can move faster than c in vacuum, as well as slower than c . The quantum principle even explains the details. As long as the quantum principle is obeyed, the speed of a short

light flash can differ a bit from the official value, though only a *tiny* bit. Can you estimate the allowed difference in arrival time for a light flash from the dawn of times?

Challenge 541

The little arrow explanation also gives the same result. If one takes into account the crazy possibility that photons can move with any speed, one finds that all speeds very different from c cancel out. The only variation that remains, translated in distances, is the uncertainty of about one wavelength in the longitudinal direction which we mentioned already above.

Challenge 558

However, the most absurd results of the quantum of action appear when one studies *static* electric fields, such as the field around a charged metal sphere. Obviously, such a field must also be made of photons. How do they move? It turns out that static electric fields are built of *virtual* photons. In the case of static electric fields, virtual photons are *longitudinally* polarized, do *not* carry energy away, and cannot be observed as free particles.

In fact, the vector potential A allows *four* polarizations, corresponding to the four coordinates (t, x, y, z) . For the photons one usually talks about, the free or *real* photons, the polarizations in t and z direction cancel out, so that one observes only the x and y polarizations. For bound or *virtual* photons, the situation is different.

– CS – more to be written – CS –

In short, static electric and magnetic fields are continuous flows of virtual photons. Virtual photons can have mass, can have spin directions not pointing along the motion path, and can have momentum opposite to their direction of motion. All these properties are different from real photons. In this way, exchange of virtual photons leads to the *attraction* of bodies of different charge. In fact, virtual photons necessarily appear in any description of electromagnetic interactions; more about their effects, such as the famous attraction of neutral bodies, will be discussed later on.

In summary, light can indeed move faster than light, though only in amounts allowed by the quantum of action. For everyday situations, i.e. for cases with a high value of the action, all quantum effects average out, including light velocities different from c .

A different topic also belongs into this section. Not only the position, but also the energy of a single photon can be undefined. For example, certain materials split one photon of energy $\hbar\omega$ into two photons, whose two energies sum up to the original one. Quantum mechanics makes the strange prediction that the precise way the energy is split is known only when the energy of one of the two photons is measured. Only at that very instant the energy of the second photon is known. Before that, both photons have undefined energies. The process of energy fixing takes place *instantaneously*, even if the second photon is far away. We will explain below the background of this and similar strange effects, which seem to be faster than light but which are not. Indeed, such effects do not transmit energy or information faster than light.

Ref. 19

See page 546

Challenge 575

Electric fields

We saw that the quantum of action implies an uncertainty for light intensity. That implies a similar limit for electric and magnetic fields. This conclusion was first drawn by Bohr and Rosenfeld, in 1933. They started from the definition of the fields using a test particle of mass

Ref. 20

m and charge q , namely

$$m\mathbf{a} = q(\mathbf{E} + \mathbf{v} \times \mathbf{B}) \quad . \quad (400)$$

Since it is impossible to measure momentum and position of a particle, an indeterminacy for the electrical field

Challenge 592

$$\Delta E = \frac{\hbar}{q\Delta x T} \quad (401)$$

follows, where T is the measurement time. The value of electric fields, and similarly that of magnetic fields, is thus affected with an indeterminacy. The state of the electromagnetic fields behaves like the state of matter in this aspect.

18. Motion of matter – the end of classical physics

Wine glasses and pencils

All great things begin as blasphemies.
George Bernard Shaw

A simple consequence of the quantum of action is the impossibility to completely fill a glass of wine. If we call ‘full’ a glass at maximum capacity (including surface tension effects, to make the argument precise), we immediately see that the situation requires complete rest of the liquid’s surface, which the quantum of action forbids. Indeed, a completely quiet surface would allow two subsequent observations which differ by less than $\hbar/2$. In other words, the quantum of action proves the old truth that a glass of wine is always partially empty *and* partially full.

Challenge 609

The quantum of action has many similar consequences for everyday life. For example, a pencil on its tip *cannot* stay vertical, even if it is isolated from all disturbances, such as vibrations, air molecules, and thermal motion. Are you able to confirm this? In fact, it is even possible to calculate the time after which a pencil must have fallen over.*

Challenge 626

But the quantum of action has more important effects. As Table 42 shows, the fundamental processes of material science, of chemistry, and of life have action values around \hbar . Obviously, this is true also for all light emission processes.

All the unexplained effects of classical physics take place in domains where the action is near the minimum observable one. Thus we need quantum theory to understand these

* That is not easy, but neither too difficult. For an initial orientation close to the vertical, the fall time T turns out to be

$$T = \frac{1}{2\pi} T_0 \ln \frac{8}{\alpha} \quad (402)$$

Ref. 21
Challenge 643

where α is the starting angle, and a fall by π is assumed. Here T_0 is the oscillation time of the pencil for small angles. (Can you determine it?)

Challenge 660

Now the indeterminacy relation for the tip of the pencil gives a minimum angle, because the momentum uncertainty cannot be made as large as wanted. You should be able to provide an upper limit. Once the angle is known, you can calculate the maximum time.

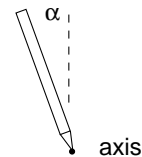

Figure 195 A falling pencil

situations. To start with, we begin the exploration with the study of the motion of a *single* particle. Later on we will briefly expand this to a few situations with a higher number.

Matter particles

Tristo quel discepolo che non avanza il suo maestro.
Leonardo da Vinci*

In the first part of our walk we noticed that perfect rest is never observed. Quantum theory teaches us why.

– CS – more soon – CS –

All flows are made of particles. This statement was deduced from the quantum of action. Two flows ask for direct confirmation: flows of matter, like that of a liquid, and flows of electricity. That matter is made of particles is not new. We mentioned in the first part that a consequence of liquids being made of molecules is that even in the smoothest of pipes, even oil or any other smoothest liquid still produces noise when it flows through the pipe. We mentioned that the noise we hear in our ears in situations of absolute silence, such as in a snowy landscape in the mountains, is due to the granularity of matter.

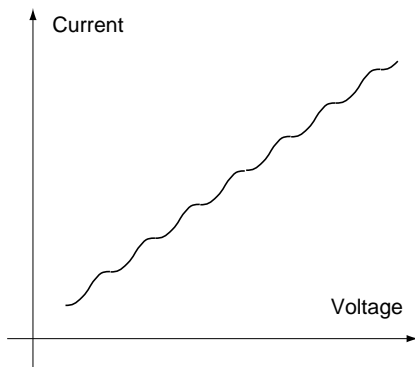

Figure 196 Steps in the flow of electrons
electrons can move freely in metals; that is the reason that metal conduct electric current so well.

The quantum of action also implies that electrical current cannot be a continuous flow; otherwise it would be possible to observe actions as small as desired. The simplest of these experiments was discovered only in the 1990s: Take two metal wires on the table, crossing each other. If one lets current flow from one wire to the other, via the crossover, one finds a curve like the one shown in Figure 196.

Many other experiments confirm the result: there is a *smallest* charge in nature. This smallest charge has the same value as the charge of an electron. Electrons turn out to be part of every atom, in a complex way to be explained shortly. In addition, a number of

Both electrons and atoms are *quantum* particles or *quantons*; they show some of the aspects of everyday particles, but show many other aspects which are different from what is expected from little stones. Let us have a rapid tour. Everyday matter has size, structure, mass, shape, colour, position and momentum. What about matter quantons?

First of all, matter quantons do have mass. Secondly they move in such a way that the quantum of action is respected. Matter quantons, like stones, and in contrast to photons, *can* be localized. However, there is no way to ascribe them a specific momentum and a specific position at the same time. The limits are easily experienced in the single slit experiment.

* Sad is that disciple who does not surpass his master.

– CS – the rest of quantum theory will appear in the next version – CS –

No north pole

The quantum of action has also important consequences for rotational motion. We saw above that due to the quantum of action, in the same way that for every object the momentum is fuzzy, also its angular momentum is. But there is more.

Classically speaking, the poles of the earth are spots which do not move, when seen from a non-rotating observer. Therefore at those spots matter would have a defined position and a defined momentum. However, the quantum of action forbids this. In short, there is no north pole on earth. More exactly, the idea of a *rotation axis* is an approximation not valid in general.

But that is not all that changes about rotation due to the quantum of action. Even more interesting are its effects on microscopic particles, such as atoms, molecules, nuclei, etc. To begin with, one notes that action and angular momentum have the same units. Moreover, if a *microscopic* particle rotates by an angle, this rotation might be unobservable, a situation in fundamental contrast with the case of *macroscopic* objects. Experiments indeed confirm that many microscopic particles have unobservable rotation angles. For example, in many, but not all cases, an atomic nucleus rotated by half a turn cannot be distinguished from the unrotated nucleus.

If a microscopic particle has a *smallest* unobservable rotation angle, the quantum of action implies that the angular momentum of that particle *cannot* be zero. It must always be rotating. Therefore we need to check for each particle what its smallest unobservable angle of rotation is. Experiments provide the following values: 0 , 4π , 2π , $4\pi/3$, π , $4\pi/5$, $2\pi/3$, etc.

Let us take an example. Let us take the mentioned nucleus for which the smallest unobservable rotation angle is *half* a turn. That would be the case for a nucleus that looks like a rugby ball turning around the short axis. Both the largest observable rotation and the uncertainty are thus a *quarter* turn. Since the change of action produced by a rotation is the number of turns times the angular momentum, we find that the angular momentum of this nucleus is $2 \cdot \hbar$.

As a general result we deduce that the angular momentum of a microscopic particle can be 0 , $\hbar/2$, \hbar , $3\hbar/2$, $2\hbar$, $5\hbar/2$, $3\hbar$, etc. In other words, the intrinsic angular momentum of particles, usually called their *spin*, is an integer multiple of $\hbar/2$. Spin describes how a particle behaves under rotations.

How can a electron rotate? At this point we do not know yet how to *picture* the rotation. But we can *feel* it. This is done in the same way we showed that light is made of rotating entities: all matter, including electrons, can be *polarized*. This was show for the first time by the famous Stern-Gerlach experiment. Stern and Gerlach found that that a beam of silver atoms can be spilt into two beams by using an inhomogeneous magnetic field.

Ref. 22

– CS – the rest of quantum theory will appear in the next version – CS –

19. Interactions of light and matter – simple QED

After the description of the motion of matter and radiation, the next step is the description of their interactions. In other words, how do charged particles react to electromagnetic fields and vice versa? There are a number of surprising effects, most of which appear when the problem is treated taking special relativity into account.

What are stars made of?

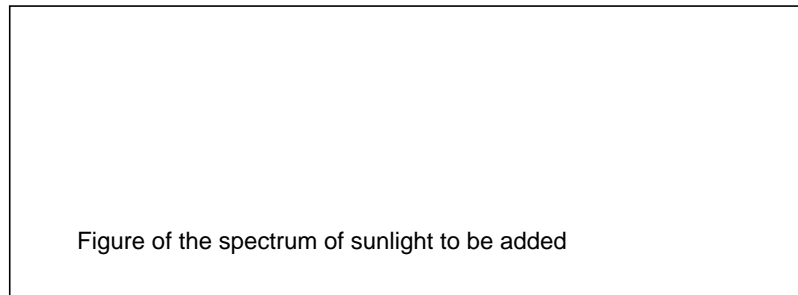

Figure 197 The spectrum of daylight: a section of the rainbow

In the beginning of the eighteenth century the english physicist William Wollaston and again the bavarian instrument maker Joseph Fraunhofer noted that the rainbow misses some colours. These places are called *Fraunhofer lines* today and are used as standards for various measurements. Then in 1860, Gustav Kirchhoff and Robert Bunsen showed that the missing colours were exactly those colours that certain elements emitted when heated. With a little of experimenting they managed to show that sodium, calcium, barium, nickel, magnesium, zinc, copper and iron existed on the sun. They were unable to attribute 13 of the 476 lines they knew. In 1868, Jules Janssen and Joseph Lockyer independently predicted that the lines were from a new element; it was eventually found also on earth, by William Ramsay in 1895. Obviously it is called 'helium', from the greek word 'helios' – sun. Today we know that it is the second ingredient of the sun, in order of frequency, and of the universe, after hydrogen.

Understanding the colour lines produced by each element had started to become of interest already before this discovery; the interest rose even more afterwards, due to the applications of colours in chemistry, physics, technology, crystallography, biology and lasers.

Classical electrodynamics cannot explain the sharp colour lines. Only quantum theory achieved this.

What determines the colour of atoms?

Relativistic wave equations

The equation was more intelligent than I was.
Paul Dirac about his equation

– CS – This section is still missing – CS –

In summary, as far as known today, the relativistic description of the motion of charged matter and electromagnetic fields is *perfect*: no differences between theory and experiment have ever been found, despite intensive searches and despite a high reward for anybody who would find one. All known predictions completely correspond with the measurement results. In the most spectacular cases, this is true with a precision of fourteen digits. But the precision of QED is less interesting than those of its features which are missing in classical electrodynamics. Let's have a quick tour.

Antimatter

Antimatter is now a household term. Interestingly, the term was formed *before* any experimental evidence for it was known. The antimatter companion of the electron was predicted in 1926 by Paul Dirac from his equation. Without knowing this prediction, C.D. Anderson discovered it in 1932 and called it *positron*, even though 'positon', without the 'r', would have been the correct name. Anderson was studying cosmic rays and noticed that some 'electrons' were turning the wrong way in the magnetic field he had applied to his apparatus. He checked everything in his machine and finally deduced that he found a particle with the same mass as the electron, but with positive electric charge.

The existence of positrons has many strange implications. Already in 1928, before their discovery, the swedish theorist Oskar Klein had pointed out that Dirac's equation for electrons makes a strange prediction: when an electron hits a sufficiently steep potential wall, the reflection coefficient is larger than unity. Such a wall will reflect *more* than what is thrown at it. In 1935, after the discovery of the positron, Heisenberg and Euler explained the paradox. They found that the Dirac equation predicts a surprising effect: if an electric field exceeds the critical value of

Ref. 33

$$E_c = \frac{m_e c^2}{e \lambda_e} = \frac{m_e^2 c^3}{e \hbar} = 1.3 \text{ EV/m} \quad , \quad (403)$$

the vacuum will spontaneously generate electron-positron pairs, which then are separated by the field thus reduce it. This so-called *vacuum polarization* is also the reason for the reflection coefficient greater than unity found by Klein, as steep potentials correspond to high electric fields.

Truly gigantic examples of vacuum polarization, namely around charged black holes, will be described later on.

See page 595

We note that such effects show that the *number* of particles is not a constant in the microscopic domain, in contrast to everyday life. Only the *difference* between particle number and antiparticle number turns out to be conserved. This topic will be expanded in the chapter on the nucleus.

Of course, the generation of electron-positron pairs is not a *creation* out of nothing, but a *transformation* of energy into matter. Such processes are part of every relativistic description

of nature. Unfortunately, physicists have the habit to call this transformation ‘creation’, and thus confuse this issue somewhat. Vacuum polarization is a process transforming, as we will see, *virtual* photons into matter. That is not all: the same can also be done with *real* photons.

Transforming light into matter

Everybody who consumes science fiction nowadays knows that matter and antimatter annihilate and transform into pure light. In more detail, a matter particle and an antimatter particle annihilate into two or more photons. More interestingly, quantum theory predicts that the opposite process is also possible: photons hitting photons can produce matter!

Ref. 34 In 1997, this was finally confirmed experimentally. At the Stanford particle accelerator, photons from a high energy laser pulse were bounced off very fast electrons. In this way, the reflected photons had a very large energy when seen in the inertial frame of the experimenter. The original pulse, of 527 nm or 2.4 eV green light, had a peak power density of 10^{22} W/m², about the highest achievable so far. To give an idea, that is a photon density of 10^{34} /m³ and an electric field of 10^{12} V/m, both of which are record values.

Challenge 677 When this laser pulse was reflected of a 46.6 GeV electron beam, the returning photons had an energy of 29.2 GeV and thus had become intense gamma rays. They then collided with the other incoming green photons and produced electron-positron pairs by the reaction

$$\gamma_{29.2} + n \gamma_{\text{green}} \rightarrow e^+ + e^- \quad (404)$$

for which both final particles were detected by special apparatuses. The experiment thus showed that light hitting light is possible in nature, and above all, that doing so can produce matter. This is the nearest one can get to the science fiction idea of light swords or of laser swords banging onto each other.

We will describe a few more successes of quantum theory shortly. Before we do that, we settle one important question.

Compositeness

When is an object composite? Quantum theory gives several practical answers. The first one is somewhat strange: an object is composite when its gyromagnetic ratio g is different than the one predicted by QED. The *gyromagnetic ratio* is defined as

$$g = \frac{2m}{q} \frac{\mu}{L} \quad (405)$$

where μ is the magnetic moment, L the angular momentum, and m and q denote mass and electric charge of the object.

Challenge 694 If this ratio is *different* than the value predicted by QED, about 2.0, the object is *composite*. For example, a ⁴He⁺ helium ion has a spin 1/2 and a g value of $14.7 \cdot 10^3$. Indeed, the radius of the helium ion is $3 \cdot 10^{-11}$ m, finite, and the ion is a composite entity. For the proton, one finds a g value of about 5. Indeed, one measures a proton radius of about 0.9 fm.

Also the neutron, which has a magnetic moment despite being neutral, must therefore be composite. Indeed, its radius is approximately that of the proton. Similarly, molecules, mountains, stars, and people must be composite. Following this first criterion, the only

elementary particles are *leptons* – i.e. electrons, muons, tauons, and neutrinos –, *quarks*, and *intermediate bosons* – i.e. photons, W-bosons, Z-bosons, and gluons. More details on these particles will be uncovered in the chapter on the nucleus.

See page 610

Another simple criterion for compositeness has just been mentioned: *any object with a measurable size is composite*. This criterion is related to the previous one. Indeed, the simplest models for composite structures make the prediction that

Ref. 36

$$g - 2 = \frac{R}{\lambda_C} \quad (406)$$

which is surprisingly precise for helium 4 ions, helium 3, tritium ions, and protons, as you might want to check. This criterion produces the same list of elementary particles as the first.

Challenge 711

A third criterion for compositeness is more general: *any object larger than its Compton length is composite*. The background idea is simple. An object is composite if one can detect *internal motion*, i.e. motion of some components. Now the action of any part with mass m_{part} moving inside a composed system of size r follows

$$S_{\text{part}} < 2\pi r m_{\text{part}} c < \pi r m c \quad (407)$$

where m is the mass of the *composite* object. On the other hand, following the principle of quantum theory, this action, to be observable, must be larger than $\hbar/2$. Inserting this condition, we find that for any composite object*

$$r > \frac{\hbar}{2\pi m c} \quad (408)$$

The right hand side differs only by a factor $4\pi^2$ from the so-called *Compton (wave)length*

$$\lambda = \frac{h}{m c} \quad (409)$$

of an object. Any object *larger* than its own Compton wavelength is thus composite. Any object *smaller* than the right hand side of expression (408) is thus elementary. Again, only leptons, including neutrinos, quarks, and intermediate bosons pass the test. All other objects are composite, as the tables in Appendix C make clear. This third criterion produces the same list as the previous ones. Can you explain the reason?

Challenge 745

Interestingly, the topic is not over yet. Even stranger statements about compositeness will appear when gravity is taken into account. Just be patient; it is worth it.

Curiosities and challenges in quantum theory

Quantum theory is such an interesting topic that all of it could be titled ‘curiosities’. A few of the prettier cases are given here.

Challenge 728 * Can you find the missing factor of 2? And is the assumption valid that the components must always be lighter than the composite?

▪ Can atoms rotate? Can an atom that falls on the floor roll under the table? Can atoms be put into high speed rotation? The answer is no to all questions, because angular momentum is quantized and because atoms are not solid objects. The macroscopic case of an object turning slower and slower until it stops does not exist in the microscopic world. Can you explain how this follows from the quantum of action?

Ref. 37

Challenge 762

▪ Light is diffracted by material gratings. Can matter diffract from light gratings? Surprisingly, it actually can. The effect was predicted by Dirac and Kapitza in 1937. It is hard to see, even for free electrons. The clearest confirmation came in 2001, when the technology advances for lasers were used to perform a beautiful measurement of the typical diffraction maxima for electrons diffracted by a light grating.

Ref. 38

▪ Light is refracted when entering dense matter. Do matter waves behave similarly? Yes, they do. In 1995, David Pritchard showed this for sodium waves entering helium and xenon gas.

Ref. 39

▪ Two observables can commute for two different reasons: either they are very *similar*, such as the coordinate x and x^2 , or they are very *different*, such as the coordinate x and the momentum p_y . Can you give an explanation?

Challenge 779

▪ Do hydrogen atoms exist? Most types of atoms have been imaged with microscopes, photographed under illumination, levitated one by one, and even moved with needles, one by one, as the picture shows. Others have moved single atoms using laser beams to push them. However, no such experiments exist of hydrogen atoms. Is that a reason to doubt the existence of hydrogen atoms? Taking seriously this not-so-serious discussion can be a lot of fun.

Ref. 40

Challenge 796

▪ Space and time translations commute. Why then do the momentum operator and the Hamiltonian not commute in general?

Challenge 813

▪ Small changes in the strength of electromagnetic attraction between electrons and protons would have important consequences. Can you describe what would happen to the size of people, to the colour of objects, to the colour of the sun or to the workings of computers if the strength would double? And if it would drop to half the usual value over time?

Challenge 830

The strength of electromagnetism

The great Wolfgang Pauli used to say that after his death, the first question he would ask would be an explanation of Sommerfeld's fine structure constant. (People used to comment that after the devil will have explained it to him, he will think a little, and then snap 'Wrong!') The name *fine structure constant* was given by Arnold Sommerfeld to the constant

See page 375

$$\alpha = \frac{e^2}{4\pi\epsilon_0\hbar c} \approx \frac{1}{137.03599976(50)} \approx 0.007297352533(27) \quad (410)$$

because it appears in explanations for the fine structure of certain atomic colour spectra. Sommerfeld was the first to understand its importance. The number is central to quantum

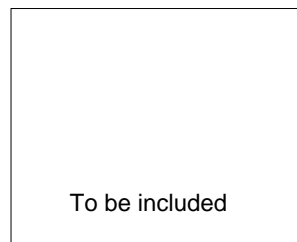

Figure 198 The result of moving atoms one by one on a metal surface

electrodynamics for several reasons. First of all, it describes the *strength* of electromagnetism. Since all charges are multiples of the electron charge, a higher value would mean a stronger attraction or repulsion between charged bodies. The value of α thus determines the size of atoms, and thus the size of all things, as well as all colours.

Secondly, the fact that this number is quite a bit smaller than unity turns out to be the reason that we can talk about particles at all. The argument is somewhat involved; it will be detailed later on. In any case, only the small value of the fine structure constant makes it possible to distinguish particles from each other. If the number were near or larger than one, particles would interact so strongly that it would *not* be possible to observe or to talk about particles at all.

This leads to the third reason that the constant is important. Since the fine structure constant is a dimensionless number, it implies some yet unknown mechanism fixing its value. Uncovering this mechanism is one challenge left over. As long as the mechanism remains unknown, we do not understand the colour and size of a single thing.

Explaining the number is the most famous and the toughest challenge of modern physics since the issue appeared in the 1920s. It is the reason for Pauli's statement cited above. The challenge is so tough that for the first 50 years there were only two classes of physicists: those who did not even dare to take on the challenge, and those who had no clue. This fascinating story still awaits us.

To continue with the highest efficiency on our path through quantum theory, we first look at two important topics: the issue of indistinguishability and the issue of interpretation of its probabilities.



References

- 1 GIUSEPPE FUMAGALLI, *Chi l'ha detto?*, Hoepli, Milano, 1983. Cited on page 480.
- 2 The quantum of action is introduced in MAX PLANCK, ... In his papers, Planck used the letter *b* for what nowadays is called *h*. Cited on page 481.
- 3 For some the rare publications emphasizing the quantum of action see M.B. MENSKY, *The action uncertainty principle in continuous quantum measurements*, Physics Letters A **155**, pp. 229–235, 1991, M.B. MENSKY, Physics Letters A **162**, p. 219, 1992, and M.B. MENSKY, *The action uncertainty principle in continuous quantum measurements*, Physics Letters A **155**, pp. 229–235, 1991.
 There is a large number of general textbooks on quantum theory. The oldest textbooks are obviously German or English. The choice must be left to every reader.
 A famous *conceptual* introduction is JEAN-MARIE LEVY-LEBLOND, ..., translated into English as *Quantics*, ...
 One of the most beautiful books is JULIAN SCHWINGER, *Quantum Mechanics - Symbolism of Atomic Measurements*, ...
 A modern approach with a beautiful introduction is M. SCHUBERT & G. WEBER, *Quantentheorie*, Spektrum Akademischer Verlag, 1993.
 A standard beginner's text is C. COHEN-TANNOUJJI, B. DIU & F. LALOË, *Mécanique*

- quantique I et II*, Hermann, Paris, 1977. It is also available in several translations. Cited on page 481.
- 4 MAX BORN, *Zur Quantenmechanik der Stoßvorgänge (vorläufige Mitteilung)*, *Zeitschrift für Physik* **37**, pp. 863–867, 1926, MAX BORN, *Quantenmechanik der Stoßvorgänge*, *Zeitschrift für Physik* **38**, pp. 803–827, 1926. Cited on page 483.
 - 5 See for example the papers by JAN HILGEOORD, *The uncertainty principle for energy and time*, *American Journal of Physics* **64**, pp. 1451–1456, 1996, and by PAUL BUSCH, *On the time-energy uncertainty reaction, part 1 & 2*, *Foundations of Physics* **20**, pp. 1–43, 1990. A classic is the paper by EUGENE P. WIGNER, *On the time-energy uncertainty reaction*, in ABDUS SALAM & EUGENE P. WIGNER, editors, *Aspects of quantum theory*, Cambridge University Press, 1972. Cited on page 485.
 - 6 R. LOUDON, *Quantum theory of light*, Oxford University Press, 2000. Cited on page 491.
 - 7 F. RIEKE & D.A. BAYLOR, *Single-photon detection by rod cells of the retina*, *Reviews of Modern Physics* **70**, pp. 1027–1036, 1998. They also mention that the eye usually works at photon fluxes between $10^8 / \mu\text{m}^2\text{s}$ (sunlight) and $10^{-2} / \mu\text{m}^2\text{s}$ (starlight). The cones detect, in colour, light intensities in the uppermost 7 or 8 decades, whereas the rods detect, in black and white, the lower light intensities. Cited on page 492, 493.
 - 8 E. FISCHBACH, H. KLOOR, R.A. LANGEL, A.T.Y. LUI & M. PEREDO, *New geomagnetic limit on the photon mass and on long-range forces coexisting with electromagnetism*, *Physical Review Letters* **73**, pp. 514–517, 1994. Cited on page 493.
 - 9 A.H. COMPTON, *The scattering of X-rays as particles*, *American Journal of Physics* **29**, pp. 817–820, 1961. Cited on page 493.
 - 10 R. HANBURY-BROWN & R.Q. TWISS, *Nature* **177**, p. 27, 1956, and R. HANBURY-BROWN & R.Q. TWISS, *Nature* **178**, p. 1046, 1956. Cited on page 497.
 - 11 *Science* 8 September 1995 Cited on page 498.
 - 12 See the summary by P.W. MILONNI, *Answer to question 45: What (if anything) does the photoelectric effect teach us?*, *American Journal of Physics* **65**, pp. 11–12, 1997. Cited on page 499.
 - 13 For a detailed account, See JEFFREY J. PRENTIS, *Poincaré's proof of the quantum discontinuity of nature*, *American Journal of Physics* **63**, pp. 339–350, 1995. The original papers are HENRI POINCARÉ, *Sur la théorie des quanta*, *Comptes Rendus de l'Académie des Sciences (Paris)* **153**, pp. 1103–1108, 1911, as well as HENRI POINCARÉ, *Sur la théorie des quanta*, *Journal de Physique (Paris)* **2**, pp. 5–34, 1912. Cited on page 499.
 - 14 For an introduction to spueezed light, see L. MANDEL, *Non-classical states of the electromagnetic field*, *Physica Scripta T* **12**, pp. 34–42, 1986. Cited on page 499.
 - 15 J. JACOBSON, G. BJÖRK, I. CHANG & Y. YAMAMOTO, *Photonic de Broglie waves*, *Physical Review Letters* **74**, pp. 4835–4838, 1995. The first measurement was published by E.J.S. FONSECA, C.H. MONTEN & S. DE PÁDUA, *Measurement of the de Broglie wavelength of a multiphoton wave packet*, *Physical Review Letters* **82**, pp. 2868–2871, 1995. Cited on page 499.
 - 16 The famous quote on single photon interference is from P.A.M. DIRAC, *The Principles of quantum mechanics*, Oxford University Press, 1947. It is also discussed, somewhat confusely, in the otherwise informative article by H. PAUL, *Interference between independent photons*, *Reviews of Modern Physics* **58**, pp. 209–231, 1986. Cited on page 501.
 - 17 The original paper by Glauber is ... Cited on page 503.
 - 18 R. KIDD, J. AEDINI & A. ANTON, *Evolution of the modern photon*, *American Journal of Physics* **57**, pp. 27–35, 1989, Cited on page 504.

- 19** WOLFGANG TITTEL, J. BRENDEL, H. ZBINDEN & N. GISIN, *Violation of bell inequalities by photons more than 10 km apart*, Physical Review Letters **81**, pp. 3563–3566, 26 October 1998. Cited on page [505](#).
- 20** N. BOHR & L. ROSENFELD, *Zur Frage der Meßbarkeit der elektromagnetischen Feldgrößen*, Mat.-fys. Medd. Danske Vid. Selsk. **12**, p. 8, 1933. The results were later published in English language as N. BOHR & L. ROSENFELD, *Field and charge measurements in quantum electrodynamics*, Physical Review **78**, pp. 794–798, 1950. Cited on page [505](#).
- 21** E.I. BUTIKOV, *The rigid pendulum – an antique but evergreen physical model*, European Journal of Physics **20**, pp. 429–441, 1999. Cited on page [506](#).
- 22** W. GERLACH & O. STERN, *Der experimentelle Nachweis des magnetischen Moments des Silberatoms*, Zeitschrift für Physik **8**, p. 110, 1921. See also the pedagogical explanation by M. HANNOUT, S. HOYT, A. KRYOWONOS & A. WIDOM, *Quantum measurement and the Stern-Gerlach experiment*, American Journal of Physics **66**, pp. 377–379, 1995. Cited on page [509](#).
- 23** LOUIS DE BROGLIE, ... Cited on page .
- 24** M. ARNDT, O. NAIRZ, J. VOS-ANDREAE, C. KELLER, G. VAN DER ZOUW & A. ZEILINGER, *Wave-particle duality of C60 molecules*, Nature **401**, pp. 680–682, 14 October 1999. Cited on page .
- 25** P. CARRUTHERS & M.M. NIETO, *Phase and angle variables in quantum mechanics*, Review of Modern Physics **40**, pp. 411–440, 1968. Cited on page .
- 26** The uncertainty principle for rotational motion is well explained by ... Cited on page .
- 27** The whole bunch of atoms behaves as one single molecule; one speaks of a Bose-Einstein condensate. This was observed e.g. by M.H. ANDERSON & al., *Observation of Bose-Einstein condensation in a dilute atomic vapour*, Science **269**, pp. 198–201, 1995. Cited on page .
- 28** R.H. DICKE & J.P. WITTKER, *Introduction to quantum theory*, Addison-Wesley, Reading, Massachusetts, 1960. Cited on page .
- 29** Y. AHARONOV & D. BOHM, Physical Review **115**, p. 485, 1959. Cited on page .
- 30** K. VON MEYENN & E. SCHUCKING, *Wolfgang Pauli*, Physics Today pp. 43–48, February 2001. Cited on page .
- 31** L.L. FOLDY & S.A. WOUTHUYSEN, *On the Dirac theory of spin 1/2 particles and its non-relativistic limit*, Physical Review **78**, pp. 29–36, 1950. Cited on page .
- 32** JOHN P. COSTELLA & BRUCE H.J. MC KELLAR, *The Foldy-Wouthuysen transformation*, American Journal of Physics **63**, pp. 1119–1121, 1995. Cited on page .
- 33** W. HEISENBERG & ... EULER, ...1935. See also J. SCHWINGER, ...1951. Cited on page [511](#), [583](#).
- 34** D.L. BURKE & al., *Positron production in multiphoton light-by-light scattering*, Physical Review Letters **79**, pp. 1626–1629, 1997. A simple summary is given in BERTRAM SCHWARZSCHILD, *Gamma rays create matter just by plowing into laser light*, Physics Today **51**, pp. 17–18, February 1998. Cited on page [512](#).
- 35** About tachyons, see ... Cited on page .
- 36** The g-factors for composite nuclei are explained by ... See also HANS DEHMELT, *Is the electron a composite particle?*, Hyperfine Interactions **81**, pp. 1–3, 1993. Cited on page [513](#).
- 37** J.P. WOERDMAN, G. NIENHUIS & I. KUSCER, *Is it possible to rotate an atom?*, Optics Communications **93**, pp. 135–144, 1992. We are talking about atoms rotating around their centre of mass; atoms can of course rotate around other bodies, as discussed by M.P. SILVERMAN, *Circular birefringence of an atom in uniform rotation: the classical perspective*, American Journal of Physics **58**, pp. 310–317, 1990. Cited on page [514](#).

- 38** All earlier experimental attempts, especially those performed in the 1980s, for the diffraction of electrons from light were controversial, as explained by H. BATELAAN, *Contemporary Physics* **41**, p. 369, 2000. He and his group then performed the newest and most spectacular experiment mentioned above; it is described in D.L. FREIMUND, K. AFLATOONI & H. BATELAAN, *Nature* **413**, p. 143, 2001. Cited on page [514](#).
- 39** J. SCHMIEDMAYER & al., *Physical Review Letters*, July-August 1995. Cited on page [514](#).
- 40** The nearest to an image of a hydrogen atom is found in A. YAZDANI, *Watching an atom tunnel*, *Nature* **409**, pp. 471–472, 2001. The experiments on Bose-Einstein condensation are also candidates for images of hydrogen atoms. The company Hitachi made a fool of itself in 1992 by claiming in a press release that its newest electron microscope could image hydrogen atoms. Cited on page [514](#).

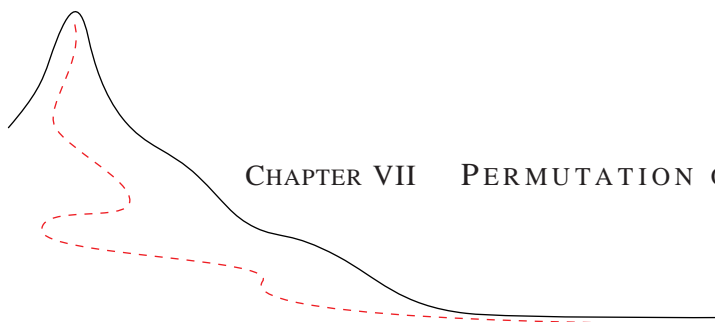

CHAPTER VII PERMUTATION OF PARTICLES

Why are we able to distinguish twins from each other? Why can we distinguish what looks alike, such as a copy from an original? In everyday life, copies always differ somewhat from originals. Think a bout any method you can imagine: you will find that it runs into trouble for point-like particles. We need to study the issue.

Challenge 847

20. Are particles like condoms?

Some usually forgotten properties of objects are highlighted by studying one of the prettiest combinatorial puzzles: the *condom problem*. It asks:

Ref. 1

*How many condoms are necessary if w women want to encounter each of m men in a hygienical way, so that nobody can in fact get in contact with the body fluids of any other?**

The problem appears in many settings. For example, it also applies to doctors, patients and surgical gloves, or to computers, interfaces, and computer viruses. Nevertheless, the way it is formulated here is the most common found in the literature. And obviously, the optimal number of condoms is *not* the product wm . In fact, the problem has three subcases.

- The case $m = w = 2$ already provides the most important ideas needed. Are you able to find the optimal solution and procedure?

Challenge 864

- In the case $w = 1$ and m odd or the case $m = 1$ and w odd, the solution is $(m + 1)/2$ condoms. This is the optimal solution, as you can easily check yourself.

Challenge 881

- A solution with a simple procedure for all other cases is given by $\lceil 2w/3 + m/2 \rceil$ condoms, where $\lceil x \rceil$ means the smallest integer greater than or equal to x . For example, for two men and three women this gives only three condoms. (However, this formula does not always give the optimal solution; better values exist in certain subcases.)

Ref. 2

Challenge 898

Two basic properties of condoms determine the solution. Firstly, condoms have two sides, the interior and the exterior. Secondly, they can be distinguished from each other. Do these two properties also apply to particles? We discuss the first issue in the third part of the mountain ascent, as we are not ready for it yet; the question whether particles can be turned inside out turns out to be of great importance for their description and their motion. In the present chapter we concentrate on the second issue, namely whether particles can always be

See page 662

* This is the conventional formulation; you might want to modify it in various ways depending on your personal preferences.

distinguished. We will find that *elementary* particles do not behave like condoms but behave in an even more surprising manner.

In everyday life, distinction of objects can be achieved in two ways. We are able to distinguish objects – or people – from each other because they differ in their *intrinsic properties*, such as their mass, colour, size or shape. In addition, we are also able to distinguish objects if they have the *same* intrinsic properties. Any game of billiard suggests that by following the path of a ball, we are sure to distinguish objects with identical properties. This second method distinguishes objects using their *state*.

The state of a billiard ball is given by its position and momentum. In the case of billiard balls, distinction is possible because the measurement error for the position of the ball is much smaller than the size of the ball itself. However, in the microscopic domain this is not the case. Obviously, microscopic particles of the same type, such as atoms, have the same intrinsic properties. To distinguish them in collisions, we would be required to keep track of them. But already in the nineteenth century it was shown experimentally that even nature itself is not able to do this. This result was discovered studying systems which incorporate a large number of collisions of atoms of the same type, namely *gases*.

See page 153 The calculation of the entropy of a simple gas, made of N simple particles of mass m moving in a volume V , gives

$$S = k \ln \left[V \left(\frac{mkT}{2\pi\hbar^2} \right)^{3/2} \right]^N + \frac{3}{2}kN + k \ln \alpha \quad (411)$$

where k is the Boltzmann constant and T the temperature. In this formula, the expression α is equal to 1 if the particles are distinguishable, and equal to $1/N!$ if they are not. Measuring the entropy thus allows to determine whether particles are distinguishable. It turns out that only the second case describes nature. This can be seen with a simple test: only in the second case the entropy of two volumes of identical gas adds up. * The result, often called *Gibbs' paradox*, ** thus proves that the microscopic components of matter are *indistinguishable*: in a set of particles, there is no way to say which particle is which. Indistinguishability is an experimental property of nature.

Challenge 915

Ref. 3

The properties of matter would be completely different without indistinguishability. For example, we will discover that without indistinguishability, knives and swords would not cut. In addition, the soil would not carry us; we would fall right through it. *** To illuminate the issue in more detail, let us continue with a related question.

Why does indistinguishability appear in nature?

Challenge 932

* Indeed, the entropy values observed by experiment are given by the so-called Sakur-Tetrode formula

$$S = kN \ln \left[\frac{V}{N} \left(\frac{mkT}{2\pi\hbar^2} \right)^{3/2} \right] + \frac{5}{2}kN \quad (412)$$

which appears when $\alpha = 1/N!$ is inserted above.

** Josiah Willard Gibbs (1839–1903), US-American physicist who was, with Maxwell and Planck, one of the founders of statistical mechanics and thermodynamics; introduced the concepts of *ensemble* and of *phase*.

*** When radioactivity was discovered, people thought that it contradicted the indistinguishability of atoms, as decay seems to single out certain atoms compared to others. Only quantum theory showed that this is not the case, and that atoms remain indistinguishable.

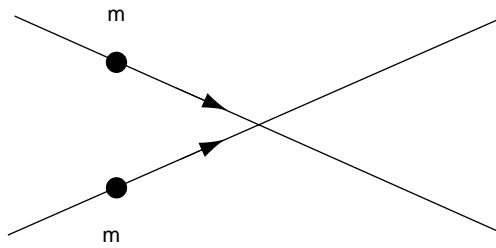

Figure 199 Identical objects with crossing paths of particles moving around and to say which particle is which.

Take two microscopic particles with the same mass, the same composition, and the same shape, such as two atoms. Imagine that their paths cross, and that they approach each other to small distances at the crossing, as shown in Figure 199. Experiments show that at small distances the two particles can switch roles, without anybody being able to avoid it. For example, we saw that in a gas it is *impossible*

Following particles in approaching paths is impossible because at small distances a switch of roles requires only a small amount of change, i.e. a small (physical) action. We know that there is a smallest observable action in nature. However, keeping track of each particles at small distances would require actions *smaller* than the minimal action observed in nature. The existence of a smallest action makes it impossible to keep track of microscopic particles when they come too near to each other.

In short, indistinguishability is a consequence of the existence of a minimal action in nature.

Can particles be counted?

In everyday life, objects can be counted because they can be distinguished. Since quantum particles cannot be distinguished, we need some care in explaining how to count them. The first step is the definition of what is meant by a situation without any particle at all. This seems an easy thing to do, but later on we will encounter situations where already this step runs into difficulties. The first step is thus the *specification of the vacuum*. Any counting method requires that situations with particles be clearly separated from situations without particles.

The second step is the definition of an observable useful for determining particle number. The easiest way is to take one of those quantum numbers which add up under composition, such as electric charge. * Counting is then performed by measuring the total charge and dividing by the unit charge.

This method has several advantages. First of all, it is not important whether particles are distinguishable or not; it works in either case. Secondly, virtual particles are not counted. This is a welcome state of affairs, as we will see, because for virtual particles, i.e. for particles for which $E^2 \neq p^2c^2 + m^2c^4$, there is *no way* to define a particle number anyway.

The other side is that antiparticles count negatively! Also this consequence is a result of the quantum of action. We saw above that the quantum of action implies that particle-antiparticle pairs can be observed in the vacuum at sufficiently high energies. As a result, an antiparticle must count as minus one particle. In other words, any way of counting particles can produce an error due to this effect. In everyday life this limitation plays no role, as there

* In everyday life, weighing a composite of indistinguishable particles, i.e. measuring its mass, even though it does not fulfil the counting procedure, is usually a sufficient method to count them. But the method obviously does not work in the quantum domain, except for simple cases. Can you give at least two reasons, one from special relativity, and one from general relativity?

This is a section of the freely downloadable e-textbook

Motion Mountain

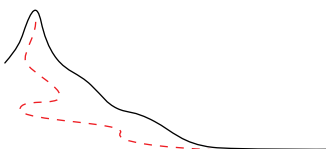

Hiking beyond space and time along the concepts of modern physics

available at
www.motionmountain.org

Copyright © 1997, 1998, 1999, 2000, 2001, 2002 by Christoph Schiller

To the kind reader

In exchange for getting this section for free, I ask you for a short email on some of the following:

- Which page was boring?
- Did you find any mistakes?
- What else were you expecting?
- What was hard to understand?

Of course, any other suggestion is welcome. This section is part of a physics text written over many years. The text lives and grows through the feedback from its readers, who help to improve and to complete it. For a particularly useful contribution (send it in english, italian, dutch, german, spanish, portuguese, or french) you will be mentioned in the foreword of the text, or receive a small reward, or both.

Enjoy!

Christoph Schiller
cs@motionmountain.org

Challenge 949

is no antimatter around us. The issue does play a role at high energies, however. There is thus no way to count the exact number of particles and antiparticles in a physical system. In short, quantum theory shows that there is no perfect way to count particles.

In summary, nature does provide a way to count particles even if they cannot be distinguished, though only for everyday, low energy conditions; due to the quantum of action, antiparticles count negatively, and provide a limit to the counting of particles at high energies.

What is permutation symmetry?

Since particles are indistinguishable but countable, there exists a symmetry of nature for systems composed of several identical particles. *Permutation symmetry*, also called *exchange symmetry*, is the property of nature that observations are unchanged under exchange of identical particles. Together with space-time symmetry, gauge symmetry, and the not yet encountered renormalization symmetry, permutation symmetry forms one of the four pillars of quantum theory. Permutation symmetry is a property of *composed* systems, i.e. of systems made of many (identical) subsystems. Only for such systems indistinguishability plays a role.

In other words, ‘indistinguishable’ is not the same as ‘identical’. Two particles are not the *same*; they are more like *copies* of each other. On the other hand, everyday life experience shows us that copies can be distinguished under close inspection, so that the term is not fully appropriate either. In the microscopic domain, particles are countable and completely indistinguishable.* Particles are perfect copies of each other.

We will discover shortly that permutation is partial rotation. Permutation symmetry thus is a symmetry under partial rotations. Can you find out why?

Challenge 983

Indistinguishability and symmetry

The indistinguishability of particles leads to important conclusions about the description of their state of motion. This happens because it is impossible to formulate a description of motion that includes indistinguishability right from the start. Are you able to confirm this?

Challenge 1000

Therefore we describe a n -particle state with a wavefunction $\Psi_{1\dots i\dots j\dots n}$ which assumes that distinction is possible, as expressed by the ordered indices in the notation, and we introduce the indistinguishability afterwards. Indistinguishability means that the exchange of any two particles leads to the same result. We therefore have the same situation as seen already several times: *an overspecification of the mathematical description*, here the explicit ordering of the indices, *implies a symmetry of this description*, which in our case is a symmetry under exchange of indices, i.e. pairs of particles. Now, two quantum states have the same physical properties if they differ at most by a phase factor; indistinguishability thus requires

$$\Psi_{1\dots i\dots j\dots n} = e^{i\alpha} \Psi_{1\dots j\dots i\dots n} \quad (413)$$

* The word ‘indistinguishable’ is so long that many physicists sloppily speak of ‘identical’ particles nevertheless. Take care.

for some unknown angle α . Applying this expression twice, by exchanging the same couple of indices again, allows us to conclude that $e^{2i\alpha} = 1$. This implies that

$$\Psi_{1\dots i\dots j\dots n} = \pm \Psi_{1\dots j\dots i\dots n} \quad , \quad (414)$$

in other words, a wavefunction is either *symmetric* or *antisymmetric* under exchange of indices. Quantum theory thus predicts that particles are indistinguishable in one of two distinct ways. * Particles corresponding to symmetric wavefunctions are called *bosons*, those corresponding to antisymmetric wavefunctions are called *fermions*. **

Experiments show that the behaviour depends on the *type* of particle. Photons are bosons. Electrons, protons and neutrons are found to be fermions. Also about half of the atoms are found to behave as bosons. In fact, a composite of an *even* number of fermions – or of any number of bosons – turns out to be a boson; a composite of an *odd* number of fermions is a fermion. For example, almost all of the known molecules are bosons. Fermionic molecules are rather special and have even a special name in chemistry; they are called *radicals* and are known for their eagerness to react and form normal bosonic molecules again. Inside the human body, too many radicals can have adverse effects on health; it is well known that vitamin C is important because it is effective in reducing the number of radicals.

To which class of particles do mountains, trees, people, and all other macroscopic objects belong?

Challenge 1017

The energy dependence of permutation symmetry

If experiments force us to conclude that nobody, not even nature, can distinguish any two particles of the same type, we deduce that they do not form two separate entities, but some sort of unity. Our naive, classical sense of particle as a separate entity from the rest of the world is thus an incorrect description of the phenomenon of ‘particle’. Indeed, no experiment can track particles with identical intrinsic properties in such a way that they can be distinguished with certainty. This result has been checked experimentally with all elementary particles, with nuclei, with atoms, and with numerous molecules.

How does this fit with everyday life, i.e. with classical physics? We are able to distinguish electrons by pointing to the wire in which they flow, and we can distinguish our fridge from that of our neighbour. While the quantum of action

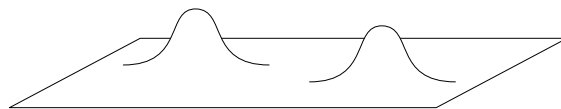

Figure 200 Particles as localized excitations

makes distinction impossible, everyday life allows it. The simplest explanation is to imagine a microscopic particle, especially an elementary one, as a bulge, i.e. as a localized excitation

* This conclusion applies to three-dimensional space only. In two dimensions there are more possibilities.

** The first name is derived from the name of the Italian physicist and Nobel Prize winner Enrico Fermi (1901, Roma–1954, Chicago) famous for his all-encompassing genius in theoretical and experimental physics. He mainly published on nuclear and elementary particle physics, and on spin and statistics. For his experimental work he was called ‘quantum engineer’. He is famous for his lectures, which are still published in his own hand-writing, and his beautiful approach to physical problems. Nevertheless, his highly deserved Nobel Prize was one of the few cases in which the prize was given for a discovery which turned out to be incorrect.

Bosons are named after the Indian physicist Satyenra Nath Bose (1894, Calcutta–1974, Calcutta) who first described the statistical properties of photons, later expanding his work in collaboration with Albert Einstein.

of the vacuum. Figure 200 shows two such bulges representing two particles. It is evident that if particles are too near to each other, it makes no sense to distinguish them; we cannot say anymore which is which.

We conclude that either for large distances or for high potential walls separating them, distinction of identical particles does become possible. In such situations, measurements allowing to track them independently do exist. In other words, we can define an energy at which permutation symmetry of objects or particles separated by a distance d becomes important. It is given by

$$E = \frac{c \hbar}{d} . \quad (415)$$

Challenge 1034

Are you able to confirm the expression? For example, at everyday temperatures we *can* distinguish atoms inside a solid from each other, since the energy so calculated is much higher than the thermal energy of atoms. To have fun, you might want to determine at what energy two truly identical human twins become indistinguishable. Estimating at what energies the statistical character of trees, or fridges will become apparent is then straightforward.

Challenge 1051

The bulge image of particles thus purveys that objects are distinguishable in everyday life even though this is not the case in the microscopic domain. As a result, in daily life we are able to distinguish objects and thus also people for two reasons: because they are made of *many* parts, and because we live in a *low energy* environment.

Challenge 1068

The energy issue immediately brings an additional twist into the discussion. How can we describe fermions and bosons in the presence of virtual particles and of antiparticles?

Indistinguishability in quantum field theory

Quantum field theory, as we will see shortly, simply puts the bulge idea of Figure 200 into mathematical language. A situation with no bulge is called *vacuum state*. Quantum field theory describes all particles of a given type as *excitations* of a single fundamental field. Particles are indistinguishable because they each is an excitation of the same basic substrate with the same properties. A situation with one particle is then described by a vacuum state acted upon by a *creation operator*. Adding a second particle is described by adding a second creation operator, and subtracting a particle by adding a *annihilation operator*; the latter turns out to be the adjunct of the former.

Quantum field theory then studies how these operators must behave to describe observations.* It arrives at the following conclusions:

- Fields with half-integer spin are fermions and imply (local) anticommutation.
- Fields with integer spin are bosons and imply (local) commutation.

* Whenever the relation

$$[b, b^\dagger] = bb^\dagger - b^\dagger b = 1 \quad (416)$$

holds between the creation operator b^\dagger and the annihilation operator b , the operators describe a *boson*. If the operators for particle creation and annihilation anticommute

$$\{d, d^\dagger\} = dd^\dagger + d^\dagger d = 1 \quad (417)$$

they describe a *fermion*. The so defined bracket is called the *anticommutator bracket*.

- For all fields at spacelike separations, the commutator – respectively anticommutator – vanishes.
- Antiparticles of fermions are fermions, and antiparticles of bosons are bosons.
- Virtual particles behave like their real counterparts.

These connections are at the basis of quantum field theory. They describe how particles are identical. But why are they? Why are all electrons identical? Quantum field theory describes electrons as identical excitations of the vacuum, and as such as identical by construction. Of course, this answer is only partially satisfying. We will find a better one only in the third part of our mountain ascent.

How accurately is permutation symmetry verified?

Ref. 4 A simple but effective experiment testing the fermion behaviour of electrons was carried out by Ramberg and Snow. They sent an electric current of 30 A through a copper wire for one month and looked for X-ray emission. They did not find any. They concluded that electrons are always in an antisymmetric state, with a symmetric component of less than

$$2 \cdot 10^{-26} . \quad (418)$$

Electrons are thus fermions.

The reasoning behind this elegant experiment is the following. If electrons would not always be fermions, every now and then an electron could fall into the lowest energy level of a copper atom, leading to X-ray emission. The lack of such X-rays implies that electrons are fermions to a very high accuracy. In particular, two electrons cannot be in the same state; this is the so-called Pauli exclusion principle, our next topic.

Copies, clones, and condoms

Can classical systems be indistinguishable? They can: large molecules are examples – provided they are made of exactly the same isotopes. Can *large* classical systems, made of a mole or more particles be indistinguishable? This simple question is a topic of modern research, as it effectively asks whether a perfect copy, or (physical) *clone* of a system is possible.

It could be argued that any factory for mass-produced goods, such as one producing shirt buttons or paper clips, shows that copies are possible. But the appearance is deceiving.

Ref. 6 In 1982, the Dutch physicist Dennis Dieks and the US-American physicists Wootters and Zurek published simple proofs that quantum systems cannot be copied. Simply stated, if a machine would be able to copy states $|A\rangle$ and $|B\rangle$, it could not decide whether the state $|A+B\rangle$ should be copied into $|A+B\rangle$ or into $|A\rangle + |B\rangle$, as both results must be apply for such a machine, which is necessarily linear.*

Ref. 7 Others explored how precisely an imperfect copy can be produced and what happens in case of classical systems. To make a long story short, these investigations show that copying or cloning macroscopic systems is impossible. In simple words, copy machines do not exist.

* This no-cloning theorem puts severe limitations on quantum computers, as computations often need copies of intermediate results: it makes quantum cryptography possible – at least in principle –, as it is impossible to copy a result without being noticed, and it makes faster-than-light communication impossible in EPR experiments.

Copies can always be distinguished from originals if observations are made with sufficient care. In particular, this is the case for biological clones; biological clones are identical twins born after separate pregnancies. They differ in their finger prints, iris scans, physical and emotional memories, brain structures and in many other aspects. (Can you specify a few more?) Biological clones, like identical twins, are not copies of each other.

Challenge 1085

In summary, everyday life objects such as billiard balls, twins or condoms are always distinguishable. There are two reasons: firstly, quantum effects play no role in everyday life, so that there is no danger of unobservable exchange; secondly, perfect clones of classical systems do not exist anyway, so that there always are tiny differences between any two similar looking objects. Condoms can always be distinguished.

21. Rotations and statistics – visualizing spin

We saw above that spin is the observation that matter beams, like light beams, can be polarized. Spin thus describes how particles behave under rotations, and it proves that particles are not spheres shrunk to points. We also saw that spin describes a difference between quantum systems and condoms: spin specifies the indistinguishability of quantum systems. Let us explore this connection in more detail.

The general background for the appearance of spin was elucidated by Eugene Wigner in 1939.* He started by recapitulating that any quantum mechanical particle, if elementary, must behave like an irreducible representation of the set of all viewpoint changes. This set forms the symmetry group of flat space-time, the so-called *inhomogeneous Lorentz group*. We have seen in the chapter on classical mechanics how the connection between elementarity and irreducibility arises. To be of physical relevance for quantum theory, representations also have to be *unitary*. The full list of irreducible unitary representations of viewpoint changes thus provides the range of possibilities for any particle that wants to be *elementary*.

Ref. 8

Cataloguing the possibilities, one finds first of all that every elementary particle is described by four-momentum – no news so far – and by an internal angular momentum, the *spin*. The four-momentum results from translation symmetry of nature, and the spin from its rotation symmetry. The momentum value describes how a particle behaves under translation, i.e. under position and time shift of viewpoints. The spin value describes how an object behaves under rotations in three dimensions, i.e. under orientation change of viewpoints.** As is well known, the magnitude of four-momentum is an invariant property, and is given by the mass, whereas its orientation in space-time is free. Similarly, the magnitude of spin is an invariant property, and its orientation has various possibilities with respect to the direction of motion. In particular, the spin of massive particles behaves differently from that of massless particles.

See page 130

For *massive* particles, the inhomogeneous Lorentz group implies that there is an invariant value $\sqrt{J(J+1)}\hbar$, often simply written J , of this internal angular momentum. The value specifies the magnitude of the angular momentum, and thus gives the representation under

* Eugene Wigner (1902, Budapest–1995), hungarian-American theoretical physicist, Nobel prize for physics in 1939. He wrote over 500 papers, many about symmetry in physics. He was also famous for being the most polite physicist in the world.

** The group of physical rotations is also called $SO(3)$, since it is equivalent to the group of Special Orthogonal 3 by 3 matrices.

rotations of a given particle type. The value of J can be any multiple of $1/2$, i.e. it can take the values $0, 1/2, 1, 3/2, 2, 5/2$, etc. Experiments show that electrons, protons and neutrons have spin $1/2$, the W and Z particles spin 1 , and helium atoms spin 0 . The representation of spin J is $2J + 1$ dimensional, meaning that the orientation of the spin has $2J + 1$ possible values. For electrons there are thus two possibilities; they are usually called ‘up’ and ‘down’.

Spin thus only takes *discrete* values. This is in contrast with linear momentum, whose representations are infinite dimensional, and whose possible values form a *continuous* range.

Also *massless* particles are characterized by the value of their spin. It can take the same values as in the massive case. For example, photons and gluons have spin 1 . For massless particles, the representations are one-dimensional, so that massless particles are completely described by their *helicity*, defined as the projection of the spin onto the direction of motion. Massless particles can have positive or negative helicity, often also called right-handed and left-handed. There is no other freedom for the orientation of spin in the massless case.

The symmetry investigations lead to the classification of particles by their mass, their momentum, and their spin. To complete the list, the remaining symmetries must be included. These are motion inversion parity, spatial parity and charge inversion parity. Since these symmetries are parities, each elementary particle has to be described by three additional numbers, called T, C, and P, each of which can take values of either $+1$ or -1 . Being parities, they must be *multiplied* to yield the value for a composed system.

See page 827

A list of the values observed for all elementary particles in nature is given in Appendix C. Spin and parities together are called *quantum numbers*. As we will discover later, additional interaction symmetries will lead to additional quantum numbers. But let us return to spin.

The main result is that spin $1/2$ is a possibility in nature, even though it does not appear in everyday life. Spin $1/2$ means that only a rotation of 720 degrees is equivalent to one of 0 degrees, while one of 360 degrees is not, as explained in Table 454. The mathematician Hermann Weyl used a simple image explaining this connection.

Take two cones with their tips together, and touching each other along a line. Hold one cone and roll the other around it. When the rolling cone has come back to the original position, it has rotated by some angle. If the cones are wide, the rotation angle is small. If the cones are very thin, almost like needles, the moving cone has rotated by almost 720 degrees. A rotation of 720 degrees is thus similar to one by 0 degrees.

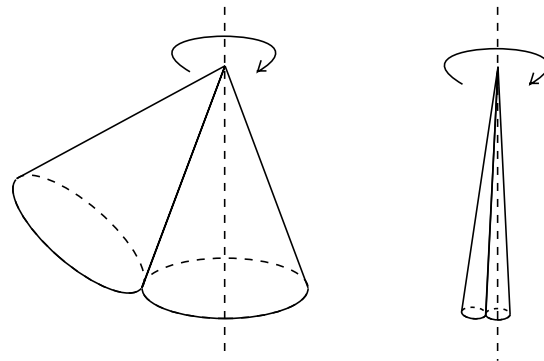

Figure 201 An argument showing why rotations by 4π are equivalent to no rotation

To sum up, the list of possible representations thus shows that rotations *require* the existence of spin. But why then do experiments show that all fermions have half-integer spin, and all bosons have integer spin? Why do electrons obey the Pauli exclusion principle? At first, it is not clear what the spin has to do with the statistical properties of a particle.

Spin	system unchanged after rotation by	massive elementary examples	massive composite examples	massless elementary examples
0	any angle	none ^{a,b}	mesons, nuclei, atoms	none ^b
1/2	2 turns	e, μ , τ , q	nuclei, atoms, molecules	ν_e , ν_μ , ν_τ
1	1 turn	W, Z	mesons, atoms, molecules, toasters	g, γ
3/2	2/3 turn	none ^b	baryons, atoms	none ^b
2	1/2 turn	none	nuclei	'graviton' ^c
5/2	2/5 turn	none	nuclei	none
3	1/3 turn	none	nuclei ^d	none
etc. ^d				

a. Whether the Higgs particle is elementary or not is still unknown.

b. Supersymmetry predicts particles in these and other boxes.

c. The graviton has not yet been observed.

d. Nuclei exist with spins values up to at least $101/2$ and 51 . Ref. 10

Table 43 Irreducible representations of the rotation group

In fact, there are several ways to show that rotations and statistics are connected. Historically, the first proof used the details of quantum field theory, and was so complicated that its essential ingredients are hidden. It took quite some years to convince everybody that a simple observation about belts was the central part of the proof. Ref. 9

The belt trick

The well-known *belt trick* was often used by Dirac to explain the features of spin $1/2$. Taking Figure 200, which models particles as indistinguishable excitations, it is not difficult to imagine a sort of sheet connecting them, similar to a belt connecting the two parts of the buckle, as shown in Figure 202. If one end of the belt is rotated by 2π along any axis, a twist is inserted into the belt. If the end is rotated for another 2π , bringing the total to 4π , the ensuing double twist can easily be undone without moving or rotating the ends. You need to experience this yourself in order to believe it.

Challenge 1102

In addition, if you take the two ends and simply *swap* positions, a twist is introduced into the belt. Again, a second swap will undo the twist.

In other words, if we take each end to represent a particle, and a twist to mean a factor -1 , the belt exactly describes the phase behaviour of spin $1/2$ wavefunctions under exchange and under rotations. In particular, we see that spin and exchange behaviour are related.

The human body has such a belt built in: the *arm*. Just take your hand, put an object on it for clarity, and turn the hand and object by 2π by twisting the arm. After a second rotation the whole system will be untangled again.

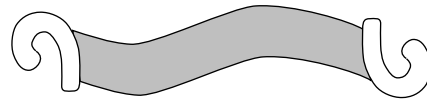

Figure 202 A belt visualizing spin 1/2

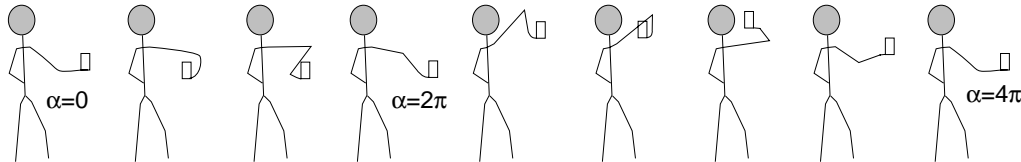

Figure 203 The human arm as spin 1/2 model

The trick is even more impressive when many tails are used. In fact, there are two ways to do this.

One way is connect two buckles with *many* bands or threads, like in Figure 204. Both a rotation by 2π of one end or an exchange of both ends produces quite a tangle; still, in both cases a second operation leads back to the original situation.

There is a second, even more interesting way to show the connection between rotation and exchange. Just glue any number of threads or bands, say half a meter long, to two asymmetric objects. Like the arm of a human being, the bands are supposed to go to infinity and be attached there. If any of the objects, which represent the particles, is rotated by 2π , twists appear in its strings. If the object is rotated by an additional turn, to a total of 4π , as shown in Figure 205, all twists and tangles can be made to disappear, without moving or turning the object. You really have to experience this in order to believe it. And the trick really works with *any* number of bands glued to the object.

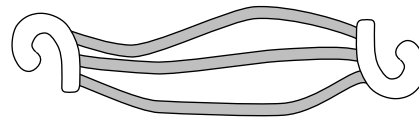

Figure 204 Another spin 1/2 model

Even more astonishing is the other half of the experiment. Take *two* particles as shown in the left of Figure 205. If you exchange the positions of two such spin 1/2 particles, always keeping the ends at infinity fixed, a tangled mess is created. But incredibly, if you exchange the objects a second time, everything untangles neatly, independently of the number of attached strings. You might want to test yourself that the behaviour is still the same with sets of three or more particles.

All these observations together form the spin statistics theorem for spin 1/2 particles: *spin and exchange behaviour are related*. Indeed, these almost ‘experimental’ arguments can be put into exact mathematical language by studying the behaviour of the configuration space of particles. These investigations result in the following statements:

- ▷ *Objects of spin 1/2 are fermions.* *
- ▷ *Exchange and rotation of spin 1/2 particles are similar processes.*

* A mathematical observable behaving like a spin 1/2 particle is neither a vector nor a tensor, as you may want to check. An additional concept is necessary; such an observable is called a *spinor*.

Challenge 1119

Ref. 11

Challenge 15

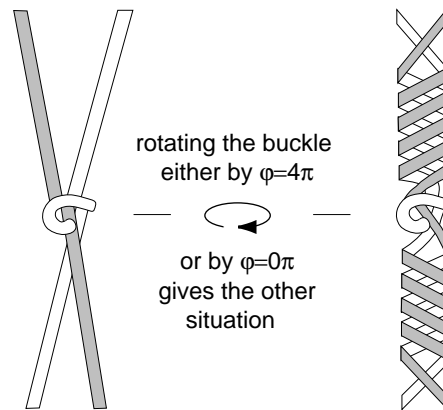

Figure 205 The extended belt trick, modelling a spin 1/2 particle: the two situations can be transformed into each other either by rotating the central object by 4π or by keeping the central object fixed and moving the bands around it

Note that all these arguments only work in three dimensions, because there are no tangles (or knots) in more or fewer dimensions.* And indeed, spin exists only in three spatial dimensions.

Pauli's exclusion principle

Why do fermions obey the Pauli exclusion principle? The answer can be given with a beautifully simple argument. We know that exchanging two fermions produces a minus sign. Imagine these two fermions being, as a classical physicist would say, at the same spot, or as a quantum physicist would say, in the same state. If they could, an exchange would change nothing in the system. But exchange of fermions must produce a minus sign. Both possibilities – no change at all as well as a minus sign – cannot be realized at the same time. There is only one way out: two fermions must avoid to ever be in the same state.

Ref. 12

The exclusion principle is the reason that two pieces of matter in everyday life cannot penetrate each other, but have to repel each other. For example, bells only work because of the exclusion principle. The electrons in the atoms of two interpenetrating pieces would have to be in similar states. This is forbidden. For the same reason we do not fall through the floor, even though gravity pulls us down, but remain on the surface. The exclusion principle also implies that matter cannot be compressed indefinitely, as at a certain stage an effective Pauli pressure provides the limit. For this reason for example, planets or neutron stars do not collapse.

The exclusion principle also answers the question about how many angels can dance on the top of a pin. (Note that angels must be made of fermions, as you might want to deduce from the information known about them.) Both theory and experiment confirm the answer

Challenge 32

*Of course, knots and tangles do exist in higher dimensions, if one does not study strings, but higher-dimensional planes. For examples, deformable planes can be knotted in four dimensions or deformable 3-spaces in five dimensions.

Ref. 5 already given by Thomas Aquinas in the middle ages: only one. The fermion exclusion principle could also be called ‘angel exclusion principle’. To stay in the topic, the principle also shows that *ghosts* cannot be objects, as ghosts are supposed to be able to traverse walls.

Whatever the interpretation, the exclusion principle keeps things in shape; without it, there would be no three-dimensional objects.

Since permutation properties and spin properties are so well described by the belt model, we could be led to the conclusion that they might really be consequence of such belt-like connections between particles and the outside world. Maybe for some reason we only observe the belt buckles, not the belts themselves. In the third part of this walk we will discover whether this idea is correct.

Challenge 49

So far, we have only considered spin $1/2$ particles. We will not talk much about systems with odd spin of higher value, such as $3/2$ or $5/2$. Such systems can be seen as composed of spin $1/2$ entities. Can you confirm this?

We did not talk about lower spins than $1/2$ either. A famous theorem states that a spin value lower than $1/2$ is impossible, because the largest angle that can be measured in three dimensions is 4π . There is no way to measure a larger angle; * thus there cannot be any spin value between 0 and $1/2$.

Integer spin

Integer spin particles behave differently under rotations. They do not show the strange sign changes under rotations by 2π . In the belt imagery, integer spin particles need no attached strings. The spin 0 particle obviously corresponds to a sphere. Models for other spin values are shown in Figure 206. Including their properties in the same way as above, we arrive at the so-called *spin-statistics theorem*:

- ▷ Exchange and rotation of objects are similar processes.
- ▷ Objects of half-integer spin are fermions. They obey the Pauli exclusion principle.
- ▷ Objects of integer spin are bosons.

Challenge 66

You might prove by yourself that this suffices to show that

- ▷ Composites of bosons, as well as composites of an even number of fermions, are bosons; composites of an uneven number of fermions are fermions. **

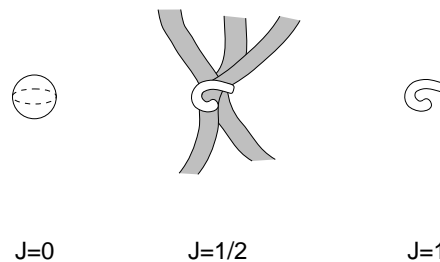

These connections express basic characteristics of the three-dimensional world in which we live.

Figure 206 Some visualizations of spin representations

* This is possible in two dimensions though.

Challenge 83

** This sentence implies that spin 1 and higher can also be achieved *with* tails; can you find such a representation?

Note that composite fermions can be bosons only up to that energy for which the composition breaks down.

Is spin a rotation about an axis?

The spin of a particle behaves experimentally like an intrinsic angular momentum, adds up like angular momentum, is conserved as part of angular momentum, is described like angular momentum, and has a name synonymous with angular momentum. Despite all this, a strange myth was spread in physics courses and textbooks around the world, namely that spin $1/2$ is *not* a rotation about an axis. The myth maintains that any rotating object must have integer spin. Since half integer spin is not possible in classical physics, it is argued that such spin is not due to rotation. It is time to finish with this example of muddled thinking.

Electrons do have spin $1/2$, and are charged. Electrons and all other charged particles with spin $1/2$ do have magnetic momentum.* Magnetic momentum is expected for any rotating charge. In other words, spin $1/2$ does behave like rotation. However, assuming that a particle consists of a continuous charge distribution in rotational motion gives the wrong value for the magnetic momentum. In the early days of the twentieth century, when physicists were still thinking in classical terms, they concluded that spin $1/2$ particles thus cannot be rotating. This myth has survived through many textbooks. The correct deduction though is that the assumption of continuous charge distribution is wrong. Indeed, charge is quantized; nobody today expects that elementary charge is distributed in space, as that would contradict its quantization.

Let us remember what rotation is. Both the belt trick for spin $1/2$ as well as the integer spin case remind us: a *rotation* of one body around another is a fraction or a multiple of an exchange. What we call a rotating body in everyday life is a body continuously exchanging the positions of its parts. Rotation and exchange are the same.

Above we found that spin is exchange behaviour. Since rotation is exchange and spin is exchange, it follows that spin *is* rotation. Since we deduced, like Wigner, spin from rotation invariance, this is not a surprise.

The belt model of a spin $1/2$ particle tells us that such a particle can rotate continuously without any hindrance. In short, we can indeed maintain that spin is rotation about an axis, without any contradiction to observations, even for spin $1/2$. It helps to keep two things in mind: we must assume that in the belt model only the buckles can be observed and do interact, not the belts, and we must assume that elementary charge is pointlike and cannot be distributed.**

Challenge 117

Ref. 13

Why is fencing with laser beams impossible?

When a sword is approaching dangerously, we can stop it with a second sword. Many old movies use such scenes. When a laser beam is approaching, it is impossible to fend it off with a second beam, despite all science fiction movies showing so. Banging two laser beams against each other is impossible.

Challenge 100

* This can easily be measured in a an experiment; however, not one of the Stern-Gerlach type. Why?

** Obviously, the detailed structure of the electron still remains unclear at this point. Any angular momentum S is given classically by $S = \Theta\omega$; however, neither the moment of inertia Θ , connected to the rotation radius and electron mass, nor the angular velocity ω are known at this point. We have to wait quite a while, until the third part of our adventure, to find out more.

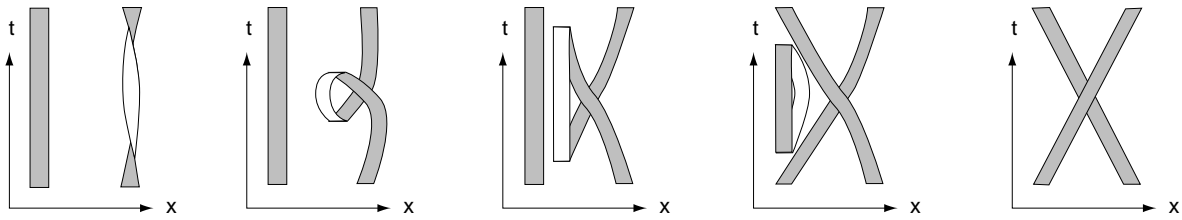

Figure 208 Belts in space-time: rotation and antiparticles

The above discussion shows why. The electrons in the swords are fermions and obey the Pauli exclusion principle. Fermions make matter impenetrable. On the other hand, photons are bosons. Bosons can be in the same state; they allow penetration. Matter is impenetrable because at the fundamental level it is composed of fermions. Radiation is composed of bosons. The distinction between fermions and bosons thus explains why objects can be touched while images cannot. In the first part of our mountain ascent we started by noting this difference; now we know its origin.

See page 59

Rotation requires antiparticles

The connection between rotation and antiparticles may be the most astonishing conclusion from the experiments showing the existence of spin. So far, we have seen that rotation requires the existence of spin, that spin appears when relativity is introduced into quantum theory, and that relativity requires antimatter. Taking these three statements together, the conclusion of the title is not surprising any more. Interestingly, there is a simple argument making the same point directly, without any help of quantum theory, when the belt model is extended from space alone to full *space-time*.

See page 194

To learn how to use it, let us take a particle spin 1, i.e. a particle looking like a detached belt buckle in three dimensions. When moving in a 2+1 dimensional space-time, it is described by a ribbon. Playing around with ribbons in space-time, instead of belts in space, provides many interesting conclusions. For example, Figure 207 shows that wrapping a rubber ribbon around the fingers can show that a rotation of a body by 2π in presence of a second one is the same as exchanging the positions of the two bodies.* Both sides of the hand transform the same initial condition, at a border of the hand, to the same final condition at the other border. We have thus successfully extended a known result from space to space-time. Interestingly, we can find a smooth sequence of steps realizing this equivalence.

Challenge 134

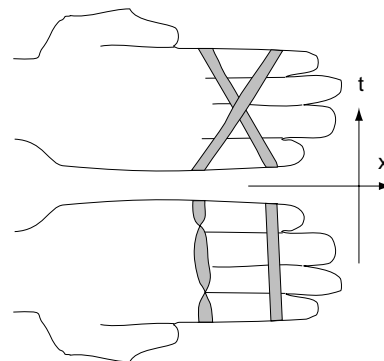

Figure 207 Equivalence of exchange and rotation in space-time

* Obviously, the next step would be to check the full spin 1/2 model of Figure 205 in four-dimensional space-time. But this is not an easy task; there is no generally accepted solution yet.

Challenge 151

When particles in space-time are described as ribbons, Figure 208 shows the intermediate steps allowing to identify a rotation with an exchange. The sequence requires the use of a particle-antiparticle pair. Without antiparticles, the equivalence of rotation and exchange would not hold in space-time. Rotation in space-time requires antiparticles.

Limits and open questions

The topic of statistics is an important research field in theoretical and experimental physics. In particular, researchers have searched and still are searching for generalizations of the possible exchange behaviours of particles.

In two spatial dimensions, the result of an exchange of the wavefunction is not described by a sign, but by a continuous phase. Such objects, called *anyons* because they can have ‘any’ spin, have experimental importance, since in many experiments in solid state physics the set-up is effectively two-dimensional. The fractional quantum Hall effect, perhaps the most interesting discovery of modern solid state physics, has pushed anyons onto the stage of modern research.

Other theorists generalized the concept of fermions in other ways, introducing parafermions, parabosons, plektons and other hypothetical concepts. O.W. Greenberg has spent most of his professional life on this issue. His conclusion is that in $3 + 1$ space-time dimensions, only fermions and bosons exist. (Can you show that this implies that *ghosts* appearing in scottish tales do not exist?)

See page 574

Ref. 14

Challenge 168

From a different viewpoint, the above belt model invites to study the behaviour of braids and knots. (In mathematics, a *braid* is a knot extending to infinity.) This fascinating part of mathematical physics has become important with the advent of string theory, which states that particles, especially at high energies, are not point-like, but extended entities.

Still another generalization of statistical behaviour at high energies is the concept of quantum group, which we will encounter later on. In all of these cases, the quest here is to understand what happens to permutation symmetry in a unified theory of nature. A glimpse of the difficulties appears already above: how can Figures 200, 205 and 208 be reconciled? We will settle this issue in the third part of our mountain ascent.



References

- 1 See the paper by MARTIN GARDNER, *Science fiction puzzle tales*, Clarkson Potter, 67, pp. 104–105, 1981, or his book *aha! Insight*, Scientific American & W.H. Freeman, New York, 1978. The rabbit story is from A. HAJNAL & P. LOVÁSZ, *An algorithm to prevent the propagation of certain diseases at minimum cost*, in *Interfaces between computer science and operations research*, edited by J.K. LENSTRA, A.H.G. RINNOOY KAN & P. VAN EMDE BOAS, Mathematisch Centrum, Amsterdam 1978, whereas the computer euphemism is used by A. ORLITZKY & L. SHEPP, *On curbing virus propagation*, Technical memorandum, Bell Labs 1989. Cited on page 519.

- 2 A complete discussion of the problem can be found in chapter 10 of ILAN VARDI, *Computational Recreations in Mathematics*, Addison Wesley, Redwood City, California, 1991. Cited on page 519.
- 3 On Gibbs' paradox, see your favourite text on thermodynamics or statistical mechanics. See also W.H. ZUREK, *Algorithmic randomness and physical entropy*, Physical Review A **40**, pp. 4731–4751, 1989. Zurek shows that the Sakur-Tetrode formula can be derived from algorithmic entropy considerations. Cited on page 520.
- 4 The experiment is described in E. RAMBERG & G.A. SNOW, Physics Letters B **238**, pp. 438–441, 1990. Other experimental tests are reviewed in O.W. GREENBERG, *Particles with small violations of Fermi or Bose statistics*, Physical Review D **43**, pp. 4111–4120, 1991. Cited on page 526.
- 5 The issue is treated in his *Summa Theologica*, in question 52 of the first part. The complete text, several thousand pages, can be found on the <http://www.knight.org/advent> web site. Cited on page 532.
- 6 The original no-cloning theorem is by D. DIEKS, *Communication by EPR devices*, Physics Letters A **92**, pp. 271–272, 1982, and by W.K. WOOTTERS & W.H. ZUREK, *A single quantum cannot be cloned*, Nature **299**, pp. 802–803, 1982. The whole topic has been presented in detail by V. BUZEK & M. HILLERY, *Quantum cloning*, Physics World **14**, pp. 25–29, November 2001. Cited on page 526.
- 7 The most recent experimental and theoretical results on physical cloning are described in A. LAMAS-LINARES, C. SIMON, J.C. HOWELL & D. BOUWMEESTER, *Experimental quantum cloning of single photons*, Science **296**, pp. 712–714, 2002, D. COLLINS & S. POPESCU, *A classical analogue of entanglement*, preprint [arXiv:quant-ph/0107082](https://arxiv.org/abs/quant-ph/0107082), 2001, and A. DAFFERTSHOFER, A.R. PLASTINO & A. PLASTINO, *Classical no-cloning theorem*, Physical Review Letters **88**, p. 210601, 2002. Cited on page 526.
- 8 E. WIGNER, *On unitary representations of the inhomogeneous Lorentz group*, Annals of Mathematics **40**, pp. 149–204, 1939. This famous paper summarizes the work which later brought him the Nobel Prize for physics. Cited on page 527.
- 9 WOLFGANG PAULI, ..., ... Cited on page 529.
- 10 For a full list of isotopes, see R.B. FIRESTONE, *Table of Isotopes, Eighth Edition, 1999 Update*, with CDROM, John Wiley & Sons, 1999. Cited on page 529.
- 11 M.V. BERRY & J.M. ROBBINS, *Indistinguishability for quantum particles: spin, statistics, and the geometric phase*, Proceedings of the Royal Society in London A **453**, pp. 1771–1790, 1997. See also the comments to this result by J. TWAMLEY, *Statistics given a spin*, Nature **389**, pp. 127–128, 11 September 1997. Cited on page 530.
- 12 R.W. HARTUNG, *Pauli principle in Euclidean geometry*, American Journal of Physics **47**, pp. 900–910, 1979. Cited on page 531.
- 13 The point that spin can be seen as a rotation was already made by F.J. BELINFANTE, *Physica* **6**, p. 887, 1939, and taken up again by HANS C. OHANIAN, *What is spin?*, American Journal of Physics **54**, pp. 500–505, 1986. See also E. DURAN & A. ERSCHOW, *Physikalische Zeitschrift der Sowjetunion* **12**, p. 466, 1937. Cited on page 533.
- 14 Generalizations of bosons and fermions are reviewed in the (serious!) paper by O.W. GREENBERG, D.M. GREENBERGER & T.V. GREENBERGEST, *(Para)bosons, (para)fermions, quons and other beasts in the menagerie of particle statistics*, preprint hep-th/9306225, 1993. A newer summary is O.W. GREENBERG, *Theories of violation of statistics*, preprint hep-th/0007054, 2000. Cited on page 535.



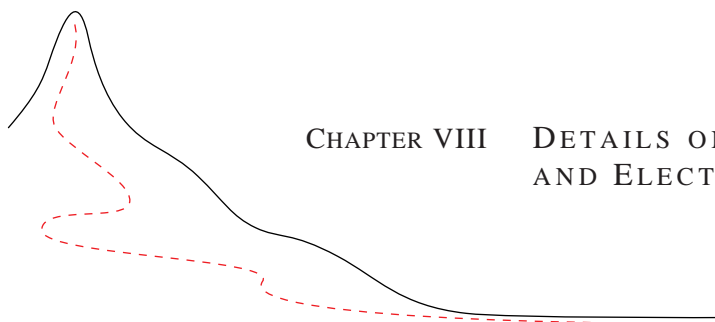

CHAPTER VIII DETAILS ON QUANTUM THEORY AND ELECTROMAGNETISM

22. Superpositions and probabilities – quantum theory without ideology

Niels Bohr brainwashed a whole generation of physicists into believing that the problem [of the interpretation of quantum mechanics] had been solved fifty years ago.
Murray Gell-Mann, Nobel price acceptance speech.

Why is this famous physical issue arousing such strong emotions? In particular, who is brainwashed, Gell-Mann, the discoverer of the quarks, or most of the other physicists working on quantum theory who follow Niels Bohr's* opinion?

In the twentieth century, quantum mechanics has thrown many in disarray. Indeed, it radically changed the two most basic concepts of classical physics: state and system. The *state* is not described any more by the specific values taken by position and momentum, but by the specific wavefunction 'taken' by the position and momentum operators.** In addition, in classical physics a *system* was described as a set of permanent aspects of nature; permanence was defined as negligible interaction with the environment. Quantum mechanics shows that this definition has to be modified as well.

In order to clarify the issues, we take a short walk around the strangest aspects of quantum theory. The section is essential if we want to avoid getting lost on our way to the top of motion mountain, as happened to quite a number of people since quantum theory appeared.

Why are people either dead or alive?

The evolution equation of quantum mechanics is linear in the wavefunction; thus we can imagine and try to construct systems where the state ψ is a superposition of two very distinct situations, such as those of a dead and of a living cat. This famous fictional animal is called *Schrödinger's cat* after the originator of the example. Is it possible to produce it? How

* Niels Bohr (1885, Copenhagen–1962) made his university, Copenhagen, into one of the centres of quantum theory, overshadowing Göttingen. He developed the description of the atom with quantum theory, for which he received the 1922 Nobel prize in physics. He had to flee Denmark in 1943 after the German invasion, because of his Jewish background, but returned there after the war.

** It is equivalent, but maybe conceptually clearer, to say that the state is described by a complete set of commuting operators. In fact, the discussion is somewhat simplified in the Heisenberg picture. However, here we study the issue in the Schrödinger picture, using wavefunctions.

would it evolve in time? Similarly, we can ask for the evolution of the superposition of a state where a car is inside a closed garage with a state where it is outside the closed garage.

All these situations are not usually observed in everyday life. What can be said about them? The answer to these questions is an important aspect of what is often called the ‘interpretation’ of quantum mechanics. In principle, such strange situations are possible, and the superposition of macroscopically distinct states has actually been observed in a few cases, though not for cats, people or cars. To get an idea of the constraints, let us specify the situation in more detail.* The object of discussion are linear superpositions of the type $\psi = a\psi_a + b\psi_b$, where ψ_a and ψ_b are macroscopically distinct states of the system under discussion, and where a and b are some complex coefficients. States are called *macroscopically distinct* when each state corresponds to a different macroscopic situation, i.e. when the two states can be distinguished using the concepts or measurement methods of classical physics. In particular, this means that the physical action necessary to transform one state into the other must be much larger than \hbar . For example, two different positions of any body composed of a large number of molecules are macroscopically distinct.

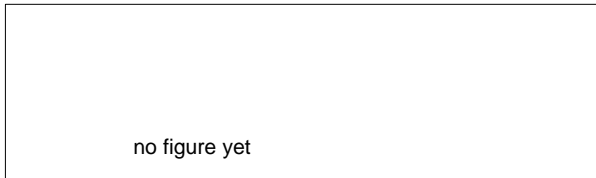

Figure 209 Artist’s impression of a macroscopic superposition

In the case of a superposition of macroscopically distinct states, the scalar product $\psi_a^\dagger \psi_b$ is obviously vanishing. In case of a coherent superposition, the coefficient product a^*b is different from zero. This fact can also be expressed with help of the *density matrix* ρ of the system, defined as $\rho = \psi \otimes \psi^\dagger$. In the present case it is given by

$$\begin{aligned} \rho_{\text{pure}} = \psi \otimes \psi^\dagger &= |a|^2 \psi_a \otimes \psi_a^\dagger + |b|^2 \psi_b \otimes \psi_b^\dagger + a b^* \psi_a \otimes \psi_b^\dagger + a^* b \psi_b \otimes \psi_a^\dagger \\ &= (\psi_a, \psi_b) \begin{pmatrix} |a|^2 & a b^* \\ a^* b & |b|^2 \end{pmatrix} \begin{pmatrix} \psi_a^\dagger \\ \psi_b^\dagger \end{pmatrix} . \end{aligned} \quad (419)$$

We can then say that whenever the system is in a pure state, its density matrix, or *density functional*, contains off-diagonal terms of the same order of magnitude as the diagonal ones.** Such a density matrix corresponds to the above-mentioned situations so contrasting with daily life experience.

- * Most what can be said about this topic has been said by two people: John von Neumann, who in the nineteen thirties stressed the differences between evolution and decoherence, and by Hans Dieter Zeh, who in the nineteen seventies stressed the importance of baths in this process.

** Using the density matrix, we can rewrite the evolution equation of a quantum system:

$$\dot{\psi} = -iH\psi \quad \text{becomes} \quad \frac{d\rho}{dt} = -\frac{i}{\hbar}[H, \rho] . \quad (420)$$

Both are completely equivalent. (The new expression is sometimes also called the *von Neumann equation*.) We won’t actually do any calculations here. The expressions are given so that you recognize them when you encounter them elsewhere.

We now have a look at the opposite situation. In contrast to the case just mentioned, a density matrix for macroscopic distinct states with *vanishing* off-diagonal elements, such as the two state example

$$\begin{aligned}\rho &= |a|^2 \psi_a \otimes \psi_a^\dagger + |b|^2 \psi_b \otimes \psi_b^\dagger \\ &= (\psi_a, \psi_b) \begin{pmatrix} |a|^2 & 0 \\ 0 & |b|^2 \end{pmatrix} \begin{pmatrix} \psi_a^\dagger \\ \psi_b^\dagger \end{pmatrix}\end{aligned}\quad (421)$$

describes a system which possesses *no* phase coherence at all. Such a diagonal density matrix cannot be that of a pure state; it describes a system which is in the state ψ_a with probability $|a|^2$ and which is in the state ψ_b with probability $|b|^2$. Such a system is said to be in a *mixed state*, because its state is *not known*, or equivalently, to be in a (*phase*) *incoherent superposition*, because interference effects cannot be observed in such a situation. A system described by a mixed state is always *either* in the state ψ_a *or* in the state ψ_b . In other words, a diagonal density matrix for macroscopically distinct states is not in contrast, but in agreement with everyday experience. In the picture of density matrices, the non-diagonal elements contain the difference between normal, i.e. incoherent, and unusual, i.e. coherent, superpositions.

The experimental situation is clear: for macroscopically distinct states, only diagonal density matrices are observed. Any system in a coherent macroscopic superposition somehow loses its off-diagonal matrix elements. How does this process of *decoherence* take place? The density matrix itself shows the way.

Indeed, the density matrix for a large system is used, in thermodynamics, for the definition of its entropy and of all its other thermodynamic quantities. These studies show that

Ref. 3

Challenge 185

$$S = -k \operatorname{tr}(\rho \ln \rho) \quad (422)$$

where tr denotes the *trace*, i.e. the sum of all diagonal elements. We also remind ourselves that a system with a large and constant entropy is called a *bath*. In simple physical terms, a bath is thus a system to which we can ascribe a temperature. More precisely, a (*physical*) *bath*, or *reservoir*, is any large system for which the concept of *equilibrium* can be defined. Experiments show that in practice, this is equivalent to the condition that a bath consists of many interacting subsystems. For this reason, all macroscopic quantities describing the state of a bath show small, irregular *fluctuations*, a fact that will be of central importance shortly.

It is easy to see from the definition (422) of entropy that the loss of off-diagonal elements corresponds to an increase in entropy. And it is known that increases in entropy of a reversible system, such as the quantum mechanical system in question, are due to interactions with a bath.

Challenge 202

Where is the bath interacting with the system? It obviously must be outside the system one is talking about, i.e. in its *environment*. Indeed, we know experimentally that any environment is large and is characterized by a temperature; examples are listed in Table 44. Any environment therefore contains a bath. We can even go further: for every experimental situation, there is a bath *interacting* with the system. Indeed, every system which can be

observed is not isolated, as it obviously interacts at least with the observer; and every observer contains a bath, as we will show in more detail shortly. Usually however, the most important baths we have to take into consideration are the atmosphere around a system, the radiation attaining the system or, if the system itself is large enough to have a temperature, those degrees of freedom of the system which are not involved in the superposition under investigation.

At first sight, this direction of thought is not convincing. The interactions of a system with its environment can be made very small by using clever experimental set-ups. That would imply that the time for decoherence can be made arbitrary large. Let us check how much time a superposition of states needs to decohere. It turns out that there are two standard ways to estimate the *decoherence time*: either modelling the bath as large number of colliding particles, or by modelling it as a continuous field.

Table 44 Some common and less common baths with their main properties

Bath type	temperature T	wavelength λ_{eff}	particle flux ϕ	hit time $t_{\text{hit}} = 1/\sigma\phi$ for atom ^a	hit time $t_{\text{hit}} = 1/\sigma\phi$ for object ^a
matter baths					
solid, liquid	300 K	10 pm	$10^{31} / \text{m}^2\text{s}$	10^{-12} s	10^{-25} s
air	300 K	10 pm	$10^{28} / \text{m}^2\text{s}$	10^{-9} s	10^{-22} s
laboratory vacuum	50 mK	$10 \mu\text{m}$	$10^{18} / \text{m}^2\text{s}$	10 s	10^{-12} s
photon baths					
sunlight	5800 K	900 nm	$10^{23} / \text{m}^2\text{s}$	10^{-4} s	10^{-17} s
‘darkness’	300 K	$20 \mu\text{m}$	$10^{21} / \text{m}^2\text{s}$	10^{-2} s	10^{-15} s
cosmic microwaves	2.7 K	2 mm	$10^{17} / \text{m}^2\text{s}$	10^2 s	10^{-11} s
terrestrial radio waves	300 K				
Casimir effect	.. K				
Unruh radiation of earth	.. K				
nuclear radiation baths					
radioactivity		10 pm		$10^{\cdot\cdot} \text{ s}$	$10^{\cdot\cdot} \text{ s}$
cosmic radiation	>1000 K	10 pm		$10^{\cdot\cdot} \text{ s}$	$10^{\cdot\cdot} \text{ s}$
solar neutrinos	$\approx 10 \text{ MK}$	10 pm	$10^{15} / \text{m}^2\text{s}$	$10^{\cdot\cdot} \text{ s}$	$10^{\cdot\cdot} \text{ s}$
cosmic neutrinos	2.0 K	3 mm	$10^{17} / \text{m}^2\text{s}$	$10^{\cdot\cdot} \text{ s}$	$10^{\cdot\cdot} \text{ s}$
gravitational baths					
gravitational radiation	n.a.	...		$>10^{\cdot\cdot} \text{ s}$	$>10^{\cdot\cdot} \text{ s}$

a. The cross section σ in the case of matter and photon baths was assumed to be 10^{-19} m^2 for atoms; for the macroscopic object a size of 1 mm was used as example. For neutrino baths, ...

If the bath is described as a set of particles randomly hitting the microscopic system, it is characterized by a characteristic wavelength λ_{eff} of the particles, and by the average interval t_{hit} between two hits. A straightforward calculation shows that the decoherence time t_d is in

Challenge 219

any case smaller than this time interval, so that

$$t_d \leq t_{\text{hit}} = \frac{1}{\varphi\sigma} \quad , \quad (423)$$

where φ is the flux of particles and σ is the cross section for the hit. * Typical values are given in Table 44. We easily note that for macroscopic objects, decoherence times are extremely short. Scattering leads to fast decoherence. However, for atoms or smaller systems, the situation is different, as expected.

A second method to estimate the decoherence time is also common. Any interaction of a system with a bath is described by a relaxation time t_r . The term *relaxation* designates any process which leads to the return to the equilibrium state. The terms *damping* and *friction* are also used. In the present case, the relaxation time describes the return to equilibrium of the combination bath and system. Relaxation is an example of an irreversible evolution. A process is called *irreversible* if the reversed process, in which every component moves in opposite direction, is of very low probability. ** For example, it is usual that a glass of wine poured into a bowl of water colours the whole water; it is very rarely observed that the wine and the water separate again, since the probability of all water and wine molecules to change directions together at the same time is rather low, a state of affairs making the happiness of wine producers and the despair of wine consumers.

Now let us simplify the description of the bath. We approximate it by a single, unspecified, scalar field which interacts with the quantum system. Due to the continuity of space, such a field has an infinity of degrees of freedom. They are taken to model the many degrees of freedom of the bath. The field is assumed to be in an initial state where its degrees of freedom are excited in a way described by a temperature T . The interaction of the system with the bath, which is at the origin of the relaxation process, can be described by the repeated transfer of small amounts of energy E_{hit} until the relaxation process is completed.

The objects of interest in this discussion, like the mentioned cat, person or car, are described by a mass m . Their main characteristic is the maximum energy E_r which can be transferred from the system to the environment. This energy describes the interactions between system and environment. The superpositions of macroscopic states we are interested in are solutions of the Hamiltonian evolution of these systems.

Ref. 6 The initial coherence of the superposition, so disturbingly in contrast with our everyday experience, disappears exponentially within a *decoherence time* t_d given by ***

* The decoherence time is derived by studying the evolution of the density matrix $\rho(x, x')$ of objects localized at two points x and x' . One finds that the off-diagonal elements follow $\rho(x, x', t) = \rho(x, x', 0)e^{-\Lambda(x-x')^2}$, where the localization rate Λ is given by

$$\Lambda = k^2\varphi\sigma_{\text{eff}} \quad (424)$$

Ref. 4 where k is the wave number, φ the flux, and σ_{eff} the cross section of the collisions, i.e. usually the size of the macroscopic object.

Ref. 5 One also finds the surprising result that a system hit by a particle of energy E_{hit} collapses the density matrix roughly down to the de Broglie (or thermal de Broglie) wavelength of the hitting particle. Both results together give the formula above.

** Beware of other definitions which try to make something deeper out of the concept of irreversibility, such as claims that ‘irreversible’ means that the reversed process is *not at all* possible. Many so-called ‘contradictions’ between the irreversibility of processes and the reversibility of evolution equations are due to this mistaken interpretation of the term ‘irreversible’.

This is a section of the freely downloadable e-textbook

Motion Mountain

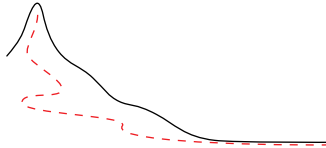

Hiking beyond space and time along the concepts of modern physics

available at
www.motionmountain.org

Copyright © 1997, 1998, 1999, 2000, 2001, 2002 by Christoph Schiller

To the kind reader

In exchange for getting this section for free, I ask you for a short email on some of the following:

- Which page was boring?
- Did you find any mistakes?
- What else were you expecting?
- What was hard to understand?

Of course, any other suggestion is welcome. This section is part of a physics text written over many years. The text lives and grows through the feedback from its readers, who help to improve and to complete it. For a particularly useful contribution (send it in english, italian, dutch, german, spanish, portuguese, or french) you will be mentioned in the foreword of the text, or receive a small reward, or both.

Enjoy!

Christoph Schiller
cs@motionmountain.org

Challenge 236

$$t_d = t_r \frac{E_{\text{hit}}}{E_r} \frac{e^{E_{\text{hit}}/kT} - 1}{e^{E_{\text{hit}}/kT} + 1} \quad (427)$$

where k is the *Boltzmann constant* and like above, E_r is the maximum energy which can be transferred from the system to the environment. Note that one always has $t_d \leq t_r$. After a time interval of length t_d is elapsed, the system has evolved from the coherent to the incoherent superposition of states, or, in other words, the density matrix has lost its off-diagonal terms. One also says that the phase coherence of this system has been destroyed. Thus, after a time t_d , the system is found either in the state ψ_a or in the state ψ_b , respectively with the probability $|a|^2$ or $|b|^2$, and not anymore in a coherent superposition which is so much in contradiction with our daily experience. Which final state is selected depends on the precise state of the bath, whose details were eliminated from the calculation by taking an *average* over the states of its microscopic constituents.

The important result is that for all macroscopic objects, the decoherence time t_d is very small. In order to see this more clearly, we can study a special simplified case. A macroscopic object of mass m , like the mentioned cat or car, is assumed to be at the same time in two locations separated by a distance l , i.e. in a superposition of the two corresponding states. We further assume that the superposition is due to the object moving as a quantum mechanical oscillator with frequency ω between the two locations; this is the simplest possible system that shows superpositions of an object located in two different positions. The energy of the object is then given by $E_r = m\omega^2 l^2$, and the smallest transfer energy $E_{\text{hit}} = \hbar\omega$ is the difference between the oscillator levels. In a macroscopic situation, this last energy is

Ref. 8 much smaller than kT , so that from the preceding expression we get

$$t_d = t_r \frac{E_{\text{hit}}^2}{2E_r kT} = t_r \frac{\hbar^2}{2mkTl^2} = t_r \frac{\lambda_T^2}{l^2} \quad (428)$$

in which the frequency ω has disappeared. The quantity $\lambda_T = \hbar/\sqrt{2mkT}$ is called the *thermal de Broglie wavelength* of a particle.

It is straightforward to see that for practically all macroscopic objects the typical decoherence time t_d is very short. For example, setting $m = 1$ g, $l = 1$ mm and $T = 300$ K we get $t_d/t_r = 1.3 \cdot 10^{-39}$. Even if the interaction between the system and the environment would be so weak that the system would have as relaxation time the age of the universe, which is about $4 \cdot 10^{17}$ s, the time t_d would still be shorter than $5 \cdot 10^{-22}$ s, which is over a million times faster than the oscillation time of a beam of light (about 2 fs for green light). For

Ref. 7 *** This result is derived as in the above case. A system interacting with a bath always has an evolution given by the general form

$$\frac{d\rho}{dt} = -\frac{i}{\hbar}[H, \rho] - \frac{1}{2t_o} \sum_j [V_j \rho, V_j^\dagger] + [V_j, \rho V_j^\dagger] \quad (425)$$

Challenge 253 Are you able to see why? Solving this equation, one finds for the elements far from the diagonal $\rho(t) = \rho_o e^{-t/t_o}$. In other words, they disappear with a characteristic time t_o . In most situations one has a relation of the form

$$t_o = t_r \frac{E_{\text{hit}}}{E_r} = t_{\text{hit}} \quad (426)$$

or some variations of it, as in the example above.

Schrödinger's cat, the decoherence time would be even shorter. These times are so short that we cannot even hope to *prepare* the initial coherent superposition, let alone to observe its decay or to measure its lifetime.

For microscopic systems however, the situation is different. For example, for an electron in a solid cooled to liquid helium temperature we have $m = 9.1 \cdot 10^{-31}$ kg, and typically $l = 1$ nm and $T = 4$ K; we then get $t_d \approx t_r$ and therefore the system can stay in a coherent superposition until it is relaxed, which confirms that for this case coherent effects can indeed be observed if the system is kept isolated. A typical example is the behaviour of electrons in superconducting materials. We will mention a few more below.

Ref. 9

In 1996 the first actual measurement of decoherence times was published by the Paris team around Serge Haroche.

Ref. 10

Conclusions on decoherence, life, and death

In summary, both estimates of decoherence times tell us that for most macroscopic objects, in contrast to microscopic ones, both the preparation and the survival of superpositions of macroscopically different states is made practically impossible by the interaction with any bath found in their environment, even if the usual measure of this interaction, given by the friction of the motion of the system, is very small. Even if a macroscopic system is subject to an extremely low friction, leading to a very long relaxation time, its decoherence time is still vanishingly short.

Our everyday environment is full of baths. Therefore, *coherent superpositions of macroscopically distinct states never appear in nature*. In short, we cannot be dead and alive at the same time.

We also take a second conclusion: *decoherence results from coupling to a bath in the environment*. Decoherence is a thermodynamic, statistical effect. We will return to this issue below.

What is a system? What is an object?

In classical physics, a system is a part of nature which can be isolated from its environment. However, quantum mechanics tells us that isolated systems do not exist, since interactions cannot be made vanishingly small. The results above allow us to define the concept of system with more accuracy. A *system* is any part of nature which interacts *incoherently* with its environment. In other words, an *object* is a part of nature interacting with its environment only through baths.

In particular, a system is called *microscopic* or *quantum mechanical* and can be described by a wavefunction ψ whenever

- it is almost isolated, with $t_{\text{evol}} = \hbar/\Delta E < t_r$, and
- it is in *incoherent* interaction with its environment.

Ref. 11

In short, a microscopic system interacts incoherently and weakly with its environment.

In contrast, a bath is never isolated in the sense just given, because its evolution time is always much larger than its relaxation time. Since all macroscopic bodies are in contact with baths – or even contain one – they cannot be described by a wavefunction. In particular, one cannot describe any measuring apparatus with help of a wavefunction.

We thus conclude that a *macroscopic system* is a system with a decoherence time much shorter than any other evolution time of its constituents. Obviously, macroscopic systems also interact incoherently with their environment. Thus cats, cars, and television news speakers are all macroscopic systems.

A third possibility is left over by the two definitions: what happens in the situation in which the interactions with the environment are *coherent*? We will encounter some examples shortly. Following this definition, such situations are *not* systems, and cannot be described by a wavefunction. For example, it can happen that a particle forms neither a macroscopic nor a microscopic system!

Nature is composed of many parts. Matter is composed of particles. Can parts be defined precisely? Can they be isolated from each other and pinned down unambiguously? In quantum theory, nature is not found to be made of isolated entities, but is still made of *separable* entities. The criterion of separability is the incoherence of interaction. Any system whose parts interact coherently is not separable. So the discovery of coherent superpositions includes the surprising consequence that there are systems which, even though they look separable, are not. In nature, some systems are *not* divisible. Quantum mechanics thus also stresses the *interdependence* of the parts of nature. By the way, in the third part of the walk we will encounter much stronger types of interdependence.

All surprising properties of quantum mechanics, such as Schrödinger's cat, are consequences of the classical prejudice that a system made of two or more parts must necessarily be divisible into two subsystems. Whenever one tries to divide indivisible systems, one gets strange or incorrect conclusions, such as apparent faster-than-light propagation, or, as one says today, non-local behaviour. Let us have a look at a few typical examples.

Is quantum theory non-local? – A bit about EPR

Mr. Duffy lived a short distance away from his body.
James Joyce

See page 312 We asked about non-locality also in general relativity. Let us study the situation in quantum mechanics. We first look at the wavefunction collapse for an electron hitting a screen after passing a slit. Following the description just deduced, the process looks roughly as depicted in Figure 210. A movie of the same process can be seen in the lower right corners on the pages of the present, second part of our mountain ascent. The situation is surprising: a wavefunction collapse gives the impression to involve faster than light propagation, because the maximum of the function changes position at extremely high speed, due to the short decoherence time. Does this happen faster than light? Yes, it does. But is it a problem?

Challenge 270 A situation is called *acausal* or *nonlocal* if energy is transported faster than light. Using Figure 210 you can determine the energy velocity involved, using the results on signal propagation. The result is a value smaller than c . A wavefunction maximum moving faster than light does *not* imply energy motion faster than light. *

See page 374

* In classical electrodynamics, the same happens with the scalar and the vector potential, if the Coulomb gauge is used.

Another often cited Gedankenexperiment was proposed by Bohm* in the discussion around the so-called Einstein-Podolsky-Rosen paradox. In the famous EPR paper the three authors try to find a contradiction between quantum mechanics and common sense. Bohm translated their rather confused paper into a clear thought experiment. When two particles in a spin 0 state move apart, measuring one particle's spin orientation implies an *immediate* collapse also of the other particle's spin, namely in the exactly opposite direction. This happens instantaneously over the whole separation distance; no speed limit is obeyed.

Ref. 12, 13

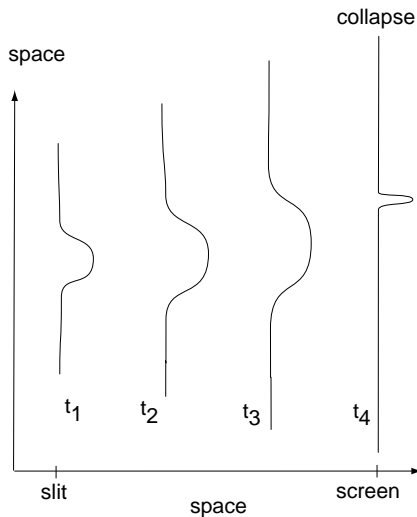

Figure 210 Quantum mechanical motion: an electron wave function (actually its module squared) from the moment it passes a slit until it hits a screen

We note again that no energy is transported faster than light. No non-locality is present, against numerous claims of the contrary in older literature. The two electrons belong to one system: assuming that they are separate only because the wavefunction has two distant maxima is a conceptual mistake. In fact, no signal can be transmitted with this method; it is a case of prediction which looks like a signal, as we already discussed in the section on special relativity.

See page 376

Such experiments have actually been performed. The first and most famous was the one performed in 1982, with photons instead of electrons by Alain Aspect. Like all latter ones, it has fully confirmed quantum mechanics.

Ref. 14

In fact, such experiments just confirm that it is not possible to treat either of the two particles as a system, and to ascribe them any property by themselves, such as spin. The Heisenberg picture would express this even more clearly.

These first two examples of apparent non-locality can be dismissed with the remark that since obviously no energy flux faster than light is involved, no problems with causality appear. Therefore the following example is more interesting. Take two identical atoms, one

* David Bohm (19.. –1997/8) British physicist, codiscovered the Aharonov-Bohm effect; he spent a large part of his life investigating the connections between quantum physics and philosophy.

in an excited state, one in the ground state, and call l the distance that separates them. Common sense tells that if the first atom returns to its ground state emitting a photon, the second atom can be excited only after a time $t = l/c$ has been elapsed, i.e. after the photon has travelled to the second atom.

Surprisingly, this conclusion is wrong. The atom in its ground state has a nonzero probability to be excited directly at the same moment in which the first is deexcited. This has been shown most simply by Hegerfeldt. The result has even been confirmed experimentally.

Ref. 15

More careful studies show that the result depends on the type of superposition of the two atoms at the beginning: coherent or incoherent. For incoherent superpositions, the intuitive result is correct; the surprising result appears only for coherent superpositions. This pretty conclusion again avoids non-locality.

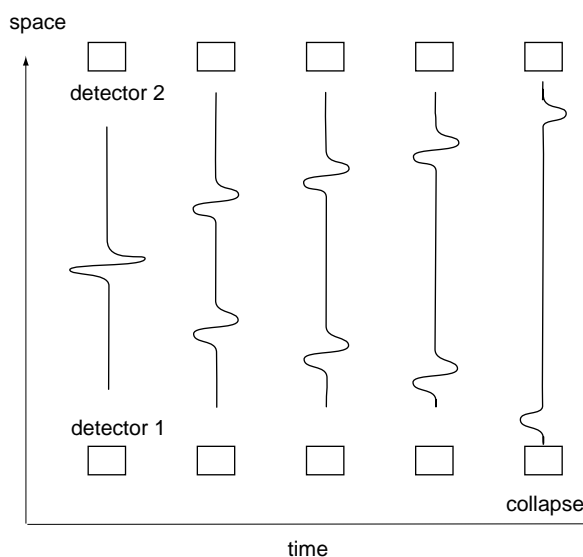

Figure 211 Bohm's Gedankenexperiment

Curiosities

▪ In a few rare cases, the superposition of different macroscopic states can actually be observed by lowering the temperature to sufficiently small values and by carefully choosing suitably small masses or distances. Two well-known examples of coherent superpositions are those observed in gravitational wave detectors and in Josephson junctions. In the first case, one observes a mass as heavy as 1000 kg in a superposition of states located at different points in space: the distance between them is of the order of 10^{-17} m. In the second case, in superconducting rings, superpositions of a state in which a macroscopic current of the order of 1 pA flows in clockwise direction with one where it flows in counterclockwise direction have been produced.

Ref. 8

Ref. 22

▪ Obviously, superpositions of magnetization in up and down direction for several materials have also been observed.

Ref. 16

▪ Since the 1990s, the sport of finding and playing with new systems in coherent superpositions has taken off world-wide. Its challenges lie in the clean experiments necessary. Experiments with single atoms in superpositions of states are among the most popular ones.

Ref. 18

Ref. 19

Ref. 20

▪ In 1997, coherent atom waves were extracted from a cloud of sodium atoms.

▪ Macroscopic objects thus usually are in incoherent states. This is the same situation as for light. The world is full of 'macroscopic', i.e. incoherent light: daylight, and all light from lamps, from fire, and from glow-worms is incoherent. Only very special and carefully constructed sources, such as lasers or small point sources, emit coherent light. Only these allow to study interference effects. In fact, the terms 'coherent' and 'incoherent' originated

in optics, since for light the difference between the two, namely the capacity to interfere, had been observed centuries before the case of matter.

Coherence and incoherence of light and of matter manifest themselves differently, since matter can stay at rest but light cannot, and because light is made of bosons, but matter is made of fermions. Coherence can be observed easily in systems composed of bosons, such as light, sound in solids, or electron pairs in superconductors. Coherence is less easily observed in systems of fermions, such as systems of atoms. However, in both cases a decoherence time can be defined. In both cases coherence in many particle systems is best observed if all particles are in the same state (superconductivity, laser light), and in both cases the transition from coherent to incoherent is due to the interaction with a bath. A beam is thus incoherent if its particles arrive randomly in time and in frequency. In everyday life, the rarity of observation of coherent matter superpositions has the same origin as the rarity of observation of coherent light.

See page 533

- We will discuss the relation between the environment and the *decay* of unstable systems later on. The phenomenon is completely described by the concepts given here.

See page 568

- Another conclusion deserves to be mentioned: *teleportation contradicts correlations*. Can you confirm it?

Challenge 287

What is all the fuzz about measurements in quantum theory?

Measurements in quantum mechanics are disturbing. They lead to statements in which *probabilities* appear. That is puzzling. For example, we speak about the probability of finding an electron at a certain distance from the nucleus of an atom. Statements like this belong to the general type ‘when the observable A is measured, the probability to find the outcome a is p .’ In the following we will show that the probabilities in such statements are inevitable for any measurement, because, as we will show, any measurement and any observation is a special case of decoherence process. (Historically however, the process of measurement was studied before the more general process of decoherence. That explains in part why the topic is so confused in many peoples’ minds.)

What is a measurement? As already mentioned in the intermezzo a measurement is any interaction which produces a record or a memory. Measurements can be performed by machines; when they are performed by people, they are called observations. In quantum theory, the action of measurement is not as straightforward as in classical physics. This is seen most strikingly when a quantum system, such as a single electron, is first made to pass a diffraction slit, or better – in order to make its wave aspect become apparent – a double slit, and then is made to hit a photographic plate, in order to make its particle aspect appear. One observes the well known fact that the blackened dot, the spot where the electron has hit the screen, cannot be determined in advance. (The same is true for photons or any other particle.) However, for large numbers of electrons, the spatial distribution of the black dots, the so-called *diffraction pattern*, can be calculated in advance with high precision.

See page 422

The outcome of experiments on microscopic systems thus forces us to use probabilities for the description of microsystems. We find that the probability distribution $p(\mathbf{x})$ of the spots on the photographic plate can be calculated from the wavefunction ψ of the electron at the screen surface and is given by $p(\mathbf{x}) = |\psi^\dagger(\mathbf{x})\psi(\mathbf{x})|^2$. This is in fact a special case of the general *first property of quantum measurements*: the measurement of an observable A

for a system in a state ψ gives as result one of the eigenvalues a_n , and the probability P_n to get the result a_n is given by

$$P_n = |\varphi_n^\dagger \psi|^2 \quad , \quad (429)$$

See page 853 where φ_n is the eigenfunction of the operator A corresponding to the eigenvalue a_n .

Experiments also show a *second property of quantum measurements*: after the measurement, the observed quantum system is in the state φ_n corresponding to the measured eigenvalue a_n . One also says that during the measurement, the wavefunction has *collapsed* from ψ to φ_n . By the way, both properties can also be generalized to the more general cases with degenerate and continuous eigenvalues.

Ref. 21

At first sight, the sort of probabilities encountered in quantum theory are different from the probabilities we encounter in everyday life. Roulette, dice, pachinko machines, the direction in which a pencil on its tip falls, have been measured experimentally to be random (assuming no cheating) to a high degree of accuracy. These systems do not puzzle us. We unconsciously assume that the random outcome is due to the small, but uncontrollable variations of the starting conditions every time the experiment is repeated.*

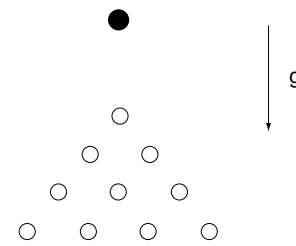

Figure 212 A system showing probabilistic behaviour

But microscopic systems seem to be different. The two measurement properties just mentioned express what physicists observe in every experiment, even if the initial conditions are taken to be *exactly* the same every time. But why then is the position for a single electron, or most other observables of quantum systems, not predictable? In other words, what happens during the collapse of the wavefunction? How long does it take? In the beginning of quantum theory, there was the perception that the observed unpredictability is due to the lack of information about the state of the particle. This led many to search for so-called ‘hidden variables’; all these attempts were doomed to fail, however. It took some time for the scientific community to realize that the unpredictability is *not* due to the lack of information about the state of the particle, which is indeed described *completely* by the state vector ψ .

See page 421

In order to uncover the origin of probabilities, let us recall the nature of a measurement, or better, of a general observation. *Any observation is the production of a record.* The record can be a visual or auditive memory in our brain, or a written record on paper, or a tape recording, or any such type of object. As explained in the intermezzo, an object is a record if it cannot have arisen or disappeared by chance. To avoid the influence of chance, all records have to be protected as much as possible from the outer world; e.g. one typically puts archives in earthquake safe buildings with fire protection, keeps documents in a safe, avoids brain injury as much as possible, etc.

On top of this, records have to be protected from their internal fluctuations. These internal fluctuations are due to the fact that a record, being an object, consists of many components. If the fluctuations were too large, they would make it impossible to distinguish between the

* To get a feeling for the limitations of these unconscious assumptions, you may want to read the story of those physicists who build a machine who could predict the outcome of a roulette ball from the initial velocity imparted by the croupier. The story is told by

possible contents of a memory. Now, fluctuations decrease with increasing size of a system, typically with the square root of the size. For example, if a hand writing is too small, it is difficult to read if the paper gets brittle; if the magnetic tracks on tapes are too small, they demagnetize and loose the stored information. In other words, a record is rendered stable against internal fluctuations by making it of sufficient size. Every record thus consists of many components and shows small fluctuations.

Therefore, every system with memory, i.e. every system capable of producing a record, contains a *bath*. In summary, the statement that any observation is the production of a record can be expressed more precisely as: *Any observation of a system is the result of an interaction between that system and a bath in the recording apparatus.* *

But we can say more. Obviously, any observation measuring a physical quantity uses an interaction *depending* on that same quantity. With these seemingly trivial remarks, one can describe in more detail the process of observation, or as it is usually called in the quantum theory, the measurement process.

Any measurement apparatus, or *detector*, is characterized by two main aspects: the interaction it has with the microscopic system, and the bath it contains to produce the record. Any description of the measurement process thus is the description of the evolution of the microscopic system *and* the detector; therefore one needs the Hamiltonian for the particle, the interaction Hamiltonian, and the bath properties, such as the relaxation time. The interaction specifies what is measured, and the bath realizes the memory.

Ref. 17

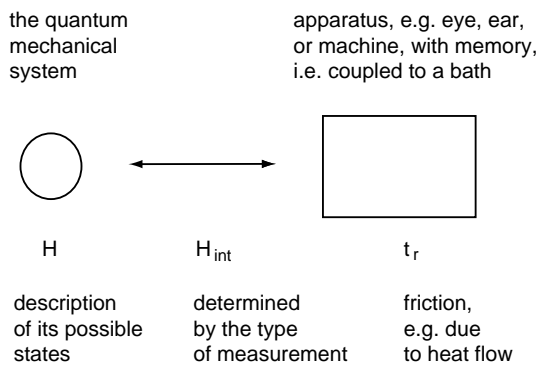

Figure 213 The concepts used in the description of measurements

– by a state ψ . This state can always be written as $\psi = \psi_p \psi_{other} = \sum_n c_n \phi_n \psi_{other}$, where ψ_{other} represents the other degrees of freedom of the particle, i.e. those not described – *spanned*, in mathematical language – by the operator A corresponding to the observable we want to measure. The numbers $c_n = |\langle \phi_n | \psi_p \rangle|$ give the expansion of the state ψ_p , which is taken to be normalized, in terms of the basis ϕ_n . For example, in a typical position measurement, the functions ϕ_n would be the position eigenfunctions and ψ_{other} would contain the information about the momentum, the spin, and all other properties of the particle.

How does the system-detector interaction look like? Let us call the state of the apparatus before the measurement χ_{start} ; the measurement apparatus itself, by definition, is a device

* Since baths imply friction, we can also say: memory needs friction.

We know that only classical thermodynamic systems can be irreversible; quantum systems are not. We therefore conclude: a measurement system *must* be described classically: otherwise it has no memory and is not measurement system: it produces no record! Nevertheless, let us see what happens if one describes the measurement system quantum mechanically. Let us call A the observable which is measured in the experiment and its eigenfunctions ϕ_n . We describe the quantum mechanical system under observation – often a

which, when it is hit by a particle in the state $\phi_n \psi_{\text{other}}$, changes from the state χ_{start} to the state χ_n . One then says that the apparatus has *measured* the eigenvalue a_n corresponding to the eigenfunction ϕ_n of the operator A . The index n is thus the record of the measurement; it is called the *pointer* index or variable. This index tells us in which state the microscopic system was before the interaction. The important point, taken from our previous discussion, is that the states χ_n , being records, are macroscopically distinct, precisely in the sense of the previous section. Otherwise they would not be records, and the interaction with the detector would not be a measurement.

Of course, during measurement, the apparatus sensitive to ϕ_n changes the part ψ_{other} of the particle state to some other situation $\psi_{\text{other},n}$, which depends on the measurement and on the apparatus; we do not need to specify it in the following discussion. * Let us have an intermediate check of or reasoning. Do apparatuses as described here exist? Yes, they do. For example, any photographic plate is a detector for the position of ionizing particles. A plate, and in general any apparatus measuring position, does this by changing its momentum in a way depending on the measured position: the electron on a photographic plate is stopped. In this case, χ_{start} is a white plate, ϕ_n would be a particle localized at spot n , χ_n is the function describing a plate blackened at spot n and $\psi_{\text{other},n}$ describes the momentum and spin of the particle after it has hit the photographic plate at the spot n .

Now we are ready to look at the measurement process itself. For the moment, let us disregard the bath in the detector. In the time before the interaction between the particle and the detector, the combined system was in the initial state ψ_i given simply by

$$\psi_i = \psi_p \chi_{\text{start}} = \sum_n c_n \phi_n \psi_{\text{other}} \chi_{\text{start}} \quad . \quad (432)$$

After the interaction, using the just mentioned characteristics of the apparatus, the combined state ψ_a is

$$\psi_a = \sum_n c_n \phi_n \psi_{\text{other},n} \chi_n \quad . \quad (433)$$

This evolution from ψ_i to ψ_a follows from the evolution equation applied to the particle detector combination. Now the state ψ_a is a superposition of macroscopically distinct states, as it is a superposition of distinct macroscopic states of the detector. In our example ψ_a could correspond to a superposition of a state where a spot on the left upper corner is blackened on an otherwise white plate with one where a spot on the right lower corner of the otherwise white plate is blackened. Such a situation is never observed. This is due to the fact that the

* How does the interaction look like mathematically? From the description we just gave, we specified the final state for every initial state. Since the two density matrices are related by

$$\rho_f = T \rho_i T^\dagger \quad (430)$$

Challenge 304 we can deduce the Hamiltonian from the matrix T . Are you able to see how?

By the way, one can say in general that an apparatus measuring an observable A has a system interaction Hamiltonian depending on the pointer variable A , and for which one has

$$[H + H_{\text{int}}, A] = 0 \quad . \quad (431)$$

density matrix ρ_a of this situation, given by

$$\rho_a = \Psi_a \otimes \Psi_a^\dagger = \sum_{n,m} c_n c_m^* (\varphi_n \Psi_{\text{other},n} \chi_n) \otimes (\varphi_m \Psi_{\text{other},m} \chi_m)^\dagger, \quad (434)$$

contains non-diagonal terms, i.e. terms for $n \neq m$, whose numerical coefficients are different from zero.

Now let's take the bath back in. From the previous section we know the effect of a bath on such a macroscopic superposition. We found that a density matrix such as ρ_a decoheres extremely rapidly. We assume here that the decoherence time is negligibly small, in practice thus instantaneous,* so that the off-diagonal terms vanish, and only the the final, diagonal density matrix ρ_f , given by

$$\rho_f = \sum_n |c_n|^2 (\varphi_n \Psi_{\text{other},n} \chi_n) \otimes (\varphi_n \Psi_{\text{other},n} \chi_n)^\dagger \quad (435)$$

has experimental relevance. As explained above, such a density matrix describes a mixed state, and the numbers $P_n = |c_n|^2 = |\varphi_n^\dagger \Psi_p|^2$ give the probability of measuring the value a_n and of finding the particle in the state $\varphi_n \Psi_{\text{other},n}$ as well as the detector in the state χ_n . But this is precisely what the two properties of quantum measurements state.

We therefore find that describing a measurement as an evolution of a quantum system interacting with a macroscopic detector, itself containing a bath, we can *deduce* the two properties of quantum measurements, and thus the collapse of the wave function, from the quantum mechanical evolution equation. The decoherence time of the previous section becomes the time of collapse in the case of a measurement:

$$t_{\text{collapse}} = t_d < t_r \quad (436)$$

We thus have a formula for the time the wavefunction takes to collapse. The first experimental measurements of the time of collapse are appearing, and confirm these results. Ref. 23

Hidden variables

Obviously a large number of people is not satisfied with the arguments just presented. They long for more mystery in quantum theory. The most famous approach is the idea that the probabilities are due to some hidden aspect of nature which is still unknown to humans. But the beautiful thing about quantum mechanics is that it allows both conceptual and experimental tests on whether such *hidden variables* exist without the need of knowing them.

- The first argument against hidden variables was given by John von Neumann. **

– CS – to be written – CS –

- An additional no-go theorem for hidden variables was published by Kochen and Specker Ref. 24

* Note however, that an *exactly* vanishing decoherence time, which would mean a *strictly* infinite number of degrees of freedom of the environment, is in contradiction with the evolution equation, and in particular with unitarity, locality and causality. It is essential in the whole argument not to confuse the logical consequences of a very small decoherence time with those of an exactly vanishing decoherence time.

** John von Neumann (1903, Budapest–1957, Washington DC) mathematician, one of the fathers of the modern computer.

in 1967, (and independently by Bell in 1969). It states that noncontextual hidden variables are impossible, if the Hilbert space has a dimension equal or larger than three. The theorem is about noncontextual variables, i.e. about hidden variables *inside* the quantum mechanical system. The Kochen-Specker theorem thus states that there is no noncontextual hidden variables model, because mathematics forbids it. This result essentially eliminates all possibilities, because usual quantum mechanical systems have dimensions much larger than three.

But also common sense eliminates hidden variables, without any recourse to mathematics, with an argument often overlooked. If a quantum mechanical system had internal hidden variables, the measurement apparatus would have zillions of them.* And that would mean that it could not work as a measurement system.

Of course, one cannot avoid noting that about *contextual* hidden variables, i.e. variables in the environment, there are no restricting theorems; indeed, their necessity was shown earlier in this section.

▪ Obviously, despite these results, people have also looked for experimental tests on hidden variables. Most tests are based on the famed *Bell's equation*, a beautifully simple relation published by John Bell** in the 1960s.

The starting idea is to distinguish quantum theory and locally realistic theories using hidden variables by measuring the polarizations of two correlated photons. Quantum theory says that the polarization of the photons is fixed only at the time it is measured, whereas local realistic theories say that it is fixed already in advance.

Imagine the polarization is measured at two distant points *A* and *B*, each observer can measure 1 or -1 in each of his favourite direction. Let each observer choose two directions, 1 and 2, and call their results a_1 , a_2 , b_1 , and b_2 . Since they all are either 1 or -1 , the value of the specific expression $(a_1 + a_2)b_1 + (a_2 - a_1)b_2$ has always the value ± 2 .

Ref. 25 Challenge 321 Imagine you repeat the experiment many times, assuming that the hidden variables appear statistically. You then can deduce (a special case of) Bell's equation

$$|(a_1b_1) + (a_2b_1) + (a_2b_2) - (a_1b_2)| \leq 2 \quad (437)$$

where the expressions in brackets are the averages of the measurement products over a large number of samples. This result holds independently of the directions of the involved polarizers.

On the other hand, if the polarizers 1 and 2 at position *A* and the corresponding ones at position *B* are chosen with angles of $\pi/4$, quantum theory predicts that the result is

$$|(a_1b_1) + (a_2b_1) + (a_2b_2) - (a_1b_2)| = 2\sqrt{2} > 2 \quad (438)$$

which is in complete contradiction with the hidden variable result.

So far, all experimental checks of Bell's equation have confirmed standard quantum mechanics. No evidence for hidden variables has been found. This is not really surprising, since the search for such variables is based on a misunderstanding of quantum mechanics or on personal desires on how the world should be, instead of relying on experimental evidence.

* Which leads to the definition: one zillion is 10^{23} .

** John Stewart Bell (1928–1990), theoretical physicist who worked mainly on the foundations of quantum theory.

Another measurable contradiction between quantum theory and locally realistic theories has been predicted by Greenberger, Horn and Zeilinger. Experiments trying to check the result are being planned. No deviation from quantum theory is expected.

Conclusions on probabilities and determinism

Geometric demonstramus quia facimus;
si physics demonstrare possemus, faceremus.
Giambattista Vico*

From the argument presented here, we draw a number of conclusions which we need for the rest of our mountain ascent. Note that these conclusions are not shared by all physicists! The whole topic is still touchy.

- Probabilities appear in measurements because the details of the state of the bath are unknown, not because the state of the quantum system is unknown. *Quantum mechanical probabilities are of statistical origin and are due to baths.* The probabilities are due to the large number of degrees of freedom contained in baths. These degrees of freedom make the outcome of experiments unpredictable. If the state of the bath were known, the outcome of an experiment could be predicted. The probabilities of quantum theory are ‘thermodynamic’ in origin.

In other words, there are *no* fundamental probabilities in nature. All probabilities in nature are due to statistics of many particles. Modifying well-known words by Albert Einstein, ‘nature really does not play dice.’ We therefore called ψ the *wave function* instead of ‘probability amplitude’, as is often done. ‘State function’ would be an even better name.

- Any observation in everyday life is a special case of decoherence. What is usually called the collapse of the wavefunction is a process due to the interaction with the bath present in any measuring apparatus. Because humans are warm-blooded and have memory, humans themselves are thus measurement apparatuses. The fact that our body temperature is 37 °C is thus the reason that we see only a single world, and no superpositions. **

- A measurement is complete when the microscopic system has interacted with the bath in the measuring apparatus. Quantum theory as a description of nature does not require detectors; the evolution equation describes all examples of motion. However, *measurements* do require the existence of detectors; and detectors have to include a bath, i.e. have to be classical, macroscopic objects. In this context one speaks also of a *classical apparatus*. This necessity of the measurement apparatus to be classical had been already stressed in the very early stages of quantum theory.

- All measurements, being decoherence processes, are irreversible processes and increase entropy.

- A measurement is a special case of quantum mechanical evolution, namely the evolution for the combination of a quantum system, a macroscopic detector and the environment.

* ‘We are able to demonstrate geometrical matters because we make them; if we could prove physical matters we would be able to make them.’ Giovanni Battista Vico (1668, Napoli– 1744, Napoli) important Italian philosopher and thinker. In this famous statement he points out a fundamental distinction between mathematics and physics.

Challenge 338 ** Actually, there are more reasons; can you name a few?

Since the evolution equation is relativistically invariant, no causality problems appear in measurements, no locality problems and no logical problems.

- Since the evolution equation does not involve quantities other than space-time, Hamiltonians and wave-functions, no other quantity plays a role in measurement. In particular, no observer nor any consciousness are involved or necessary. Every measurement is complete when the microscopic system has interacted with the bath in the apparatus. The decoherence inherent in every measurement takes place even if ‘nobody is looking.’ This trivial consequence is in agreement with the observations of everyday life, for example with the fact that the moon is orbiting the earth even if nobody looks at it. * Similarly, a tree falling in the middle of a forest makes noise even if nobody listens. Decoherence is independent of human observation, of the human mind, and of human existence.

- In every measurement the quantum system interacts with the detector. Since there is a minimum value for the magnitude of action, we cannot avoid the fact that *observation influences objects*. Therefore every measurement *disturbs* the quantum system. Any precise description of observations must also include the the description of this disturbance. In this section the disturbance was modelled by the change of the state of the system from Ψ_{other} to $\Psi_{\text{other},n}$. Without such a change of state, without a disturbance of the quantum system, a measurement is impossible.

- Since the complete measurement is described by quantum mechanics, unitarity is and remains the basic property of evolution. There are no non-unitary processes in quantum mechanics.

- The argument in this section for the description of the collapse of the wavefunction is an explanation exactly in the sense in which the term ‘explanation’ was defined in the intermezzo; it describes the relation between an observation and all the other aspects of reality, in this case the bath in the detector. The collapse of the wavefunction has been *explained*, it is not a question of ‘interpretation’, i.e. of opinion, as unfortunately often is suggested. **

See page 466

- It is not useful to speculate whether the evolution for a *single* quantum measurement could be determined, if the state of the environment around the system were known. Measurements need baths. But baths cannot be described by wavefunctions. *** Quantum mechanics is deterministic. Baths are probabilistic.

- In summary, there is *no* irrationality in quantum theory. Whoever uses quantum theory as argument for irrational behaviour, for ideologies, or for superstitions is guilty of disinformation. A famous example is the following quote.

Nobody understands quantum mechanics.
Richard Feynman

Challenge 355

* The opposite view is sometimes falsely attributed to Niels Bohr; the moon is obviously in contact with many radiation baths. Can you list a few?

Ref. 26

** This implies that the so-called ‘many worlds’ interpretation is wishful thinking. One also reaches this conclusion also when studying the details of this religious approach.

*** This very strong type of determinism will be very much softened in the last part of this text, in which it will be shown that time is not a fundamental concept, and therefore that the debate around determinism loses most of its interest.

What is the difference between space and time?

More specifically, why are objects localized in space but not in time? Most bath-system interactions are mediated by a potential. All potentials are by definition position dependent. Therefore, every potential, being a function of the position \mathbf{x} , commutes with the position observable (and thus with the interaction Hamiltonian). The decoherence induced by baths – except if special care is taken – thus first of all destroys the non-diagonal elements for every superposition of states centred at different locations. In short, *objects are localized because they interact with baths via potentials*.

For the same reason, objects also have only one spatial orientation at a time. If the system-bath interaction is spin-dependent, the bath leads to ‘localization’ in the spin variable. This happens for all microscopic systems interacting with magnets. For this reason, one practically never observes macroscopic superpositions of magnetization. Since electrons, protons and neutrons have a magnetic moment and a spin, this conclusion can even be extended: everyday objects are never seen in superpositions of different rotation states, because of spin-dependent interactions with baths.

As a counterexample, most systems are not localized in time, but on the contrary exist for very long times, because practically all system-bath interaction do *not* commute with time. This is in fact the way a bath is defined to begin with. In short, *objects are permanent because they interact with baths*.

Are you able to find an interaction which is momentum dependent? What is the consequence for macroscopic systems?

Challenge 372

In other words, in contrast to general relativity, quantum theory produces a distinction between space and time. In fact, we can *define* position as what commutes with interaction Hamiltonians. This distinction between space and time is due to the properties of matter and its interactions; we could not have found this result in general relativity.

Are we good observers?

Are humans classical apparatuses? Yes, they are. Even though several prominent physicists claim that free will and probabilities are related, a detailed investigation shows that this is not the case. Our senses are classical machines, in the sense described above. Our brain is also a classical apparatus, but the fact is secondary; our sensors are the key.

Ref. 27

In addition, we have stressed several times that any observing entity needs memory, which means it needs to incorporate a bath. That means that observers have to be made of matter; an observer cannot be made of radiation. Our description of nature is thus severely biased: we describe it from the standpoint of matter. That is a little like describing the stars by putting the earth at the centre of the universe. Can we eliminate this basic anthropomorphism? We will discover this question in the third part of our mountain ascent.

Does the ‘wavefunction of the universe’ exist?

This expression is frequently heard in discussions about quantum mechanics. Numerous conclusions are drawn from it, e.g. about the irreversibility of time, the importance of initial conditions, the decoherence of the universe, about changes required to quantum theory,

changes necessary to thermodynamics or the importance of the mind. Are these arguments correct?

See page 285 The first thing to clarify is the meaning of ‘universe’. As already explained the term can have two meanings: either the collection of all matter and radiation, or this collection *plus* all of space-time. Secondly, we have to recall the meaning of ‘wavefunction’: it describes the *state* of a system. The state distinguishes two otherwise identical systems; for example, position and velocity distinguish two otherwise identical ivory balls on a billiard table. Alternatively and equivalently, the state describes changes in time.

See page 34 Does the universe have a state? If we take the wider meaning of universe, obviously it does not. Talking about the state of the universe is a contradiction: by definition, the concept of state, defined as the non-permanent aspects of an object, is applicable only to *parts* of the universe.

We can take the narrower sense of ‘universe’, as sum of all matter and radiation only, without space and time, and ask the question again. To determine its state, we need a possibility to measure it: we need an environment. But the environment of the smaller universe is space-time only; initial conditions cannot be determined since we need measurements to do this, and thus an apparatus, i.e. a material system with a bath attached to it.

In short, standard quantum theory does not allow for measurements of the universe; therefore it has no state. Summing up, beware of anybody who claims to know something about the wavefunction of the universe. Just ask him: If you know the wavefunction of the universe, why aren’t you rich?

Several famous physicists have proposed evolution equations for the wavefunction of the universe! It seems a silly point, but the predictions of these equations cannot be compared to experiments; the arguments just given even make this impossible in principle. The pursuits in this directions, so interesting they are, must therefore be avoided if we want to reach the top of motion mountain.

There are many more twists to this story. One possibility is that space-time itself, even without matter, is a bath. This speculation will be shown to be correct later on and seems to allow speaking of the wavefunction of all matter. But then again, it turns out that time is *undefined* at the scales where space-time would be an effective bath; this means that the concept of state is not applicable there.

We can retain as result, valid even in the light of the latest results of physics: there is *no* wavefunction of the universe, independently of what is meant by ‘universe’. Before we go on studying the more complicated consequences of quantum theory for the whole universe, we first continue a bit with the consequences of quantum theory for our everyday observations.

Some curiosities and challenges of quantum electrodynamics

Typeset in
July 2002

Motion is an interesting topic, and when a curious person asks a question about it, most of the time quantum electrodynamics is needed for the answer. Together with gravity, quantum electrodynamics explains almost all of our everyday experience, including numerous surprises. Let us have a look at some of them.

- There is a famous riddle asking how far the last card (or the last brick) of a stack can hang over the edge of a table. Of course, only gravity, no glue or any other means is allowed to keep the cards on the table. After you solved the riddle, can you give the solution in case the uncertainty principle is taken into account?

Challenge 746

Challenge 763

- Quantum electrodynamics explains why there are only a *finite* number of different atom types. In fact, it takes only two lines to prove that pair production of electron-antielectron pairs make it impossible that a nucleus has more than about 137 protons. Can you show this? The effect at the basis of this limit, the polarisation of the vacuum, also plays a role in much larger systems, such a charged black holes, as we will see shortly.

Ref. 33

Challenge 780

See page 595

- Taking 91 of the 92 electrons off an uranium atom allows researchers to check whether the innermost electron still is described by QED. The electric field near the uranium nucleus, 1 EV/m is near the threshold for spontaneous pair production. The field is the highest constant field producible in the laboratory, and an ideal testing ground for precision QED experiments. The effect of virtual photons is to produce a Lamb shift; even in these extremely high fields, the value fits with the predictions.

Ref. 58

Challenge 797

See page 389

- Is there a critical magnetic field in nature, like there is a critical electric field?
- In classical physics, the field energy of a point-like charged particle, and hence its mass, was predicted to be infinite. QED effectively *smears out* the charge of the electron over its Compton wavelength, so that in the end the field energy contributes only a small correction to its total mass. Can you confirm this?

Challenge 814

- Microscopic evolution can be pretty slow. Light is always emitted from some metastable state. Usually, the decay times, being induced by the vacuum fluctuations, are much shorter than a microsecond. However, there are metastable atomic states with a lifetime of ten years: for example, an ytterbium ion in the $^2F_{7/2}$ state achieves this value, because the emission of light requires an octupole transition, in which the angular momentum changes by $3\hbar$; this is an extremely unlikely process.

Ref. 59

Challenge 831

- Microscopic evolution can be pretty fast. Can you imagine how to deduce or to measure the speed of electrons inside atoms? And inside metals?

- Take a horseshoe. The distance between the two ends is not fixed, since otherwise their position and velocity would be known at the same time, contradicting the uncertainty relation. Of course, this reasoning is also valid for any other solid object. In short, both quantum mechanics and special relativity show that rigid bodies do not exist, albeit for different reasons.

- Have you ever admired a quartz crystal or some other crystalline material? The beautiful shape and atomic arrangement has formed spontaneously, as a result of the motion of atoms

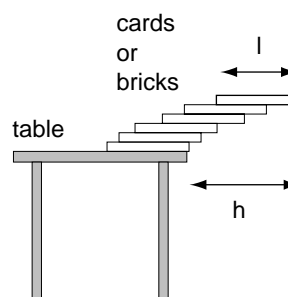

Figure 216 What is the maximum possible value of h/l ?

under high temperature and pressure, during the time that the material was deep under the earth's surface. The details of crystal formation are complex and interesting.

For example, are regular crystal lattices *energetically* optimal? This simple question leads to a wealth of problems. We might start with the much simpler question whether a regular dense packaging of spheres is the most *dense* possible. Its density is $\pi/\sqrt{18}$, i.e. a bit over 74%. Even though this was conjectured to be the maximum possible value already in 1609 by Johannes Kepler, the statement was proven only in 1998 by Tom Hales. The proof is difficult because in small volumes it is possible to pack spheres up to almost 78%. To show that over large volumes the lower value is correct is a tricky business.

Challenge 848

Ref. 61

Next, does a regular crystal of solid spheres, in which the spheres do *not* touch, have the lowest possible entropy? This simple problem has been the subject of research only in the 1990s. Interestingly, *for low temperatures*, regular sphere arrangements indeed show the largest possible entropy. At low temperatures, spheres in a crystal can oscillate around their average position and be thus more disordered than if they were in a liquid; in the liquid state the spheres would block each other's motion and would not allow to show disorder at all.

This result, and many similar ones deduced from the research into these so-called *entropic forces* show that the transition from solid to liquid is – at least in part – simply a geometrical effect. For the same reason, one gets the surprising result that even slightly repulsing spheres (or atoms) can form crystals, and melt at higher temperatures. These are beautiful examples of how classical thinking can explain certain material properties, using from quantum theory only the particle model of matter.

Ref. 62

But the energetic side of crystal formation provides other interesting questions. Quantum theory shows that it is possible that *two* atoms repel each other, while *three* attract each other. This beautiful effect was discovered and explained by Hans-Werner Fink in 1984. He studied rhenium atoms on tungsten surfaces and showed, as observed, that they cannot form dimers, but readily form trimers. This is an example contradicting classical physics; the effect is impossible if one pictures atoms as immutable spheres, but becomes possible when one remembers that the electron clouds around the atoms rearrange depending on their environment.

Ref. 63

For an exact study of crystal energy, the interactions between all atoms have to be included. The simplest question is to determine whether a regular array of alternatively charged spheres has lower energy than some irregular collection. Already such simple questions are still topic of research; the answer is still open.

Another question is the mechanism of face formation in crystals. Can you confirm that crystal faces are those planes with the *slowest* growth speed, because all fast growing planes are eliminated? (Just use a paper drawing at different times.) The finer details of the process form a complete research field in itself.

Challenge 865

Ref. 64

Finally, there remains the question of symmetry: why are crystals often symmetric, such as snow-flakes, instead of asymmetric? This issue is a topic of self-organization, as mentioned already in the section of classical physics. It turns out that the symmetry is an automatic result of the way molecular systems grow under the combined influence of diffusion and nonlinear processes. The issue is still a topic of research.

See page 160

▪ A similar breadth of physical and mathematical problems are encountered in the study of liquids and polymers. The ordering of polymer chains, the bubbling of hot water, the motion of heated liquids and the whirls in liquid jets show complex behaviour that can

Ref. 65

be explained with simple models. Turbulence and self-organization will be a fascinating research field for many years to come.

- The ways people handle single atoms with electromagnetic fields is a beautiful example of modern applied technologies. Nowadays it is possible to levitate, to trap, to excite, to photograph, to deexcite, and to move single atoms just by shining light onto them. In 1997, the Nobel prize in physics has been awarded to the originators of the field.

Ref. 66 In 1997, a czech group built a quantum version of the Foucault pendulum, using the superfluidity of helium. In this beautiful piece of research, they cooled a small ring of fluid helium below the temperature of 0.28 K, below which the helium moves without friction. In such situations it thus can behave like a Foucault pendulum. With a clever arrangement, it was possible to measure the rotation of the helium in the ring using phonon signals, and to show the rotation of the earth.

Challenge 882 Ref. 67 If an electrical wire is sufficiently narrow, its electrical conductance is quantized in steps of $2e^2/\hbar$. The wider the wire, the more such steps are added to its conductance. Can you explain the effect? By the way, quantized conductance has also been observed for light and for phonons.

Ref. 68 An example of modern research is the study of hollow atoms, i.e. atoms missing a number of inner electrons. They have been discovered in 1990 by J.P. Briand and his group. They appear when a completely ionized atom, i.e. one without any electrons, is brought in contact with a metal. The acquired electrons then orbit on the outside, leaving the inner shells empty, in stark contrast with usual atoms. Such hollow atoms can also be formed by intense laser irradiation.

- In the past, the description of motion with formulas was taken rather seriously. Before computers appeared, only those examples of motion were studied which could be described with simple formulas. It turned out that Galilean mechanics cannot solve the three-body problem, special relativity cannot solve the two-body problem, general relativity the one-body problem, and quantum field theory the zero-body problem. It took some time to the community of physicists to appreciate that understanding motion does not depend on the description by formulas, but on the description by clear equations based on space and time.

Challenge 899 Can you explain why mud is not clear?

- Photons not travelling parallel to each other attract each other through gravitation, and thus deflect each other. Could two such photons form a bound state, a sort of atom of light, in which they would circle each other, provided there were enough empty space for this to happen?

Challenge 916

Challenge 933

- Can the universe ever have been smaller than its own Compton wavelength?

In fact, quantum electrodynamics, or QED, provides a vast number of curiosities, and every year there is at least one interesting new discovery. We now conclude the theme with a more general approach.

How can one move on perfect ice? – The ultimate physics test

In our quest, we have encountered motion of many sorts. Therefore, the following test – not to be taken too seriously – is the ultimate physics test, allowing to check your understanding and to compare it with that of others.

Imagine that you are on a perfectly frictionless surface, and that you want to move to its border. How many methods can you find to achieve this? Any method, so tiny its effect may be, is allowed.

Classical physics provided quite a number of methods. We saw that for rotating ourselves, we just need to turn our arm above the head. For translation motion, throwing a shoe or inhaling vertically and exhaling horizontally are the simplest possibilities. Can you list at least six additional methods, maybe some using the fact that the surface is located the surface of the earth? What would you do in space?

Challenge 950

Electrodynamics and thermodynamics taught us that in vacuum, heating one side of the body more than the other will work as motor; the imbalance of heat radiation will push you, albeit rather slowly. Are you able to find at least four other methods from these two domains?

Challenge 967

General relativity showed that turning one arm will emit gravitational radiation unsymmetrically, leading to motion as well. Can you find at least two better methods?

Challenge 984

Quantum theory offers a wealth of methods. Of course, quantum mechanics shows that we actually are always moving, since the uncertainty relation makes rest an impossibility. However, the average motion can be zero even if the spread increases with time. Are you able to find at least four methods of moving on perfect ice due to quantum effects?

Challenge 1001

Material science, geophysics, atmospheric physics, and astrophysics also provide ways to move, such as cosmic rays or solar neutrinos. Can you find four additional methods?

Challenge 1018

Self-organization, chaos theory, and biophysics also provide ways to move, when the inner workings of the human body are taken into account. Can you find at least two methods?

Challenge 1035

Assuming that you read already the section following the present one, on the effects of semiclassical *quantum gravity*, here is an additional puzzle: is it possible to move by accelerating a pocket mirror, using the emitted Unruh radiation? Can you find at least two other methods to move yourself using quantum gravity effects? Can you find one from string theory?

Challenge 1052

If you want points for the test, the marking is simple. For students, every working method gives one point. Eight points is ok, twelve points is good, sixteen points is very good, and twenty points or more is excellent.* For graduated physicists, the point is given only when a back-of-the-envelope estimate for the ensuing momentum or acceleration is provided.

Summary of quantum electrodynamics

The shortest possible summary of quantum electrodynamics is the following: *matter is made of charged particles which interact through photon exchange in the way as described by Figure 217.*

In a bit more detail, quantum electrodynamics starts with elementary *particles*, characterized by their mass, their spin and their charge, and with the *vacuum*, essentially a sea of virtual particle-antiparticle pairs. *Interactions* between charged particles are described as the exchange of virtual photons, and *decay* is described as the interaction with the virtual photons of the vacuum.

* The author keeps track of all answers on the <http://www.motionmountain.org> web site.

This is a section of the freely downloadable e-textbook

Motion Mountain

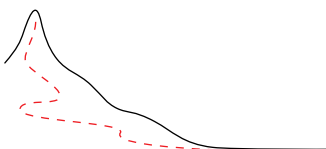

Hiking beyond space and time along the concepts of modern physics

available at
www.motionmountain.org

Copyright © 1997, 1998, 1999, 2000, 2001, 2002 by Christoph Schiller

To the kind reader

In exchange for getting this section for free, I ask you for a short email on some of the following:

- Which page was boring?
- Did you find any mistakes?
- What else were you expecting?
- What was hard to understand?

Of course, any other suggestion is welcome. This section is part of a physics text written over many years. The text lives and grows through the feedback from its readers, who help to improve and to complete it. For a particularly useful contribution (send it in english, italian, dutch, german, spanish, portuguese, or french) you will be mentioned in the foreword of the text, or receive a small reward, or both.

Enjoy!

Christoph Schiller
cs@motionmountain.org

Challenge 1069

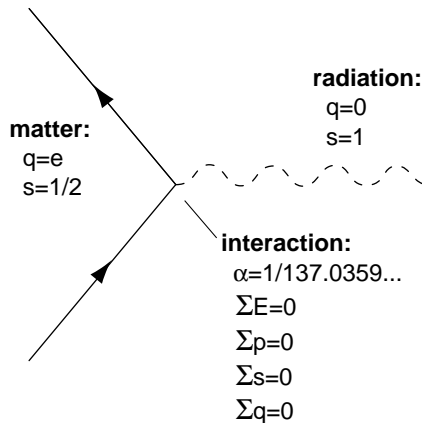

Figure 217 QED as perturbation theory in space-time

As QED is a perturbative theory, the diagram directly describes the first order effects and its composites describe effects of higher order. QED is a perturbative theory.

QED describes all everyday properties of matter and radiation. It describes the *divisibility* down to the smallest constituents, the *isolability* from the environment and the *impenetrability* of matter. It also describes the *penetrability* of radiation. All these properties are due to electromagnetic interactions of constituents and follow from Figure 217. Matter is divisible because the interactions are of finite strength, matter is separable because the interactions are of finite range, and matter is impenetrable because interactions among the constituents increase in intensity when they approach each other, in particular because matter constituents are fermions. Radiation is divisible into photons, and is penetrable because photons are bosons and first order photon-photon interactions do not exist.

Both matter and radiation are made of elementary constituents. These elementary constituents, whether bosons or fermions, are indivisible, isolable, indistinguishable, and point-like.

To describes observations, it is necessary to use quantum electrodynamics in all those situations for which the characteristic dimensions d are of the order of the Compton wavelength

$$d \approx \lambda_C = \frac{h}{m c} . \quad (458)$$

In situations where the dimensions are of the order of the de Broglie wavelength, or equivalently, where the action is of the order of the Planck value, simple quantum mechanics is sufficient:

$$d \approx \lambda_{dB} = \frac{h}{m v} . \quad (459)$$

For larger dimensions, classical physics will do.

Together with gravity, quantum electrodynamics explains almost all observations of motion on earth; QED unifies the description of matter and radiation in daily life. All objects and all images are described by it, including their properties, their shape, their transformations and their other changes. This includes self-organization and chemical or biological. In other words, QED gives us full grasp of the effects and the variety of motion due to electromagnetism.

Open questions in QED

Even though QED describes motion without any discrepancy from experiment, that does not mean that we understand every detail of every example of electric motion. For example, nobody has described the motion of an animal with QED yet.* In fact, there is beautiful and fascinating work going on in many branches of electromagnetism.

Atmospheric physics still provides many puzzles, and regularly delivers new, previously unknown phenomena. For example, the detailed mechanisms at the origin of auroras are still controversial; and the recent unexplained discoveries of discharges *above* clouds should not make one forget that even the precise mechanism of charge separation *inside* clouds, which leads to lightning, is not completely clarified. In fact, all examples of electrification, such as the charging of amber through rubbing, the experiment which gave electricity its name, are still poorly understood.

Material science in all its breadth, including the study of solids, fluids, and plasmas, as well as biology and medicine, still provides many topics of research. In particular, the 21st century will undoubtedly be the century of the life sciences.

The study of the interaction of atoms with intense light is an example of present research in atomic physics. Strong lasers can strip atoms of many of their electrons; for such phenomena, there are not yet precise descriptions, since they do not comply to the weak field approximations usually assumed in physical experiments. In strong fields, new effects take place, such as the so-called Coulomb explosions.

But also the skies have their mysteries. In the topic of cosmic rays, it is still not clear how rays with energies of 10^{22} eV are produced outside the galaxy. Researchers are intensely trying to locate the electromagnetic fields necessary for their acceleration, and to understand their origin and mechanisms.

In the theory of quantum electrodynamics, discoveries are expected by all those who study it in sufficient detail. For example, Dirk Kreimer has found that higher order interaction diagrams built using the fundamental diagram of Figure 217 contain relations to the theory of knots. This research topic will provide even more interesting results in the near future.

Relations to knot theory appear because QED is a *perturbative* description, with the vast richness of its nonperturbative effects still hidden. Studies of QED at high energies, where perturbation is *not* a good approximation and where particle numbers are not conserved, promise a wealth of new insights. We will return to the topic later on.

High energies provide many more questions. So far, the description of motion was based on the idea that measurable quantities can be multiplied and added. This always happens at one space-time point. In mathematical jargon, observables form a *local* algebra. Thus the structure of an algebra contains, implies, and follows from the idea that local properties *lead* to local properties. We will discover later on that this basic assumption is wrong at high energies.

Many other open issues of more practical nature have not been mentioned. Indeed, by far the largest numbers of physicists get paid for some form of applied QED. However, our quest is the description of the *fundamentals* of motion. So far, we have not achieved it. For

* On the other hand, there is beautiful work going on how humans move their limbs; it seems that humans move by combining a small set of fundamental motions.

example, we still need to understand motion in the realm of atomic nuclei. But before we do that, we take a first glimpse of the strange issues appearing when gravity and quantum theory meet.

25. Quantum mechanics with gravitation – first approaches

Gravitation is a weak effect. Every seaman knows it: storms are the worst part of his life, not gravity. Nevertheless, including gravity into quantum mechanics yields a list of important issues.

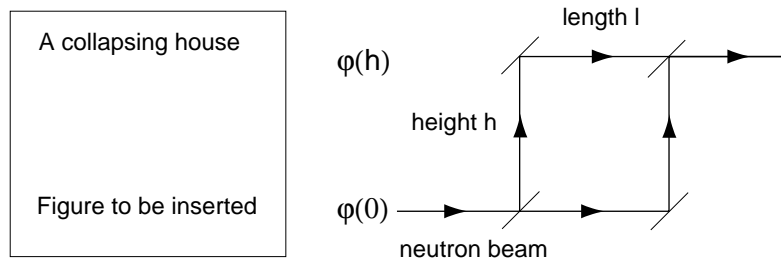

Figure 218 The weakness of gravitation

In the chapter on general relativity we already mentioned that light frequency changes with height. But gravity also changes the *phase* of matter wavefunctions. Can you imagine why? The effect was first confirmed in 1975 with help of neutron interferometers, where neutron beams are brought to interference after having climbed some height h at two different locations. The experiment is shown schematically in Figure 218; it exactly confirmed the predicted phase difference

Challenge 1086

$$\delta\varphi = \frac{mghl}{\hbar v} \quad (460)$$

where l is the distance of the two climbs, and v and m are the speed and mass of the neutrons. These beautifully simple experiments have confirmed the formula within experimental errors.*

Ref. 75

In the 1990s, similar experiments have even been performed with complete atoms. These set-ups allow to build interferometers so sensitive that local gravity g can be measured with a precision of more than eight significant digits.

Ref. 77

Corrections to the Schrödinger equation

In 2002, the first observation of actual quantum states due to gravitational energy was performed. Any particle above the floor should feel the effect of gravity.

Ref. 78

In a few words, one can say that because the experimenters managed to slow down neutrons to the incredibly small value of 8 m/s, using grazing incidence on a flat plate they

* Due to the influence of gravity on phases of wavefunctions, some people who do not believe in bath induced decoherence have even studied their influence on the decoherence process. Predictably, the results have not convinced.
Ref. 76

could observe how neutrons climbed and fell back due to gravity with speeds below a few cm/s.

Obviously, the quantum description is a bit more involved. The lowest energy level for neutrons due to gravity is $2.3 \cdot 10^{-31}$ J, or 1.4 peV. To get an impression of its smallness, we can compare it to the value of $2.2 \cdot 10^{-18}$ J or 13.6 eV for the lowest state in the hydrogen atom.

A rephrased large number hypothesis

Despite its weakness, gravitation provides many puzzles. Most famous are a number of curious coincidences that can be found when quantum mechanics and gravitation are combined. They are usually called ‘large number hypotheses’ because they usually involve large dimensionless numbers. A pretty, but less well known version connects the Planck length,

Ref. 95 the cosmic horizon, and the number of baryons:

$$(N_b)^3 \approx \left(\frac{R_o}{l_{Pl}}\right)^4 = \left(\frac{t_o}{t_{Pl}}\right)^4 \approx 10^{244} \quad (461)$$

in which $N_b = 10^{81}$ and $t_o = 1.2 \cdot 10^{10}$ a were used. There is no known reason why the number of baryons and the horizon size should be related in this way. This coincidence is equivalent to the one originally stated by Dirac, * namely

$$m_p^3 \approx \frac{\hbar^2}{Gct_o} \quad (463)$$

where m_p is the proton mass. This approximate equality seems to suggest that certain microscopic properties, namely the mass of the proton, is connected to some general properties of the universe as a whole. This has led to numerous speculations, especially since the time dependence of the two sides differs. Some people even speculate whether relations (461) or (463) express some long-sought relation between local and global topological properties

Ref. 97 of nature. Up to this day, the only correct statement seems to be that they are *coincidences* connected to the time at which we happen to live. But gravity also leads to other quantum surprises.

Limits to disorder

Die Energie der Welt ist constant.

Die Entropie der Welt strebt einem Maximum zu. **

Ref. 96 * The equivalence can be deduced using $Gn_b m_p = 1/t_o^2$, which, as Weinberg explains, is required by several cosmological models. Indeed, this can be rewritten simply as

$$m_o^2/R_o^2 \approx m_{Pl}^2/R_{Pl}^2 = c^4/G^2 \quad (462)$$

Together with the definition of the baryon density $n_b = N_b/R_o^3$ one gets Dirac’s large number hypothesis, substituting protons for pions. Note that the Planck time and length are defined as $\sqrt{\hbar G/c^5}$ and $\sqrt{\hbar G/c^3}$ and are the natural units of length and time. We will study them in detail in the third part of the mountain ascent.

** The energy of the universe is constant. Its entropy tends towards a maximum.

Rudolph Clausius

We have already encountered the famous statement by Claudius, the father of the term ‘entropy’. Strangely, for over hundred years nobody asked whether there is a theoretical maximum for entropy. This changed in 1973, when Jakob Bekenstein found the answer while investigating the consequences gravity has for quantum physics. He found that the entropy of an object of energy E and size L is bound by

See page 305

Ref. 79

$$S \leq EL \frac{k\pi}{\hbar c} \quad (464)$$

for all physical systems. In particular, he deduced that (nonrotating) black holes saturate the bound, with an entropy given by

Challenge 1103

$$S = \frac{kc^3}{G\hbar} \frac{A}{4} = \frac{kG}{\hbar c} 4\pi M^2 \quad (465)$$

where A is now the area of the *horizon* of the black hole given by $A = 4\pi R^2 = 4\pi(2GM/c^2)^2$. In particular, the result implies that every black hole has an entropy. Black holes are thus disordered systems described by thermostatics. In addition, they are the most disordered systems known.

As an interesting note, the maximum entropy also gives a memory limit for memory chips. Can you find out how?

Challenge 1120

Which are the different microstates leading to this macroscopic entropy? It took many years to convince physicists that the microstates have to do with the various possible states of the horizon itself, and that they are due to the diffeomorphism invariance at this boundary. As ‘t Hooft explains, the entropy expression implies that the number of degrees of freedom of a black hole is about (but not exactly) one per Planck area of the horizon.

Ref. 80

Challenge 16

If black holes have entropy, they must have a temperature. What does this temperature mean? In fact, nobody believed this conclusion until two unrelated developments confirmed it within a few months. All these results were waiting to be discovered since the 1930s, even though, incredibly, nobody had thought about them for over 40 years.

How to measure acceleration with a thermometer – Davies-Unruh radiation

In 1973, Paul Davies and William Unruh independently made a theoretical discovery: if an inertial observer observes that he is surrounded by vacuum, a second observer *accelerated* with respect to the first does not: he observes black body radiation, with a spectrum corresponding to the temperature

Ref. 81

$$T = a \frac{\hbar}{2\pi kc} \quad (466)$$

The result also means that there is no vacuum on earth, because an observer on its surface can maintain that he is accelerated with 9.8 m/s^2 , thus leading to $T = 40 \text{ zK}$! We can thus measure gravity, at least in principle, using a thermometer. However, even for the largest practical accelerations the temperature values are so small that it is questionable whether the effect will ever be confirmed experimentally.

Ref. 82

When this effect was discovered, people studied it from all sides. For example, it was found that the acceleration of a *mirror* leads to radiation emission! Mirrors are thus harder to accelerate than other bodies of the same mass.

When the acceleration is high enough, also *matter* particles can be detected. If a particle counter is accelerated sufficiently strongly across the vacuum, it will start counting particles! We see that the difference between vacuum and matter becomes fuzzy at large energies.

For completeness, we mention that also an observer in rotational motion detects radiation following expression (466).

Black holes aren't black

In 1974, the English physicist Stephen Hawking, famous for the courage with which he fights a disease which forces him into the wheelchair, surprised the world of general relativity with a fundamental theoretical discovery. He found that if a virtual particle-antiparticle pair appeared in the vacuum near the horizon, there is a finite chance that one particle escapes as a real particle while the antiparticle is captured by the black hole. This true both for fermions and for bosons. From far away this effect looks like the emission of a particle. Hawking's detailed investigation showed that that black holes radiate as black bodies.

Black hole radiation confirms both the effect noticed by accelerated observers as the result on black hole entropy by Bekenstein. When all this became clear, a beautiful Gedankenexperiment (thought experiment) was published by William Unruh and Robert Wald, showing that the whole result could have been deduced already 50 years before!

Shameful as this delay of the discovery is for theoretical physicists, the story itself remains beautiful. It starts in the early 1970s, when Robert Geroch had studied the issue shown in Figure 219. Imagine a box full of heat radiation - light. The mass of the box is assumed to be negligible, such as a box made of aluminium paper. We lower the box, with all its contained radiation, from a space station towards a black hole. On the space station, lowering the weight of the heat radiation allows to generate energy. Obviously, when the box reaches the black hole horizon, the heat radiation is red shifted to infinite wavelength. At that point, the full amount of energy originally contained in the heat radiation has been provided to the space station. We can now do the following: we can open the box on the horizon, let drop out whatever is still inside, and wind the empty and massless box back up again. As a result, we have

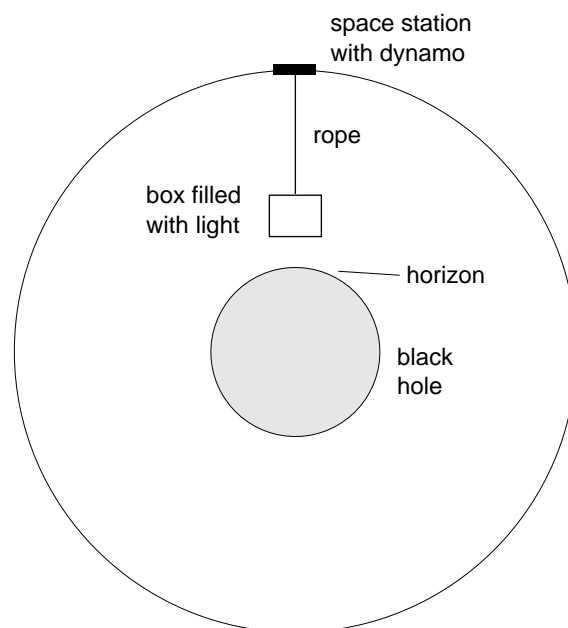

Figure 219 A *Gedankenexperiment* allowing to deduce the existence of black hole radiation

completely converted heat radiation into mechanical energy. Nothing else has changed: the black hole has the same mass as beforehand.

But this result contradicts the second principle of thermodynamics! Geroch concluded that something must be wrong. We must have forgotten an effect which makes this process impossible.

In the 1980s, Unruh and Wald showed that black hole radiation is precisely the forgotten effect that puts everything right again. Because of black hole radiation, the box feels buoyancy, so that it cannot be lowered down to the horizon. It floats somewhat above it, so that the heat radiation inside the box has not yet *zero* energy when it falls out of the opened box. As a result, the black hole does increase in mass, and thus in entropy. In summary, when the empty box is pulled up again, the final situation is thus the following: only part of the energy of the heat radiation has been converted into mechanical energy, part of the energy went into the increase of mass and thus of entropy of the black hole. The second principle of thermodynamics is saved.

Well, it is only saved if the heat radiation has the right energy density at the horizon and above. Let us have a look.

– CS – to be completed – CS –

Hawking found the same result by his own calculation method. The so-called Hawking temperature of a black hole of mass M turns out to be

$$T = \frac{\hbar c^3}{8\pi kGM} = \frac{\hbar}{2\pi kc} g_{\text{surf}} \quad \text{with} \quad g_{\text{surf}} = \frac{c^4}{4GM} . \quad (467)$$

For example, a black hole with the mass of the sun would have the rather small temperature of 62 nK, whereas a smaller black hole with the mass of a mountain, say 10^{12} kg, would have a temperature of 123 GK. That would make quite a good oven. All known black hole candidates have masses in the range from a few to a few million solar masses. The radiation is thus extremely weak, also because the emitted wavelength is of the order of the black hole radius, as you might want to check. The radiation of black holes is often also called *Bekenstein-Hawking radiation*.

Challenge 33

This rather academic effect leads to a luminosity

Challenge 50

$$L \sim \frac{1}{M^3} \quad \text{or} \quad L = nA\sigma T^4 = \frac{n\pi^3 k^4}{15c^2 \hbar^3} T^4 \quad (468)$$

where n is the number of particle degrees of freedom that can be radiated; if only photons are radiated, we have $n = 2$. (Actually, massless neutrinos are emitted more frequently than photons.) *Black holes thus shine*, and the more the smaller they are. This is a genuine *quantum* effect, since classically, black holes cannot emit any light.

Ref. 84

Due to the emitted radiation, black holes gradually lose mass. Therefore their theoretical lifetime is *finite*. A short calculation shows that it is given by

Challenge 67

$$t = M^3 \frac{20\,480\pi G^2}{\hbar c^4} \approx M^3 3.4 \cdot 10^{-16} \text{ s/kg}^3 \quad (469)$$

as function of their initial mass M . For example, a black hole with mass of 1 gram would have a lifetime of $3.4 \cdot 10^{-25}$ s, whereas a black hole of the mass of the sun, $2.0 \cdot 10^{30}$ kg, would have a lifetime of about 10^{68} years. Obviously, these numbers are purely academic. In any case, *black holes evaporate*. However, this extremely slow process for usual black holes determines their lifetime only if no other, faster process comes into play. We will present a few such processes shortly. Hawking radiation is the weakest of all known effects. It is not masked by stronger effects only if the black hole is non-rotating, electrically neutral and with no matter falling into it from the surroundings.

So far, none of these quantum gravity effects has been confirmed experimentally, as the values are much too small to be detected. However, the deduction of a Hawking temperature has been beautifully confirmed by a theoretical discovery of Unruh, who found that there are configurations of fluids in which sound waves cannot escape, so-called ‘*silent holes*’. Consequently, these silent holes radiate sound waves with a temperature satisfying the same formula as real black holes. A second type of analogue system, namely *optical black holes*, are also being investigated.

In 1975, a much more dramatic radiation effect than black hole radiation was predicted for *charged* black holes by Damour and Ruffini. Charged black holes have a much shorter lifetime than just presented, because during their formation a second process takes place. In a region surrounding them the electric field is larger than the so-called vacuum polarization value, so that large numbers of electron-positron pairs are produced, which then almost all annihilate. This process effectively reduces the charge of the black hole to a value for which the field is below critical everywhere, while emitting large amounts of high energy light. It turns out that the mass is reduced by up to 30% in a time of the order of seconds. That is quite shorter than 10^{68} years. This process thus produces an extremely intense *gamma ray burst*.

Such gamma ray bursts had been discovered in the late 1960s by military satellites which were trying to spot nuclear explosions around the world through their gamma ray emission. The satellites found about two such bursts per day, coming from all over the sky. Another satellite, the Compton satellite, confirmed that they were extragalactic in origin, and that their duration varied between a sixtieth of a second and about a thousand seconds. In 1996, the Italian-Dutch BeppoSAX satellite started mapping and measuring gamma ray bursts systematically. It discovered that they were followed by an *afterglow* in the X-ray domain of many hours, sometimes of days. In 1997 afterglow was discovered also in the optical domain. The satellite also allowed to find the corresponding X-ray, optical, and radio sources for each burst. These measurements in turn allowed to determine the distance of the burst sources; red shifts between 0.0085 and 4.5 were measured. In 1999 it also became possible to detect *optical* bursts corresponding to the gamma ray ones. *

All this data together shows that the gamma ray bursts have energies ranging from 10^{40} W to $3 \cdot 10^{47}$ W. The larger value is (almost) the same brightness as that of all stars of the whole visible universe taken together! Put differently, it is the same amount of energy that is released when converting several solar masses into radiation within a few seconds. In fact, the measured luminosity is near the theoretical maximum luminosity a body can have. This

* For more about this fascinating topic, see the <http://www.aip.de/~jcg/grb.html> web site by Jochen Greiner.

Challenge 84

limit is given by

$$L < L_{\text{Pl}} = \frac{c^5}{2G} = 1.8 \cdot 10^{52} \text{ W} \quad , \quad (470)$$

as you might want to check yourself. In short, the sources of gamma ray bursts are the biggest bombs found in the universe. In fact, more detailed investigations of experimental data confirm that gamma ray bursts are ‘primal screams’ of black holes in formation.

Challenge 101

Ref. 89

With all this new data, Ruffini took up his 1975 model again in 1997, and with his collaborators showed that the gamma ray bursts generated by the annihilation of electron-positrons pairs created by vacuum polarization, in the region they called the *dyadosphere*, have a luminosity and a duration exactly as measured, if a black hole of about a few up to 30 solar masses is assumed. Charged black holes therefore reduce their charge and mass through the vacuum polarization and electron positron pair creation process. (The process reduces the mass because it is one of the few processes which is *reversible*; in contrast, most other attempts to reduce charge on a black hole, e.g. by throwing in a particle with the opposite charge, increase the mass of the black hole, and are thus irreversible.) The left over remnant then can lose energy in various ways, and also turns out to be responsible for the afterglow discovered by the BeppoSAX satellite. Among others, Ruffini’s team speculates that the remnants are the sources for the high energy cosmic rays, whose origin had not been localized so far. All these exciting studies are still ongoing.

Ref. 90

Other processes leading to emission of radiation appear when matter falls into the black hole and heats up, when matter is ejected from rotating black holes through the Penrose process, or when charged particles fall into the black hole. These mechanisms are at the origin of *quasars*, the extremely bright quasi-stellar sources found all over the sky. They are assumed to be black holes surrounded by matter, in the development stage following gamma ray bursters. The details of what happens in quasars, the enormous voltages (up to 10^{20} V) and magnetic fields generated, as well as their effects on the surrounding matter are still object of intense research in astrophysics.

See page 320

Black hole material properties

Once the concept of entropy of a black hole was established, people started to think about black holes like about any other material. For example, black holes have a matter density, which can be defined by relating their mass to a fictitious volume defined by $4\pi R^3/3$. This density is given by

$$\rho = \frac{1}{M^2} \frac{3c^6}{32\pi G^3} \quad (471)$$

and can be quite low for large black holes. For the highest black holes known, with 1000 million solar masses or more, the density is of the order of the density of air. By the way, the gravitational acceleration at the horizon is still appreciable, as it is given by

$$g_{\text{surf}} = \frac{1}{M} \frac{c^4}{4G} = \frac{c^2}{2R} \quad (472)$$

which is still 15 km/s^2 for an air density black hole.

Challenge 118

Obviously, the black hole temperature is related to the entropy by its usual definition

$$\frac{1}{T} = \left. \frac{\partial S}{\partial E} \right|_{\rho} = \left. \frac{\partial S}{\partial(Mc^2)} \right|_{\rho} \quad (473)$$

All other thermal properties can be deduced by the standard relations from thermostatics.

Challenge 135 In particular, it looks as if black holes are the matter states with the largest possible entropy. Can you confirm this statement?

It also turns out that black holes have a *negative* heat capacity: when heat is added, they cool down. In other words, black holes cannot achieve equilibrium with a bath. This is not a real surprise, since *any* gravitationally bound material system has negative specific heat. Indeed, it takes only a bit of thinking to see that any gas or matter system collapsing under gravity follows $dE/dR > 0$ and $dS/dR > 0$. That means that while collapsing, the energy and the entropy of the system shrink. (Can you find out where they go?) Since temperature is defined as $1/T = dS/dE$, temperature is always positive; from the temperature increase $dT/dR < 0$ during collapse one deduces that the specific heat dE/dT is negative.

Challenge 152

Challenge 169

Ref. 92

Ref. 84

Ref. 91

Nonrotating black holes have no magnetic field, as was established already in the 1960s by Russian physicists. On the other hand, black holes have something akin to a finite electrical conductivity and a finite viscosity. Some of these properties can be understood if the horizon is described as a membrane, even though this model is not always applicable. In any case, one can study and describe macroscopic black holes like any other macroscopic material body. The topic is not closed.

How do black holes evaporate?

When a nonrotating and uncharged black hole loses mass by radiating Hawking radiation, eventually its mass reaches values approaching the Planck mass, namely a few micrograms. Expression (469) for the lifetime, applied to a black hole of Planck mass, yields a value of over sixty thousand Planck times. A surprising large value. What happens in those last instants of evaporation?

A black hole approaching the Planck mass at some time will get smaller than its own Compton wavelength; that means that it behaves like an elementary particle, and in particular, that quantum effects have to be taken into account. It is still unknown how these final evaporation steps take place, whether the mass continues to diminish smoothly or in steps (e.g. with mass values decreasing as \sqrt{n} when n approaches zero), how its internal structure changes, whether a stationary black hole starts to rotate (as the author predicts), how the emitted radiation deviates from black body radiation. There is still enough to study. However, one important issue *has* been settled.

The information paradox of black holes

When the thermal radiation of black holes was discovered, one question was hotly debated for many years. The matter forming a black hole can contain lots of information; e.g., imagine the black hole formed by a large number of books collapsing onto each other. On the other hand, a black hole radiates thermally until it evaporates. Since thermal radiation carries no information, it seems that information somehow disappears, or equivalently, that entropy increases.

An incredible number of papers have been written about this problem, some even claiming that this example shows that physics as we know it is incorrect and needs to be changed. As usual, to settle the issue, we need to look at it with precision, laying all prejudice aside. Three intermediate questions can help us finding the answer.

- What happens when a book is thrown into the sun? When and how is the information radiated away?
 - How precise is the sentence that black hole radiate *thermal* radiation? Could there be a slight deviation?
 - Could the deviation be measured? In what way would black holes radiate information?
- You might want to make up your own mind before reading on.

Challenge 186

Let us walk through a short summary. When a book or any other highly complex – or low entropy – object is thrown into the sun, the information contained is radiated away. The information is contained in some slight deviations from black hole radiation, namely in slight correlations between the emitted radiation emitted over the burning time of the sun. A short calculation, comparing the entropy of a room temperature book and the information contained in it, shows that these effects are extremely small and difficult to measure.

A clear exposition of the topic was given by Don Page. He calculated what information would be measured in the radiation if the the system of black hole and radiation *together* would be in a *pure* state, i.e. a state containing specific information. The result is simple. Even if a system is large – consisting of many degrees of freedom – and in pure state, any smaller *subsystem* nevertheless looks almost perfectly thermal. More specifically, if a total system has a Hilbert space dimension $N = nm$, where n and $m \leq n$ are the dimensions of two subsystems, and if the total system is in a pure state, the subsystem m would have an entropy S_m given by

Ref. 93

Challenge 203

$$S_m = \frac{1-m}{2n} + \sum_{k=n+1}^{mn} \frac{1}{k} \quad (474)$$

which is approximately given by

$$S_m = \ln m - \frac{m}{2n} \quad \text{for } m \gg 1 \quad . \quad (475)$$

To discuss the result, let us think of n and m as counting degrees of freedom, instead of Hilbert space dimensions. The first term in equation (475) is the usual entropy of a mixed state. The second term is a small deviation and describes the amount of specific information contained in the original pure state; inserting numbers, one finds that it is extremely small compared to the first. In other words, the subsystem m is almost indistinguishable from a mixed state; it looks like a thermal system even though it is not.

A calculation shows that the second, small term on the right of equation (475) is indeed sufficient to radiate away, during the lifetime of the black hole, any information contained in it. Page then goes on to show that the second term is so small that not only it is lost in measurements; it is also lost in the usual, perturbative calculations for physical systems.

The question whether any radiated information could be measured can now be answered directly. As Don Page showed, even measuring half of the system only gives about 1/2 bit of that information. It is necessary to measure the complete system to measure all the

Ref. 94

contained information. In summary, at a given instant, the amount of information radiated by a black hole is negligible when compared with the total black hole radiation, and is practically impossible to detect by measurements or even by usual calculations.

More paradoxes

A black hole is a macroscopic object, similar to a star. Like all objects, it can interact with its environment. It has the special property to swallow everything that falls into them. This immediately leads us to ask if we can use this property to cheat around the usual everyday ‘laws’ of nature. Some attempts have been studied in the section on general relativity and above; here are a few more.

See page 322

▪ Apart from the questions of entropy, we can look for methods to cheat around conservation of energy, angular momentum, or charge. Every Gedankenexperiment comes to the same conclusions. No cheats are possible; in addition, the maximum number of degrees of freedom in a region is proportional to the surface area of the region, and *not* to its volume. This intriguing result will keep us busy for quite some time.

Challenge 220

▪ If a twin falls into a large black hole, according to general relativity he makes no special observations. However, in his brother’s view he burns on the horizon. As explained before, while burning, he – or his ashes – also spread all over the horizon. We thus find a strange situation: adding quantum theory to the study of black holes shows that in contrast to what general relativity says, there is no way to cross the horizon unharmed. Quantum theory and general relativity contradict each other. We will study more such puzzles later on.

Challenge 237

▪ A black hole transforms matter into antimatter with a certain efficiency. Thus one might look for departures from particle number conservation. Are you able to find an example?

Challenge 254

Quantum mechanics of gravitation

Let us take a conceptual step at this stage. So far, we looked at quantum theory *with* gravitation; now we have a glimpse at quantum theory *of* gravitation.

If we focus on the similarity between the electromagnetic field and the gravitational ‘field,’ we should try to find the quantum description of the latter. Despite attempts by many brilliant minds for almost a century, this approach was not successful.* Let us see why.

The gravitational Bohr atom

A short calculation shows that an electron circling a proton due to gravity alone, without electrostatic attraction, would do so at a gravitational Bohr radius of

Challenge 271

$$r_{\text{gr.B.}} = \frac{\hbar^2}{Gm_e^2 m_p} = 1.1 \cdot 10^{29} \text{ m} \quad (476)$$

which is about a thousand times the distance to the cosmic horizon. In fact, even in the normal hydrogen atom there is not a *single way* to measure gravitational effects. (Are you able to confirm this?) But why is gravity so weak? Or equivalently, why are the universe and normal atoms so much smaller than a gravitational Bohr atom? At the present point of

Challenge 288

* Modern approaches take another direction, as explained in the third part of the mountain ascent.

our quest these questions cannot be answered. Worse, the weakness of gravity even means that with high probability, future experiments will provide little additional data helping to decide among competing answers. The only help is careful thought.

Decoherence of space-time

If the gravitational field evolves like a quantum system, we encounter all issues found in other quantum systems. General relativity taught us that the gravitational field and space-time are the same. As a result, we may ask why no superpositions of different macroscopic space-times are observed.

The discussion is simplified for the simplest case of all, namely the superposition, in a vacuum region of size l , of a homogenous gravitational field with value g and one with value g' . As in the case of a superposition of macroscopic distinct wavefunctions, such a superposition *decays*. In particular, it decays when particles cross the volume. A short calculation yields a decay time given by

$$t_d = \left(\frac{2kT}{\pi m}\right)^{3/2} \frac{nl^4}{(g-g')^2} \quad , \quad (477)$$

where n is the particle number density, kT their kinetic energy, and m their mass. Inserting typical numbers, we find that the variations in gravitational field strength are *extremely* small. In fact, the numbers are so small that we can deduce that the gravitational field is the *first* variable which behaves classically in the history of the universe. Quantum gravity effects for space-time will thus be extremely hard to detect.

In short, matter not only tells space-time how to curve, it also tells it to behave with class. This result calls for the following question.

Do gravitons exist?

Quantum theory says that everything that moves is made of particles. What kind of particles are gravitational waves made of? If the gravitational field is to be treated quantum mechanically like the electromagnetic field, its waves should be quantized. Most properties of these quanta can be derived in a straightforward way.

The $1/r^2$ dependence of universal gravity, like that of electricity, implies that the particles have *vanishing* mass and move at light speed. The independence of gravity from electromagnetic effects implies a *vanishing* electric charge.

The observation that gravity is always attractive, never repulsive, means that the field quanta have *integer* and *even* spin. Vanishing spin is ruled out, since it implies no coupling to energy. To comply with the property that 'all energy has gravity', $S = 2$ is needed. In fact, it can be shown that *only* the exchange of a massless spin 2 particle leads, in the classical limit, to general relativity.

The coupling strength of gravity, corresponding to the fine structure constant of electromagnetism, is given either by

$$\alpha_{G1} = \frac{G}{\hbar c} = 2.2 \cdot 10^{-15} \text{ kg}^{-2} \quad \text{or by} \quad \alpha_{G2} = \frac{Gmm}{\hbar c} = \left(\frac{m}{m_{\text{Pl}}}\right)^2 = \left(\frac{E}{E_{\text{Pl}}}\right)^2 \quad (478)$$

However, the first expression is not a pure number; the second expression is, but depends on the mass one inserts. These difficulties reflect the fact that gravity is not properly speaking an interaction, as became clear in the section on general relativity. It is often argued that m should be taken as the value corresponding to the energy of the system in question. For everyday life, typical energies are 1 eV, leading to a value $\alpha_{G2} \approx 1/10^{56}$. Gravity is indeed weak compared to electromagnetism, for which $\alpha_{em} = 1/137.04$.

If all this is correct, *virtual* field quanta would also have to exist, to explain static gravitational fields.

Challenge 339

However, up to this day, the so-called *graviton* has not yet been detected, and there is in fact little hope that it ever will. On the experimental side, nobody knows yet how to build a graviton detector. Just try! On the theoretical side, the problems with the coupling constant probably make it impossible to construct a *renormalizable* theory of gravity; the lack of renormalization means the impossibility to define a perturbation expansion, and thus to define particles, including the graviton. In summary, it may be that the particle concept has to be changed before applying quantum theory to gravity. The issue is still open at this point.

Space-time foam

The indeterminacy relation for momentum and position also applies to the gravitational field. As a result, it leads to an expression for the indeterminacy of the metric tensor g in a region of size L , which is given by

$$\Delta g \approx 2 \frac{l_{Pl}^2}{L^2} \quad , \quad (479)$$

Challenge 356

where $l_{Pl} = \sqrt{\hbar G/c^3}$ is the Planck length. Can you deduce the result? Quantum theory thus shows that like the momentum or the position of a particle, also the metric tensor g is a *fuzzy* observable.

But that is not all. Quantum theory is based on the principle that actions below $\hbar/2$ cannot be observed. This implies that the observable values for the metric g in a region of size L are bound by

$$g \geq \frac{2\hbar G}{c^3} \frac{1}{L^2} \quad . \quad (480)$$

Can you confirm this? The result has far-reaching consequences. A minimum value for the metric depending inversely on the region size implies that it is impossible to say what happens to the shape of space-time at extremely small dimensions. In other words, at extremely high energies, the concept of space-time itself becomes fuzzy. John Wheeler introduced the term *space-time foam* to describe this situation. The term makes clear that space-time is not continuous nor a manifold in those domains. But this was the basis on which we built our description of nature so far! We are forced to deduce that our description of nature is build on sand. This issue will form the start of the third part of our mountain ascent.

See page 671

No particles

Gravity has another important consequence for quantum theory. To count and define particles, quantum theory needs a defined vacuum state. However, the vacuum state cannot be defined when the curvature radius of space-time, instead of being larger than the Compton wavelength, becomes comparable to it. In such highly curved space-times, particles cannot be defined. The reason is the impossibility to distinguish the environment from the particle in these situations: in the presence of strong curvatures, the vacuum is full of spontaneously generated matter, as black holes show. Now we just saw that at small dimensions, space-time fluctuates wildly; in other words, space-time is highly curved at small dimensions or high energies. In other words, strictly speaking particles cannot be defined; the particle concept is only a low energy approximation! We will explore this strange conclusion in more detail in the third part of our mountain ascent.

See page 521

No cheating any more

This short excursion into the theory of quantum gravity showed that a lot of trouble is waiting. The reason is that up to now, we deluded ourselves. In fact, it was more than that: we cheated. We carefully hid a simple fact: quantum theory and general relativity *contradict* each other. That was the real reason that we stepped back to special relativity before we started exploring quantum theory. In this way we avoided all problems, as quantum theory does not contradict *special* relativity. However, it does contradict *general* relativity. The issues are so dramatic, changing everything from the basis of classical physics to the results of quantum theory, that we devote the beginning of the third part only to the exploration of the contradictions. There will be surprising consequences on the nature of space-time, particles and motion. But before we study these issues, we complete the theme of the the present, second part of the mountain ascent, namely the essence of matter and interactions.



References

- 1 See e.g. the reprints of his papers in the standard collection by J.A. WHEELER & W.H. ZUREK, *Quantum theory and measurement*, Princeton University Press, 1983. Cited on page 539.
- 2 H.D. ZEH, *On the interpretation of measurement in quantum theory*, Foundations of Physics **1**, pp. 69–76, 1970. Cited on page 539.
- 3 LINDA REICHL, *A modern course in statistical physics*, Wiley, 2nd edition, 1998. An excellent introduction into thermodynamics. Cited on page 540.
- 4 E. JOOS & H.D. ZEH, *The emergence of classical properties through interactions with the environment*, Zeitschrift für Physik B **59**, pp. 223–2443, 1985. Cited on page 542.
- 5 M. TEGMARK, *Apparent wave function collapse*, Foundation of Physics Letters, **6**, pp. 571–590, 1993. Cited on page 542.
- 6 The decoherence time is bound from above by the relaxation time. See A.O. CALDEIRA & A.J. LEGGETT, *Influence of damping on quantum interference: an exactly soluble model*,

- Physical Review A **31**, 1985, pp. 1059–1066. This is the main reference about effects of decoherence for a harmonic oscillator. The general approach to relate decoherence to the influence of the environment is due to Niels Bohr, and has been pursued in detail by Dieter Zeh. Cited on page [542](#).
- 7** G. LINDBLAD, *On the generators of quantum dynamical subgroups*, Communications on Mathematical Physics **48**, pp. 119–130, 1976. Cited on page [544](#).
 - 8** WOJCIECH H. ZUREK, *Decoherence and the transition from quantum to classical*, Physics Today pp. 36–44, October 1991. An easy but somewhat confusing article. His reply to the numerous letters of response in Physics Today, April 1993, pp. 13–15, and pp. 81–90, exposes his ideas in a clearer way, and gives a taste of the heated discussions on this topic. Cited on page [544](#), [548](#).
 - 9** JOHN BARDEEN, his talk in Japan. Cited on page [545](#).
 - 10** The first decoherence measurement was performed by M. BRUNE & S. HAROCHE, Physical Review Letters 9 December 1996. Cited on page [545](#).
 - 11** K. BAUMANN, *Quantenmechanik und Objektivierbarkeit*, Zeitschrift für Naturforschung **25a**, pp. 1954–1956, 1970. Cited on page [545](#).
 - 12** DAVID BOHM, *Quantum Theory*, Prentice-Hall, 1951, pp. 614–622. Cited on page [547](#).
 - 13** ALBERT EINSTEIN, BORIS PODOLSKY & NATHAN ROSEN, *Can quantum-mechanical description of reality be considered complete?*, Physical Review **48**, pp. 696–702, 1935. Cited on page [547](#).
 - 14** ALAIN ASPECT, J. DALIBARD & G. ROGER, *Experimental tests of Bell's inequalities using time-varying analysers*, Physical Review Letters **49**, pp. 1804–1807, 1982. Cited on page [547](#).
 - 15** JOHN MADDOX, ... Cited on page [548](#).
 - 16** On the superposition of magnetization in up and down directions there are numerous papers. Recent experiments on the subject of quantum tunneling in magnetic systems are described in D.D. AWSCHALOM, J.F. SMITH, G. GRINSTEIN, D.P. DIVICENZO & D. LOSS, *Macroscopic quantum tunneling in magnetic proteins*, Physical Review Letters **88**, pp. 3092–3095, 1992, and in C. PAULSEN & al., *Macroscopic quantum tunneling effects of Bloch walls in small ferromagnetic particles*, Europhysics Letters **19**, pp. 643–648, 1992. Cited on page [548](#).
 - 17** The prediction that quantum tunneling could be observable when the dissipative interaction with the rest of the world is small enough was made by Leggett; the topic is reviewed in A.J. LEGGETT, S. CHAHRAVARTY, A.T. DORSEY, M.P.A. FISHER, A. GARG & W. ZWERGER, *Dynamics of dissipative 2-state systems*, Review of Modern Physics **59**, pp. 1–85, 1987. Cited on page [551](#).
 - 18** For example, superpositions were observed in Josephson junctions by R.F. VOSS & R.A. WEBB, *Macroscopic quantum tunneling in 1 mm Nb Josephson junctions*, Physical Review Letters **47**, pp. 265–268, 1981, Cited on page [548](#).
 - 19** S. HAROCHE, *Entanglement, decoherence, and the quantum-classical transition*, Physics Today **51**, pp. 36–42, July 1998. An experiment putting atom at two places at once, distant about 80 nm, was published by C. MONROE & al., Science **272**, p. 1131, 1996. Cited on page [548](#).
 - 20** M.R. ANDRES & al., *Observations of interference between two Bose condensates*, Science **275**, pp. 637–641, 31 January 1997. See also the www.aip.org/phynews/special.htm web site. Cited on page [548](#).
 - 21** The most famous reference on the wave function collapse is chapter IV of the book by KURT GOTTFRIED, *Quantum mechanics*, Benjamin, New York, 1966, It is the favorite reference

- by Victor Weisskopf, and cited by him on every occasion he talks about the topic. Cited on page 550.
- 22 The first experimental measurement of superpositions of left and right flowing currents is ... In the year 2000, superpositions of 1 μ A clockwise and anticlockwise have been detected; for more details, see J.R. FRIEDMAN & al., *Quantum superposition of distinct macroscopic states*, Nature **406**, p. 43, 2000. Cited on page 548.
 - 23 Collapse times have been measured ... Cited on page 553.
 - 24 S. KOCHEN & E.P. SPECKER, *The problem of hidden variables in quantum mechanics*, **17**, pp. 59–87, 1967. Cited on page 553.
 - 25 J.F. CLAUSER, M.A. HORNE, A. SHIMONY & R.A. HOLT, Physical Review Letters **23**, p. 880, 1969. The more general and original result is found in J.S. BELL, Physics **1**, p. 195, 1964, Cited on page 554.
 - 26 Bryce de WITT & al., *The many-worlds interpretation of quantum mechanics*, Princeton University Press, 1973. This interpretation talks about entities which cannot be observed, namely the many worlds, and often assumes that the wavefunction of the universe exists. Both habits are beliefs, and in contrast with facts. Cited on page 556.
 - 27 M. TEGMARK, *The importance of quantum decoherence in brain processes*, Physical Review D **61**, pp. 4194–4206, 2000, or also <http://arxiv.org/quant-ph/9907009>. Cited on page 557.
 - 28 E. FERMI, *Quantum theory of radiation*, Review of Modern Physics **4**, p. 87, 1932. Cited on page .
 - 29 G. HEGERFELDT, *Causality problems for Fermi's two-atom system*, Physical Review Letters **72**, pp. 596–599, 1994, Cited on page .
 - 30 The beautiful analogy between optics and two-dimensional electron systems, in GaAs at helium temperature, has been studied in detail by C.W.J. BEENAKKER & H. VAN HOUTEN, for example in their review in *Solid State Physics*, **44**, pp. 1–228, 1991, Cited on page .
 - 31 The use of radioactivity for breeding is described by ... Cited on page 559.
 - 32 S.M. BLOCK, *Real engines of creation*, Nature **386**, pp. 217–219, 1997. Cited on page 560.
 - 33 Early results and ideas on molecular motors are summarized by BARBARA GOSS LEVI, *Measured steps advance the understanding of molecular motors*, Physics Today pp. 17–19, April 1995. Newer results are described in R.D. ASTUMIAN, *Making molecules into motors*, Scientific American pp. 57–64, July 2001. Cited on page 560, 561.
 - 34 R. BARTUSSEK & P. HÄNGGI, *Brownsche Motoren*, Physikalische Blätter **51**, pp. 506–507, 1995. Cited on page 561.
 - 35 The motorized screw used by viruses was described by, Nature **408**, p. 745, 2000. Cited on page 560.
 - 36 To learn to enjoy life to the maximum there is no standard way. A good foundation can be found in those books which teach the ability to those which have lost it. Cited on page 562.
 The best experts are those who help others to overcome traumas. PETER A. LEVINE, *Waking the tiger* - ..., ...GEOFF GRAHAM, ...
 A good complement to these texts is the systemic approach, as presented by BERT HELLINGER, *Zweierlei Glück*, Carl Auer Verlag, 1997. Some of his books are also available in english. The author explains how to achieve a life of contentness, living with the highest possible responsibility of one's actions, by reducing entanglements with one's past and with other people. He presents a simple and efficient technique for realizing this disentanglement.
 The next step, namely full mastery in the enjoyment of life, can be copied from any book written by somebody who has achieved mastery in any one topic. The topic itself is not important, only the passion is.

Body ...

Mind ...

Spirit ...

PLATO, *Phaedrus*, A beautiful text ...

A. DE LA GARANDERIE, ... and his other books. The author is expert on teaching and learning, especially on the importance of the evocation, imagination and motivation.

FRANÇOISE DOLTO, ..., and her other books. The author, child psychiatrist, is one of the world experts on the growth of the child; her main theme is that growth is only possible by giving the highest possible responsibility to every child during its evolution.

In the domain of art, many had the passion to achieve full pleasure. A good piece of music, a beautiful painting, an expressive statue or a good movie can show it. On a smaller scale, the art to typeset beautiful books, so different from what many computer programs do by default, the best introduction is by Jan Tschichold (1902–1974), the undisputed master of the field. Among the many books he designed are the beautiful Penguin books of the late 1940s; he also was a type designer, e.g. of the *Sabon* typeface. A beautiful summary of his views is the short but condensed text JAN TSCHICHOLD, *Ausgewählte Aufsätze über Fragen der Gestalt des Buches und der Typographie*, Birkhäuser Verlag, Basel, 1993. An extensive and beautiful textbook on the topic is HANS PETER WILLBERG & FRIEDRICH FORSSMAN, *Lesetypographie*, Verlag Hermann Schmidt, Mainz, 1997.

Many scientists passionately enjoyed their occupation. Any biography of Darwin will purvey his fascination for biology, of Bessel for astronomy, of Einstein for physics and of Pauling for chemistry.

- 37** The group of John Wearden in Manchester has shown by experiments with persons that the accuracy of a few percent is possible for any action of duration between a tenth of a second and a few minutes. See J. MCCRONE, *When a second lasts forever*, *New Scientist* pp. 53–56, 1 November 1997. Cited on page [565](#).
- 38** E.J. ZIMMERMAN, *American Journal of Physics* **30**, 1962, pp. 97–105. Cited on page [566](#).
- 39** PETER D. PESIĆ, *The smallest clock*, *European Journal of Physics* **14**, pp. 90–92, 1993. Cited on page [567](#).
- 40** A pretty example of a quantum mechanical system showing exponential behaviour at all times is given by H. NAKAZATO, M. NAMIKI & S. PASCAZIO, *Exponential behaviour of a quantum system in a macroscopic medium*, *Physical Review Letters* **73**, pp. 1063–1066, 1994. Cited on page [568](#).
- 41** See the delightful book about the topic by PAOLO FACCHI & SAVERIO PASCAZIO, *La regola d'oro di Fermi*, Bibliopolis, 1999. An experiment observing deviations at short times is S.R. WILKINSON, C.F. BHARUCHA, M.C. FISCHER, K.W. MADISON, P.R. MORROW, Q. NIU, B. SUNDARAM & M.G. RAIZEN, *Nature* **387**, p. 575, 1997. Cited on page [568](#).
- 42** R. FULL, *Nature*, **405**, p. 681, ... Cited on page [573](#).
- 43** For good figures of atomic orbitals, see for example the chemistry text by ... Cited on page [573](#).
- 44** For pictures of the orbitals of dangling bonds, see for example F. GIESSIBL & al., *Science* **28**, p. 422, 2000. Cited on page [573](#).
- 45** J.L. COSTA-KRÄMER, N. GARCIA, P. GARCIA-MOLCHALES, P.A. SERENA, *Physical Review B* 1996. Cited on page [574](#).
- 46** The original prediction is in R.B. LAUGHLIN, *Physical Review Letters* **50**, pp. 1395–1398, 1982. The first experimental evidence is by V.J. GOLDMAN & B. SU, *Science* **267**, p. 1010, 1995. The first unambiguous measurements are by R. DE PICCIOTTO & al., *Nature* **389**, pp. 162–164, 1997, and L. SAMINADAYAR, D.C. GLATTLI, Y. JIN & B. ETIENNE, *Physical Review Letters* ... 1997. or [cond-mat/9706307](#). Cited on page [574](#).

- The discovery of the quantum Hall effect was published by K. VON KLITZING & G. DORDA, *Physical Review Letters* **45**, pp. 494–497, 1980.
- The fractional quantum Hall effect was discovered by D.C. TSUI, H.L. STORMER & A.C. GOSSARD, *Physical Review Letters* **48**, pp. 1559–1562, 1982.
- 47** H.B.G. CASIMIR, *On the attraction between two perfectly conducting bodies*, *Proc. Kon. Ned. Acad. Wetensch.* **51**, pp. 793–795, 1948. Cited on page .
- 48** H.B.G. CASIMIR & D. POLDER, *The influence of retardation on the London-Van der Waals forces*, *Physical Review* **73**, pp. 360–372, 1948. Cited on page .
- 49** S.L. BOERSMA, *A maritime analogy of the Casimir effect*, *American Journal of Physics* **64**, pp. 539–541, 1996. Cited on page [579](#).
- 50** A. LARRAZA & B. DENARDO, *An acoustic Casimir effect*, *Physics Letters A* **248**, p. 151¹–155, 1998. Cited on page [580](#).
- 51** M.J. SPARNAAY, *Nature* **180**, p. 334, 1957. M.J. SPARNAAY, *Measurements of attractive forces between flat plates*, *Physica (Utrecht)* **24**, pp. 751–764, 1958. Cited on page [580](#).
- 52** S.K. LAMOREAUX, *Demonstration of the Casimir force in the 0.6 to 6 μm range*, *Physical Review Letters* **78**, pp. 5–8, 1997. U. MOHIDEEN & A. ROY, *Precision Measurement of the Casimir Force from 0.1 to 0.9 μm* , *Physical Review Letters* **81**, pp. 4549–4552, 1998. Cited on page [580](#).
- 53** The effect was discovered by K. SCHARNHORST, *On propagation of light in the vacuum between plates*, *Physics Letters B* **236**, pp. 354–359, 1990. See also G. BARTON, *Faster-than-c light between parallel mirrors: the Scharnhorst effect rederived*, *Physics Letters B* **237**, pp. 559–562, 1990, and P.W. MILONNI & K. SVOZIL, *Impossibility of measuring faster-than-c signalling by the Scharnhorst effect*, *Physics Letters B* **248**, pp. 437–438, 1990. The latter corrects an error in the first paper. Cited on page [580](#).
- 54** M. KARDAR, R. GOLESTANIAN, *The ‘friction’ of the vacuum, and other fluctuation-induced forces*, *Reviews of Modern Physics* **71**, pp. 1233–1245, 1999. Cited on page [581](#).
- 55** G. GOUR & L. SRIRAMKUMAR, *Will small particles exhibit Brownian motion in the quantum vacuum?*, <http://www.lanl.gov/quant/phys/9808032> Cited on page [581](#).
- 56** P.A.M. DIRAC, ..., 1985. This article transcribes a speech by Paul Dirac just before his death. Disturbed by the infinities of quantum electrodynamics, he rejects as wrong the theory which he himself found, even though it correctly describes all experiments. The humility of a great man who is so dismissive of his main and great achievement was impressive when hearing him, and still is impressive when reading the speech. Cited on page [582](#).
- 57** Misleading statements are given in the introduction and in the conclusion of the review by H. PAUL, *Interference between independent photons*, *Review of Modern Physics*, volume 58, pages 209–231; however, in the bulk of the article the author in practice retracts the statement, e.g. on page 221. Cited on page [575](#), [576](#).
- 58** Thomas STOEHLKER & al., *Physical Review Letters* 9 October 2000. Cited on page [583](#).
- 59** M. ROBERTS & al., *Observation of an electric octupole transition in a single ion*, *Physical Review Letters* **78**, pp. 1876–1879, 1997. A lifetime of 3700 days was determined. Cited on page [583](#).
- 60** K. AN, J.J. CHILDS, R.R. DESARI & M.S. FIELD, *Microlaser: a laser with one atom in an optical resonator*, *Physical Review Letters* **73**, pp. 3375–3378, 19 December 1994. Cited on page [575](#).
- 61** See the web site by Tom Hales on www.math.lsa.umich.edu/~hales/countdown. An earlier book on the issue is the delightful text by MAX LEPPMAIER, *Kugelpackungen von Kepler bis heute*, Vieweg Verlag, 1997. Cited on page [584](#).

- 62** For a short overview, also covering binary systems, see C. BECHINGER, H.-H. VON GRÜNBERG & P. LEIDERER, *Entropische Kräfte - warum sich repulsiv wechselwirkende Teilchen anziehen können*, *Physikalische Blätter* **55**, p. 53-56, 1999. Cited on page [584](#).
- 63** HANS-WERNER FINK, *Direct observation of three-body interactions in adsorbed layers: Re on W(111)*, *Physical Review Letters* **52**, pp. 1532-1534, 1984. Cited on page [584](#).
- 64** See for example the textbook by A. PIMPINELLI & J. VILLAIN, *Physics of crystal growth*, Cambridge University Press, 1998. Cited on page [584](#).
- 65** P.G. DE GENNES, *Soft matter*, *Reviews of Modern Physics* **63**, p. 645, 1992. Cited on page [584](#).
- 66** The fluid helium based quantum gyroscope 1: czech group, 2: berkley group, *Nature* 10. April 1997 Cited on page [585](#).
- 67** K. SCHWAB & al., *Nature* **404**, p. 974, 2000. For the optical analog, see reference [20](#). Cited on page [585](#).
- 68** J.P. BRIAND & al., *Production of hollow atoms by the excitation of highly charged ions in interaction with a metallic surface*, *Physical Review Letters* **65**, pp. 159-162, 1990. Cited on page [585](#).
See also C. RHODES, *Hollow atoms*, ..., and ...*Physikalische Blätter* Oktober 1996.
- 69** The present knowledge on how humans move is summarized by ... Cited on page [589](#).
- 70** See e.g. D.A. BRYANT, *Electron acceleration in the aurora*, *Contemporary Physics* **35**, pp. 165-179, 1994. Cited on page [589](#).
- 71** The discharges above clouds are described e.g. by ... Cited on page [589](#).
- 72** See e.g. L.O'C. DRURY, *Acceleration of cosmic rays*, *Contemporary Physics* **35**, pp. 231-242, 1994. Cited on page [589](#).
- 73** About Coulomb explosions, see ... Cited on page [589](#).
- 74** See the text by DIRK KREIMER, ..., 2000. Cited on page [589](#).
- 75** R. COLELLA, A.W. OVERHAUSER & S.A. WERNER, *Observation of gravitationally induced quantum mechanics*, *Physical Review Letters* **34**, pp. 1472-1475, 1975. This experiment is usually called the COW experiment. Cited on page [590](#).
- 76** G.C. GHIRARDI, A. RIMINI & T. WEBER, *Unified dynamics for microscopic and macroscopic systems*, *Physical Review D* **34**, pp. 470-491, 1986. Cited on page [590](#).
- 77** CH.J. BORDÉ & C. LÄMMERZAHN, *Atominterferometrie und Gravitation*, *Physikalische Blätter* **52**, pp. 238-240, 1996. See also A. PETERS, K.Y. CHUNG & S. CHU, *Observation of gravitational acceleration by dropping atoms*, *Nature* **400**, pp. 849-852, 26 August 1999. Cited on page [590](#).
- 78** X. NESVIZHEVSKY & al., *Nature* 17 January 2002. Cited on page [590](#).
- 79** JAKOB BEKENSTEIN, *Black holes and entropy*, *Physical Review D* p. 2333, 1973. Cited on page [592](#).
- 80** This is clearly argued by S. CARLIP, *Black hole entropy from horizon conformal field theory*, *Nuclear Physics B Proceedings Supplement* **88**, pp. 10-16, 2000. Cited on page [592](#).
- 81** PAUL DAVIES, ..., WILLIAM G. UNRUH, *Notes on black hole evaporation*, *Physical Review D* **14**, p. 870-892, 1976. Cited on page [592](#).
- 82** About the possibility to measure Davies-Unruh radiation, see for example the paper <http://arxiv.org:gr-qc/9605032>. Cited on page [592](#).
- 83** W.G. UNRUH, R.M. WALD, ..., *Physical Review D* **25**, pp. 942-958, 1982. Cited on page [593](#).

- 84** For a delightful popular account from a black hole expert, see IGOR NOVIKOV, *Black holes and the universe*, Cambridge University Press 1990. Cited on page [594](#), [597](#).
- 85** The original paper is W.G. UNRUH, *Experimental black hole evaporation?*, Physical Review Letters **46**, pp. 1351–1353, 1981. A good explanation with good literature overview is the one by MATT VISSER, *Acoustical black holes: horizons, ergospheres and Hawking radiation*, <http://xxx.lanl.gov/abs/gr-qc/9712010>. Cited on page [595](#).
- 86** Optical black holes ... Cited on page [595](#).
- 87** T. DAMOUR & R. RUFFINI, Physical Review Letters **35**, p. 463, 1975. Cited on page [595](#).
- 88** These were the Vela satellites; their existence and results were announced officially only in 1974, even though they were working already for many years. Cited on page [595](#).
- 89** The best general introduction into the topic of gamma ray bursts is S. KLOSE, J. GREINER & D. HARTMANN, *Kosmische Gammastrahlenausbrüche – Beobachtungen und Modelle*, Teil I und II, Sterne und Weltraum March and April 2001. Cited on page [595](#), [596](#).
- 90** When the gamma ray burst encounters the matter around the black hole, it is broadened. The larger the amount of matter, the broader the pulse is. See G. PREPARATA, R. RUFFINI & S.-S. XUE, A & A **338**, p. L87, 1998, and R. RUFFINI, J.D. SALMONSON, J.R. WILSON & S.-S. XUE, A & A **350**, pp. 334–343, 1999. For a very personal account by Ruffini on his involvement in gamma ray bursts, see his paper *Black hole formation and gamma ray bursts*, <http://arxiv.org:astro-ph/0001425>. Cited on page [596](#).
- 91** About the membrane description of black holes, see ... Cited on page [597](#).
- 92** Negative heat capacity has also been found in atom clusters and in nuclei. See e.g. X. SCHMIDT & al., Physical Review Letters 12 February 2001. Cited on page [597](#).
- 93** He wrote a series of papers on the topic; a beautiful summary is DON N. PAGE, *How fast does a black hole radiate information?*, International Journal of Modern Physics **3**, pp. 93–106, 1994, based on his earlier papers, such as *Information in black hole radiation*, Physical Review Letters **71**, pp. 3743–3746, 1993, and *Average entropy of a subsystem*, Physical Review Letters **71**, pp. 1291–1294, 1993. The entropy formula of the latter paper, used above, was proven by S.K. FOONG & S. KANNO, *Proof of Page's conjecture on the average entropy of a subsystem*, Physical Review Letters **72**, pp. 1148–1151, 1994. See also his computer preprint at <http://xxx.lanl.gov/abs/hep-th/9305040>. Cited on page [598](#).
- 94** See DON N. PAGE, ..., Cited on page [598](#).
- 95** The author speculates that this version of the coincidences could be original; he has not found it in the literature. Cited on page [591](#).
- 96** STEVEN WEINBERG, *Gravitation and Cosmology*, (Wiley, 1972). See equation 16.4.3 on page 619 and also page 620. Cited on page [591](#).
- 97** It could be that knot theory provides a relation between local knot invariant and a global one. Cited on page [591](#).
- 98** E. JOOS, *Why do we observe a classical space-time?*, Physics Letters A **116**, pp. 6–8, 1986. Cited on page [600](#).
- 99** This point was made repeatedly by STEVEN WEINBERG, namely in ..., Physics Letters **9**, p. 357, 1964, in ..., Physical Review B **135**, p. 1049, 1964, and in .., Physical Review B **138**, p. 988, 1965. Cited on page [600](#).
- 100** An overview on squeezed light is given in ... Cited on page .
- 101** An introduction into the history of the concept of precision is given by N.W. WISE, *The values of precision*, Princeton University Press, 1994. Cited on page .
- 102** E.H. KENNARD, *Zur Quantenmechanik einfacher Bewegungstypen*, Zeitschrift für Physik **44**, pp. 326–352, 1927. The priority of the result is often wrongly attributed to the much later

- paper by H.P. ROBERTSON, *The uncertainty principle*, Physical Review **34**, pp. 163–164, 1929. The complete result is by ERWIN SCHRÖDINGER, *Sitzungsberichte der Preussischen Akademie der Wissenschaften, Physikalisch-Mathematische Klasse Berlin*, p. 296, 1930. Cited on page .
- 103** W. HEISENBERG, *Über den anschaulichen Inhalt der quantentheoretischen Kinematik und Mechanik*, *Zeitschrift für Physik* **43**, pp. 172–198, 1927. Cited on page .
- 104** M.G. RAYMER, *Uncertainty principle for joint measurement of noncommuting variables*, *American Journal of Physics* **62**, pp. 986–993, 1994. Cited on page .
- 105** The question about the origin of blue colour in flowers has been discussed already in the beginning of the twentieth century. A short summary is given by K. YOSHIDA & al., *Cause of blue petal colour*, *Nature* **373**, p. 291, 26 January 1995. Cited on page .
- 106** The main reference on nondemolition measurements is the text by C.M. CAVES & P.D. DRUMOND, *Quantum limits on bosonic communication rates*, *Reviews of Modern Physics* **66**, pp. 481–537, 1994. Cited on page .
- 107** MARK P. SILVERMAN, *And yet it moves: strange systems and subtle questions in physics*, Cambridge University Press, 1993. It is a treasure chest for anybody interested in the details of physics.
The two other books by MARK P. SILVERMAN, *More than one mystery*, Springer 1995, talking about the Aharonov-Bohm effect, about the EPR paradox, and about the Hanbury-Brown-Twiss experiments, and *Waves and grains: reflections on light and learning*, Princeton University Press, 1998, are also collections of interesting thoughts about physics. Cited on page .
- 108** N. ASHCROFT & D. MERMIN, *Solid state physics*, Saunders, 1976, is probably the best as well as the most original and entertaining introduction to the topic available in English language. Cited on page .
- 109** The famous quantum theory book is P.A.M. DIRAC, *Quantum mechanics*, 4th revised edition, Oxford University Press, 1967. Cited on page .



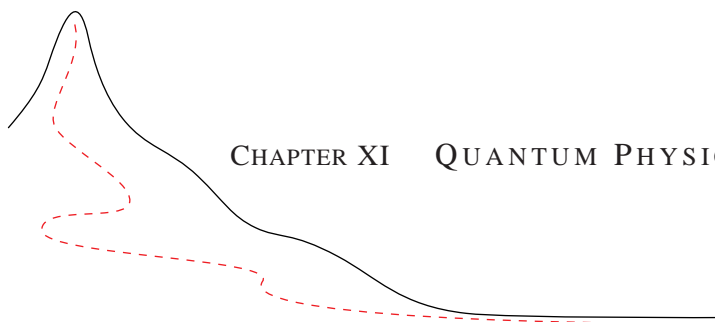

CHAPTER XI QUANTUM PHYSICS IN A NUTSHELL

Achievements in precision

Compared to the classical description of motion, quantum theory is remarkably more complex. The basic idea is simple: in nature there is a minimum change, or a minimum action. The minimum action implies the strange observations made in the microscopic domain, such as wave behaviour of particles, tunnelling, uncertainty relations, randomness in measurements, quantization of angular momentum, pair creation, decay, indistinguishability and particle reactions. The mathematics is often disturbingly involved. Was this part of the walk worth the effort? It was.

Quantum theory improved the accuracy of predictions from the few – if any – digits common in classical mechanics to the full number of digits – sometimes fourteen – one is able to measure today. The limit is *not* given by the theory, it is given by the measurement accuracy. In other words, the agreement is only limited the amount of money the experimenter is willing to spend, Table 46 shows this in more detail.

Table 46 A few comparisons between quantum theory and experiment

Observable	Classical prediction	Prediction of quantum theory ^a	Measurement	Cost ^b , estimated
Simple motion of bodies				
Uncertainty	0	$\Delta x \Delta p \geq \hbar/2$	$(1 \pm 10^{-2}) \hbar/2$	10 k\$
Wavelength of matter beams	none	$\lambda p = 2\pi\hbar$	$(1 \pm 10^{-2}) \hbar$	10 k\$
Tunnelling rate in alpha decay	0	$\tau = \dots$	$(1 \pm 10^{-2}) \tau$	0.5 M\$
Compton wavelength	none	$\lambda_c = h/m_e c$	$(1 \pm 10^{-3}) \lambda$	20 k\$
Pair creation rate	0	20 M\$
Radiative decay time in hydrogen	none	$\tau \sim 1/n^3$...	5 k\$
Smallest angular momentum	0	$\hbar/2$	$(1 \pm \dots) \hbar/2$	1 k\$
Smallest action	0	\hbar	$(1 \pm \dots) \hbar$	10 k\$
Casimir effect	0	ma/A $(\pi^2 \hbar c)/(240r^4)$	$= (1 \pm 10^{-3}) ma$	30 k\$

Observable	Classical prediction	Prediction of quantum theory ^a	Measurement	Cost ^b , estimated
Colours of objects				
Lamb shift	none	$\Delta\lambda$ 1057.86(1)MHz	$= (1 \pm 10^{-6}) \Delta\lambda$	50 k\$
Rydberg constant	none	$R_\infty = m_e c \alpha^2 / 2h$	$(1 \pm 10^{-9}) R_\infty$	50 k\$
Stephan-Boltzmann constant	none	$\sigma = \pi^2 k^4 / 60 \hbar^3 c^2$	$(1 \pm 3 \cdot 10^{-8}) \sigma$	50 k\$
Wien displacement constant	none	$b = \lambda_{\max} T$	$(1 \pm 10^{-5}) b$	100 k\$
Refractive index of ...	none
Photon-photon scattering	0	50 M\$
Particle and interaction properties				
Electron gyromagnetic ratio	1 or 2	2.002 319 304 3(1)	2.002 319 304 3737(82)	30 M\$
Z boson mass	none	$m_Z^2 = m_W^2 (1 + \sin^2 \theta_W)$	$(1 \pm 10^{-3}) m_Z$	100 M\$
proton mass	none	$(1 \pm 5\%) m_p$	$m_p = 1.67 \text{ yg}$	1 M\$
Composite matter properties				
Atom lifetime	$\approx 1 \mu\text{s}$	∞	$> 10^{20} \text{ a}$	10 k\$
Molecular size	none	from QED	within 10^{-3}	20 k\$
Von Klitzing constant	∞	$h/e^2 = \mu_0 c / 2\alpha$	$(1 \pm 10^{-7}) h/e^2$	1 M\$
AC Josephson constant	0	$2e/h$	$(1 \pm 10^{-6}) 2e/h$	5 M\$
Heat capacity of metals at 0 K	0	25 J/K	$< 10^{-3} \text{ J/K}$	10 k\$
Water density	none	...	1000 kg/m ³	10 k\$
Electr. conductivity of ...	none	3 k\$
Proton lifetime	$\approx 1 \mu\text{s}$	∞	$> 10^{35} \text{ a}$	100 M\$

a. These predictions are calculated from the values of Table 47. For more precise values, see Appendix B.

See page 653

See page 811

b. Sometimes the cost for the calculation of the prediction is higher than that its measurement. (Can you spot the examples?) The sum of the two is given.

Challenge 441

One notices that the predicted values are not noticeably different from the measured ones. If we remember that classical physics does not allow to calculate any of these values we get an idea of the progress quantum physics has allowed. But despite this impressive agreement, there still are *unexplained* observations. In fact, these unexplained observations provide the input for the calculations just cited; we list them in detail below, in Table 47.

See page 653

In summary, in the microscopic domain we are left with the impression that quantum theory is in *perfect* correspondence with nature; despite prospects of fame and riches, despite the largest number of researchers ever, no contradiction with observation has been found yet.

Physical results

Deorum offensae diis curae.
Voltaire, *Traité sur la tolérance*.

All of quantum theory can be resumed in two sentences.

- ▷ *In nature, actions smaller than $\frac{\hbar}{2} = 0.53 \cdot 10^{-34}$ Js are not observed.*
- ▷ *All intrinsic properties in nature – with the exception of mass – such as electric charge, spin, parities, etc., appear as integer numbers; in composed systems they either add or multiply.*

The second statement in fact results from the first. It directly leads to the main lesson we learned about motion from quantum mechanics:

If it moves, it is made of particles.

This statement applies to everything, to objects and to images, i.e. to matter and to radiation. Moving stuff is made of *quanta*. Stones, water waves, light, sound waves, earthquakes, gelatine, and everything else we can interact with is made of particles. We started the second part of our mountain ascent with the title question: what is matter and what are interactions? Now we know: they are composites of elementary particles.

See page 827

To be clear, an *elementary particle* is a countable entity, smaller than its own Compton wavelength, described by energy, momentum, and the following *complete* list of intrinsic properties: mass, spin, electric charge, parity, charge parity, colour, isospin, strangeness, charm, topness, beauty, lepton number, baryon number, and *R*-parity.

Challenge 458

Moving entities are made of particles. To see how deep this result is, you can apply it to all those moving entities for which it is usually forgotten, such as ghosts, spirits, angels, nymphs, daemons, devils, gods, goddesses, and souls. You can check yourself what happens when their particle nature is taken into account.

In addition, quantum theory makes quite a number of statements about particle motion:

- There is no rest for microscopic particles. All objects obey the uncertainty principle, which states that

$$\Delta x \Delta p \geq \hbar/2 \quad \text{with} \quad \hbar = 1.1 \cdot 10^{-34} \text{ Js} \quad (516)$$

making rest an impossibility. The state of particles is defined by the same observables as in classical physics, with the difference that observables do not commute. Classical physics appears in the limit that the Planck constant \hbar can effectively be set to zero.

- Quantum theory introduces a probabilistic element into motion. It results from the interactions with the baths in the environment of any system.

- Large number of identical particles with the same momentum behave like waves. The so-called de Broglie wavelength is given by the momentum of a single particle through

$$\lambda = \frac{h}{p} = \frac{2\pi\hbar}{p} \quad (517)$$

both in the case of matter and of radiation. This relation is the origin of the wave behaviour of light. The light particles are called photons; their observation is now standard

practice. All waves interfere, refract and diffract. This applies to electrons, atoms, photons, and molecules. All waves being made of particles, all waves can be seen, touched and moved. Light for example, can be ‘seen’ in photon-photon scattering, can be ‘touched’ using the Compton effect, and it can be ‘moved’ by gravitational bending. Matter particles, such as molecules or atoms, can be seen, e.g. in electron microscopes, as well as touched and moves, e.g. with atomic force microscopes.

- Particles cannot be enclosed. Even though matter is impenetrable, quantum theory shows that tight boxes or insurmountable obstacles do not exist. Waiting long enough always allows to overcome boundaries, since there is a finite probability to overcome any obstacle. This process is called tunnelling when seen from the spatial point of view and is called decay when seen from the temporal point of view. Tunnelling explains the working of television tubes as well as radioactive decay.

- Identical particles are indistinguishable. Radiation is made of bosons, matter of fermions. Under exchange, fermions commute at space-like separations, whereas bosons anticommute. All other properties of quantum particles are the same as for classical particles, namely countability, interaction, mass, charge, angular momentum, energy, momentum, position, as well as impenetrability for matter and penetrability for radiation.

- Particles are described by an angular momentum called spin, specifying their behaviour under rotations. Bosons have integer spin, fermions have half integer spin. An even number of bound fermions or any number of bound bosons yield a composite boson; an odd number of bound fermions or an infinite number of interacting bosons yield a fermion. Solids are impenetrable because of the fermion character of its electrons in the atoms.

- In collisions, particles interact locally, through the exchange of other particles. When matter particles collide, they interact through the exchange of virtual bosons, i.e. off-shell bosons. Motion change is thus due to particle exchange. Exchange bosons of even spin mediate only attractive interactions. Exchange bosons of odd spin mediate repulsive interactions as well.

- Quantum theory defines elementary particles as particles smaller than their own Compton wavelength. Experiments so far failed to detect a non-vanishing size for any elementary particle.

- The properties of collisions imply the existence of antiparticles, as regularly observed in experiments. Elementary fermions, in contrast to many elementary bosons, differ from their antiparticles, and can be created and annihilated only in pairs. Apart from neutrinos, elementary fermions have non-vanishing mass and move slower than light.

- Quantum electrodynamics is the quantum field description of electromagnetism. Like all the other interactions, its Lagrangian is determined by the gauge group, the requirements of space-time (Poincaré) symmetry, permutation symmetry and renormalizability. The latter requirement follows from the continuity of space-time. Through the effects of virtual particles, QED describes decay, pair creation, vacuum energy, Unruh radiation for accelerating observers, the Casimir effect, i.e. the attraction of neutral conducting bodies, and the limit for the localization of particles. In fact, all objects can be localized only within intervals of the Compton wavelength

$$\lambda_C = \frac{h}{mc} = \frac{2\pi\hbar}{mc} \quad . \quad (518)$$

At the latest at these distances we must abandon the classical description and use quantum field theory. Quantum field theory introduces corrections to classical electrodynamics; among others, the nonlinearities thus appearing produce small departures from the superposition principle for electromagnetic fields, resulting in photon-photon scattering.

- Composite matter is separable because of the finite interaction energies of the constituents. Atoms are made of a nucleus made of quarks, and of electrons. They provide an effective minimal length scale to all everyday matter.

- Quantum theory implies, through the appearance of Planck's constant \hbar , that length scales exist in nature. Quantum theory introduces a fundamental jitter in every example of motion. Thus the infinitely small is eliminated. In this way, lower limits to structural dimensions and to many other measurable quantities appear. In particular, quantum theory shows that it is impossible that on the electrons in an atom small creatures live in the same way that humans live on the earth circling the sun. Quantum theory shows the impossibility of Lilliput.

- Clocks and meter bars have finite precision, due to the existence of a smallest action and due to their interactions with baths. On the other hand, all measurement apparatuses must contain baths, since otherwise they would not be able to record results.

- Elementary particles have the same properties as either objects or images, except divisibility. The elementary fermions (objects) are: the six leptons electron, muon, tau, each with its corresponding neutrino, and the six quarks. The elementary bosons (images) are the photon, the eight gluons, and the two weak interaction bosons.

See page 827

- Quantum chromodynamics, the field theory of the strong interactions, explains the masses of mesons and baryons through its descriptions as bound quark states. At fundamental scales, the strong interaction is mediated by the elementary gluons. At femtometer scales, the strong interaction effectively acts through the exchange of spin 0 pions, and is thus strongly attractive.

- The theory of electroweak interactions describes the unification of electromagnetism and weak interactions through the Higgs mechanism and the mixing matrix.

- Since matter is composed of particles, quantum theory provides a complete list of the intrinsic properties which make up what is called an 'object' in everyday life, namely the same which characterize particles. All other properties of objects, such as shape, temperature, (everyday) colour, elasticity, density, magnetism, etc., are merely combinations of the properties from the particle properties. In particular, quantum theory specifies an object, like every system, as a part of nature interacting weakly and incoherently with its environment.

See page 827

- Since quantum theory explains the origin of material properties, it also explains the origin of the properties of life. Quantum theory, especially the study of the electroweak and the strong forces, has allowed to give a common basis of concepts and descriptions to material science, nuclear physics, chemistry, biology, medicine, and to most of astronomy.

For example, the same concepts allow to answer questions such as why water is liquid at room temperature, why copper is red, why the rainbow is coloured, why the sun and the stars continue to shine, why there are about 110 elements, where a tree takes the material to make its wood, and why we are able to move our right hand at our own will.

- Matter objects are permanent because, in contrast to radiation, matter particles can only disappear when their antiparticles are present. It turns out that in our environment antimatter

is almost completely absent, except for the cases of radioactivity and cosmic rays, where it appears in tiny amounts.

- Images, made of radiation, are described by the same properties as matter. Images can only be localized with a precision of the wavelength λ of the radiation producing it.

- Quantum physics leaves no room for cold fusion, astrology, teleportation, telekinesis, supernatural phenomena, multiple universes, or faster than light phenomena, the EPR paradox notwithstanding. Ref. 1

- The particle description of nature, e.g. particle number conservation, follows from the possibility to describe interactions perturbatively. This is possible only at low and medium energies. At extremely high energies the situation changes, and non-perturbative effects come into play.

Is physics magic?

Studying nature is like experiencing magic. Nature often looks different from what it is. During magic we are fooled only if we forget our own limitations. Once we start to see ourselves as part of the game, we start to understand the tricks. That is the fun of it.

- The world looks irreversible, even though it isn't. We never remember the future. We are fooled because we are macroscopic.

- The world looks decoherent, even though it isn't. We are fooled again because we are macroscopic.

- Motion seems to disappear, even though it is eternal. We are fooled again, because our senses cannot experience the microscopic domain.

- The world seems dependent on the choice of the frame of reference, even though it is not. We are fooled because we are used to live on the surface of the earth.

- Objects seem distinguishable, even though they are not. We are fooled because we live at low energies.

- Matter looks continuous, even though it isn't. We are fooled because of the limitations of our senses.

In short, our human condition permanently fools us. Quantum theory answers the title question affirmatively; that is its main attraction.

The dangers of buying a can of beans

The ultimate product warning, which should be printed on its package according to certain well-informed lawyers, gives another summary of our walk so far. It shows in detail how our human condition fools us. Ref. 2

Warning: care should be taken when **looking** at this product:

- It emits heat radiation.
- Bright light has the effect to compress this product.

Warning: care should be taken when **touching** this product:

- Part of it could heat up while another part cools down, causing severe burns.

Warning: care should be taken when **handling** this product:

- This product consists of at least 99,999 999 999 999 % empty space.

- This product contains particles moving with speeds higher than one million kilometres per hour.
- Every kilogram of this product contains the same amount of energy as liberated by about one hundred nuclear bombs.*
- In case this product is brought in contact with antimatter, a catastrophic explosion will occur.
- In case this product is rotated, it will emit gravitational radiation.

Warning: care should be taken when **transporting** this product:

- The force needed depends on its velocity, as does its weight.
- This product will emit additional radiation when accelerated.
- This product attracts, with a force that increases with decreasing distance, every other object around, including its purchaser's kids.

Warning: care should be taken when **storing** this product:

- It is impossible to keep this product in a specific place and at rest at the same time.
- Except when stored underground at a depth of several kilometres, over time cosmic radiation will render this product radioactive.
- This product may disintegrate in the next 10^{35} years.
- It could cool down and lift itself into the air.
- Parts of this product are hidden in other dimensions.
- This product warps space and time in its vicinity, including the storage container.
- Even if stored in a closed container, this product is influenced and influences all other objects in the universe, including your parents in law.
- This product can disappear from its present location and reappear at any random place in the universe, including your neighbour's garage.

Warning: care should be taken when **travelling away from** this product:

- It will arrive at the expiration date before the purchaser does so.

Warning: care should be taken when **using** this product:

- Any use whatsoever will increase the entropy of the universe.
- The constituents of this product are exactly the same as those of any other object in the universe, including those of rotten fish.
- The use could be disturbed by the (possibly) forthcoming collapse of the universe.

The impression of a certain paranoid side to physics is purely coincidental.

The essence of quantum theory

We can summarize quantum physics with a simple statement: *quantum physics is the description of matter and radiation without the concept of infinity.*

Matter and radiation are described by finite quantities. On the other side, this approach does not completely convince; some remainders of infinities had to be retained in our description of nature, namely in the description of space or time, and in topics related to them,

* A standard nuclear warhead has an explosive power of about 0.2 megatons of TNT, i.e. of trinitrotoluene; a megaton is defined as $4.2 \cdot 10^{15}$ J, the energy content of about 47 g of matter. That is less than a handful for most solids or liquids.

This is a section of the freely downloadable e-textbook

Motion Mountain

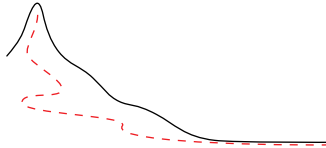

Hiking beyond space and time along the concepts of modern physics

available at
www.motionmountain.org

Copyright © 1997, 1998, 1999, 2000, 2001, 2002 by Christoph Schiller

To the kind reader

In exchange for getting this section for free, I ask you for a short email on some of the following:

- Which page was boring?
- Did you find any mistakes?
- What else were you expecting?
- What was hard to understand?

Of course, any other suggestion is welcome. This section is part of a physics text written over many years. The text lives and grows through the feedback from its readers, who help to improve and to complete it. For a particularly useful contribution (send it in english, italian, dutch, german, spanish, portuguese, or french) you will be mentioned in the foreword of the text, or receive a small reward, or both.

Enjoy!

Christoph Schiller
cs@motionmountain.org

Challenge 475

such as renormalization. We did not manage to eliminate all infinities. We are thus not yet at the end of our quest. Soon we will find out that a completely finite description of all of nature is impossible because neither a completely finite nor a completely infinite description of nature can be accurate.

What is unexplained by quantum mechanics and general relativity?

The material gathered in this second part of our mountain ascent, together with the earlier summary of general relativity, allows us to give a complete answer to this question. Even though the available concepts and theories allow us to describe all observed phenomena connected to motion, there remain some *unexplained* properties of nature. Whenever we ask ‘why?’ and continue doing so after each answer, we arrive at one of the points in Table 47.

Table 47 *Everything* quantum field theory and general relativity do *not* explain; in other words, a list of *the only* experimental data and criteria available for tests of the unified description of motion.

Observed value	Property unexplained so far
Local quantities, from quantum theory	
α_{em}	the low energy value of the electromagnetic coupling constant
α_w	the low energy value of the weak coupling constant
α_s	the low energy value of the strong coupling constant
m_q	the values of the 6 quark masses
m_l	the values of 3 lepton masses (or 6, if neutrinos have masses)
m_W	the values of the independent mass of the W vector boson
θ_W	the value of the Weinberg angle
$\beta_1, \beta_2, \beta_3$	three mixing angles (or 7, if neutrinos have masses)
θ_{CP}	the value of the CP parameter
θ_{st}	the value of the strong topological angle
3	the number of particle generations
3 + 1	the number of space and time dimensions
0.5 nJ/m ³	the value of the observed vacuum energy density or cosmological constant
Global quantities, from general relativity	
$1.2(1) \cdot 10^{26}$ m	the distance of the horizon, i.e. the ‘size’ of the universe (if it makes sense)
(?)	
10^{82} (?)	the number of baryons in the universe, i.e. the average matter density in the universe (if it makes sense)
10^{92} (?)	the initial conditions for more than 10^{92} particle fields in the universe, including those at the origin of galaxies or stars (if they make sense)
Local structures, from quantum theory	
$S(n)$	the origin of particle identity, i.e. of permutation symmetry
Ren. group	the renormalisation properties, i.e. the existence of point particles
SO(3,1)	the origin of Lorentz (or Poincaré) symmetry (i.e. of spin, position, energy, momentum)
C^*	the origin of the algebra of observables
Gauge group	the origin of gauge symmetry (and thus of charge, strangeness, beauty, etc.)

Observed value	Property unexplained so far
in particular, for the standard model:	
U(1)	the origin of the electromagnetic gauge group (i.e. of the quantization of electric charge, as well as the vanishing of magnetic charge)
SU(2)	the origin of weak interaction gauge group
SU(3)	the origin of strong interaction gauge group
Global structures, from general relativity	
maybe $R \times S^3$	the unknown topology of the universe (if it makes sense)
(?)	

The table has several notable aspects. First of all, neither quantum mechanics nor general relativity explain any property unexplained in the other field. The two theories do not help each other; the unexplained parts of both fields simply add up. Secondly, both in quantum theory and in general relativity, motion still remains the change of position with time. In short, in the first two parts of this walk, we did not achieve our goal: we still do not understand motion. Our basic questions remain: What is time and space? What is mass? What is charge and what are the other properties of objects? What are fields? Why are all the electrons the same?

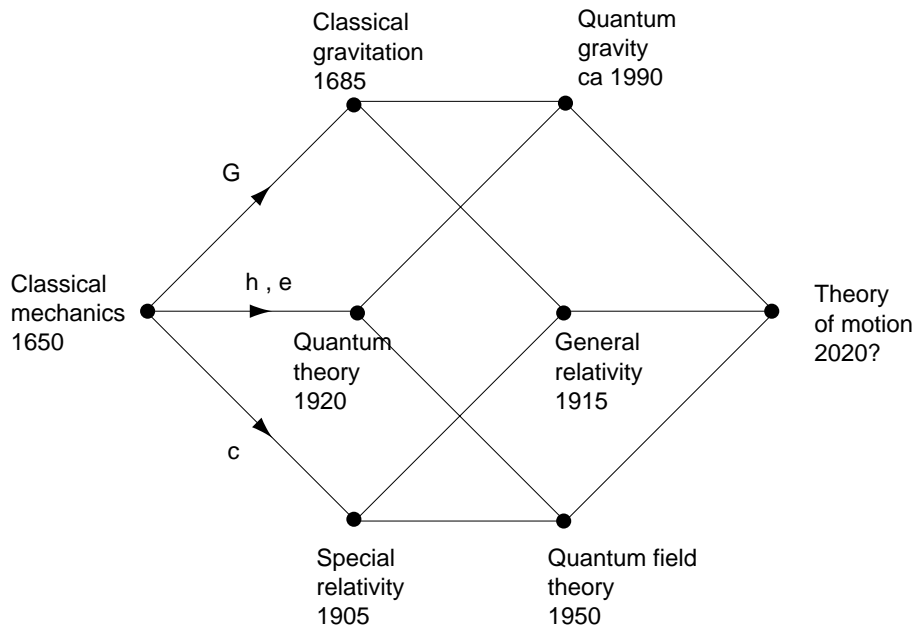

Figure 224 How the description of motion proceeded in the history of physics

We also note that the table lists a lot of extremely *different* concepts. That means that at this point of our walk there is *a lot* we do not understand. Finding the answers will require effort.

On the other hand, the list is also *short*. The description of nature our adventure has produced is concise and precise. No discrepancies with experiments are known. In other words we have a good description of motion *in practice*. Going further is almost unnecessary if

we only want to improve measurement precision. Simplifying the above list is mainly important from the *conceptual* point of view. For this reason, the study of physics at university often stops at this point. However, even though we have *no* known discrepancies with experiments, we are *not* at the top of motion mountain, as Table 47 and Figure 224 show; the last leg forms the third part of our walk.

How to delude oneself to have reached the top of motion mountain

Nowadays is deemed chic to pretend that the adventure is over at this stage.* The reasoning is as follows. If in the previous table on unexplained features of nature we change the values of the constants only ever so slightly, the world would look completely different from what it is.**

Table 48 A tiny selection of the consequences of changing the properties of nature

Observed value	Change	Result
Local quantities, from quantum theory		
α_{em}	smaller:	only short lived, smaller, hotter stars; no sun
	larger:	darker sun, animals die of electromagnetic radiation, too much proton decay, no planets, no stellar explosions, no star formation, no galaxy formation
α_w	+60%:	quarks decay into leptons
	+200%:	proton-proton repulsion makes nuclei impossible
	-50%:	carbon nucleus unstable
	very weak:	no hydrogen, no p-p cycle in stars, no C-N-O cycle
	+2%:	no protons from quarks
α_s	$G_F m_e^2 \neq \sqrt{G m_e^2}$:	either no or only helium in the universe
	much larger:	no stellar explosions, faster stellar burning
	-9%:	no deuteron, stars much less bright
	-1%:	no C resonance, no life
	+3.4%:	diproton stable, faster star burning
θ_w	much larger:	carbon unstable, heavy nuclei unstable, widespread leukaemia
θ_{CP}	different:	...
m_q changes:	different:	...
n-p mass difference	larger:	neutron decays in proton inside nuclei; no elements
	smaller:	free neutron not unstable, all protons into neutrons during big bang; no elements

* Actually this attitude is not new. Only the arguments have changed. Maybe the greatest physicist ever, James Clerk Maxwell, once wrote: ‘..., that, in a few years, all great physical constants will have been approximately estimated, and that the only occupation which will be left to men of science will be to carry these measurements to another place of decimals.’

** Most of the material below is from the mighty book by JOHN D. BARROW & FRANK J. TIPLER, *The Anthropic Cosmological Principle*, Oxford University Press, 1986.

Observed value	Change	Result
m_1 changes:	smaller than m_e :	protons would capture electrons, no hydrogen atoms, star life much shorter
e-p mass ratio	much different:	no molecules
	much smaller:	no solids
m_W different:		
3 generations	6-8:	only helium in nature
	>8:	no asymptotic freedom and confinement
Global quantities, from general relativity		
horizon size	much smaller:	no people
baryon number	very different:	no smoothness
	much higher:	no solar system
Initial condition changes:		
moon mass	smaller:	small earth magnetic field; too much cosmic radiation; widespread child skin cancer
moon mass	larger:	large earth magnetic field; too little cosmic radiation; no evolution into humans
Sun's mass	smaller:	too cold for the evolution of life
Sun's mass	larger:	sun too short lived for the evolution of life
Jupiter mass	smaller:	too many comet impacts on earth; extinction of animal life
Jupiter mass	larger:	too little comet impacts on earth; no moon; no dinosaur extinction
Oort cloud object number	smaller:	no comets; no irregular asteroids; no moon; still dinosaurs
galaxy centre distance	smaller:	irregular planet motion; supernova dangers
initial cosmic speed	+0.1%:	1000 times faster universe expansion
	-0.0001%:	universe recollapses after 10 000 years
vacuum energy density	change by 10^{-55} :	no flatness
3 + 1 dimensions	different:	no atoms, no planetary systems
Local structures, from quantum theory		
permutation symmetry	none:	no matter
Lorentz symmetry	none:	no communication possible
U(1)	different:	no Huygens principle, no way to <i>see</i> anything
SU(2)	different:	no radioactivity, no sun, no life
SU(3)	different:	no stable quarks and nuclei
Global structures, from general relativity		
topology	other:	unknown; possibly correlated gamma ray bursts or star images at the antipodes

Some have summed Table 48 up in a simple sentence: if any parameter is changed, the universe would either have too many or too few black holes.

The table is overwhelming. Obviously, even the tiniest changes in the properties of nature are incompatible with our existence. What does this mean? Answering this question too rapidly is dangerous. Many fall into a common trap, namely to refuse admitting that the unexplained numbers and other properties need to be explained, i.e. deduced from more general principles. It is easier to throw in some irrational belief; three fashionable ones are that the universe is *created* or *designed*, that the universe is *designed for people*, and that the values are random since our universe happens to be *one of many others*.

All these beliefs have in common that they have no factual basis, that they discourage further search and that they sell many books. Physicists call the issue of the first belief *fine tuning*, and usually, but not always, steer clear from the logical errors contained in the so common belief in ‘creation’ discussed earlier on. However, many physicists subscribe to the second belief, namely that the universe is designed for people, calling it the *anthropic principle*, even though we saw that it is indistinguishable both from the simian principle and from the request that statements be based on observations. The third belief, namely *multiple universes*, is a minority view, but also sells well.

See page 462

See page 468

Stopping our mountain ascent with a belief at the present point is not different from doing so directly at the beginning. This used to be the case in societies which lacked the passion for rational investigation, and is still the case in circles which discourage the use of reason among their members. Looking for beliefs instead of looking for answers means to give up the ascent of Motion Mountain while pretending to have reached the top.

That is a pity. In our adventure, accepting the powerful message of Table 48 is one of the most awe-inspiring, touching and motivating moments. There is only one possible implication based on facts: the evidence implies that we are only a *tiny part* of the universe, *linked* with all other aspects of it. Due to our small size and to all the connections with our environment, any imagined tiny change would make us disappear, like a water droplet engulfed by a large wave. Our walk has repeatedly reminded us of this smallness and dependence, and overwhelmingly does so again at this point.

Having faced this conclusion, everybody has to make up his own mind on whether to proceed or not with the adventure. Of course, there is no obligation to do so.

Challenge 492

What awaits us?

The shortness of the list of unexplained aspects of nature means that *no additional experimental data* is available as check of the final description of nature. Everything we need to arrive at the final description of motion will probably be deduced from the experimental data given in this list, and from nothing else. In other words, future experiments will *not* help us – except if they change something in the list, as supersymmetry might do with the gauge groups.

This lack of new experimental data means that to continue the walk is a *conceptual* adventure only. We have to walk into storms raging near the top of motion mountain, keeping our eyes open, without any other guidance except our reason: not an adventure of action, but an adventure of the mind. And an incredible one, as we will soon find out. To provide a feeling of what awaits us, we rephrase a few of the remaining issues in a more challenging way.

What determines *colours*? In other words, what relations of nature fix the famous proton-electron mass ratio of about 1836.2 or the fine structure constant? Like the hero of Douglas Adams, physicists know the answer to the greatest of questions: it is 137.036. But they do not know the question.

What fixes the contents of a *teapot*? It is given by its size to the third power. But why are there only three dimensions? Why is the tea content limited in this way?

Was Democritus *right*? Our adventure has confirmed his statement up to this point; nature is indeed well described by the concepts of particles and of vacuum. At large scales, relativity has added a horizon, and at small scales, quantum theory added vacuum energy and pair creation. Nevertheless, both theories *assume* the existence of particles and assume the existence of space-time, and neither *predicts* them. Even worse, both theories completely fail to predict the existence *any* of the properties either of space-time – such as its dimensionality – or of particles – such as their masses and other quantum numbers. A lot is missing.

Was Democritus *wrong*? One often reads that the standard model has only about twenty unknown parameters; this common mistake negates the remaining 10^{93} initial conditions. To get an idea of the problem, we simply estimate the number N of possible states of all particles in the universe by

$$N = n v d p f \quad (519)$$

where n is the number of particles, v is the number of variables (position, momentum, spin), d is the number of values each of them can take (limited by the maximum of 61 decimal digits), p is the number of space-time points (usually taken to be 10^{183} , assuming that all of the universe is visible) and f is a factor expressing how many of all these initial conditions are actually independent of each other. One thus has

$$N = 10^{92} \cdot 8 \cdot 10^{61} \cdot 10^{183} \cdot f = 10^{336} \cdot f \quad (520)$$

with the small problem that we know nothing whatsoever about f . Its value could be 0, if all data were interdependent, or 1, if none were. Do good arguments for $f = 0$ really exist? In either case we still need to understand how all the particles get their states assigned from this truly enormous range of possibilities.

Were our efforts up to this point *in vain*? Quite at the beginning of our walk we noted that in classical physics, space and time are defined using matter, and matter is defined using space-time. Hundred years of general relativity and of quantum theory, including dozens of geniuses, have not solved this oldest paradox of all. The issue is still open, as you might want to check by yourself.

See page 111

Challenge 509

The answers to these questions define the top of motion mountain. Answering them means to know *everything* about motion. In summary, our quest for the unravelling of the essence of motion gets really interesting only from this point onwards!



References

- 1 An informative account of the world of psychokinesis and the paranormal is given by JAMES RANDI, a professional magician, in *Flim-flam!*, Prometheus Books, Buffalo 1987, as well as in several of his other books. See also the <http://www.randi.org> web site. Cited on page 650.
- 2 This way to look at things goes back to the text by SUSAN HEWITT & EDWARD SUBITZKY, *A call for more scientific truth in product warning labels*, Journal of Irreproducible Results **36**, nr. 1, 1991. Cited on page 650.
- 3 JAMES CLERK MAXWELL, *Scientific papers*, **2**, p. 244, October 1871. Cited on page 655.



Third Part

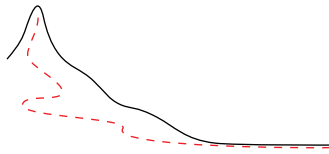

MOTION WITHOUT MOTION

WHAT ARE SPACE, TIME, AND PARTICLES?

Where through the combination of
quantum mechanics and general relativity,
the top of motion mountain is reached,
discovering
that vacuum is indistinguishable from matter,
that space, time and mass are easily confused,
that there is no difference between the very large and the very small,
and that the complete description of motion is possible.
(Ahem – well, wait a few more years for the last line.)



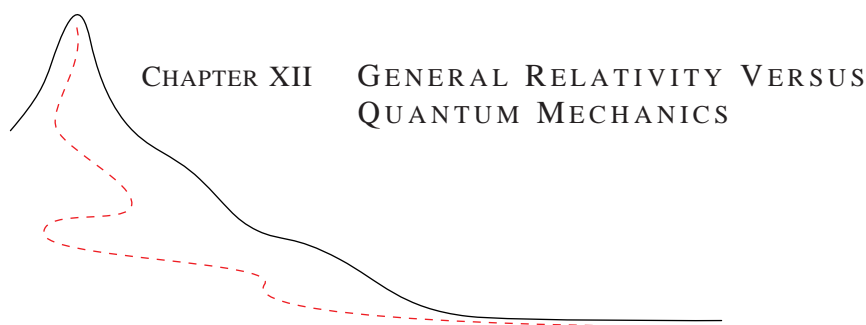

The contradictions

Man muß die Denkgewohnheiten durch Denknöwendigkeiten ersetzen.*
Albert Einstein (Ulm, 1879-Princeton, 1955)

The two stories told in the two parts of the path we followed up to now, namely the one on general relativity and the one on quantum field theory, are both beautiful and successful. We reached a considerable height in our mountain ascent. The precision we achieved in the description of nature is impressive, and we are now able to describe all known examples of motion. So far we encountered no exceptions.

However, the most important aspects of any type of motion, the masses of the involved particles and their coupling strengths, are yet unexplained. Also the origin of the universe's particle number, their initial conditions, and the dimensionality of space-time remains in the dark. Obviously, our adventure has not yet reached its completion.

This last part of our hike will be the most demanding. In the ascent of any high mountain, the head gets dizzy due to lack of oxygen. The finite energies at our disposal require that we leave behind all unnecessary baggage and everything which hinders us. In order to determine what is unnecessary, we need complete focus on what we want to achieve. Our biggest hindrance are all those concepts which are at the origin of the *contradictions* between general relativity and quantum theory. To pinpoint this useless baggage, we first list these contradictions.

In classical physics and in general relativity, the vacuum, or empty space-time, is a region with no mass, no energy and no momentum. If matter or gravitational fields are present, space-time is curved. The best way to measure the mass or energy content of space-time is

Ref. 1 to measure the average curvature of the universe. Cosmology tells us how we can do this; See page 295 measurements yield an average energy density of the 'vacuum' of

$$E/V \approx 1 \text{ nJ/m}^3 \quad . \quad (523)$$

Ref. 2 However, the quantum field theory tells a different story. Following it, vacuum is a region with zero-point fluctuations. The energy content of vacuum is the sum of the zero point energies of all the fields it contains. Indeed, the Casimir effect 'proves' the reality of these zero point energies. Their energy density is given, within one order of magnitude, by See page 579

* 'One needs to exchange thinking habits by thinking necessities.'

$$E/V = \frac{4\pi h}{c^3} \int_0^{v_{\max}} v^3 dv = \frac{\pi h}{c^3} v_{\max}^4 . \quad (524)$$

The approximation is valid for the case that the cutoff frequency v_{\max} is much larger than the rest mass m of the particles corresponding to the field under consideration. Indeed, particle physicists argue that the cutoff energy has to be at least the energy of grand unification, about 10^{16} GeV = 1.6 MJ. That would give a vacuum energy density of

$$E/V \approx 10^{99} \text{ J/m}^3 . \quad (525)$$

That is about 10^{108} times higher than the experimental limit deduced using general relativity. In other words, something is slightly wrong here.

But there are other contradictions between general relativity and quantum theory. Gravity is curved space-time. Extensive research has shown that quantum field theory, the description of electrodynamics and of the nuclear forces, fails for situations with strongly curved space-times. In these cases the concept of particle is not uniquely defined; quantum field theory cannot be extended to consistently include gravity and thus general relativity. Without the concept of particle as a countable entity also the ability to perform perturbation calculations is lost; but these are the only calculations possible in quantum field theory. In short, quantum theory only works because it assumes that gravity does not exist! Indeed, the gravitational constant does not appear in any consistent quantum field theory.

Ref. 3

On the other hand, general relativity neglects the commutation rules between physical quantities discovered by experiments on a microscopic scale. General relativity assumes that position and momentum of material objects can be given the meaning of classical physics. It thus ignores Planck's constant \hbar and only works neglecting quantum theory..

Measurements also lead to problems. In general relativity, like in classical physics, infinite measurement precision is assumed to be possible, e.g. by using finer and finer ruler marks. In contrast, in quantum mechanics the measurement precision is limited. The uncertainty relation gives limits due to the mass M of the apparatus.

See page 438

See page 565

Time shows the contradictions most clearly. Relativity explains that time is what is read from clocks. Quantum theory tells that precise clocks do not exist, especially if the coupling with gravitation is included. What does it mean to wait 10 minutes, if the clock goes into a superposition due to its coupling to space-time geometry?

In addition, quantum theory associates mass to an inverse length, via the Compton wavelength; general relativity associates mass to length, via the Schwarzschild radius.

Similarly, general relativity shows that space and time cannot be distinguished, whereas quantum theory tells that matter does so. Quantum theory is a theory of – admittedly weirdly constructed – local observables. General relativity doesn't have any local observables, as Einstein's hole argument shows.

See page 312

Most dramatically, the contradiction is shown by the failure of general relativity to describe the pair creation of spin 1/2 particles, a typical and essential quantum process. John Wheeler and others have shown that in such a case, the topology of space necessarily has to *change*; in general relativity however, the topology of space is fixed. In short, quantum theory says matter is made of fermions; general relativity cannot incorporate fermions.

Ref. 4, 5

Ref. 6, 7

To sum up, general relativity and quantum theory clash. But as long as a description of nature contains contradictions, it cannot lead to a unified description, to an explanation, or

even to a correct description. In order to proceed, let us take the shortest and fastest path: let us investigate the contradictions in more detail.

31. Does matter differ from vacuum?

Ref. 8 There is a simple way to state the origin of *all* contradictions between general relativity and quantum mechanics. Both theories describe motion with objects made of particles and with space-time made of events. Let us see how these two concepts are defined.

A *particle* – and in general any object – is defined as a conserved entity to which a position can be ascribed and which can move. (The etymology of the term ‘object’ is connected to the latter fact.) In other words, a particle is a small entity with conserved mass, charge etc., which can vary its position with time.

Ref. 9 At the same time, in every physics text *time* is defined with the help of moving objects, usually called ‘clocks’, or with the help of moving particles, such as those emitted by light sources. Similarly, the *length* is defined with objects, be it with an old-fashioned ruler or with help of the motion of light, which in turn is motion of particles.

Modern physics has further sharpened the definitions of particles and space-time. Quantum mechanics assumes space-time given (it is included as a symmetry of the Hamiltonian), and studies the properties and the motion of particles, both for matter and radiation. In general relativity and especially in cosmology, the opposite path is taken: it assumes that the properties of matter and radiation are given, e.g. via their equations of state, and describes in detail the space-time that follows from them, in particular its curvature.

However, one fact remains unchanged throughout all these advances in physics: *the two concepts of particles and of space-time are defined with the help of each other*. To avoid the contradiction between quantum mechanics and general relativity and to eliminate their incompleteness requires the elimination of this circular definition. As argued in the following, this necessitates a radical change in our description of nature, and in particular about the continuity of space-time.

For a long time, the contradictions in the two descriptions of nature were avoided by keeping them separate. One often hears the statement that quantum mechanics is valid at small dimensions and general relativity is valid at large dimensions. But this artificial separation is not justified and obviously prevents the solution of the problem. The situation resembles the well-known drawing by M.C. Escher, where two hands, each holding a pencil, seem to draw each other. Taking one hand as a symbol for space-time, the other as a symbol for particles, and the act of drawing as a symbol for the act of defining, the drawing gives a description of standard twentieth century physics. The apparent contradiction is solved by recognizing that both concepts (both hands) result from a hidden third concept from which the other two originate. In the picture, this third entity is the hand of the painter.

In the case of space-time and matter, the search for the underlying common concept is presently making renewed progress. The required conceptual changes are so dramatic that they should be of interest to anybody who has an interest in physics. The most effective way to study these changes is to focus in detail on that domain where the contradiction between

Ref. 10, 11

Ref. 12, 13



Figure 228 ‘Tekenen’ by M.C. Escher, 1948 – a metaphor for the way in which ‘particles’ and ‘space-time’ are usually defined: each with help of the other

the two standard theories becomes most dramatic, and where both theories are necessary at the same time. That domain is given by a well-known argument.

Planck scales

Both general relativity and quantum mechanics are successful theories for the description of nature. Each of them provides a criterion to determine when classical Galilean physics is not applicable any more. (In the following, we use the terms ‘vacuum’ and ‘empty space-time’ interchangeably.)

General relativity shows that it is necessary to take into account the curvature of space-time whenever we approach an object of mass m to distances of the order of the Schwarzschild radius r_S , given by

$$r_S = 2Gm/c^2 \quad . \quad (526)$$

Indeed, approaching the Schwarzschild radius of an object, the difference between general relativity and the classical $1/r^2$ description of gravity becomes larger and larger. For example, the barely measurable gravitational deflection of light by the sun is due to an approach to $2.4 \cdot 10^5$ times its Schwarzschild radius. In general, we are forced to stay away from objects by an even larger multiple of the Schwarzschild radius, as shown in Table 49. For this reason, general relativity is not necessary in everyday life. (An object smaller than its own Schwarzschild radius is called a *black hole*. Following general relativity, no signals from the inside of the Schwarzschild radius can reach the outside world; hence the name ‘black hole’.)

Ref. 4, 14

Ref. 15

Similarly, quantum mechanics shows that Galilean physics must be abandoned and quantum effects must be taken into account whenever an object is approached to distances of the order of the Compton wavelength λ_C , given by

$$\lambda_C = \frac{\hbar}{m c} \quad . \quad (527)$$

Of course, this length only plays a role if the object itself is smaller than its own Compton wavelength. At these dimensions we get relativistic quantum effects, such as particle-antiparticle creation or annihilation. Table 49 shows that the approach distance d is near or smaller than the Compton wavelength only in the microscopic world, so that such effects are not observed in everyday life. Therefore we do not need quantum field theory to describe common observations.

This is a section of the freely downloadable e-textbook

Motion Mountain

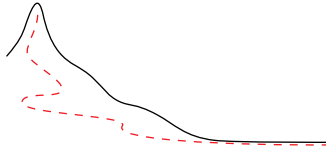

Hiking beyond space and time along the concepts of modern physics

available at
www.motionmountain.org

Copyright © 1997, 1998, 1999, 2000, 2001, 2002 by Christoph Schiller

To the kind reader

In exchange for getting this section for free, I ask you for a short email on some of the following:

- Which page was boring?
- Did you find any mistakes?
- What else were you expecting?
- What was hard to understand?

Of course, any other suggestion is welcome. This section is part of a physics text written over many years. The text lives and grows through the feedback from its readers, who help to improve and to complete it. For a particularly useful contribution (send it in english, italian, dutch, german, spanish, portuguese, or french) you will be mentioned in the foreword of the text, or receive a small reward, or both.

Enjoy!

Christoph Schiller
cs@motionmountain.org

Challenge 594

Object	size: diameter d	mass m	Schwarz- schild radius r_S	ratio d/r_S	Compton wave length λ_C	ratio d/λ_C
galaxy	≈ 1 Zm	$\approx 5 \cdot 10^{40}$ kg	≈ 70 Tm	$\approx 10^7$	$\approx 10^{-83}$ m	$\approx 10^{104}$
neutron star	10 km	$2.8 \cdot 10^{30}$ kg	4.2 km	2.4	' $1.3 \cdot 10^{-73}$ m'	$8.0 \cdot 10^{76}$
sun	1.4 Gm	$2.0 \cdot 10^{30}$ kg	3.0 km	$4.8 \cdot 10^5$	' $1.0 \cdot 10^{-73}$ m'	$8.0 \cdot 10^{81}$
earth	13 Mm	$6.0 \cdot 10^{24}$ kg	8.9 mm	$1.4 \cdot 10^9$	' $5.8 \cdot 10^{-68}$ m'	$2.2 \cdot 10^{74}$
human	1.8 m	75 kg	0.11 ym	$1.6 \cdot 10^{25}$	' $4.7 \cdot 10^{-45}$ m'	$3.8 \cdot 10^{44}$
molecule	10 nm	0.57 zg	' $8.5 \cdot 10^{-52}$ m'	$1.2 \cdot 10^{43}$	$6.2 \cdot 10^{-19}$ m	$1.6 \cdot 10^{10}$
atom (^{12}C)	0.6 nm	20 yg	' $3.0 \cdot 10^{-53}$ m'	$2.0 \cdot 10^{43}$	$1.8 \cdot 10^{-17}$ m	$3.2 \cdot 10^7$
proton p	2 fm	1.7 yg	' $2.5 \cdot 10^{-54}$ m'	$8.0 \cdot 10^{38}$	$2.0 \cdot 10^{-16}$ m	9.6
pion π	2 fm	0.24 yg	' $3.6 \cdot 10^{-55}$ m'	$5.6 \cdot 10^{39}$	$1.5 \cdot 10^{-15}$ m	1.4
up-quark u	< 0.1 fm	0.6 yg	' $9.0 \cdot 10^{-55}$ m'	$< 1.1 \cdot 10^{38}$	$5.5 \cdot 10^{-16}$ m	< 0.18
electron e	< 4 am	$9.1 \cdot 10^{-31}$ kg	' $1.4 \cdot 10^{-57}$ m'	$3.0 \cdot 10^{39}$	$3.8 \cdot 10^{-13}$ m	$< 1.0 \cdot 10^{-5}$
neutrino ν_e	< 4 am	$< 3.0 \cdot 10^{-35}$ kg	' $< 4.5 \cdot 10^{-62}$ m'	n.a.	$> 1.1 \cdot 10^{-8}$ m	$< 3.4 \cdot 10^{-10}$

Table 49 The size, Schwarzschild radius, and Compton wavelength of some objects appearing in nature. A short reminder of the new SI prefixes: f: 10^{-15} , a: 10^{-18} , z: 10^{-21} , y: 10^{-24} , P: 10^{15} , E: 10^{18} , Z: 10^{21} , Y: 10^{24} . Note that the lengths between quotes make no physical sense, as explained in this section.

The *combined* concepts of quantum field theory and general relativity are required in situations in which both conditions are satisfied simultaneously. The necessary approach distance is calculated by setting $r_S = 2\lambda_C$ (the factor 2 is introduced for simplicity). We find that this is the case when lengths or times are (of the order of)

$$\begin{aligned}
 l_{\text{Pl}} &= \sqrt{\hbar G/c^3} = 1.6 \cdot 10^{-35} \text{ m, the Planck length,} \\
 t_{\text{Pl}} &= \sqrt{\hbar G/c^5} = 5.4 \cdot 10^{-44} \text{ s, the Planck time.}
 \end{aligned}
 \tag{528}$$

Whenever we approach objects to these scales, general relativity and quantum mechanics both play a role; at these scales effects of *quantum gravity* appear. The values of the Planck dimensions being extremely small, this level of sophistication is unnecessary in everyday life, in astronomy and even in particle physics.

However, the questions mentioned at the beginning – why do we live in three dimensions or why is the proton 1836.15 times heavier than the electron – require for their answer a precise and complete description of nature. The contradictions between quantum mechanics and general relativity make the search for answers impossible. On the other hand, the unified theory, describing quantum gravity, is not yet finished; however, we can take a few glimpses on its implications already at the present stage.

Note that the Planck scales are one of only two domains of nature where quantum mechanics and general relativity apply at the same time. Planck scales being the most easy to study, they provide the best possible starting point for the following discussion. When Planck discovered them, he was interested in the Planck units mainly as *natural units of*

Ref. 16

measurement, and that is how he called them. However, their importance in nature is much more pervasive, as we will see now.

Farewell to instants of time

Time is composed of time atoms ... which in fact are indivisible.
Moses Maimonides, 12th century.

The appearance of the quantum of action in the description of motion leads to quantum limits to all measurements. These limits have important consequences at Planck dimensions which appear most clearly when we investigate the properties of clocks and meter bars. Is it possible to construct a clock which is able to measure time intervals shorter than the Planck time? Surprisingly, the answer is no, even though in the time–energy uncertainty relation $\Delta E \Delta t \geq \hbar$ it seems that by making ΔE arbitrary large, we can make Δt arbitrary small.

Ref. 17, 18

Any clock is a device with some moving parts. Parts can be mechanical wheels, matter particles in motion, changing electrodynamic fields, i.e. photons, or decaying radioactive particles. For each moving component of a clock, such as the two hands of the dial, the uncertainty principle applies. As discussed most clearly by ... Raymer, the uncertainty relation for two non-commuting variables describes two different, but related situations: it makes a statement about standard *deviations* of *separate* measurements on *many* identical systems, and it describes the measurement *precision* for a *joint* measurement on a *single* system. Throughout this article, only the second viewpoint is used.

Ref. 19, 20

Ref. 21

In any clock, we need to know both the time and the energy of each hand, in order for it to work. Otherwise it would not be a recording device. Put simply, it must be a classical system. We therefore need the joint knowledge of non-commuting variables for each moving component of the clock; we are interested in the component with the largest time uncertainty Δt . It is evident that the smallest time interval δt which can be measured by a clock is always larger than the quantum limit, i.e. larger than the time uncertainty Δt for its moving components. Thus we have

$$\delta t \geq \Delta t \geq \frac{\hbar}{\Delta E} \quad (529)$$

where ΔE is the energy uncertainty of the moving component. This energy uncertainty ΔE is surely smaller than the total energy $E = mc^2$ of the component itself.* Furthermore, any clock provides information; therefore, signals have to be able to leave it. To make this possible, the clock may not be a black hole; its mass m must therefore be smaller than the Schwarzschild mass for its size, i.e. $m \leq c^2 l / G$, where l is the size of the clock (neglecting factors of order unity). Finally, the size l of the clock must be smaller than $c \delta t$ itself, to allow a sensible measurement of the time interval δt , since otherwise different parts of the clock could not work together to produce the same time display.** Putting all these conditions

* Physically, this condition means to be sure that there is only *one* clock; the case $\Delta E > E$ would mean that it is impossible to distinguish between a single clock, or a clock plus a pair of clock-anticlock created from the vacuum, or a component plus two such pairs, etc.

** It is amusing to explore how a clock larger than $c \delta t$ stops working, due to the loss of rigidity of its components.

together one after the other, we get

$$\delta t \geq \frac{\hbar G}{c^5 \delta t} \quad , \quad (530)$$

or

$$\delta t \geq \sqrt{\frac{\hbar G}{c^5}} = t_{\text{Pl}} \quad . \quad (531)$$

In summary, from three simple properties of every clock, namely that we have only one of them, that we can read its dial, and that it gives sensible readouts, we get the general conclusion that *clocks cannot measure time intervals shorter than the Planck time*.

Note that this argument is independent of the nature of the clock mechanism. Whether the clock is powered by gravitational, electrical, plain mechanical or even nuclear means, the relations still apply.*

The same result can also be found in other ways. For example, any clock small enough to measure small time intervals necessarily has a certain energy uncertainty due to the uncertainty relation. At the same time, following general relativity, any energy density induces a deformation of space-time, and signals from that region arrive with a certain delay due to that deformation. The energy uncertainty of the source leads to a uncertainty in deformation and thus of the delay. The expression from general relativity for the deformation of the time part of the line element due to a mass m is $\delta t = mG/lc^3$. Using Einstein's mass energy relation we get that an energy spread ΔE produces an uncertainty Δt in the delay

$$\Delta t = \frac{\Delta E G}{lc^5} \quad . \quad (532)$$

It determines the precision of the clock. Now the energy uncertainty of the clock is bound by the uncertainty relation for time and energy $\Delta E \geq \hbar/\Delta t$, again involving the precision of the clock. Putting this together, we again find the relation $\delta t \geq t_{\text{Pl}}$ for the minimum measurable time. We are forced to conclude that *in nature there is a minimum time interval*. In other words, *at Planck scales the term 'instant of time' has no theoretical nor experimental backing*. It therefore makes no sense to use it.

Farewell to points in space

In a similar way we can deduce that it is impossible to make a meter bar or any other length measuring device able to measure lengths shorter than the Planck length. Obviously, we can deduce this already from $l_{\text{Pl}} = ct_{\text{Pl}}$. But a separate proof is also possible.

The straightforward way to measure the distance between two points is to put an object at rest at each position. In other words, joint measurements of position and momentum are

* Note that gravitation is essential here. The present argument differs from the well-known study on the limitations of clocks due to their mass and their measuring time published by Salecker and Wigner, and summarized in pedagogical form by Zimmerman. Here, both quantum mechanics as well as gravity are included, and therefore a different, lower, and much more fundamental limit is found. Note also that the discovery of black hole radiation does not change the argument; black hole radiation notwithstanding, measurement devices cannot be inside black holes.

necessary for every length measurement. Now the minimal length δl that can be measured is surely larger than the position uncertainty of the two objects. From the uncertainty principle it is known that each object's position cannot be determined with a precision Δl smaller than that given by the uncertainty relation $\Delta l \Delta p = \hbar$, where Δp is the momentum uncertainty. Requiring to have only one object at each end, i.e. avoiding pair production from the vacuum, means $\Delta p < mc$; together this gives

$$\delta l \geq \Delta l \geq \frac{\hbar}{mc} . \quad (533)$$

Furthermore, the measurement cannot be performed if signals cannot leave the objects; thus they may not be black holes. Therefore their masses must be so small that their Schwarzschild radius $r_S = 2Gm/c^2$ is smaller than the distance δl separating them. Dropping again the factor of 2, we get

$$\delta l \geq \sqrt{\frac{\hbar G}{c^3}} = l_{\text{Pl}} . \quad (534)$$

Another way to deduce this limit reverses the role of general relativity and quantum theory. To measure the distance between two objects, we have to localize the first object with respect to the other within a certain interval Δx . The corresponding energy uncertainty obeys $\Delta E = c(c^2 m^2 + (\Delta p)^2)^{1/2} \geq c\hbar/\Delta x$. But general relativity shows that a small volume filled with energy changes the curvature, and thus changes the metric of the surrounding space. For the resulting distance change Δl , compared to empty space, we find the expression $\Delta l \approx G\Delta E/c^4$. In short, if we localize a first particle in space with a precision Δx , the distance to a second particle is known only with precision Δl . The minimum length δl that can be measured is obviously larger than each of the quantities; inserting the expression for ΔE , we find again that the minimum measurable length δl is given by the Planck length.

Ref. 4, 14
Ref. 26, 27, 28
Ref. 29, 30, 31

As a remark, the Planck length being the shortest possible length, it follows that there can be no observations of quantum mechanical effects for situations in which the corresponding de Broglie or Compton wavelength would be smaller. In usual proton-proton collisions we observe both pair production and interference effects. But the Planck limit implies that in everyday, macroscopic situations, such as car-car collisions, embryo-antiembryo pair production or quantum interference effects cannot be observed.

In summary, from two simple properties common to all length measuring devices, namely that they can be counted and that they can be read out, we arrive at the conclusion that *lengths smaller than the Planck length cannot be found in measurements*. Whatever the method used, be it a meter bar or time of flight measurement, we cannot overcome this fundamental limit. It follows that *the concept of 'point in space' has no experimental backing*. In the same way, the term 'event', being a combination of 'point in space' and 'instant of time', also loses its meaningfulness for the description of nature.

Ref. 32 These results are often summarized in the so-called generalized uncertainty principle

$$\Delta p \Delta x \geq \hbar/2 + f \frac{G}{c^3} (\Delta p)^2 \quad (535)$$

or

$$\Delta p \Delta x \geq \hbar/2 + f \frac{l_{\text{Pl}}^2}{\hbar} (\Delta p)^2 \quad (536)$$

where f is a numerical factor of order unity. A similar expression holds for the time-energy uncertainty relation. The first term on the right hand side is the usual quantum mechanical uncertainty. The second term, negligible at everyday life energies, plays a role only near Planck energies. It is due to the changes in space-time induced by gravity at these high energies. You easily deduce from (535) that the generalized principle automatically implies that Δx can never be smaller than $f^{1/2}l_{\text{Pl}}$.

Challenge 611

The generalized uncertainty principle is derived in exactly the same way in which Heisenberg derived the original uncertainty principle $\Delta p \Delta x \geq \hbar/2$, namely by studying the deflection of light by the object under a microscope. A careful recalculation of the process, not disregarding gravity, yields equation (535). For this reason, *all* approaches which try to unify quantum mechanics and gravity must yield this relation; indeed it appears in canonical quantum gravity, in superstring theory, and in the quantum group approach.

Ref. 32
 Ref. 33
 Ref. 34
 Ref. 35, 36, 37

We remember that quantum mechanics starts when realizing that the classical concept of action makes no sense below the value of \hbar ; similarly, unified theories start when realizing that the classical concepts of time and length make no sense below Planck values. However, the usual description of space-time does contain such small values; the usual description claims the existence of intervals smaller than the smallest measurable one. *Therefore the continuum description of space-time has to be abolished in favour of a more appropriate one.*

A new uncertainty relation appearing at Planck scales shows that continuity cannot be a good description of space-time. Inserting $c\Delta p \geq \Delta E \geq \hbar/\Delta t$ into equation (535) we get

Ref. 38

$$\Delta x \Delta t \geq \hbar G/c^4 = t_{\text{Pl}} l_{\text{Pl}}, \quad (537)$$

which of course has no counterpart in standard quantum mechanics. It shows that space-time events do not exist. A final way to convince oneself that points have no meaning is that a point is an entity with vanishing volume; however, the minimum volume possible in nature is the Planck volume $V_{\text{Pl}} = l_{\text{Pl}}^3$.

Space-time points are idealizations of events. But this idealization is incorrect. The use of the concept of ‘point’ is similar to the use of the concept of ‘aether’ one century ago: it is impossible to detect, and it is useful to describe observations only until the way to describe nature without it has been found.

In other words, the Planck units do not only provide natural units, they also provide – within a factor of order one – the *limit* values of space and time intervals.

Farewell to the space-time manifold

The consequences of the Planck limits for time and space measurements can be taken much further. It is commonplace to say that given any two points in space or any two instants of time, there is always a third in between. Physicists sloppily call this property continuity, mathematicians call it denseness. However, at Planck dimensions this property cannot hold, since intervals smaller than the Planck time can never be found. Thus points and instants are not dense, and *between two points there is not always a third*. But this means that *space and time are not continuous*. Of course, at large scales they are – approximately – continuous, in the same way that a piece of rubber or a liquid seems continuous at everyday dimensions, but is not at small scales.

All paradoxes resulting from the infinite divisibility of space and time, such as Zeno's argument or the Banach-Tarski paradox, are avoided. We can now dismiss the paradoxes straight-away because of their incorrect premises on the nature of space and time.

But let us go on. Special relativity, quantum mechanics and general relativity all rely on the idea that time can be defined for all points of a given reference frame. However, two clocks at a distance l cannot be synchronized with arbitrary precision. Since the distance between two clocks cannot be measured with an error smaller than the Planck length l_{Pl} , and transmission of signals is necessary for synchronization, it is not possible to synchronize two clocks with a better precision than the time $l_{\text{Pl}}/c = t_{\text{Pl}}$, the Planck time. Due to this impossibility to synchronize clocks precisely, the idea of a single time coordinate for a whole reference frame is only approximate, and cannot be maintained in a precise description of nature.

Ref. 39 Moreover, since the time difference between events can only be measured within a Planck time, for two events distant in time by this order of magnitude, it is not possible to say with complete certainty which of the two *precedes* the other! This is an important result. If events cannot be ordered, the concept of time, which is introduced in physics to describe sequences, cannot be defined at all at Planck scales. In other words, after dropping the idea of a common time coordinate for a complete frame of reference, we are forced to drop the idea of time at a single 'point' as well. Therefore, the concept of 'proper time' loses its sense at Planck scales.

It is straightforward to use the same arguments to show that length measurements do not allow us to speak of continuous space, but only of *approximately* continuous space. Due to the lack of measurement precision at Planck scales, the concepts of spatial order, translation invariance, isotropy of the vacuum, and global coordinate systems lack experimental backing.

But there is more to come. The very existence of a minimum length contradicts special relativity, where it is shown lengths undergo Lorentz contraction when switching frame of reference. A minimum length thus cannot exist in special relativity. Therefore, *space-time is neither Lorentz invariant, nor diffeomorphism invariant, nor dilatation invariant at Planck dimensions*. All symmetries at the basis of special and general relativity are thus only approximately valid at Planck scales.

Ref. 26, 40 Due to the imprecision of measurement, most familiar concepts used to describe spatial relations become useless. For example, the concept of *metric* loses its usefulness at Planck scales. Since distances cannot be measured with precision, the metric cannot be determined. We deduce that it is impossible to say precisely whether space is flat or curved. In other words, *the impossibility to measure lengths exactly is equivalent to fluctuations of the curvature, and thus equivalent to fluctuations of gravity*.

In addition, even the number of space dimensions makes no sense at Planck scales. Let us remind ourselves how to determine this number experimentally. One possible way is to determine how many points we can choose in space such that all their distances are equal. If we can find at most n such points, the space has $n - 1$ dimensions. We recognize that without reliable length measurements there is no way to determine reliably the number of dimensions of a space at Planck scales with this method.

Another way to check for three dimensions is to make a knot in a shoe string and glue the ends together: since it stays knotted we know that space has three dimensions, because it

is a mathematical theorem that in spaces with more or less than three dimensions, knots do not exist. Again, at Planck dimensions the measurement errors do not allow to say whether a string is knotted or not, because measurement limits at crossings make it impossible to say which strand lies above the other; in short, we cannot check whether space has three dimensions or not at Planck dimensions.

Many other methods to determine space dimensionality.* All these methods start from the definition of the concept of dimensionality, which is based on a precise definition of the concept of neighbourhood. But at Planck scales, as just mentioned, length measurements do not allow us to say whether a given point is inside or outside a given volume. In short, whatever method we use, the lack of reliable length measurements means that *at Planck scales, the dimensionality of physical space is not defined*. It should therefore not come as a surprise that when we *approach* those scales, we could get a scale-dependent answer, different from three.

The reason for the troubles with space-time become most evident when we remember the well-known definition by Euclid: ‘A point is that which has no part.’ As Euclid clearly understood, a physical point, and here the stress is on *physical*, cannot be defined *without* some measurement method. A physical point is an idealization of position, and as such includes measurement right from the start. In mathematics however, Euclid’s definition is rejected; mathematical points do not need metrics for their definition. Mathematical points are elements of a set, usually called a space. In mathematics, a measurable or a metric space is a set of points equipped *afterwards* with a measure or a metric. Mathematical points do not need a metric for their definition; they are basic entities. In contrast to the mathematical situation, the case of physical space-time, the concepts of measure and of metric are *more fundamental* than that of a point. The difficulties distinguishing physical and mathematical space and points arise from the failure to distinguish a mathematical metric from a physical length measurement.**

Ref. 41

Perhaps the most beautiful way to make this point is the Banach-Tarski theorem. It clearly shows the limits of the concept of volume. The theorem states that a sphere made of *mathematical points* can be cut into six pieces in such a way that two sets of three pieces can be put together to form two spheres, each of the *same volume* as the original one. However, the necessary cuts are ‘infinitely’ curved and complex. For physical matter such as gold, unfortunately – or fortunately – the existence of a minimum length, namely the atomic distance,

Ref. 42

* For example, we can determine the dimension using the topological properties of space only. If we draw a covering of a topological space with open sets, there are always points which are elements of several sets of the covering. Call p the maximal number of sets of which a point can be an element in a given covering. Determine this number for all coverings. The minimum value of p , minus one, gives the dimension of the space.

In fact, if physical space is not a manifold, the various methods could give different answers for the dimensionality. For linear spaces without norm, the number of dimensions cannot even be defined at all.

** Where does the incorrect idea of continuous space-time have its roots? In everyday life, as well as in physics, space-time is introduced to describe observations. Space-time is a bookkeeping device. Its properties are extracted from the properties of observables. Since observables can be added and multiplied, we extrapolate that they can take continuous values. This extrapolation implies that length and time intervals can take continuous, and in particular arbitrary small values. From this consequence we get the possibility to define points and sets of points. A special fields of mathematics, topology, shows how to start from a set of points to construct, with help of neighbourhood relations and separation properties, first a *topological space*. Then, with help of a metric, a *metric space* can be built, and finally, with the appropriate compactness and connectedness relations, a *manifold*, characterized by its dimension, metric and curvature.

makes it impossible to perform such a cut. For vacuum, the puzzle reappears: for example, the energy of zero-point fluctuations is given by a density times the volume; following the Banach-Tarski theorem, the zero point energy content of a single sphere should be equal to the zero point energy of two similar spheres each of the same volume as the original one. The paradox is solved by the Planck length, as it provides a fundamental length scale also for the vacuum, thus making infinitely complex cuts impossible. Therefore, *the concept of volume is only well defined at Planck scales if a minimum length is introduced.*

To sum up, *physical space-time cannot be a set of mathematical points.* But the surprises are not finished. At Planck dimensions, since both temporal and spatial order break down, there is no way to say if the distance between two near enough space-time regions is space-like or time-like. Measurement limits make it impossible to distinguish the two cases. *At Planck scales, time and space cannot be distinguished from each other.*

In summary, space-time at Planck scales is not continuous, not ordered, not endowed with a metric, not four-dimensional, not made of points. If we compare this with the definition of the term manifold, * not one of its defining properties is fulfilled. We arrive at the conclusion that *the concept of a space-time manifold has no backing at Planck scales.* But this idea is slow to disappear, because *even though both general relativity and quantum mechanics use continuous space-time, the combination of both theories does not.*

There is nothing in the world but matter in motion,
and matter in motion cannot move otherwise than in space and time.
Lenin

Farewell to observables and measurements

To complete this state of affairs, if space and time are not continuous, all quantities defined as derivatives versus space or time are not defined precisely. Velocity, acceleration, momentum, energy, etc., are only well-defined under the assumption of continuous space and time. The important tool of the evolution equation, based on derivatives, such as the Schrödinger or the Dirac equation, cannot be used any more. Concepts such as ‘derivative’, ‘divergence-free’, ‘source free’, etc., lose their meaning at Planck scales.

In fact, all physical observables are defined using length and time measurements. Any list of physical units shows that each of them is a product of powers of length, time (and mass) units. (Even though in the SI system electrical quantities have a separate base quantity, the ampere, the argument still holds; the ampere is itself defined by measuring a force, which is measured using the three base units length, time, and mass.) Since time and length are not continuous, observables themselves are not defined, as their value is not fixed. This means that *at Planck scales, observables are not to be described by real numbers.*

In addition, if time and space are not continuous, the usual expression for an observable field A , namely $A(t, x)$, does not make sense: we have to find a more appropriate description. *Physical fields cannot exist at Planck scales.*

The consequences for quantum mechanics are severe. It makes no sense to define multiplication of observables by continuous, i.e. real numbers, but only by discrete steps. Among

* A manifold is what *locally* looks like an Euclidean space. The exact definition can be found in Appendix D.

others, this means that observables do not form a linear algebra. We recognize that due to measurement errors, we cannot prove that observables do form such an algebra. This means that *observables are not described by operators at Planck scales*. But quantum mechanics is based on the superposition principle: without it, it all comes crumbling down. Moreover, the most important observables are the gauge potentials. Since they do not form an algebra, *gauge symmetry is not valid at Planck scales*. Even innocuous looking expressions such as $[x_i, x_j] = 0$ for $x_i \neq x_j$, which are at the basis of quantum field theory, become meaningless at Planck scales. Even worse, also the superposition principle cannot be backed up by experiment at those scales. Even the famous Wheeler-DeWitt equation, often assumed to describe quantum gravity, cannot be valid at those scales.

Similarly, permutation symmetry is based on the premise that we can distinguish two points by their coordinates, and then exchange particles at those two locations. As just seen, this is not possible if the distance between the two particles is small; we conclude that *permutation symmetry has no experimental backing at Planck scales*.

Even discrete symmetries, like charge conjugation, space inversion, and time reversal cannot be correct in that domain, because there is no way to verify them exactly by measurement. *CPT symmetry is not valid at Planck scales*.

Finally, also renormalization symmetry is destroyed.

All these results are consistent: if there are no symmetries at Planck scales, there also are no observables, since physical observables are representations of symmetry groups. In fact, the limits on time and length measurements imply that *the concept of measurement has no significance at Planck scales*.

Can space-time be a lattice? Can it be dual?

Discretization of space-time has been studied already in the 1940s. More recently, the idea that space-time is described as a lattice has also been explored most notably by David Finkelstein and by Gerard 't Hooft. It is generally agreed that in order to get an isotropic and homogeneous situation for large, everyday scales, the lattice cannot be periodic, but must be random. Moreover any fixed lattice violates the result that there are no lengths smaller than the Planck length: due to the Lorentz contraction, any moving observer would find lattice distances smaller than the Planck value. Worse, the lattice idea conflicts with general relativity, in particular with the diffeomorphism invariance of the vacuum. Finally, where would a particle be *during* the jump from one lattice point to the next? In summary, *space-time cannot be a lattice*. The idea of space-time as a lattice is based on the idea that if a minimum distance exists, then all distances are a multiple of this minimum. However, as we will see, there is no evidence at all for this conclusion, and actually there is quite some evidence for the contrary.

If space-time is not a set of points or events, it must be something else. Three hints already appear at this stage. The first necessary step to improve the description of motion starts with the recognition that to abandon 'points' means to abandon the *local* description of physics. Both quantum mechanics and general relativity assume that the phrase 'observable at a point' had a precise meaning. Due to the impossibility of describing space as a manifold, this expression is no longer useful. The unification of general relativity and quantum physics forces a *non-local* description of nature at Planck scales.

Ref. 43

Ref. 44

Ref. 45

Ref. 46

Ref. 47

The existence of a minimal length implies that there is no way to physically distinguish locations that are spaced by even smaller distances. We are tempted to conclude that therefore *any* pair of locations cannot be distinguished, even if they are one meter apart, since on any path joining two points, any two nearby locations cannot be distinguished. We notice that this situation is similar to the question about the size of a cloud or of an atom. Measuring water density or electron density, we find non-vanishing values at any distance from the centre of the cloud; however, an effective size of the cloud can still be defined, because it is very improbable to see effects of a cloud's or of an atom's presence at distances much larger than this effective size. Similarly, we guess that two space-time points at macroscopic distance from each other can be distinguished because the probability that they will be confused drops rapidly with increasing distance. In short, we are thus led to a *probabilistic* description of space-time. It becomes a macroscopic observable, a *statistical*, or *thermodynamic limit* of some microscopic entities.

We note that a fluctuating structure for space-time would also avoid the problems of fixed structures with Lorentz invariance. This property is of course compatible with a statistical description. In summary, the experimental observations of special relativity, i.e. Lorentz invariance, isotropy, and homogeneity, together with that of a minimum distance, point towards a *fluctuating* description of space-time. In the mean time, research efforts in quantum gravity, superstring theory and quantum groups have confirmed independently from each other that a probabilistic and non-local description of space-time at Planck dimensions, resolves the contradictions between general relativity and quantum theory. To clarify the issue, we have to turn to the concept of particle.

Farewell to particles

In every example of motion, some object is involved. One of the important discoveries of the natural sciences was that all objects are composed of small constituents, called *elementary particles*. Quantum theory shows that all composite, non-elementary objects have a finite, non-vanishing size. This property allows us to determine whether a particle is elementary or not. If it behaves like a point particle, it is elementary. At present, only the leptons (electron, muon, tau and the neutrinos), the quarks, and the radiation quanta of the electromagnetic, the weak and the strong nuclear interaction (the photon, the W and Z bosons, the gluons) have been found to be elementary. A few more elementary particles are predicted by various refinements of the standard model. Protons, atoms, molecules, cheese, people, galaxies, etc., are all composite, as shown in Table 49. Elementary particles are characterized by their vanishing size, their spin, and their mass.

Even though the definition of 'elementary' as point particle is all we need in the following argument, it is not complete, because it seems to leave open the possibility that future experiments show that electrons or quarks are not elementary. This is not so! In fact any particle smaller than its own Compton wavelength is elementary. If it were composite, there would be a lighter component inside it; this lighter particle would have a larger Compton wavelength than the composite particle. This is impossible, since the size of a composite particle must be larger than the Compton wavelength of its components. (The possibility that all components be heavier than the composite, which would avoid this argument, does not lead to satisfying physical properties; for example, it leads to intrinsically unstable components.)

See page 827

See page 674

The *size* of an object, such as the one given in Table 49, is defined as the length at which differences from point-like behaviour is observed. This is the way in which, using alpha particle scattering, the radius of the atomic nucleus was determined for the first time in Rutherford's experiment. In other words, the size d of an object is determined by measuring how it scatters a beam of probe particles. Also in daily life, when we look at objects, we make use of scattered photons. In general, in order to make use of scattering, the effective wavelength $\lambda = \hbar/mv$ of the probe must be smaller than the object size d to be determined. We thus need $d > \lambda = \hbar/(mv) \geq \hbar/(mc)$. In addition, in order to make a scattering experiment possible, the object must not be a black hole, since then it would simply swallow the approaching particle. This means that its mass m must be smaller than that of a black hole of its size; in other words, from equation (526) we must have $m < dc^2/G$. Combining it with the previous condition we get

$$d > \sqrt{\frac{\hbar G}{c^3}} = l_{\text{Pl}} \quad . \quad (538)$$

In other words, there is no way to observe that an object is smaller than the Planck length. *There is thus no way in principle to deduce from observations that a particle is point-like.* In fact, it makes no sense to use the term 'point particle' at all! Of course, the existence of a minimal length both for empty space and for objects are related. If the term 'point of space' is meaningless, then the term 'point particle' is so as well. As in the case of time, the lower limit on length results from the combination of quantum mechanics and general relativity.*

The size d of any elementary particle is by definition surely smaller than its own Compton wavelength $\hbar/(mc)$. Moreover, a particle's size is always larger than the Planck length: $d > l_{\text{Pl}}$. Combining these two requirements and eliminating the size d we get a condition for the mass m of any elementary particle, namely

$$m < \frac{\hbar}{cl_{\text{Pl}}} = \sqrt{\frac{\hbar c}{G}} = m_{\text{Pl}} = 2.2 \cdot 10^{-8} \text{ kg} = 1.2 \cdot 10^{19} \text{ GeV}/c^2 \quad (539)$$

This limit, the so-called *Planck mass*, corresponds roughly to the mass of a ten days old human embryo, or equivalently, to that of a small flea. In short, *the mass of any elementary particle must be smaller than the Planck mass.* This fact is already mentioned as 'well-known' by Andrei Sakharov in 1968; he explains that these hypothetical particles are sometimes called 'maximons'. And indeed, the known elementary particles all have masses well below the Planck mass. (Actually, the question why their masses are so incredibly much smaller than the Planck mass is one of the main questions of high energy physics. We will come back to it.)

Ref. 48

There are many other ways to arrive at this mass limit. For example, in order to measure mass by scattering – and that is the only way for very small objects – the Compton wavelength of the scatterer must be larger than the Schwarzschild radius; otherwise the probe would be swallowed. Inserting the definition of the two quantities and neglecting the factor 2, we get again the limit $m < m_{\text{Pl}}$. (In fact it is a general property of descriptions of nature that a minimum space-time interval leads to an upper limit for elementary particle masses.)

Ref. 49

* Obviously, the minimal size of a particle has nothing to do with the impossibility, quantum theory, to localize a particle to within better than its Compton wavelength.

The importance of the Planck mass will become clear shortly.

Another property connected with the size of a particle is its electric dipole moment, which describes the deviation of its charge distribution from spherical shape. The standard model of elementary particles gives as *upper* limit for the electron dipole moment d_e a value of

$$|d_e| < 10^{-39} \text{ m e} \quad , \quad (540)$$

where e is the charge of the electron. This value is ten thousand times smaller than $l_{\text{Pl}} e$. Since that the Planck length is the smallest possible length, we follow that either charge can be distributed in space, or the estimate is wrong, or the standard model is wrong. Several of these can also be wrong at the same time; only future will tell.

There are other strange consequences for particles. In quantum field theory, the difference between a virtual and a real particle is that a real particle is on shell, obeying $E^2 = m^2 c^4 + p^2 c^2$, whereas a virtual particle is off shell, obeying $E^2 \neq m^2 c^4 + p^2 c^2$. Due to the fundamental limits of measurement precision, *at Planck scales we cannot determine whether a particle is real or virtual.*

But that is not all. Antimatter can be described as matter moving backwards in time. Since the difference between backwards and forwards cannot be determined at Planck scales, *matter and antimatter cannot be distinguished at Planck scales.*

Particles are also characterized by their spin. Spin describes two properties of a particle: its behaviour under rotations (and if the particle is charged, the behaviour in magnetic fields) and its behaviour under particle exchange. The wave function of spin 1 particles remains invariant under rotation of 2π , whereas that of spin 1/2 particles changes sign. Similarly, the combined wave function of two spin 1 particles does not change sign under exchange of particles, whereas for two spin 1/2 particles it does.

We see directly that both transformations are impossible to study at Planck scales. Given the limit on position measurements, the position of a rotation axis cannot be well defined, and rotations become impossible to distinguish from translations. Similarly, position imprecision makes the determination of precise separate positions for exchange experiments impossible. In short, *spin cannot be defined at Planck scales, and fermions cannot distinguished from bosons, or, differently phrased, matter cannot be distinguished from radiation at Planck scales.* We can thus easily imagine that supersymmetry, a unifying symmetry between bosons and fermions, somehow becomes natural at Planck dimensions.

But let us now move to the main property of elementary particles.

Farewell to mass

The Planck mass divided by the Planck volume, i.e. the Planck density, is given by

$$\rho_{\text{Pl}} = \frac{c^5}{G^2 \hbar} = 5.2 \cdot 10^{96} \text{ kg/m}^3 \quad (541)$$

and is a useful concept in the following. If we want to measure the (gravitational) mass M enclosed in a sphere of size R and thus (roughly) of volume R^3 , one way to do this is to put a test particle in orbit around it at that same distance R . The universal ‘law’ of gravity then gives for the mass M the expression $M = Rv^2/G$, where v is the speed of the orbiting test particle. From $v < c$, we thus deduce that $M < c^2 R/G$; since the minimum value for R

Challenge 628

is the Planck distance, we get (neglecting again factors of order unity) a limit for the mass density, namely

$$\rho < \rho_{\text{Pl}} \quad . \quad (542)$$

In other words, *the Planck density is the maximum possible value for mass density*. Unsurprisingly, a volume of Planck dimensions cannot contain a mass larger than the Planck mass.

Interesting things happen when we start to determine the error ΔM of a mass measurement in a Planck volume. Let us return to the mass measurement by an orbiting probe. From the relation $GM = rv^2$ we deduce by differentiation that $G\Delta M = v^2\Delta r + 2vr\Delta v > 2vr\Delta v = 2GM\Delta v/v$. For the error Δv in the velocity measurement we have the uncertainty relation $\Delta v \geq \hbar/(m\Delta r) + \hbar/(MR) \geq \hbar/(MR)$. Inserting this in the previous inequality, and forgetting again the factor of 2, we get that the mass measurement error ΔM of a mass M enclosed in a volume of size R follows

$$\Delta M \geq \frac{\hbar}{cR} \quad . \quad (543)$$

Note that for everyday situations, this error is extremely small, and other errors, such as the technical limits of the balance, are much larger.

As a check of this result, we take another situation. We also use relativistic expressions, in order to show that the result does not depend on the details of the situation or the approximations. Imagine having a mass M in a box of size R and weighing the box. (It is supposed that either the box is massless, or that its mass is subtracted by the scale.) The mass error is given by $\Delta M = \Delta E/c^2$, where ΔE is due to the uncertainty in kinetic energy of the mass inside the box. Using the expression $E^2 = m^2c^4 + p^2c^2$ we get that $\Delta M \geq \Delta p/c$, which again reduces to equation (543). Now that we are sure of the result, let us continue.

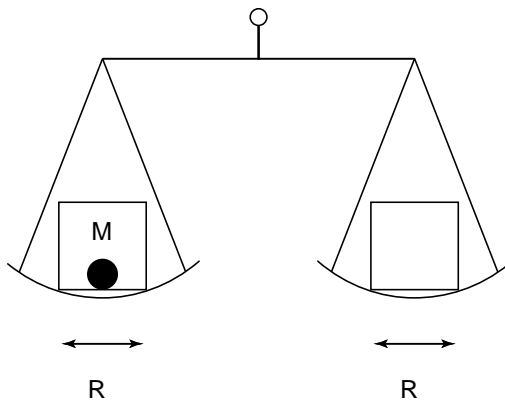

Figure 229 A *Gedankenexperiment* showing that at Planck scales, matter and vacuum cannot be distinguished

Note that even a repeated or a continuous measurement would not resolve the situation: the balance would only randomly change inclination, staying horizontal on average.

The argument can be rephrased as follows. The largest mass we can put in a box of size R is a black hole with a Schwarzschild radius of the same value; the smallest mass present

From equation (543) we deduce that for a box of Planck dimensions, the mass measurement error is given by the Planck mass. But from above we also know that the mass which can be put inside such a box is itself not larger than the Planck mass. Therefore, for a box of Planck dimensions, the mass measurement error is larger (or at best equal) to the mass contained in it: $\Delta M \geq M_{\text{Pl}}$. In other words, if we build a balance with two boxes of Planck size, one empty and the other full, as shown in the figure, nature cannot decide which way the balance should hang!

in such a box – corresponding to what we call vacuum – is due to the uncertainty relation and is given by that mass whose Compton wavelength matches the size of the box. In other words, inside any box of size R we have a mass m whose limits are given by:

$$\text{(full box)} \frac{c^2 R}{G} > m > \frac{\hbar}{cR} \text{(empty box)} \quad . \quad (544)$$

We see directly that for sizes R of the order of the Planck scale, the two limits coincide; in other words, we cannot distinguish a full from an empty box.

To be sure of this strange result, we check whether it also appears if instead of measuring the gravitational mass, as done just now, we measure the inertial mass. The inertial mass for a small object is determined by touching it, i.e. physically speaking, by performing a scattering experiment. To determine the inertial mass inside a region of size R , a probe must have a wavelength smaller than R , and thus a correspondingly high energy. A high energy means that the probe also attracts the particle through gravity. (We thus find the intermediate result that *at Planck scales, inertial and gravitational mass cannot be distinguished*. Even the balance experiment shown in the figure makes this point: at Planck scales, the two effects of mass are always inextricably linked.) Now, in any scattering experiment, e.g. in a Compton-type experiment, the mass measurement is performed by measuring the wavelength change $\delta\lambda$ of the probe before and after the scattering experiment. The mass uncertainty is given by

$$\frac{\Delta M}{M} = \frac{\Delta\delta\lambda}{\delta\lambda} \quad . \quad (545)$$

In order to determine the mass in a Planck volume, the probe has to have a wavelength of the Planck length. But we know from above that there always is a minimal wavelength uncertainty, given by the Planck length l_{Pl} . In other words, for a Planck volume the mass error is always as large as the Planck mass itself: $\Delta M \geq M_{\text{Pl}}$. Again, this limit is a direct consequence of the limit on length and space measurements.

But this result has an astonishing consequence. In these examples, the measurement error is independent of the mass of the scatterer, i.e. independent of whether we start with a situation in which there is a particle in the original volume, or whether there is none. We thus find that in a volume of Planck size, it is impossible to say if there is something or not when probing it with a beam!

In short, all arguments lead to the same conclusion: *vacuum, i.e. empty space-time, cannot be distinguished from matter at Planck scales*. Another, often used way to express this state of affairs is to say that when a particle of Planck energy travels through space it will be scattered by the fluctuations of space-time itself, making it thus impossible to say whether it was scattered by empty space-time or by matter. These surprising results rely on a simple fact: whatever definition of mass we use, it is always measured via combined length and time measurements. (This is even the case for normal weight scales: mass is measured by the displacement of some part of the machine.) The error in these measurements makes it *impossible to distinguish vacuum from matter*.

To put it another way, if we measure the mass of a piece of vacuum of size R , the result is always at least \hbar/cR ; there is no possible way to find a perfect vacuum in an experiment. On the other hand, if we measure the mass of a particle, we find that the result is size dependent;

at Planck dimensions it approaches the Planck mass for every type of particle, be it matter or radiation.

Using another image, when two particles are approached to lengths of the order of the Planck length, the uncertainty in the length measurements makes it impossible to say whether there is something or nothing between the two objects. In short, *matter and vacuum get mixed-up at Planck dimensions*. This is an important result: since both mass and empty space-time can be mixed-up, we have confirmed that they are made of the same ‘fabric’, as suggested above. This approach is now commonplace in all attempts to find a unified description of nature.

This approach is corroborated by the attempts of quantum mechanics in highly curved space-time, where a clear distinction between the vacuum and particles is not possible. This is already shown by the discovery of Unruh radiation. Any accelerated observer and any observer in a gravitational field detects particles hitting him, even if he is in vacuum. The effect shows that for curved space-time the idea of vacuum as a particle-free space does not work. Since at Planck scales it is impossible to say whether space is flat or not, it again follows that it is impossible to say whether it contains particles or not.

Ref. 51

Curiosities and challenges

These strange results imply many others; here is a selection.

- We now have a new answer to the old question: why is there anything instead of nothing? Well, there is *no difference* between anything and nothing.

- We now can honestly say about ourselves: we are made of nothing.
- If vacuum and matter or radiation cannot be distinguished, it is incorrect to claim that the universe appeared from nothing. The impossibility of distinction thus makes creation a logical impossibility. Creation is not a description of reality; it is exposed as a lack of imagination.

- The usual concepts of matter and of radiation are not applicable at Planck dimensions. Usually, it is assumed that matter and radiation are made of interacting elementary particles. The concept of an elementary particle is that of an entity which is countable, point-like, real and not virtual, with a definite mass, a definite spin, distinct from its antiparticle, and most of all, distinct from vacuum, which is assumed to have zero mass. All these properties are found to be incorrect at Planck scales. *At Planck dimensions, it does not make sense to use the concepts of ‘mass’, ‘vacuum’, ‘elementary particle’, ‘radiation’, and ‘matter’.*

- The Planck energy is rather large. Imagine that we want to impart electrons this amount of energy using a particle accelerator. How large would that accelerator be?

Challenge 645

On the other side, in everyday life, the Planck energy is rather small. Measured in litres of gasoline, how much fuel does it correspond to?

Challenge 662

- Do the large measurement errors allow to claim that mass can be negative at Planck energy?

Challenge 679

- Quantum mechanics alone gives, via the Heisenberg uncertainty relation, a lower limit on the spread of measurements, but strangely enough not on their precision, i.e. not on the number of significant digits. Jauch gives the example that atomic lattice constants are known much more precisely than the position uncertainty of single atoms inside the crystal. Despite claims to the contrary, can you show why this cannot be the case for space and time?

Ref. 52

Ref. 36

Challenge 696

▪ Of course, the idea that vacuum is not empty is not new. Already Aristotle argued for a filled vacuum, even though he used incorrect arguments, seen from today's perspective. In the fourteenth century the discussion on whether empty space was composed of indivisible entities was rather common, but died down again later.

Ref. 54 ▪ Special relativity implies that no length or energy can be invariant. Since we came to the conclusion that the Planck energy and the Planck length are invariant, there must be deviations of Lorentz invariance at high energy. Can you imagine how they could look like?

Challenge 713 In what experiment could they be measured?

Ref. 25 ▪ One way to generalize the results presented here is to assume that at Planck energy, nature is *event symmetric*, i.e. that nature is symmetric under exchange of any two events. This idea, developed by Phil Gibbs, provides an additional formulation of the strange behaviour of nature at extreme scales.

See page 324 ▪ Due to a minimum length in nature, naked singularities do not exist. The issue becomes uninteresting, thus ending decades of speculation.

▪ Since mass density and thus energy density is limited, we know that the number of degrees of freedom of any object of finite volume is *finite*. This means among others that perfect baths do not exist. Baths play an important role in thermodynamics (which is thus found to be only an approximation) and also in recording and measuring devices: when a device measures, it switches from a neutral state to a state in which it shows the result of the measurement. In order to avoid that the device returns to the neutral state, it must be coupled to a bath. Without a bath, a reliable measuring device cannot be made. In short, perfect clocks and length measuring devices do not exist because nature puts a limit on their storage ability. More about this shortly.

Ref. 53

See page 34 ▪ If vacuum and matter cannot be distinguished, we cannot distinguish objects and environment. However, this was one the starting points of our walk. Some interesting adventures are thus awaiting us!

▪ We had seen earlier that characterizing nature as made of particles and vacuum creates problems when interactions are included, since interactions on one hand are the difference between the parts and the whole, and on the other hand, as quantum theory says, interactions are exchanges of particles. This connection can be used to show that either vacuum and particles are not everything nature is made of, or that something is counted double. Since matter and space-time are made of the same 'stuff,' both paradoxes are solved.

See page 456

Challenge 730 ▪ Is there a smallest possible momentum? And a smallest momentum error?

▪ There is a maximal acceleration in nature. Can you deduce the value of this so-called Planck acceleration?

Challenge 747

▪ Given that time becomes an approximation at Planck scales, can we still say whether nature is deterministic? Let us go back to the beginning. We can define time, because in nature change is not random, but gradual. What is the situation now that we know that time is only approximate? Is non-gradual change possible? In other words, are surprises possible?

To say that time is not defined at Planck scales, and that therefore determinism is an undefinable concept is correct, but not a satisfying answer. What happens at daily life scales?

The first answer is that at our scales, the probability for surprises is so small, that the world indeed is effectively deterministic. The second answer is that nature is not deterministic, but that the difference is not measurable, since every measurement and observation,

by definition, *implies* a deterministic world. The lack of surprises would be due to the limitations of our human nature, more precisely to the limitations of our senses and brain. The third answer is that the lack of surprises is only apparent, and that we do not grasp them yet.

Can you imagine another possibility? To be honest, there is no answer possible at this point; we will need to keep the alternatives in mind. We have to continue searching. But at every step we are taking, we have to carefully ponder what we are doing.

Challenge 764

- If matter and vacuum cannot be distinguished, matter and vacuum each have the properties of the other. For example, space-time being an extended entity, matter and radiation is so as well. Even more so, space-time being an entity which reaches the borders of the system under scrutiny, particles do so as well. This is the first hint for the extension of matter; in the following, we will examine this argument with more detail.

- Vacuum has zero mass density at large scales, but Planck mass density at Planck scales. Cosmological measurements show that the cosmos is flat or almost flat on large scales, i.e. that its energy density is quite low. On the other hand, quantum field theory maintains that the vacuum has a high energy density (or mass density) on small scales. Since mass is scale dependent, both viewpoints are right, providing a hint to the solution of what is usually called the cosmological constant problem. The contradiction is only apparent; more about this issue later on.

Ref. 6

- When *can* matter and vacuum be distinguished? At what energy?

Challenge 781

- If matter and vacuum cannot be distinguished, a lack of information follows, which in turn produces an intrinsic basic entropy associated with any part of the universe. We will come back to this topic shortly, in the discussion of black hole entropy.

- Can we distinguish between liquids and gases by looking at a single atom? No, only by looking at many. In the same way, we cannot distinguish between matter and vacuum by looking at one point, but only by looking at many. We must always *average*. But even averaging is not completely successful. Distinguishing matter from vacuum is like distinguishing clouds from the clear sky; like clouds, also matter has no defined boundary.

- In our exploration we found that there is no argument showing that space and time are continuous or made of points, and that in contrast, the combination of relativity and quantum theory makes this impossible. In order to proceed in our mountain ascent, we need to leave behind us the usual concept of space-time. *At Planck dimensions, the concepts of 'space-time points' or 'mass points' are not applicable to the description of nature.*

The baggage left behind

In this rapid walk, we have destroyed all the experimental pillars of quantum theory: the superposition principle, space-time symmetry, gauge symmetry, renormalization symmetry, and permutation symmetry. We also have destroyed the foundations of general relativity, namely the existence of the space-time manifold, the field concept, the particle concept, and the concept of mass. It was even shown that matter and space-time cannot be distinguished. It seems that we have lost every concept used for the description of motion, and thus made its description impossible. We naturally ask whether we can save the situation.

First of all, since matter is not distinguishable from vacuum, and since this is correct for all types of particles, be they matter or radiation, we have an argument showing that the quest for unification in the description of elementary particles is correct and necessary.

Moreover, since the concepts ‘mass’, ‘time’, and ‘space’ cannot be distinguished from each other, we also know that a new, *single* entity is necessary to define both particles and space-time. To find out more about this new entity, three approaches are being pursued at the end of the twentieth century. The first, quantum gravity, especially the one using the loop representation and Ashtekar’s new variables, starts by generalizing *space-time symmetry*.
 Ref. 10 The second, string theory, starts by generalizing *gauge symmetries* and interactions, and the
 Ref. 11 third, the algebraic quantum group approach, looks for generalized *permutation symmetries*.
 Ref. 12 We will describe them in more detail shortly.

Before we go on however, we should check what we said so far.

Some experimental predictions

There is a race both in experimental and in theoretical physics going on at present: which will be the first experiment that will detect quantum gravity effects, i.e. effects sensitive to the Planck energy?*

A good candidate is the measurement of light speed at different frequencies from far away light flashes. There are flashes in nature, called gamma ray bursts, which have an extremely broad spectrum, from 100 GeV down to visible light of about 1 eV. These flashes often originate at cosmological distances d . From the difference in arrival time Δt for the two frequencies we can define a characteristic energy by setting

$$E_{\text{char}} = \frac{\hbar(\omega_1 - \omega_2)d}{c\Delta t} . \quad (546)$$

Ref. 55 This energy value is $8 \cdot 10^{16}$ GeV for the best measurement to date. The value is not far from the Planck energy, even more so when the missing factors of order unity are included. It is expected that the Planck scale will be reached in a few years, so that tests will become possible on whether the quantum nature of space-time influences the dispersion of light signals. Planck scale effects should produce a minimum dispersion, different from zero.
 Ref. 56, 57 This effect would allow to confirm that Lorentz symmetry is not valid at Planck scales.

Ref. 60, 57 Another candidate is the direct detection of distance fluctuations between bodies. Gravitational wave detectors are sensitive to extremely small noise signals in length measurements. There should be a noise signal due to the distance fluctuations induced near Planck energies. There is hope that the sensitivity to noise of the detectors will reach the required levels. The noise induced by quantum gravity effects should also lead to quantum decoherence and vacuum fluctuations.
 Ref. 58

A third candidate is the detection of effects signalling the loss of CPT symmetry at high energies. Especially in the case of the decay of certain elementary particles, such as neutral kaons, the experimental measurement precision is approaching the detection of Planck scale effects.
 Ref. 57

Ref. 61 A fourth candidate is the possibility that quantum gravity effects might change the threshold energy at which certain particle reactions become possible. It might be that extremely high energy photons or cosmic rays allow to prove that Lorentz invariance is indeed broken near the Planck scale.

* As more candidates appear, they will be added to this section.

It has also been predicted that quantum gravity effects will induce a gravitational Stark effect and a gravitational Lamb shift in atomic transitions.

Ref. 58

A few candidates for quantum gravity effects have also been predicted by the author. To get an overview, we summarize and clarify the results found so far. * Special relativity starts with the discovery that observable speeds are limited by the speed of light c . Quantum theory starts with the result that observable actions are limited by $\hbar/2$. Gravitation shows that for every system with length L and mass M , the observable ratio L/M is limited by the constant $4G/c^2$. Combining these results, we deduced that all physical observables are *bound*, namely by what are usually called the Planck values, though modified by a factor of square root of 2 (or several of them) to compensate the numerical factors from the previous sentence lost over time.

We need to exchange \hbar by $\hbar/2$ and G by $4G$ in all the defining expressions of Planck quantities, in order to find the corresponding measurement limits. In particular, the limit for lengths and times is $\sqrt{2}$ times the Planck value, and the limit for energy is the Planck value divided by $\sqrt{8}$. ** Interestingly, the existence of bounds on all observables allows to deduce several experimentally testable predictions for the unification of quantum theory and general relativity. These predictions do not depend on the detailed final theory.

However, we need to correct the argument just presented. The argument is only half the story, because so far, we cheated. The (corrected) Planck values do not seem to be the actual limits to measurements. The actual measurement limits are stricter still.

First of all, for any measurement, we need certain fundamental conditions to be realized. Take the length measurement of an object. We need to be able to distinguish between matter and radiation, as the object to be measured is made of matter, and radiation is the measurement tool which is used to read off distances from the ruler. For a measurement process, we need an interaction, which implies the use of radiation. Note that even the use of particle scattering to determine lengths does not invalidate this general requirement.

Also for the measurement of wavelengths we need to distinguish matter and radiation, as matter is necessary to compare two wavelengths. In fact, all length measurements whatsoever require the distinction between matter and radiation. *** But this distinction is impossible at the energy of grand unification, in which the electroweak and the strong nuclear interactions are unified. Above this energy, particles of matter and of radiation cannot be distinguished from each other.

Ref. 59

If all matter and radiation particles were the same, mass cannot be defined. Similarly, spin cannot be defined. If all particles were the same, neither charge nor the other quantum numbers can be defined. To sum up, no measurement can be performed at energies at or above the GUT unification energy.

In other words, the particle concept (and thus the matter concept) does not run into trouble at the Planck scale, it does so already earlier, at the unification scale. Only below the unification scale our standard particle and space-time concepts apply. *Only below the unification scale, particles and vacuum can effectively be distinguished.*

* This subsection, in contrast to the ones so far, is speculative; it was added in February 2001.

** The entropy of a black hole is thus given by the ratio between its horizon and *half* the minimal area. Of course, a detailed investigation also shows that the Planck mass (divided by $\sqrt{8}$) is a limit for elementary particles from *below*, and for black holes from *above*. For everyday systems, there is no limit.

*** To speak in modern high energy concepts, all measurements require broken supersymmetry.

As a result, the smallest length in nature is $\sqrt{2}$ times the Planck length reduced by the ratio between the maximal energy $E_{\text{Pl}}/\sqrt{8}$ and the unification energy E_{GUT} . Following present Ref. 62 estimates, $E_{\text{GUT}} = 10^{16}$ GeV, implying that

$$L_{\text{min}} = \sqrt{2} l_{\text{Pl}} \frac{E_{\text{Pl}}}{\sqrt{8} E_{\text{GUT}}} \approx 10^{-32} \text{ m} \approx 800 l_{\text{Pl}} \quad . \quad (547)$$

It is unlikely that measurements at these dimensions will ever be possible. Anyway, the smallest *measurable* length is quite a bit larger than the Planck scale of nature discussed above. The reason is that the Planck scale is that length for which particles and vacuum cannot be distinguished, whereas the minimal measurable length is the distance at which particles of matter and radiation cannot be distinguished. This happens at lower energy. We thus have to correct our previous statement: *the minimum measurable length cannot be smaller than L_{min} .*

The experimentally determined factor of about 800 is one of the great riddles of physics. It is the high energy translation of the quest to understand why the electromagnetic coupling constant is about 1/137, or simpler, why all things have the colours they have. Only the final theory of motion will provide the answer.

In particular, the minimum length puts a bound on the electric dipole moment d of elementary particles, i.e. on any particles without constituents. We get the limit

$$d > d_{\text{min}} = e L_{\text{min}} = 10^{-32} \text{ m } e = 1.5 \cdot 10^{-51} \text{ Cm} \quad . \quad (548)$$

See page 685 Not only is this result in contradiction with the prediction (540) of the standard model; Ref. 63, 50 more interestingly, it is in the reach of future experiments. This improved limit might be the simplest possible measurement of yet unpredicted quantum gravity effects. Measuring the dipole moment could be a way to determine the unification energy (the factor 800) independently of high energy physics experiments, and possibly to higher precision.

Interestingly, the bound on the measurability of observables also puts a bound on the measurement *precision* for each observable. This bound is of no importance in everyday life, but it is important at high energy. What is the precision with which a coupling constant can be measured? It is sufficient to study the electromagnetic coupling constant as an example. This constant α , also called the fine structure constant, is related to the charge by

$$q = \sqrt{4\pi\epsilon_0 \hbar c \alpha} \quad (549)$$

Now, any electrical charge itself is defined and measured by comparing, in an electrical field, the acceleration the charged object is subjected to with the acceleration of some unit charge. In other words, we have

$$\frac{q}{q_{\text{unit}}} = \frac{ma}{m_{\text{unit}} a_{\text{unit}}} \quad . \quad (550)$$

Therefore any error in mass and acceleration measurements implies errors in charge and coupling constant measurements.

We found in the part on quantum theory that the electromagnetic, the weak, and the strong interactions are characterized by coupling constants whose inverse depends linearly on the

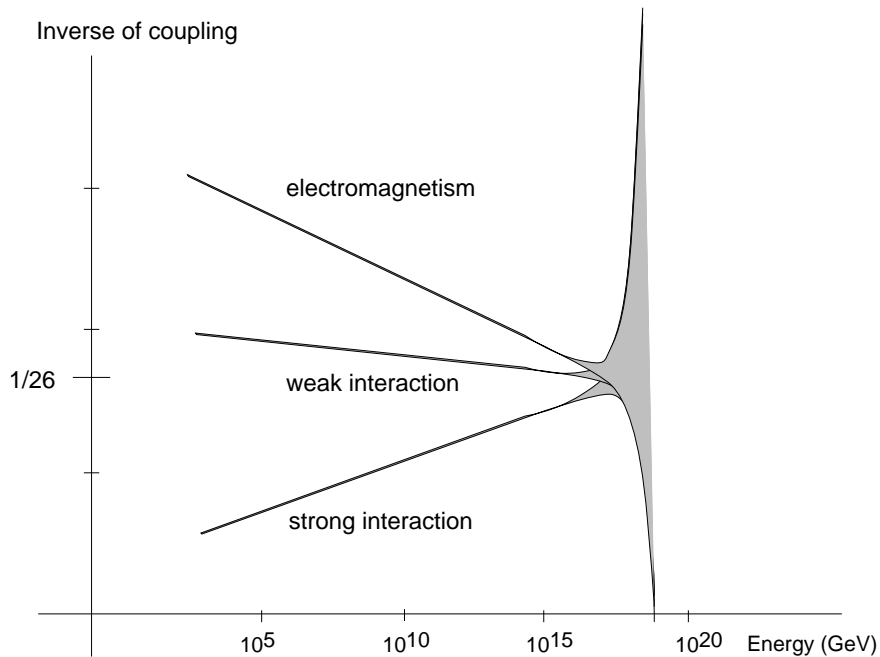

Figure 230 Coupling constants and their spread running with energy

Ref. 62 logarithm of the energy. It is usually assumed that these three lines meet at the already mentioned unification energy. Measurements put the unification coupling value at about $1/26$.

We know from the above discussions that the minimal measurement error for any energy measurement at high energies is given by the ratio between the energy to be measured and the limit energy. Inserting this into the graph of the running coupling constants, we get the result shown in Figure 230. The search for consequences of this *fan-out effect* is delightful. One way to put the result is to say that coupling constants are by definition affected with an error. But all measurement devices, be they clocks, meter bars, scales or something else, use electromagnetic effects at energies of around 1 eV. This is about 10^{-25} times the GUT energy. As a consequence, the measurement precision of any observable is limited to about 25 digits.* The present precision record is about 15 digits, and for the electromagnetic coupling constant it is about 9 digits. The prediction can thus be tested only in quite some time.

The fun is thus to find a system in which the spreading coupling constant value appears more clearly in the measurements. For example, it might be that high precision measurements of the g -factor of elementary particles or high energy cosmic ray reactions can show some effects of the fan-out. Also the lifetime of elementary particles could be affected. Can you find another effect?

In summary, the experimental detection of quantum gravity effects should be possible, despite their weakness, during the 21st century. The successful detection of any such effect

* It might be that the correct energy of everyday life has to be taken as the electron rest energy; that would change the prediction to only 19 digits for the maximum precision.

will be one of the highlights of physics, as it will challenge the usual description of space and time even more than general relativity did.

We now know that the fundamental entity describing space-time and matter we are looking for is not point-like. How does it look? To get to the top of motion mountain as rapidly as possible, we make use of some explosives to blast away some disturbing obstacles.

References

- 1 STEVEN WEINBERG, *The cosmological constant problem*, *Reviews of Modern Physics* **61**, pp. 1–23, 1989. Cited on page 669.
- 2 STEVEN WEINBERG, *The quantum theory of fields*, Cambridge University Press, volume I, 1995, and II, 1996. Cited on page 669.
- 3 The difficulties are summarized by B.S. DE WITT, *Quantum field theory in curved space-time*, *Physics Reports* **19**, pp. 295–357, 1975. Cited on page 670.
- 4 C.W. MISNER & K.S. THORNE, J.A. WHEELER, *Gravitation*, Freeman, 1973. Cited on page 670, 672, 677.
- 5 J.A. WHEELER, in *Relativity, Groups, and Topology*, edited by C. DeWitt & B. DeWitt (Gordon and Breach, 1994). See also J.A. WHEELER, *Physics at the Planck length*, *International Journal of Modern Physics A* **8**, pp. 4013–4018, 1993. Cited on page 670.
- 6 J.L. FRIEDMAN & R.D. SORKIN, *Spin 1/2 from gravity*, *Physical Review Letters* **44**, pp. 1100–1103, 1980. Cited on page 670.
- 7 A.P. BALACHANDRAN, G. BIMONTE, G. MARMO & A. SIMONI, *Topology change and quantum physics*, *Nuclear Physics B* **446**, pp. 299–314, 1995, also preprint hep-th/9503046. Cited on page 670.
- 8 Many themes here resulted from an intense exchange with Luca Bombelli, now at the Department of Physics and Astronomy of the University of Mississippi. These pages are a reworked version of the ones published in French as CHRISTOPH SCHILLER, *Le vide diffère-t-il de la matière?*, in E. GUNZIG & S. DINER, éditeurs, *Le vide – Univers du tout et du rien – Des physiciens et des philosophes s’interrogent*, Les Éditions de l’Université de Bruxelles, 1998. An older English version is also available as CHRISTOPH SCHILLER, *Does matter differ from vacuum?*, <http://xxx.lanl.gov/abs/gr-qc/9610066>. Cited on page 671.
- 9 See for example R.P. FEYNMAN, *The Feynman lectures of physics*, Addison Wesley, 1963. Cited on page 671.
- 10 A. ASHTEKAR, *Recent mathematical developments in quantum general relativity*, preprint gr-qc/9411055. C. ROVELLI, *Ashtekar Formulation of general relativity and loop-space non-perturbative quantum gravity: a report*, *Classical and Quantum Gravity* **8**, pp. 1613–1675, 1991. Cited on page 671, 691.
- 11 M.B. GREEN, J.H. SCHWARZ & E. WITTEN, *Superstring theory*, volume 1 and 2 (Cambridge University Press, 1987). G. VENEZIANO, *A stringy nature needs just two constants*, *Europhysics Letters* **2**, pp. 199–204, 1986. Cited on page 671, 691.
- 12 S. MAJID, *Introduction to Braided Geometry and q-Minkowski Space*, preprint hep-th/9410241. See also S. MAJID, *Beyond supersymmetry and quantum symmetry (an introduction to braided groups and braided matrices)*, in *Quantum groups, integrable statistical models, and knot theory*, edited by M.-L. GE & H.J. DE VEGA, World Scientific, 1993, pp. 231–282. Cited on page 671, 691.
- 13 C.J. ISHAM, *Prima facie questions in quantum gravity*, preprint gr-qc/9310031. Cited on page 671.

- 14 STEVEN WEINBERG, *Gravitation and Cosmology*, (Wiley, 1972). Cited on page 672, 676, 677.
- 15 The observations of black holes at the centre of galaxies and elsewhere are summarized by R. BLANDFORD & N. GEHRELS, *Revisiting the black hole*, *Physics Today* **52**, June 1999. Cited on page 672.
- 16 M. PLANCK, *Über irreversible Strahlungsvorgänge*, *Sitzungsberichte der Kaiserlichen Akademie der Wissenschaften zu Berlin*, pp. 440–480, 1899. Today it is commonplace to use Dirac's \hbar instead of Planck's h , which Planck originally called b . Cited on page 674.
- 17 The argument is given e.g. in E.P. WIGNER, *Relativistic invariance and quantum phenomena*, *Reviews of Modern Physics* **29**, pp. 255–258, 1957. Cited on page 675.
- 18 The starting point for the following arguments is taken from M. SCHÖN, *Operative time definition and principal uncertainty*, preprint hep-th/9304024, and from T. PADMANABHAN, *Limitations on the operational definition of space-time events and quantum gravity*, *Classical and Quantum Gravity* **4**, pp. L107–L113, 1987; see also his earlier papers referenced there. Cited on page 675.
- 19 W. HEISENBERG, *Über den anschaulichen Inhalt der quantentheoretischen Kinematik und Mechanik*, *Zeitschrift für Physik* **43**, pp. 172–198, 1927. Cited on page 675.
- 20 E.H. KENNARD, *Zur Quantenmechanik einfacher Bewegungstypen*, *Zeitschrift für Physik* **44**, pp. 326–352, 1927. Cited on page 675.
- 21 M.G. RAYMER, *Uncertainty principle for joint measurement of noncommuting variables*, *American Journal of Physics* **62**, pp. 986–993, 1994. Cited on page 675.
- 22 H. SALECKER & E.P. WIGNER, *Quantum limitations of the measurement of space-time distances*, *Physical Review* **109**, pp. 571–577, 1958. Cited on page 676.
- 23 E.J. ZIMMERMAN, *The macroscopic nature of space-time*, *American Journal of Physics* **30**, pp. 97–105, 1962. Cited on page 676.
- 24 S.W. HAWKING, *Particle creation by black holes*, *Communications in Mathematical Physics* **43**, pp. 199–220, 1975; see also S.W. HAWKING, *Black hole thermodynamics*, *Physical Review D* **13**, pp. 191–197, 1976. Cited on page 676.
- 25 P. GIBBS, *The small structure of space-time: a bibliographical review*, preprint hep-th/9506171. Cited on page 676, 689.
- 26 C.A. MEAD, *Possible connection between gravitation and fundamental length*, *Physical Review B* **135**, pp. 849–862, 1964. Cited on page 676, 677, 679, 697.
- 27 P.K. TOWNSEND, *Small-scale structure of space-time as the origin of the gravitational constant*, *Physical Review D* **15**, pp. 2795–2801, 1977. Cited on page 677.
- 28 M.-T. JAEKEL & S. RENAUD, *Gravitational quantum limit for length measurement*, *Physics Letters A* **185**, pp. 143–148, 1994. Cited on page 677.
- 29 D.V. AHLUWALIA, *Quantum measurement, gravitation, and locality*, *Physics Letters B* **339**, pp. 301–303, 1994, also preprint gr-qc/9308007. Cited on page 677.
- 30 L. GARAY, *Quantum Gravity and minimum length*, *International Journal of Modern Physics A* **10**, pp. 145–165, 1995, also preprint gr-qc/9403008; this paper also includes an extensive bibliography. Cited on page 677.
- 31 G. AMELINO-CAMELIA, *Limits on the measurability of space-time distances in (the semi-classical approximation of) quantum gravity*, *Modern Physics Letters A* **9**, pp. 3415–3422, 1994, also preprint gr-qc/9603014. See also Y.J. NG & H. VAN DAM, *Limit to space-time measurement*, *Modern Physics Letters A* **9**, pp. 335–340, 1994. Cited on page 677.

- 32** The generalized uncertainty relation is an implicit part of reference [26](#), especially on page 852, but the issue is explained rather unclearly. Obviously the author found the result too simple to be mentioned explicitly. Cited on page [677](#), [678](#).
- 33** C. ROVELLI & L. SMOLIN, *Discreteness of area and volume in quantum gravity*, Nuclear Physics B **442**, pp. 593–619, 1995. R. LOLL, *The volume operator in discretized quantum gravity*, preprint gr-qc/9506014. Cited on page [678](#).
- 34** D. AMATI, M. CIAFALONI & G. VENEZIANO, *Superstring collisions at Planckian energies*, Physics Letters B **197**, pp. 81–88, 1987. D.J. GROSS & P.F. MENDE, *The high energy behavior of string scattering amplitudes*, Physics Letters B **197**, pp. 129–134, 1987. K. KONISHI, G. PAFFUTI & P. PROVERO, *Minimum physical length and the generalized uncertainty principle*, Physics Letters B **234**, pp. 276–284, 1990. P. ASPINWALL, *Minimum Distances in Non-Trivial String Target Spaces*, Nuclear Physics B **431**, pp. 78–96, 1994, also preprint hep-th/9404060. Cited on page [678](#).
- 35** M. MAGGIORE, *A generalized uncertainty principle in quantum mechanics*, Physics Letters B **304**, pp. 65–69, 1993. Cited on page [678](#).
- 36** A simple approach is S. DOPLICHER, K. FREDENHAGEN & J.E. ROBERTS, *Space-time quantization induced by classical gravity*, Physics Letters B **331**, pp. 39–44, 1994, Cited on page [678](#), [688](#).
- 37** A. KEMPF, *Uncertainty relation in quantum mechanics with quantum group symmetry*, Journal of Mathematical Physics **35**, pp. 4483–4496, 1994. A. KEMPF, *Quantum Groups and quantum field theory with Nonzero minimal uncertainties in positions and momenta*, Czechoslovak Journal of Physics **44**, pp. 1041–1048, 1994. Cited on page [678](#).
- 38** E.J. HELLUND & K. TANAKA, *Quantized space-time*, Physical Review **94**, pp. 192–195, 1954. Cited on page [678](#).
- 39** The impossibility to determine temporal ordering in quantum theory is discussed by J. OPPENHEIMER, B. REZNIK & W.G. UNRUH, *Temporal ordering in quantum mechanics*, ... 2001. Cited on page [679](#).
- 40** A. PERES & N. ROSEN, *Quantum Limitations on the measurement of gravitational fields*, Physical Review **118**, pp. 335–336, 1960. Cited on page [679](#).
- 41** It is the first definition in Euclid's *Elements*, ca. 300 BCE. For an English translation see T. HEATH, *The thirteen books of the elements*, Dover, 1969. Cited on page [680](#).
- 42** A beautiful description of the Banach-Tarski paradox is the one by IAN STEWART, *Paradox of the spheres*, New Scientist, 14 January 1995, pp. 28–31. Cited on page [680](#).
- 43** H.S. SNYDER, *Quantized space-time*, Physical Review **71**, pp. 38–41, 1947. H.S. SNYDER, *The electromagnetic field in quantized of space-time*, Physical Review **72**, pp. 68–74, 1947. A. SCHILD, *Discrete space-time and integral Lorentz transformations*, Physical Review **73**, pp. 414–415, 1948. E.L. HILL, *Relativistic theory of discrete momentum space and discrete space-time*, Physical Review **100**, pp. 1780–1783, 1950. H.T. FLINT, *The quantization of space-time*, Physical Review **74**, pp. 209–210, 1948. A. DAS, *Cellular space-time and quantum field theory*, Il Nuovo Cimento **18**, pp. 482–504, 1960. Cited on page [682](#).
- 44** D. FINKELSTEIN, *'Superconducting' causal nets*, International Journal of Theoretical Physics **27**, pp. 473–519, 1985. Cited on page [682](#).
- 45** N.H. CHRIST & R. FRIEDBERG, T.D. LEE, *Random lattice field theory: general formulation*, Nuclear Physics B **202**, pp. 89–125, 1982. G. 'T HOOFT, *Quantum field theory for elementary particles – is quantum field theory a theory?*, Physics Reports **104**, pp. 129–142, 1984. Cited on page [682](#).
- 46** See for example L. BOMBELLI, J. LEE, D. MEYER & R.D. SORKIN, *Space-time as a causal set*, Physical Review Letters **59**, pp. 521–524, 1987. G. BRIGHTWELL & R.

- GREGORY, *Structure of random space-time*, Physical Review Letters **66**, pp. 260–263, 1991. Cited on page 682.
- 47 For a discussion, see R. SORABJI, *Time, creation, and the continuum*, Cited on page 682.
- 48 A.D. SAKHAROV, *Vacuum quantum fluctuations in curved space and the theory of gravitation*, Soviet Physics – Doklady, **12**, pp. 1040–1041, 1968. Cited on page 684.
- 49 C. WOLF, *Upper limit for the mass of an elementary particle due to discrete time quantum mechanics*, Il Nuovo Cimento B **109**, pp. 213–218, 1994. Cited on page 684.
- 50 W. BERNREUTHER & M. SUZUKI, *The electric dipole moment of the electron*, Reviews of Modern Physics **63**, pp. 313–340, 1991. N.F. RAMSEY & A. WEIS, *Suche nach permanenten elektrischen Dipolmomenten: ein Test der Zeitumkehrinvarianz*, Physikalische Blätter **52**, pp. 859–863, 1996. See also the musings in HANS DEHMELT, *Is the electron a composite particle?*, Hyperfine Interactions **81**, pp. 1–3, 1993. Cited on page 685, 693.
- 51 W.G. UNRUH, *Notes on black hole evaporation*, Physical Review D **14**, pp. 870–875, 1976. W.G. UNRUH & R.M. WALD, *What happens when an accelerating observer detects a Rindler particle*, Physical Review D **29**, pp. 1047–1056, 1984. Cited on page 688.
- 52 W. JAUCH, *Heisenberg’s uncertainty relation and thermal vibrations in crystals*, American Journal of Physics **61**, pp. 929–932, 1993. Cited on page 688.
- 53 H.D. ZEH, *On the interpretation of measurement in quantum theory*, Foundations of Physics **1**, pp. 69–76, 1970. Cited on page 689.
- 54 One way out is proposed in J. MAGUEIJO & L. SMOLIN, *Lorentz Invariance with an Invariant Energy Scale*, Physical Review Letters **88**, p. 190403, 26 April 2002. They propose a modification of the mass energy relation of the sort

$$E = \frac{\gamma mc^2}{1 + \frac{\gamma mc^2}{E_{Pl}}} \quad \text{and} \quad p = \frac{\gamma mv}{1 + \frac{\gamma mc^2}{E_{Pl}}} \quad . \quad (551)$$

Cited on page 689.

- 55 B.E. SCHAEFER, *Severe limits on variations of the speed of light with frequency*, Physical Review Letters **82**, pp. 4964–4966, 21 June 1999. Cited on page 691.
- 56 G. AMELINO-CAMELIA, J. ELLIS, N.E. MAVROMATOS, D.V. NANOPOULOS & S. SAKAR, *Potential sensitivity of gamma-ray-burster observations to wave dispersion in vacuo*, Nature **393**, p. 763, 1998, and preprint <http://arxiv.org/astro-ph/9712103>. Cited on page 691.
- 57 G. AMELINO-CAMELIA, *Phenomenological description of space-time foam*, preprint <http://arxiv.org/gr-qc/0104005>, 2001. The paper includes a clearly written overview of present experimental approaches to detect quantum gravity effects. Cited on page 691, 691, 691.
- 58 L.J. GARAY, *Spacetime foam as a quantum thermal bath*, Physics Review Letters **80**, pp. 2508–2511, 1998, also downloadable as <http://www.arxiv.org/gr-qc/9801024>. Cited on page 691, 692.
- 59 At the unification scale, all particles are of the same type. See for example ... Cited on page 692.
- 60 G. AMELINO-CAMELIA, *An interferometric gravitational wave detector as a quantum gravity apparatus*, Nature **398**, p. 216, 1999, and preprint <http://arxiv.org/gr-qc/9808029>. Cited on page 691.
- 61 G. AMELINO-CAMELIA & T. PIRAN, *Planck scale-deformation of Lorentz symmetry as a solution to the UHECR and the TeV γ paradoxes*, preprint <http://arxiv.org/astro-ph/0008107>, 2000. Cited on page 691.
- 62 See the paper by U. AMALDI, W. DE BOER & H. FÜRSTENAU, *Comparison of grand unified theories with elektroweak and strong coupling constants measured at LEP*, Physics Letters **260**, pp. 447–455, 1991. This is the standard reference on the topic. Cited on page 693, 694.

- 63** M.V. ROMALIS, W.C. GRIFFITH, J.P. JACOBS & E.N. FORTSON, *New limit on the permanent electric dipole moment of ^{199}Hg* , Physical Review Letters **86**, pp. 2505–2508, 19 March 2001, or [arxiv.org/hep-ex/0012001](https://arxiv.org/abs/hep-ex/0012001). Cited on page 693.



32. Nature at large scales – is the universe something or nothing?

Die Grenze ist der Ort der Erkenntnis.*
Paul Tillich

This strange question is the topic of the present leg of our mountain ascent. We explored the properties of nature in the vicinity of Planck dimensions in the previous section; it is equally fascinating to explore the other limit, namely to study the description of motion at large, cosmological scales. Step by step many incredible results will appear, and at the end we will discover a surprising answer to the title question.

Ref. 1

This section is not standard textbook material; a large part is original** and thus speculative and questionable. Even though it aims at explaining in simple words the ongoing research in the domains of quantum gravity and superstring theory, watch out. For every sentence of this section you will find at least one physicist disagreeing !

We have studied the universe several times already. In classical physics we enquired about its initial conditions, and whether it is isolated. In the first intermezzo we asked whether the universe is a set, a concept, and whether it exists. In general relativity we gave the classical definition of the term, as sum of all matter and space-time, studied the expansion of the universe and asked about its size and topology. In quantum theory we asked whether the universe has a wavefunction, whether it is born from a quantum fluctuation, and whether it allows to define a particle number.

Typeset in
July 2002

Here we will settle all these issues by combining general relativity and quantum theory at cosmological scales. That will lead us to some of the strangest results we will encounter in our hike.

Cosmological scales

Hic sunt leones.***

The description of motion requires general relativity whenever the scales d of the situation are of the order of the Schwarzschild radius, i.e. whenever

$$d \approx r_S = 2Gm/c^2 \quad . \quad (552)$$

It is straightforward to confirm that with the usually quoted mass and size of all visible components of the universe, this condition is indeed fulfilled. We do need general relativity and thus curved space-time when talking about the whole of nature.

Challenge 815

Similarly, quantum theory is required for the description of motion of an object whenever we approach it to distances d of the order of the Compton wavelength, i.e. whenever

$$d \approx \lambda_C = \frac{h}{mc} \quad . \quad (553)$$

* The frontier is the place of understanding.

** Written between June and December 2000.

*** 'Here are lions.' Written in ancient maps across unknown and dangerous regions.

Obviously, for the total mass of the universe this condition is not fulfilled. But we are not interested in the motion of the universe itself; we are interested in the motion of its components. For their description, quantum theory is required whenever pair production and annihilation play a role. Especially in the early history of the universe and near the horizon, i.e. for the most distant events we can observe in space and time, this is indeed the case. We are thus obliged to include quantum theory in any precise description of the universe.

Since at cosmological scales we need both quantum theory and general relativity, we start our investigation with the study of time, space, and mass, by asking at large scales the same questions we asked above at Planck scales.

Maximum time

Is it possible to measure time intervals of any imaginable size? General relativity shows that in nature there is a maximum time interval, with a value of about twelve thousand million years or 380 Ps, providing an upper limit to time measurements. It is called the ‘age’ of the universe. It is deduced from two sets of measurements: the expansion of space-time, and the age of matter.

Challenge 832

We all know clocks ticking for long times: the hydrogen atoms in our body. They were formed just after the big bang. We can almost say that their electrons orbit the nuclei since the dawn of time. In fact, inside their protons, the quarks move for even a few hundred thousand years longer. We thus get a common maximum time limit for any clock made of atoms. Even clocks made of radiation (can you describe one?) yield a similar maximum time. In fact, no imaginable clock has been ticking *before* this maximum time; none could provide a record of having done so. On the contrary, all known arguments maintain that clocks have not been ticking before.

In summary, it is *not* possible to measure time intervals larger than the maximum one, neither by using the history of space-time nor by using the history of matter or radiation.* It is thus rightly called the ‘age’ of the universe. Of course, all this is not a surprise. But looking at the issue in more detail is.

Does the universe have a certain age?

One should never trust a woman who tells one her real age.
A woman who would tell one that,
would tell one anything.
Oscar Wilde

See page 822

This seems a silly question, since we just talked about it; in addition, the value is found in many books and tables, including that of Appendix B, and its precise determination is actually one of the most important quests in modern astrophysics. But is this quest reasonable?

In order to measure the duration of a movement or the age of a system, we need a clock. The clock has to be *independent* of that movement and thus has to be *outside* the system. However, there are no clocks outside the universe. Inside it, a clock cannot be independent. In fact we just saw that inside the universe, no clock can run during *all* its history. Indeed,

* This conclusion implies that so-called ‘oscillating’ universe models, in which it is claimed that ‘before’ the big bang there are other phenomena, have nothing to do with nature or observations.

time can be defined only once matter and space-time can be distinguished. And from this distinction onwards, only the two possibilities just discussed remain: we can either talk about the age of space-time, as is done in general relativity, by assuming that matter provides suitable clocks; or we can talk about the age of matter, such as stars or galaxies, by assuming that either space-time extension or some other matter provides the clock. Both possibilities are being explored experimentally by modern astrophysics, and give the same mentioned result of about twelve thousand million years. But for the universe as a *whole*, an age cannot be defined.

The issue of the starting point of time makes this difficulty even more apparent. We might imagine that going back in time, there should be only two possibilities: either the instant $t = 0$ is part of time or it is not. (Mathematically, this means that the segment describing time should be either closed or open.) Both cases assume that it is possible to measure arbitrary small times. But we know from the combination of general relativity and of quantum theory that this is *not* the case. In other words, both possibilities are incorrect: the beginning cannot *be* part of time, nor can it *not be* part of it. To this situation there is only one solution: there has not been any beginning at all.

In other words, the situation is consistently muddled. Neither does the age of the universe make sense, nor does its origin. What goes wrong? Or better, *how* do things go wrong? In other words, what happens if instead of jumping at the big bang directly, we *approach* it as much as possible? The best way to clarify the issue is to ask about the measurement *error* we make when saying that the universe is twelve thousand million years old. This turns out to be a fascinating topic.

How precisely can ages be measured?

No woman should ever be quite accurate about her age.
It looks so calculating.
Oscar Wilde

The first way to measure the age of the universe* is to look at clocks in the usual sense of the term, namely clocks made of *matter*. As explained in the part on quantum theory, Salecker and Wigner showed that a clock built to measure a total time T with a precision Δt has a minimum mass m given by Ref. 3

$$m > \frac{\hbar}{c^2} \frac{T}{(\Delta t)^2} . \quad (554)$$

A simple way to include general relativity into this result was suggested by Ng and Van Dam. Any clock of mass m has a minimum resolution Δt due to the curvature of space it introduces, given by Ref. 4

$$\Delta t > \frac{Gm}{c^3} . \quad (555)$$

* Note that the age t_0 is not the same as the Hubble time $T = 1/H_0$. The Hubble time is only a computed quantity and (almost) always larger than the age; the relation between the two depends on the value of the cosmological constant, the density, and on other parameters of the universe. For example, for the standard hot big bang scenario, i.e. for the matter dominated Einstein-de Sitter model, we have the simple relation $T = (3/2)t_0$. Ref. 2

Eliminating m , these two results imply that any clock with a precision Δt can only measure times T up to a certain maximum value, namely

$$T < \frac{(\Delta t)^3}{t_{\text{Pl}}^2}, \quad (556)$$

where $t_{\text{Pl}} = \sqrt{\hbar G/c^5} = 5.4 \cdot 10^{-44}$ s is the already familiar Planck time. (As usual, we have *omitted* factors of order one in this and all the following results of this section.) In other words, the higher the accuracy of a clock, the shorter the time the clock works dependably! The precision of a clock is not (only) limited by the budget spent to build it, but by nature itself. Nevertheless, it does not take much to check that for clocks in daily life, this limit is not even remotely reached. For example, you might want to deduce how precisely your own age can be specified.

Challenge 849

As a consequence of (556), a clock trying to achieve an accuracy of one Planck time can do so for at most one single Planck time! Simply put, *a real clock cannot achieve Planck time accuracy*. If we try to go beyond limit (556), fluctuations of space-time hinder the working of the clock and prevent higher precision. With every Planck time passing by, the clock accumulates at least one Planck time of measuring error. At the end, the total measurement error is at least as large as the measurement result itself. We note in passing that the conclusion is also valid for clocks made of radiation, such as background radiation.

Challenge 866

In short, measuring an age with a clock always involves some errors; whenever we try to reduce these errors, the clock becomes so imprecise that age measurements become impossible.

Does time exist?

Time is waste of money.
Oscar Wilde

See page 40

From the origins of physics onwards, the concept of ‘time’ has been the name for what is measured by a clock. Therefore equation (556), expressing the non-existence of perfect clocks, also implies that time is only an approximate concept, and that perfect time does not exist. Thus there is no ‘idea’ of time, in the sense of Plato. In fact, all discussions of the previous and the present section can be seen as proofs that there are no perfect or ‘ideal’ examples of any classical or everyday concept.

Challenge 883

Despite this conclusion, time is obviously a useful concept in everyday life. A simple explanation appears when we focus on the importance of *energy*. Any clock, in fact any system of nature, is characterized by a simple number, namely the highest fraction of kinetic energy to rest energy of its components. In daily life, this fraction is about $1 \text{ eV}/10 \text{ GeV} = 10^{-10}$. Such *low energy* systems are well suited to build clocks. The better the motion of the main moving part – the pointer of the clock – can be kept constant and be monitored, the better the precision of the clock. To achieve the highest possible clock precision, the highest possible mass of the pointer is required; indeed, both its position and speed must be measured, while the two measurement errors are related by $\Delta v \Delta x > \hbar/m$. This requires even more mass to screen the pointer from outside influences, thus possibly explaining why more money usually buys better clocks.

But the relation is valid only at everyday energies. Increasing the mass is not possible without bounds, since general relativity changes the right hand side to $\Delta v \Delta x > \hbar/m + G(\Delta v)^2 m/c^3$. The additional term, negligible at everyday scales, is proportional to mass *and* energy fraction. Increasing either of the two by too large an amount limits the achievable precision of the clock. And thus at Planck energies the maximum measurable time interval is given by the Planck time.

Ref. 1

See page 677

Challenge 900

In summary, time exists as a good approximation only for *low energy* systems. Any increase in precision beyond a certain limit would require an increase of the energy of the components; but this energy increase will then prevent the increase in precision.

What is the measurement error for the age of the universe?

Applying the discussion about time measurements to the age of the universe is now straightforward. Expression (556) implies that the highest precision possible for a clock is about 10^{-23} s, or about the time light takes to move across a proton. The finite age of the universe also yields also a maximal *relative* measurement precision. Expression (556) can be written as

Challenge 917

$$\frac{\Delta t}{T} > \left(\frac{t_{\text{Pl}}}{T}\right)^{2/3} \quad (557)$$

which shows that no time interval can be measured with more than about 40 decimals.

In order to clarify the issue we calculate the measurement error as function of the observation energy. We get two limits. For *small* energies, the error is given by quantum theory as

$$\frac{\Delta t}{T} \sim \frac{1}{E_{\text{meas}}} \quad (558)$$

and thus goes down with measurement energy. For high energies, the error is given by gravitational effects by

$$\frac{\Delta t}{T} \sim \frac{E_{\text{meas}}}{E_{\text{Pl}}} \quad (559)$$

so that the total result is given in Figure 231. In particular, too high energies do not help to reduce measurement errors, as any attempt to reduce the measurement error for the age of the universe below 10^{-23} s would require energies so high that the limits of space-time would be reached, making the measurement itself impossible.

But maybe this conclusion was due to the fact that the argument used clocks made of particles, either of matter or of radiation. In the following we will find a confirmation of this limit, as well as more details, by looking at the methods to determine the age of the universe from space-time.

Imagine you see a tree which, due to some wind storm, fell towards another, touching it at the very top. It is possible to determine the height of both trees by measuring the separation and the angles at the base. The height *error* will depend on the measurement errors of the separation and of the angles. Similarly, the age of the universe follows from the distance and the speed of objects, such as galaxies, observed in the night sky. The distance d corresponds

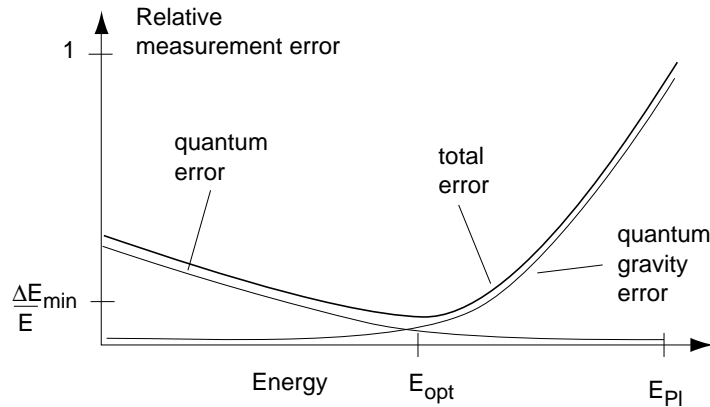

Figure 231 Measurement errors as a function of measurement energy

to the ground separation of the trees and the speed v to the angle between the two trees. The Hubble time T of the universe – as already mentioned, it is usually assumed to be larger than the age of the universe – then corresponds to the height at which the two trees meet, since the age starts, in a naive sense, when the galaxies ‘separated’. That time is given, within a factor of order one, by

$$T = \frac{d}{v} . \tag{560}$$

This is in simple words the method used to determine the age of the universe from the expansion of space-time, for galaxies with redshifts below unity.* Of interest in the following is the (positive) measurement error ΔT , which becomes

$$\frac{\Delta T}{T} = \frac{\Delta d}{d} + \frac{\Delta v}{v} ; \tag{561}$$

exploring it in more detail is worthwhile. For any measurement of T we have to choose the object, i.e. a distance d , as well as an observation time Δt , or equivalently, an observation energy $\Delta E = 2\pi\hbar/\Delta t$. We will now investigate the consequences of these choices for expression (561), always taking into account both quantum theory *and* general relativity.

At everyday energies, the result of the determination of the age t_0 is about $12 \pm 2 \cdot 10^9$ years. The value is deduced by measuring red shifts, i.e. velocities, and distances, for stars and galaxies in distance ranges from some hundred thousand light years up to a red shift of about 1. Measuring redshifts does not produce large velocity errors. The main source of experimental error is the difficulty to determine galaxy distances.

What is the smallest possible distance error? Obviously, equation (557) implies

$$\frac{\Delta d}{T} > \frac{l_{Pl}^{2/3}}{d^{2/3}} \tag{562}$$

thus giving the same age uncertainty for the universe as found above in the case of material clocks.

Challenge 951

* At higher redshifts, the speed of light as well as the details of the expansion come into play; in the image of inclined trees, we find that the trees are not straight all the way up to the top, and that they grow on a slope, as shown in Figure 233.

This is a section of the freely downloadable e-textbook

Motion Mountain

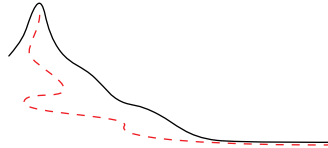

Hiking beyond space and time along the concepts of modern physics

available at
www.motionmountain.org

Copyright © 1997, 1998, 1999, 2000, 2001, 2002 by Christoph Schiller

To the kind reader

In exchange for getting this section for free, I ask you for a short email on some of the following:

- Which page was boring?
- Did you find any mistakes?
- What else were you expecting?
- What was hard to understand?

Of course, any other suggestion is welcome. This section is part of a physics text written over many years. The text lives and grows through the feedback from its readers, who help to improve and to complete it. For a particularly useful contribution (send it in english, italian, dutch, german, spanish, portuguese, or french) you will be mentioned in the foreword of the text, or receive a small reward, or both.

Enjoy!

Christoph Schiller
cs@motionmountain.org

Challenge 934

Challenge 968

We can try to reduce this error in two ways: either choosing objects at small or at large distances. Let us start with the smallest possible distances. In order to get high precision at small distances, we need high observation energies. It does not take much to note that at observation energies near the Planck value, the value of $\Delta T/T$ approaches unity. In fact, both terms on the right hand side of expression (561) become of order one. At these energies, Δv approaches c and the maximum value for d approaches the Planck length, for the same reason that at Planck energies the maximum measurable time is the Planck time. In short, *at Planck scales it is impossible to say whether the universe is old or young.*

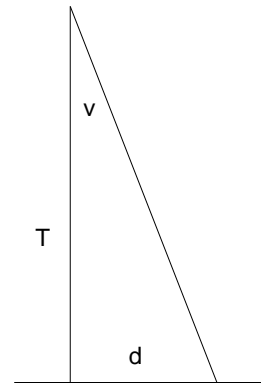

Figure 232 Trees and galaxies

Let us continue with the other extreme, namely objects extremely far away, say with a redshift of $z \gg 1$. Relativistic cosmology requires the diagram of Figure 232 to be replaced by the more realistic diagram of Figure 233. The ‘light onion’ replaces the familiar light cone of special relativity: light converges near the big bang.

Ref. 2

Also in this case the measurement error for the age of the universe depends on the distance and velocity errors. At the largest possible distances, the signals an object must send away must be of high energy, because the emitted wavelength must be smaller than the universe itself. We inevitably reach Planck energies. But we saw that in such high energy situations, the emitted radiation, as well as the object itself, are indistinguishable from the space-time background. In other words, the redshifted signal we would observe today would have a wavelength as large as the size of the universe, with a correspondingly small frequency.

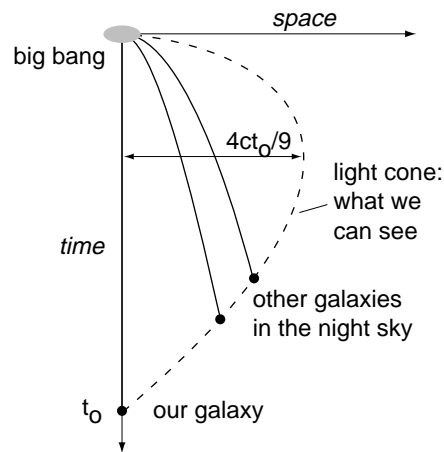

Figure 233 Speed and distance of remote galaxies

Another way to describe the situation is the following. At Planck energies or near the horizon, the original signal has an error of the same size as the signal itself. At present time, the redshifted signal still has an error of the same size as the signal. As a result, for large distances the error on the horizon distance becomes as large as the value to be measured.

In short, even using space-time expansion and large scales, the instant of the so-called beginning of the universe cannot be determined with an error smaller than the age of the universe itself, a result we also found at Planck distances. Whenever we aim for perfect precision, we find that the universe is 12 ± 12 thousand million years old! In other words, *at both extremal situations it is impossible to say whether the universe has a non-vanishing age.*

We have to conclude that the anthropomorphic concept of ‘age’ does not make any sense for the universe as a whole. The usual textbook value is useful only for domains in time,

space and energy for which matter and space-time are clearly distinguished, namely at everyday, *human scale* energy; however, this anthropocentric value has no overall meaning.

By the way, you might like to discuss the issue of the *fate* of the universe using the same arguments. Here however, we continue on the path outlined at the start of this section; the next topic is the measurement of length.

Challenge 985

Maximum length

General relativity shows that in the standard cosmological model, for hyperbolic (open) and parabolic (marginal) universe evolutions, the actual *size* of the universe is infinite. It is only the *horizon distance*, i.e. the distance of objects with infinite redshift, which is finite. In a hyperbolic or parabolic universe, even though the size is infinite, the most distant visible events (which form the horizon) are at finite distance.* For elliptical evolution, the total size is finite and depends on the curvature; but also in this case the present measurement limit yields a minimum size for the universe many times larger than the horizon distance. At least, this is what general relativity says.

See page 295

On the other hand, quantum field theory is based on flat and infinite space-time. Let us see what happens when both theories are combined. What can we say about length measurements in this case? For example, would it be possible to construct and use a meter bar to measure lengths larger than the distance to the horizon? It is true that we would have no time to push it up to there, since in the standard Einstein-de Sitter big bang model the horizon moves away from us with more than the speed of light. We should have started installing the meter bar right at the big bang.

Ref. 2

For fun, let us assume that we actually managed to do this. How far could we read off distances? In fact, since the universe was smaller in the past, and since every observation of the sky is an observation of the past, Figure 233 shows that the maximum *spatial distance* an object can be seen away from us is only $(4/9)ct_0$. Obviously, for space-time intervals, the maximum remains ct_0 .

Ref. 2

In all cases it thus turns out to be impossible to measure lengths larger than the horizon distance, even though general relativity predicts such distances. This unsurprising result is in obvious agreement with the existence of a limit for time interval measurements. The real surprises come now.

Is the universe really a big place?

Astronomers and Hollywood movies answer by the affirmative. Indeed, the horizon distance of the universe is usually included in tables. Cosmological models specify that the scale factor R , which fixes the horizon distance, grows with time; for the case of the usually assumed mass dominated Einstein-de Sitter model, i.e. for vanishing cosmological constant

Ref. 5

See page 822

* In cosmology, we need to distinguish between the scale factor R , the Hubble radius $c/H = cR/\dot{R}$, the horizon distance h , and the size d of the universe. The Hubble radius is a computed quantity giving the distance at which objects move away with the speed of light. It is always *smaller* than the horizon distance, at which e.g. in the standard Einstein-de Sitter model objects move away with *two* times the speed of light. However, the horizon itself moves away with *three* times the speed of light.

Ref. 2

and flat space, we have

$$R(t) = C t^{2/3} \quad , \quad (563)$$

where the constant C relates the commonly accepted horizon distance to the commonly accepted age. Indeed, observation shows that the universe is large and is still getting larger. But let us investigate what happens if to this result from general relativity we add the limitations of quantum theory. Is it really possible to measure the distance to the horizon?

We first look at the situation at high energies. We saw above that space-time and matter are not distinguishable at Planck scales. Therefore, at Planck energy we cannot state whether objects are *localized* or not. At Planck scales, a basic distinction of our thinking, namely the one between matter and vacuum, becomes obsolete. Equivalently, it is not possible to claim that space-time is *extended* at Planck scales. Our concept of extension derives from the possibility to measure distances and time intervals, and from observations such as the ability to align several objects, e.g. in one room, behind each other. Such observations are not possible at Planck scales. In fact, none of the observations in daily life from which we deduce that space is extended are possible at Planck scales. *At Planck scales, the basic distinction between vacuum and matter, extension and localization, disappears.* As a consequence, at Planck energies the size of the universe cannot be measured. It cannot even be called larger than a match box.

Challenge 1002

At cosmological distances, the situation is even easier. All arguments given above on the measurement errors for the age can be repeated for the distance of the horizon. Essentially, at largest distances and at Planck energies, the measurement errors are of the same magnitude as the measured value. All this happens because length measurements become impossible at nature's limits. This is corroborated by the lack of any standard with which to compare the size of the universe.

Also studying the big bang produces strange results. At Planck energies, whenever we try to determine the size of the big bang, we cannot claim that it was smaller than the present universe. Somehow, Planck dimensions and the size of the universe get confused.

Challenge 1019

There are also other confirmations. Let us come back to the example above. If we had a meter bar spanning all the universe, even beyond the horizon, with a zero at the place we live, what measurement *error* would it produce for the horizon? It does not take long to discover that the expansion of space-time from Planck scales to the present also expands an uncertainty of the Planck size into one of the horizon size. The error is as large as the measurement result.

Since this also applies when we try to measure the *diameter* of the universe instead of its radius, it becomes impossible to state whether the antipodes in the sky really are distant from each other!

We summarize the situation by noting that anything said about the size of the universe is as limited as anything said about its age. *The height of the sky depends on the observation energy.* At Planck energies, it cannot distinguished from the Planck length. If we start measuring the sky at standard observation energies, trying to increase the measurement precision of the distance to the horizon, the measurement error increases beyond all bounds. At Planck energies, the volume of the universe is indistinguishable from the Planck volume!

The boundary of space-time – is the sky a surface?

The horizon of the universe, essentially the black part of the night sky, is a fascinating entity. Everybody interested in cosmology wants to know what happens there. In newspapers the horizon is sometimes called the *boundary of space-time*. Some surprising insights, not yet common in newspapers, appear when the approaches of general relativity and quantum mechanics are combined.

We saw above that the measurement errors for the distance of the horizon are substantial. They imply that we cannot pretend that all points of the sky are equally far away from us. Thus we cannot say that the sky is a surface. There is even no way to determine the dimensionality of the horizon, nor the dimensionality of space-time near it.*

Measurements thus do not allow to determine whether the boundary is a point, a surface, or a line. It could be an arbitrary complex shape, even knotted. In fact, quantum theory tells us that it must be all of this from time to time, in short, that *the sky fluctuates in height and shape*.

In short, it is impossible to determine the topology of the sky. But that is nothing new. As is well known, general relativity is unable to describe pair creation of spin 1/2 particles. The reason is the change of space-time topology required by the process. On the other hand, the universe is full of such processes, implying that it is impossible to define a topology for the universe and in particular, to talk of the topology of the horizon itself. Are you able to find at least two other arguments to show this?

Challenge 1053

Worse, quantum theory shows that space-time is not continuous at a horizon, as is easily deduced by applying the Planck scale arguments from the previous section. Time and space are not defined there.

Ref. 1

Finally, there is no way to decide whether the various boundary points are *different* from each other. The distance between two points on the night sky is undefined. In other words, it is unclear what the *diameter* of the horizon is.

In summary, the horizon has no specific distance nor shape. The horizon and thus the universe cannot be shown to be manifolds. This leads to the next question:

Does the universe have initial conditions?

One often reads about the quest for the initial conditions of the universe. But before joining the search, we should ask *whether* and *when* such initial conditions make any sense. Obviously, our everyday description of motion requires them. Initial conditions describe the *state* of a system, i.e. all those aspects which differentiate it from a system with the same intrinsic properties. Initial conditions, like the state of a system, are attributed to a system by an *outside* observer.

Ref. 6

More specifically, quantum theory told us that initial conditions or the state of a system can only be defined by an outside observer with respect to an environment. It is already a difficult feat to be outside the universe. In addition, independently of this issue, even inside

* In addition, the measurement errors imply that no statement can be made about translation symmetry at cosmological scales. Are you able to confirm this? In addition, at the horizon it is impossible to distinguish spacelike and timelike distances. Even worse, concepts such as 'mass' or 'momentum' are muddled up at the horizon. This means that like at Planck energy, we are unable to distinguish between objects and background, and between state and intrinsic properties. We will come back to this important point shortly.

Challenge 1036

the universe a state can only be defined if matter can be distinguished from the vacuum. However, this is impossible at Planck energies, near the big bang, or at the horizon. Thus there is no state for the universe. No state also means *no wavefunction of the universe*.

Ref. 1 The limits imposed by the Planck values also confirm this conclusion in other ways. First of all, they show that the big bang was not a singularity with infinite density or temperature, as infinite large values do not exist in nature. Secondly, since instants of time do not exist, it is impossible to define the state of any system at a given time. Thirdly, as the non-existence of instants of time means that events do not exist, also the big bang was not an event, so that neither an initial state nor an initial wavefunction can be ascribed to the universe also for this more prosaic reason. (Note that this also means that the universe cannot have been created.)

In short, *there are no initial conditions of the universe*. Initial conditions make sense only for subsystems and only far away from Planck scales. That requires that two conditions be fulfilled: the system must be away from the horizon, and it must evolve some time ‘after’ the big bang. Only when these two conditions are fulfilled can objects *move* in space. Of course, this is always the case in everyday life.

At this point of our mountain ascent, where time and length are unclearly defined at cosmological scales, it should come as no surprise that the concept of mass has similar difficulties.

Does the universe contain particles and stars?

See page 822 The number of stars, about $10^{23\pm 1}$, is included in every book on cosmology, as it is in the table of Appendix B. A subset of this number can be counted on clear nights. If we ask the same question about particles instead of stars, the situation is similar. The commonly quoted baryon number is $10^{81\pm 1}$, together with a photon number of $10^{90\pm 1}$.

But this does not settle the issue. Neither quantum theory nor general relativity alone make predictions about the number of particles, neither inside nor outside the horizon. What happens if we combine them?

See page 521 In order to define the number of particles in a region, quantum theory first of all requires a vacuum state. Particle number is defined by comparing the system with the vacuum. Neglecting or leaving out general relativity by assuming flat space-time, this procedure poses no problem. But adding general relativity and thus a curved space-time, especially one with such a strangely behaved horizon as we just found, the answer is simple: there is *no* vacuum state to compare the universe to, for two reasons. First of all, nobody can explain what an empty universe would look like; second, and most importantly, there is no way to define a state of the universe at all. The number of particles in the universe thus becomes undefinable. Only at everyday energies and for finite dimensions are we able to speak of an approximate particle number.

Challenge 1070 Comparison between a system and the vacuum is impossible in the case of the universe also for purely practical reasons. The requirement effectively translates into the requirement that the particle counter be outside the system. (Can you confirm the connection?) In addition, it is impossible to remove particles from the universe. The impossibility to define a vacuum state and thus a particle number for the universe is not surprising. It is an interest-

ing exercise to investigate the measurement errors appearing when we try to determine a particle number despite this fundamental impossibility.

Challenge 1087

Can we count stars? In principle, the same conclusion as for particles applies. However, at everyday energies stars can be counted also *classically*, i.e. without taking them out of the volume they are enclosed in. For example, this is possible by differentiating by their mass, their colour, or any other characteristic, individual property. Only near Planck energy or near the horizon these methods are not applicable. In short, the number of stars is only defined as long as the observation energy is low, i.e. as long as we stay away from Planck energies and from the horizon.

Therefore, despite the appearances at human scales, *there is no definite number of particles in the universe*. The universe cannot be distinguished from vacuum by counting particles. Even though particles are necessary for our own existence and functioning, they cannot be counted completely.

This conclusion is so strange that we cannot accept it too easily. Let us try another method to determine the matter content: instead of counting, let us weigh.

Does the universe contain masses and objects?

The average density of the universe, of about 10^{-26} kg/m³, is frequently cited in texts. Is it different from vacuum? Quantum theory shows that due to the uncertainty relation, even an empty volume of size R has a mass. For a zero energy photon inside it, we have $E/c = \Delta p > \hbar/\Delta x$, so that in a volume of size R , we have a minimum mass of at least $m_{min}(R) = \hbar/cR$. For a spherical volume of radius R there is thus a minimal mass density given roughly by

See page 822

$$\rho_{min} \approx \frac{m_{min}(R)}{R^3} = \frac{\hbar}{cR^4} . \quad (564)$$

For the universe, inserting the standard horizon distance R_0 of twelve thousand million light years, the value becomes about 10^{-142} kg/m³. It describes the density of the vacuum. In other words, the universe, with its density of about 10^{-26} kg/m³, seems to be clearly different from vacuum. But are we sure?

We just deduced that the radius of the horizon is undefined: depending on the observation energy, it can be as small as the Planck length. That implies that the density of the universe lies somewhere between the the lowest possible value, given by the just mentioned vacuum density, and highest possible one, namely the Planck density. * In short, relation (564) does not really provide a clear statement.

Another way to measure the mass of the universe would be to use the original definition of mass, as given by Mach and modified by special relativity, and apply it. Thus, let us try to collide a standard kilogram with the universe. It is not hard to see that whatever we do,

See page 190

Challenge 1104

* In fact, at everyday energies it lies almost exactly between the two values, yielding the strange relation

$$m_0^2/R_0^2 \approx m_{p1}^2/R_{p1}^2 = c^4/G^2 . \quad (565)$$

See page 591

But it is nothing new. The approximate equality can be deduced from the equation 16.4.3 (p. 620) of STEVEN WEINBERG, *Gravitation and Cosmology*, Wiley, 1972, namely $Gn_p m_p = 1/t_0^2$. The relation is required by several cosmological models.

Challenge 1121

using either low or high energies for the standard kilogram, the mass of the universe cannot be constrained by this method. We would need to produce or to measure a velocity change Δv for the rest of the universe after the collision. To hit all mass in the universe at the same time, we need high energy; but then we are hindered by Planck energy effects. In addition, a properly performed collision measurement would require a mass outside the universe, a rather difficult feat.

Still another way to measure the mass would be to determine the gravitational mass of the universe through straightforward weighing. But the lack of balances outside the universe makes this an unpractical solution, to say the least.

A way out might be the most precise definition of mass provided by general relativity, namely the so-called *ADM mass*. However, for its definition a specified behaviour at infinity is required, i.e. a background, which the universe lacks.

See page 265

We are then left with the other general relativistic method: determining the mass of the universe by measuring its average curvature. Let us take the defining expressions for average curvature κ for a region of size R , namely

$$\kappa = \frac{1}{r_{\text{curvature}}^2} = \frac{3}{4\pi} \frac{4\pi R^2 - S}{R^4} = \frac{15}{4\pi} \frac{4\pi R^3/3 - V}{R^5} . \quad (566)$$

Challenge 17

We have to insert the horizon radius R_0 and either its surface S_0 or its volume V_0 . However, given the error margins on the radius and the volume, especially at Planck energies, we again find no reliable result for the radius of curvature.

Ref. 7 An equivalent method starts with the usual expression for the scalar curvature uncertainty $\Delta\kappa$ for a region of size R provided by Rosenfeld, namely

$$\Delta\kappa > \frac{16\pi l_{\text{Pl}}^2}{R^4} . \quad (567)$$

But also this expression shows that the curvature radius error behaves like the horizon distance error.

Challenge 34

In summary, *at Planck energy, the average radius of curvature of nature turns out to lie between infinity and the Planck length*. This implies that the matter density lies between the minimum value and the Planck value. There is thus no method to determine the mass of the universe at Planck energy. (Can you find one?) The concept of mass cannot be applied to the universe as a whole. *The universe has no mass*.

Do symmetries exist in nature?

We have already seen that at the horizon, space-time translation symmetry breaks down. Let us have a quick look at the other symmetries.

What happens to permutation symmetry? Exchange is an operation on objects in space-time. Exchange thus automatically requires a distinction between matter, space, and time. If we cannot distinguish positions, we cannot talk about exchange of particles. But this is exactly what happens at the horizon. In short, general relativity and quantum theory together make it impossible to define permutation symmetry at the horizon.

CPT symmetry suffers the same fate. Due to measurement errors or to limiting maximum or minimum values, it is impossible to distinguish the original from the transformed situation. It is therefore impossible to maintain that CPT is a symmetry of nature at horizon scales. In other words, matter and antimatter cannot be distinguished at the horizon.

The same happens with gauge symmetry, as you might want to check in detail yourself. For its definition, the concept of gauge field requires a distinction between time, space, and mass; at the horizon this is impossible. We deduce that at the horizon also concepts such as algebras of observables cannot be used to describe nature. Also renormalization breaks down.

Challenge 51

All symmetries of nature break down at the horizon. The complete vocabulary we use to talk about observations, such as magnetic field, electric field, potential, spin, charge or speed, cannot be used at the horizon. And that is not all.

Is there a boundary of the universe?

It is common to take ‘boundary’ and ‘horizon’ to be synonyms in the case of the universe, as they are the same for all practical purposes. To study it, knowledge of mathematics does not help us; the properties of mathematical boundaries, e.g. that they themselves have no boundary, are not applicable in the case of nature, since space-time is not continuous. We need other, physical arguments.

The boundary of the universe is obviously supposed to mean the boundary between *something* and *nothing*. This gives three possibilities:

- ‘Nothing’ could mean ‘no matter’. But we just saw that this distinction cannot be made at Planck scales. As a consequence, the boundary would either not exist at all or encompass both the horizon *as well as* the whole universe.
- ‘Nothing’ could mean ‘no space-time’. We then have to look for those domains where space and time cease to exist. That happens at Planck scales and at the horizon. Again, the boundary would either not exist or encompass the whole universe.
- ‘Nothing’ could mean ‘neither space-time nor matter.’ The only possibility is a boundary to domains *beyond* the Planck scale and *beyond* the horizon. But such a boundary would also encompass all of nature.

This result is puzzling. When combining quantum theory and relativity, we do not seem to be able to find a conceptual definition of the horizon which distinguishes it from its interior. In fact, if you find one, publish it! A distinction *is* possible in general relativity; a distinction also possible in quantum theory. But as soon as we combine the two, the boundary becomes indistinguishable from its content. *The interior of the universe cannot be distinguished from its horizon.* There is no boundary.

Challenge 68

That is definitely interesting; it suggests that nature might be *symmetric* under transformations which exchange interiors and boundaries. This connection is nowadays called *holography* because it vaguely recalls the working of credit card holograms. It is an busy research field in present high energy physics. However, for the time being we continue with our original theme, which directly leads us to ask:

Ref. 8

Is the universe a set?

We are used to call the universe the sum of all matter and all space-time. In other words, we implied that the universe is a list of components, all different from each other. This idea was introduced in three situations: it was assumed that matter consists of particles, that space-time consists of events (or points), and that the set of states consists of different initial conditions. But our discussion so far shows that the universe is *not* a list of such distinguishable elements. We encountered several proofs: at the horizon, at the big bang and at Planck scales distinction between events, between particles, between observables, and between space-time and matter becomes impossible. In those domains, distinctions of any kind become impossible. We found that any distinction among two entities, such as between a tooth brush and a mountain, is possible only *approximately*. The approximation is possible because we live at energies much smaller than the Planck energy. Obviously, we are able to distinguish cars from people and from toothpicks; the approximation is so good that we do not notice the error when performing it. But the discussion of the situation at Planck energies shows that a perfect distinction is impossible in principle. *It is impossible to split the universe into separate entities.*

Another way to reach this result is the following. Distinction of two entities requires different measurement results, such as different positions, masses, sizes, etc. Whatever quantity we choose, at Planck energies the distinction becomes impossible. Only at everyday energies it is approximately possible.

See page 460 In short, since the universe is not a list of entities, *the universe is not a set*. We envisaged this possibility already in the first intermezzo; now it is confirmed. The concept of ‘set’ is already too specialized to describe the universe. *The universe must be described by a mathematical concept which does not contain any set.*

This is a powerful result: it means that the universe cannot be described precisely if any of the concepts used for its description presuppose sets. But all concepts we used so far to describe nature, such as space-time, phase space, Hilbert-space and its generalizations, Fock space or particle space, are based on sets. They all must be abandoned at Planck energy, and thus also in any precise description.*

Challenge 102 Also many speculations about unified descriptions do not satisfy the criterion of eliminating sets. In particular, all studies of quantum fluctuations, mathematical categories, posets, complex mathematical spaces, computer programs, Turing machines, Gödel’s theorem, creation of any sort, space-time lattices, quantum lattices or Bohm’s unbroken wholeness fail to satisfy the requirement. In addition, almost all speculations about the origin of the universe cannot be correct. For example, you might want to check the religious explanations you know against this result. In fact, no approach of theoretical physics in the year 2000 satisfies the requirement to abandon sets; maybe a future version of string or M theory might do so.

Note that this radical conclusion is deduced from only two statements: the necessity of using quantum theory whenever the dimensions are of the order of the Compton wavelength, and the necessity to use general relativity whenever the dimensions are of the order of the Schwarzschild radius. Together, they mean that any precise description of nature cannot contain sets. We reached this result after a long and interesting, but in a sense unnecessary

Challenge 85 * Do you know a concept not based on a set?

digression. The difficulties to comply with this result may explain why the unification of the two theories was not successful so far. Not only does unification require that we stop using space, time and mass for the description of nature; it also requires that all distinctions, of any kind, be only approximate. But all physicists have been educated with exactly the opposite credo!

Note that failing to be a set, *the universe is not a physical system*. In particular, it has no state, no intrinsic properties, no wavefunction, no initial conditions, no density, no entropy and no cosmological constant. Neither is it thermodynamically closed or open, nor does it contain any information. All thermodynamical quantities, such as entropy, temperature or free energy, are defined using *ensembles*. Ensembles are limits of systems, either thermodynamically open or closed ones. The universe being neither of the two, no thermodynamic quantity can be defined for it. * All physical properties are only defined for parts of nature which are approximated or idealized as sets, and thus are physical systems. The universe is neither.

Hilbert's sixth problem settled

In the year 1900, David Hilbert gave a famous lecture in which he listed 23 of the great challenges facing mathematics in the twentieth century. Most problems provided challenges to many mathematicians for decades afterwards. A few are still unsolved, among them the sixth. The sixth problem was challenged mathematicians and physicists to find an *axiomatic* treatment of physics.

See page 439
Ref. 9

Since the universe is not even a set, we can deduce that such an axiomatic description of nature is *impossible*. The reasoning is simple; all mathematical systems, be they algebraic systems, order systems, or topological systems, are based on sets. Mathematics does not have axiomatic systems which do not contain sets. The reason is that every contains at least one set.

The impossibility of an axiomatic system for physics is also confirmed in another way. Physics starts with a *circular* definition: space-time is defined with help of objects and objects are defined with help of space-time. Physics thus has *never* been modelled after mathematics. Physicists always had to live with logical problems.

See page 111

The situation is similar to the description of the sky by a child as 'made of air and clouds'. Looking closely, we discover that clouds are made of water droplets. But there is air inside clouds, and there is also water vapour elsewhere in air. When clouds and air are watched through the microscope, there is no clear boundary between the two. We cannot define any of the terms 'cloud' and 'air' without the other. No axiomatic definition is possible.

Objects and vacuum also behave in this way. Virtual particles are found in the vacuum, and vacuum is found inside objects. At Planck scales, there is no clear boundary between the two; we cannot either of them without the other. In both cases, despite the lack of precise definition and despite the logical problems ensuing, the description works well at large, everyday scales.

But then a question arises naturally:

* There are people who knew this long before physicists; for example, the belief that the universe is or contains information was ridiculed most thoroughly in the popular science fiction parody DOUGLAS ADAMS, *The Hitchhiker's Guide to the Galaxy*, 1979, and its sequels.

Does the universe make sense?

Drum hab ich mich der Magie ergeben,
 [...]

 Daß ich erkenne, was die Welt
 Im Innersten zusammenhält.*
 Goethe, *Faust*.

Is the universe really the sum of matter-energy and space-time? Or of particles and vacuum? We heard this so often up to now that we might be lulled into forgetting to check the statement. To find out, we do not need magic, as Faust thought; we only need to list what we found in this section, in the section on Planck scales, and in the intermezzo on brain and language. Table 50 shows the result.

See page 414

Table 50 Physical properties of the universe

- The universe has no age.
- The universe has no size.
- The universe has no shape.
- The universe has no mass.
- The universe has no density.
- The universe has no cosmological constant.
- The universe has no state.
- The universe is not a physical system.
- The universe is not isolated.
- The universe has no boundaries.
- The universe cannot be measured.
- The universe cannot be distinguished from nothing.
- The universe contains moments.
- The universe is not a set.
- The universe cannot be described.
- The universe cannot be distinguished from vacuum.
- The universe has no beginning.
- The universe has no volume.
- The universe has no particle number.
- The universe has no energy.
- The universe contains no matter.
- The universe has no initial conditions.
- The universe has no wave function.
- The universe contains no information.
- The universe is not open.
- The universe does not interact.
- The universe cannot be said to exist.
- The universe cannot be distinguished from a single event.
- The universe is not composite.
- The universe is not a concept.
- There is no plural for ‘universe’.
- The universe was not created.

Not only are we unable to state that the universe is made of space-time and matter; in fact, we are unable to say anything positive about the universe at all!** It is not even possible to say that it exists, since it is impossible to interact with it. The term ‘universe’ does not allow to make a single sensible statement. (Can you find one?) We are only able to say which properties it does *not* have. We are unable to find any property the universe *does* have. The universe has no properties! We cannot even say whether the universe is something or nothing. *The universe isn’t anything in particular.* In other words, the term ‘universe’ is not useful at all for the description of motion.

Challenge 136

See page 427

We get a confirmation for this strange conclusion from the first intermezzo. There we found that any concept needs a defined content, defined limits, and a defined domain of application. In this section, we found that for the term ‘universe’, neither of these aspects is

* Thus I have devoted myself to magic, [...] that I understand how the innermost of the world is held together.

** There is also a well-known non-physical concept of which nothing positive can be said. Man scholars have explored it in detail. Can you spot it?

Challenge 119

defined; there is thus *no* such concept. If somebody asks: ‘why does the universe exist?’ the answer is: not only does the use of ‘why’ wrongly suggest that something might exist outside the universe, providing a reason for it, and thus contradicting the definition of the term ‘universe’ itself; most importantly of all, the universe simply does not exist. Any sentence containing the word universe makes no sense. The term ‘universe’ only *seems* to express something, but it doesn’t. We will therefore avoid using it from now on.*

This conclusion may be interesting, even strangely beautiful; but does it help us to understand motion more precisely? Interestingly so, it does.

Extremal scales and open questions of physics

In the chapter *Quantum physics in a nutshell* we had listed all the unexplained properties of nature left open either by general relativity or quantum theory. The present conclusions provide a new connection among them. Indeed, many of the cosmological results of this section sound surprisingly familiar; let us compare them systematically with those of the section on Planck scales. Both sections explored topics – some in more details than others – from the list of unexplained properties of nature.

See page 653

Table 51 Properties of nature at maximal, everyday and minimal scales

Physical property of nature	at horizon scale	at everyday scale	at Planck scale
requires quantum theory and relativity	true	wrong	true
intervals can be measured precisely	wrong	true	wrong
length and time intervals are	limited	unlimited	limited
space-time is not continuous	true	wrong	true
points and events cannot be distinguished	true	wrong	true
space-time is not a manifold	true	wrong	true
space is 3 dimensional	wrong	true	wrong
space and time are indistinguishable	true	wrong	true
initial conditions make sense	wrong	true	wrong
space-time fluctuates	true	wrong	true
Lorentz and Poincaré symmetry	disappear	correct	disappear
CPT symmetry	disappears	correct	disappears
renormalization	does not work	works	does not work
permutation symmetry	disappears	correct	disappears
interactions	disappear	exist	disappear
number of particles	undefined	defined	undefined
algebras of observables	disappear	apply	disappear
matter indistinguishable from vacuum	true	wrong	true
boundaries exist	wrong	true	wrong
nature is a set	wrong	true	wrong

First of all, Table 51 shows that *each* of the unexplained properties makes no sense at *both* limits of nature, the small *and* the large. All open questions are open at both extremes.

* Of course, the term ‘universe’ still makes sense if it is defined more restrictively, such as ‘everything interacting with a particular human or animal observer in everyday life.’ But such a definition is not useful for our quest, as it lacks the precision required for any description of motion.

Challenge 153 Secondly and more importantly, nature behaves in the same way at horizon scales and at Planck scales. In fact, we have not found any difference between the two cases. Are you able to discover one? * We are thus lead to the hypothesis that nature does not distinguish between the large and the small. Nature seems to be characterized by *extremal identity*.

Is extremal identity a principle of nature?

The principle of extremal identity incorporates some rather general points:

- all open questions about nature so far appear at its two extremes;
- a description of nature requires both general relativity and quantum theory;
- nature is not a set;
- initial conditions and evolution equations make no sense at nature's limits;
- there is a relation between local and global issues in nature;
- the concept of 'universe' makes no sense.

Challenge 170 Extremal identity thus looks like a good candidate tool in the search for a unified description of nature. To be a bit more provocative, it might be the *only* known principle incorporating the idea that the universe is not a set, and thus might be the only candidate for the quest of unification. Extremal identity is beautiful in its simplicity, its unexpectedness and its richness of consequences. Just explore it a little for yourself.

Ref. 10 The consequences of extremal identity are presently studied with great intensity in high energy particle physics, though often under different names. The simplest approach to extremal identity – in fact too simple to be correct – is inversion. It looks as if extremal identity implies a connection such as

$$r \leftrightarrow \frac{l_{\text{Pl}}^2}{r} \quad \text{or} \quad x_\mu \leftrightarrow \frac{l_{\text{Pl}}^2 x_\mu}{x_\mu x^\mu} . \quad (568)$$

Challenge 187 Could this mapping, called *inversion*, be a symmetry of nature? At every point of space? For example, inserting the horizon distance, equation (568) would imply that lengths smaller than $l_{\text{Pl}}/10^{61} \approx 10^{-96}$ m never appear in physics. Is this the case? What would inversion imply for the big bang?

Numerous fascinating questions are contained in the simple hypothesis of extremal identity. They lead to *two* main directions of investigation.

We have to start by searching for some stronger arguments for the validity of extremal identity. We will discover a number of simple arguments, all showing that extremal identity is indeed a property of nature, and producing many beautiful insights.

Challenge 204 The other quest then follows. We need to find the correct version of equation (568). That oversimplified expression is neither sufficient nor correct. It is not sufficient because it does not explain *any* of the issues left open by general relativity and quantum theory. It only *relates* some of them, thus reducing their number, but doesn't *solve* any of them. You might want to check this for yourself.

But inversion is also simply wrong. Inversion is not the correct description of extremal identity because it does not realize a central result discovered above: it does not connect *states* and *intrinsic properties*. Inversion keeps them distinct. Among others, this means

* If so, send a message to cs@motionmountain.org; but first of all, publish it!

that inversion does not take into account *interactions*. And most open issues in at this point of our mountain ascent are properties of interactions.

References

- 1 Available at <http://www.dse.nl/motionmountain/contents.html>. Those pages are a reworked version of the ones published in French as C. SCHILLER, *Le vide diffère-t-il de la matière?*, in E. GUNZIG & S. DINER, éditeurs, *Le vide – Univers du tout et du rien – Des physiciens et des philosophes s’interrogent*, Les Éditions de l’Université de Bruxelles, 1998. An older English version is also available as CHRISTOPH SCHILLER, *Does matter differ from vacuum?*, <http://xxx.lanl.gov/abs/gr-qc/9610066>. Cited on page 700, 704, 710, 711.
- 2 See the lucid discussion by G.F.R. ELLIS & T. ROTHMAN, *Lost horizons*, American Journal of Physics **61**, pp. 883–893, 1993. Cited on page 702, 707, 708, 708, 708.
- 3 H. SALECKER & E.P. WIGNER, *Quantum limitations of the measurement of space-time distances*, Physical Review **109**, pp. 571–577, 1958. See also the popular account of this paper by E.J. ZIMMERMAN, *The macroscopic nature of space-time*, American Journal of Physics **30**, pp. 97–105, 1962. Cited on page 702.
- 4 Y.J. NG & H. VAN DAM, *Limit to space-time measurement*, Modern Physics Letters A **9**, pp. 335–340, 1994, Y.J. NG & H. VAN DAM, *Modern Physics Letters A Remarks on gravitational sources*, **10**, pp. 2801–2808, 1995. Cited on page 702.
- 5 See e.g. the movie *Contact*, based on the book by CARL SAGAN, *Contact*, 1996. Cited on page 708.
- 6 For example the international bestseller by S. HAWKING, *A Brief History of Time – From the Big Bang to Black Holes*, 1988. Cited on page 710.
- 7 L. ROSENFELD, in H.-J. TREDER, *Entstehung, Entwicklung und Perspektiven der Einsteinschen Gravitationstheorie*, Springer Verlag, 1966. Cited on page 713.
- 8 Holography is connected with the work by ’t Hooft and Susskind. See for example G. ’T HOOFT, *Dimensional reduction in quantum gravity*, pp. 284–296, in A. ALI, J. ELLIS & S. RANDJBAR-DAEMI, *Salaamfeest*, 1993, or also the paper by L. SUSSKIND, *Journal of Mathematical Physics* **36**, p. 6377, 1995. Cited on page 714.
- 9 See for example *Die Hilbertschen Probleme*, Akademische Verlagsgesellschaft Geest & Portig, 1983, or BEN H. YANDELL, *The Honours Class: Hilbert’s Problems and their Solvers*, ... 2002. Cited on page 716.
- 10 Large part of the study of dualities in string and M theory can be seen as investigations into the detailed consequences of extremal identity. For a review, see ... Cited on page 719.
A classical version of duality is discussed by M.C.B. ABDDALLA, A.L. GADELKA & I.V. VANCEA, *Duality between coordinates and the Dirac field*, hep-th/0002217.



33. The physics of sex – a summary of the first two and a half parts

Sex is the physics urge sublimated.
Graffito

Maybe you have once met a physicist who has told you, in one of those Moments of confidentiality, that studying physics is more beautiful than making love. At this statement, many will simply shake their head in disbelief, and strongly disapprove. In this section we will argue that it is possible to learn so much about physics while making love that discussions about their relative beauty can be put aside altogether.

Typeset in
July 2002

Imagine to be with your partner on a beautiful tropical island, just after sunset, and to look together at the evening sky. Imagine as well that you know little of what is taught at school nowadays, e.g. that your knowledge is that of the late renaissance, which probably is a good description of the average modern education level anyway.

Imagine being busy enjoying each other's company. then most important results of physics can be deduced from the following experimental facts: *

Sex is communication.	Sex is tiring.
Sex is an interaction between moving bodies.	Sex takes time.
Sex is attractive.	Sex is repulsive.
Sex makes noise.	In sex, size matters.
Sex is for reproduction.	Sex can hurt.
Sex needs memory.	Sex is Greek.
Sex uses the sense of sight.	Sex is animalic.
Sex is motion.	Sex is holy.
Sex is based on touch.	Sex uses motion again.
Sex is fun.	Sex is private.
Sex makes one dream.	

Let us see why.

- Sex is *communication*. Communication is possible because nature looks similar from different standpoints and because nature shows no surprises. Without similarity we could not understand each other, and a world of surprises would even make thinking impossible; it would not be possible to form concepts to describe observations. But fortunately, the world is regular; it thus allows to use concepts such as time and space for its description.

- Sex is an *interaction between moving bodies*. Together with the previous result, this implies that we can and need to describe moving bodies with *mass*, *energy* and *momentum*. That is not a small feat. For example, it implies that the sun will rise tomorrow if the sea level around the island is the usual one.

- Sex is *attractive*. When feeling attracted to your partner, you may wonder if this attraction is the same which keeps the moon going around the earth. You make a quick calculation,

Challenge 221

Ref. 1 * In fact, studying the influences of *sex* on physics is mostly a waste of time. We avoid it. True, maybe one day we will understand why there do not seem to be any female crackpots proposing pet physical theories. Much more fun is the influence of *sexuality* onto physics, as shown in this section. In the following, we thus bow to the modern habit of saying 'sex' instead of 'sexuality'.

and find that applying the expression for universal gravity

$$E_{\text{pot}} = -\frac{GMm}{r} \quad (569)$$

to both of you, the involved energy is about as much as the energy added by the leg of a fly on the skin. In short, your partner teaches you that in nature there are other attractive interactions apart from gravity; the average modern education is incomplete.

Nevertheless, this first equation is important: it allows to predict the position of the planets, the time of the tides, the time of eclipses, the return of comets, etc., to a high accuracy for thousands of years in advance.

- *Sex makes noise.* That is no news. However, even after sex, even when everybody and everything is quiet, in a completely silent environment, we do hear something. The noises we hear are produced within the ear, partly by the blood flowing through the head, partly by the electrical noise generated in the nerves. That is strange. If matter were continuous, there would be no noise even for low signal levels. In fact, all proofs for the discreteness of matter, of electric current, of energy, or of light are based on the increase of fluctuations with the smallness of systems under consideration. The persistence of noise thus makes us suspect that matter is made of smallest entities. Making love confirms this suspicion in several ways.

- *Sex is for reproduction.* Sex is what we owe our life to, as we all are results of reproduction. But the reproduction of a structure is possible only if it can be constructed, in other words if the structure can be built from small standard entities. Thus we again suspect ourselves to be made of smallest, discrete entities.

Sex is also a complicated method of reproduction. Mathematics provides a much simpler one. If matter objects were not made of particles, but were continuous, it would be possible to perform reproduction by cutting and reassembling. A famous mathematical theorem by Banach and Tarski proves that it is possible to take a continuous solid, cut it into six pieces, and rearrange the pieces in such a way that the result are *two* copies of the same size and volume as the original. In fact, even volume increases can be produced in this way, thus realizing growth without any need for food. Mathematics thus provides some interesting methods for growth and reproduction. However, they assume that matter is continuous, without a smallest length scale. The observation that these methods do not work in nature is compatible with the idea that matter is not continuous.

- *Sex needs memory.* If you would not recognize your partner among all possible ones, your love life would be quite complicated. A memory is a device which, in order to store information, must have small internal fluctuations. Obviously, fluctuations in systems get smaller as their number of components increase. Since our memory works so well, we can follow that we are made of a large number of small particles.

Ref. 2

In summary, sex shows that we are made of some kind of lego bricks: depending on the level of magnification, these bricks are called molecules, atoms, or elementary particles. It is possible to estimate their size using the sea around the tropical island, as well as a bit of oil. Can you imagine how?

Challenge 255

- *Sex uses the sense of sight.* Seeing each other is only possible because we are cold whereas the sun is hot. If we and our environment all had the same temperature as the sun, we would not see each other. This can be checked experimentally by looking into a hot

This is a section of the freely downloadable e-textbook

Motion Mountain

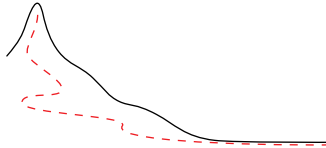

Hiking beyond space and time along the concepts of modern physics

available at
www.motionmountain.org

Copyright © 1997, 1998, 1999, 2000, 2001, 2002 by Christoph Schiller

To the kind reader

In exchange for getting this section for free, I ask you for a short email on some of the following:

- Which page was boring?
- Did you find any mistakes?
- What else were you expecting?
- What was hard to understand?

Of course, any other suggestion is welcome. This section is part of a physics text written over many years. The text lives and grows through the feedback from its readers, who help to improve and to complete it. For a particularly useful contribution (send it in english, italian, dutch, german, spanish, portuguese, or french) you will be mentioned in the foreword of the text, or receive a small reward, or both.

Enjoy!

Christoph Schiller
cs@motionmountain.org

Challenge 238

oven: Inside a glowing oven filled with glowing objects it is impossible to discern them against the background. Ref. 3

- *Sex is motion.* Bodies move against each other. Moreover, their speed can be measured. Since measurement is a comparison with a standard, there must be a velocity standard in nature, some special velocity standing out. Such a standard must either be the minimum or the maximum possible value. Now, daily life shows that for velocity, a minimum value does not exist. We are thus looking for a maximum value. To estimate the value of the maximum, just take your cellular phone and ring home from the island to your family. From the delay in the line and the height of the satellite, you can deduce the telephone speed c .

The existence of a maximum speed c implies that time is different for different observers. Looking into the details, we find that this effect becomes noticeable at energies

$$E_{\text{different time}} \approx mc^2 \quad . \quad (570)$$

For example, this applies to electrons inside a television tube.

- *Sex is based on touching.* When we touch our partner, sometimes we get small shocks. The energies involved are larger than those of touching fly legs. In short, people are electric.

In the dark, we observe that discharges emit light. Light is thus related to electricity. In addition, touching proves that light is a wave: simply observe the dark lines between two fingers near your eye in front of a bright background. The lines are due to interference effects. Light thus does not move with infinite speed. In fact, it moves with the same speed as that of telephone calls. Challenge 272

- *Sex is fun.* People like to make love in different ways, such as in a dark room. But rooms get dark when the light is switched off only because we live in a space of odd dimensions. In even dimensions, a lamp would not turn off directly after the switch is flipped, but dim only slowly.

Sex is also fun because with our legs, arms, and bodies we can make knots. Knots are possible only in three dimensions. In short, sex is real fun only because we live in 3 dimensions.

- *Sex is tiring.* The reason is gravity. But what is gravity? A little thinking shows that since there is a maximum speed, gravity is the curvature of space-time. Curved space also means that a *horizon* can appear, i.e. a largest possible visible distance. From equations (569) and (570), we deduce that this happens when distances are of the order of

$$R_{\text{horizon}} \approx Gm/c^2 \quad . \quad (571)$$

For example, only due to a horizon, albeit one appearing in a different way, the night sky is dark.

- *Sex takes time.* It is known that men and women have different opinions on durations. It is also known that sex happens between your ears. Indeed, biological research has shown that we have a clock inside the brain, due to circulating electrical currents. This clock provides our normal sense of time. Since such a brain clock can be built, there must be a time standard in nature. Again, such a standard must be either a minimum or a maximum time interval. We will discover it later on. Ref. 7

▪ Sex is *repulsive*. And in sex, *size matters*. Both facts turn out to be the two sides of the same coin. Sex is based on touch, and touch needs repulsion. Repulsion needs a length scale, but neither gravity nor classical electrodynamics provide one. Classical physics only allows for the measurement of speed. Classical physics cannot explain that the measurement of length, time, or mass is possible.* Classically, matter cannot be hard; it should be possible to compress it. But sex shows us that this is not the case. Sex shows us that lengths scales do exist in nature, and thus that classical physics is not sufficient for the description of nature.

▪ Sex can *hurt*. For example, it can lead to injuries. Atoms can get ripped apart. That happens when energies are concentrated on small volumes, such as a few aJ per atom. Investigating such situations more precisely, we finds that strange phenomena appear at distances r if energies exceed the value

$$E \approx \frac{\hbar c}{r} \quad ; \quad (572)$$

in particular, energy becomes chunky, things become fuzzy, boxes are no tight, and particles get be confused. These are called *quantum* phenomena. The new constant \hbar is important: it determines the size of things, because it allows to define distance and time units. In other words, objects tear and break because in nature there is a minimum action, given roughly by \hbar .

If even more energy is concentrated in small volumes, such as energies of the order of mc^2 per particle, one even observes transformation of energy into matter, or *pair production*. From equations (570) and (572), we deduce that this happens at distances of

$$r_{\text{pair production}} \approx \frac{\hbar}{m c} \quad . \quad (573)$$

At such small distances we cannot avoid using the quantum description of nature.

▪ Sex is not only *Greek*. The Greek were the first to make theories above love, such as Plato in his *Phaedrus*. But they also described it in another way. Already before Plato, Democritus said that making love is an example of particles moving and interacting in vacuum. If we change ‘vacuum’ to ‘curved 3+1-dimensional space’, and particle to ‘quantum particle’, we do indeed make love in the way Democritus described 2500 years ago.

It seems that physics has not made much progress in the mean time. Take the statement made in 1939 by the British astrophysicist Arthur Eddington:

Ref. 4 I believe there are 15,747,724,136,275,002,577,605,653,961,181,555,468,044,717,914,527,
116,709,366,231,425,076,185,631,031,296 protons in the universe and the same number of
electrons.

Compare it with the version of 2002:

Baryons in the universe: $10^{81 \pm 1}$; total charge: near zero.

The second is more honest, but which of the two is less sensible? Both sentences show that there are unexplained facts in the Greek description nature, in particular the number of involved particles.

* Note that the classical electron radius is not an exception: it contains the elementary charge e , which contains a length scale, as shown on page 311.

▪ Sex is *animalic*. We have seen that we can learn a lot about nature from the existence of sex. We could be tempted to see this approach of nature as a special case of the so-called *anthropic principle*. However, some care is required here. In fact, we could have learned exactly the same if we had taken as starting point the observation that *apes* or *pigs* have sex. There is no ‘law’ of nature which distinguishes between them and humans. In fact, there is a simple way to determine whether any ‘anthropic’ statement makes sense: the reasoning must be equally true for humans, apes, and pigs.

A famous anthropic statement was made by the British astrophysicist Fred Hoyle. While studying stars, he predicted a resonance in the carbon-12 nucleus. If it did not exist, he argued, stars could not have produced the carbon which afterwards was spread out by explosions into interstellar space and collected on earth. Also apes or pigs could reason this way; therefore Hoyle’s statement does make sense.

On the other hand, claiming that the universe is made *especially* for people is not sensible: using the same arguments, pigs would say it is made for pigs. The existence of either requires all ‘laws’ of nature. In summary, the anthropic principle is true only in so far as its consequences are indistinguishable from the porcine or the simian principle. In short, the animalic side of sex puts limits to the philosophy of physics.

▪ Sex is *holy*. Following the famous definition by the theologian Rudolf Otto, holiness results from a mixture of a *mysterium tremendum* and a *mysterium fascinans*. Tremendum means that it makes one tremble. Indeed, sex produces heat and is a dissipative process. All systems in nature which produce heat have a finite lifetime. That is true for machines, stars, animals, lightning, fire, lamps, and people. Through heat, sex shows us that we are going to die. Physicists call this the second principle of thermodynamics.

Ref. 5

But sex also fascinates. Everything which fascinates has a story. Indeed, this is a principle of nature: every dissipative structure, every structure which appears or is sustained through the release of energy, tells us that it has a story. Take atoms, for example. All the protons we are made of formed during the big bang. Most hydrogen we are made of is also that old. The other elements were formed in stars, and then blown into the sky during nova or supernova explosions. They then regrouped during planet formation. We truly are made of stardust.

Why do such stories fascinate? If you only think about how you and your partner have met, you will discover that it is through a chain of incredible coincidences. If only one of all these coincidences had not taken place, you and your partner would not be together. And of course, we all owe our existence to such a chain of coincidences, which brought our parents together, our grandparents, and made life appear on earth.

The realization of the importance of coincidences automatically produces two kinds of questions: *why?* and *what if?* Physicists have now produced a list of all the answers to repeated why questions, and many are working at the list of what-if questions. The first list, the why-list of Table 53, gives all facts still unexplained. It can also be called the complete list of all surprises in nature. (Above, it was said that there are no surprises in nature about *what* happens. However, so far there still are a handful of surprises on *how* all these things happen.)

Table 53 *Everything* quantum field theory and general relativity do *not* explain; in other words, a list of *the only* experimental data and criteria available for tests of the unified description of motion.

Observed value	Property unexplained so far
Local quantities, from quantum theory	
α_{em}	the low energy value of the electromagnetic coupling constant
α_w	the low energy value of the weak coupling constant
α_s	the low energy value of the strong coupling constant
m_q	the values of the 6 quark masses
m_l	the values of 3 lepton masses
m_W	the values of the independent mass of the W vector boson
θ_W	the value of the Weinberg angle
$\beta_1, \beta_2, \beta_3$	three mixing angles
θ_{CP}	the value of the CP parameter
θ_{st}	the value of the strong topological angle
3	the number of particle generations
0.5 nJ/m^3	the value of the observed vacuum energy density or cosmological constant
$3 + 1$	the number of space and time dimensions
Global quantities, from general relativity	
$1.2(1) \cdot 10^{26} \text{ m} ?$	the distance of the horizon, i.e. the ‘size’ of the universe (if it makes sense)
$10^{82} ?$	the number of baryons in the universe, i.e. the average matter density in the universe (if it makes sense)
$> 10^{92} ?$	the initial conditions for more than 10^{92} particle fields in the universe, including those at the origin of galaxies and stars (if they make sense)
Local structures, from quantum theory	
$S(n)$	the origin of particle identity, i.e. of permutation symmetry
Ren. group	the renormalisation properties, i.e. the existence of point particles
$SO(3,1)$	the origin of Lorentz (or Poincaré) symmetry (i.e. of spin, position, energy, momentum)
C^*	the origin of the algebra of observables
Gauge group	the origin of gauge symmetry (and thus of charge, strangeness, beauty, etc.)
in particular, for the standard model:	
$U(1)$	the origin of the electromagnetic gauge group (i.e. of the quantization of electric charge, as well as the vanishing of magnetic charge)
$SU(2)$	the origin of weak interaction gauge group
$SU(3)$	the origin of strong interaction gauge group
Global structures, from general relativity	
maybe $\mathbb{R} \times S^3?$	the unknown topology of the universe (if it makes sense)

This why-list fascinates through its shortness, which many researchers are still trying to reduce. But it is equally interesting to study what consequences appear if any of the values from Table 53 were only a tiny bit different. It is not a secret that small changes in nature would lead to completely different observations, as shown in Table 54.

Table 54 A tiny selection of the consequences of changing aspect of nature

Observable	Change	Result
Moon size	smaller	small earth magnetic field; too much cosmic radiation; widespread child cancers.
Moon size	larger	large earth magnetic field; too little cosmic radiation; no evolution into humans.
Jupiter	smaller	too many comet impacts on earth; extinction of animal life.
Jupiter	larger	too little comet impacts on earth; no moon; no dinosaur extinction.
Oort belt	smaller	no comets, no irregular asteroids, no moon; still dinosaurs.
Galaxy distance	smaller	irregular planet motion; supernova dangers.
Strong coupling constant	smaller	proton decay; leukemia.

The large number of coincidences of life force our mind to realize that we are only a *tiny* part of nature. We are a small droplet shaken around in the ocean of nature. Even the tiniest changes in nature would prevent the existence of humans, apes, and pigs. In other words, making love tells us that the universe is much larger than we are, and tells us how much we are dependent and connected to the rest of the universe.

▪ We said above that sex uses *motion*. It contains a remarkable mystery, worth a second look:

- Motion is the change of position with time of some bodies.
- Position is what we measure with a ruler. Time is what we measure with a clock. Both rulers and clocks are bodies.
- A body is an entity distinct from its environment by its shape or its mass. Shape is the extension of a body in space (and time). Mass is measured by measuring speed or acceleration, i.e. by measuring space and time.

This means that we define space-time with bodies – as done in detail in general relativity – and that we define bodies with space-time – as done in detail in quantum theory. This circular reasoning shows that making love is truly a mystery. The circular reasoning has not yet been eliminated yet; at present, modern theoretical physicists are busy attempting to do so. The most promising approach seems to be M-theory, the modern extension of string theory. But any such attempt has to overcome important difficulties which can also be experienced while making love.

▪ Sex is *private*. But is it? Privacy assumes that a person can separate itself from the rest, without important interactions, at least for a given time, and come back later. This is possible if the person puts enough *empty space* between itself and others. In other words, privacy is based on the idea that objects can be distinguished from vacuum. Let us check whether this is always possible.

What is the smallest measurable distance? This question has been almost, but only almost answered by Max Planck in 1899. The distance δl between two objects of mass m is surely larger than their position uncertainty $\hbar/\Delta p$; and the momentum uncertainty must be smaller

Ref. 6

that the momentum leading to pair production, i.e. $\Delta p < mc$. This means that

$$\delta l \geq \Delta l \geq \frac{\hbar}{mc} . \tag{574}$$

In addition, the measurements require that signals leave the objects; the two masses must not be black holes. Their masses must be so small that the Schwarzschild radius is smaller than the distance to be measured. This means that $r_s \approx Gm/c^2 < \delta l$ or that

$$\delta l \geq \sqrt{\frac{\hbar G}{c^3}} = l_{Pl} = 1.6 \cdot 10^{-35} \text{ m} . \tag{575}$$

This expression defines a minimum length in nature, the so-called *Planck length*. Every other Gedankenexperiment leads to this characteristic length as well. In fact, this minimum distance (and the corresponding minimum time interval) provides the measurement standard we were looking for at the beginning of our musings about length and time measurements.

A more detailed discussion shows that the smallest *measurable* distance is somewhat larger, a multiple of the Planck length, as measurements require the distinction of matter and radiation. This happens at scales about 800 times the Planck length.

In other words, privacy has its limits. In fact, the issue is even more muddled when we explore the consequences for bodies. A body, also a human one, is something we can touch, throw, hit, carry or weigh. Physicists say that a body is something with energy or momentum. Vacuum has none of it. In addition, vacuum is unbounded, whereas objects are bounded.

What happens if we try to weigh objects at Planck scales? Quantum theory makes a simple prediction. If we put an object of mass M in a box of size R onto a scale, equation (572) implies that there is a minimal mass error ΔM given by

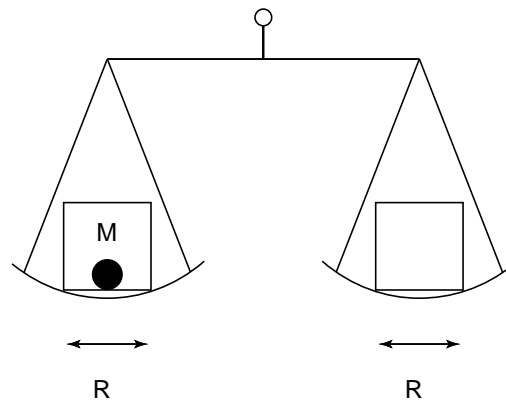

Figure 234 A *Gedankenexperiment* showing that at Planck scales, matter and vacuum cannot be distinguished

$$\Delta M \approx \frac{\hbar}{cR} . \tag{576}$$

If the box has Planck size, the mass error is the Planck mass

$$\Delta M = M_{Pl} = \sqrt{\hbar c/G} \approx 22 \mu\text{g} . \tag{577}$$

How large is the mass we can put into a box of Planck size? Obviously it is given by the maximum possible mass density. To determine it, imagine a planet and put a satellite in orbit around it, just skimming its surface. The density ρ of the planet with radius r is given by

$$\rho \approx \frac{M}{r^3} = \frac{v^2}{Gr^2} . \tag{578}$$

Using equation (574) we find that the maximum mass density in nature, within a factor of order one, is the so-called *Planck density*, given by

$$\rho_{\text{Pl}} = \frac{c^5}{G^2 \hbar} = 5.2 \cdot 10^{96} \text{ kg/m}^3 \quad . \quad (579)$$

Therefore the *maximum* mass that can be contained inside a Planck box is the Planck mass. But that was also the measurement *error* for that situation. This implies that we cannot say whether the original box we measured was empty or full: vacuum *cannot* be distinguished from matter at Planck scales. This astonishing result is confirmed by every other Gedankenexperiment exploring the issue.

Ref. 6

It is straightforward to deduce with similar arguments that objects are not bound in size at Planck scales, i.e. that they are not localized, and that the vacuum is not necessarily extended at those scales. In addition, the concept of particle number cannot be defined at Planck scales.

Challenge 289

So, why is there something instead of nothing? Making love shows that there is no difference between the two options!

▪ Sex makes us *dream*. When we dream, especially at night, we often look at the sky. How far is it away? How many atoms are enclosed by it? How old is it? These questions have an answer for small distances and for large distances; but for the whole of the sky or the whole of nature they cannot have one, as there is no way to be outside of the sky in order to measure it. In fact, each of the impossibilities to measure nature at smallest distances are found again at the largest scales. There seems to be a fundamental equivalence, or, as physicists say, a *duality* between the largest and the smallest distances.

Ref. 8

The coming years will hopefully show how we can translate these results into an even more precise description of motion and of nature. In particular, this description should allow us to reduce the number of unexplained properties of nature.

In summary, making love is a good physics lesson. Enjoy the rest of your day.

References

- 1 An attempt to explain the lack of women in physics is made in MARGARET WERTHEIM, *Pythagoras' Trousers – God, Physics, and the Gender Wars*, Fourth Estate, 1997. Cited on page 721.
- 2 The consequences of memory loss in this case are already told by VOLTAIRE, *Aventure de la mémoire*, 1775. Cited on page 722.
- 3 A picture of objects in a red hot oven and at room temperature is shown in C.H. BENNETT, *Demons, Engines, and the Second Law*, Scientific American **255**, pp. 108–117, November 1987. Cited on page 724.
- 4 The famous quote is found at the beginning of chapter XI, 'The Physical Universe', in ARTHUR EDDINGTON, *The Philosophy of Physical Science*, Cambridge, 1939. Cited on page 725.
- 5 See the first intermezzo for details and references. Cited on page 726.
- 6 Details can be found in Chapter XII of this text, a reworked version of the pages published in French as CHRISTOPH SCHILLER, *Le vide diffère-t-il de la matière?*, in E. GUNZIG & S. DINER, editeurs, *Le vide – Univers du tout et du rien – Des physiciens et des philosophes s'interrogent*, Les Éditions de l'Université de Bruxelles, 1998. Cited on page 728, 730.

- 7 An introduction to the sense of time due to electrical currents circulating in the brain is found in ... Cited on page 724.
- 8 For details of the arguments leading to duality, see section 32. It also includes suggestions supporting the notion that the universe is not a even a set, thus proposing a solution for Hilbert's sixth problem. Cited on page 730.



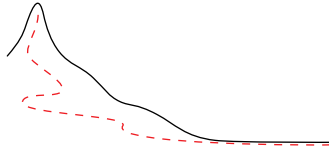

APPENDICES

Where the reference information necessary
for mountain ascents is given, allowing
to be prepared for
any other adventure as well.

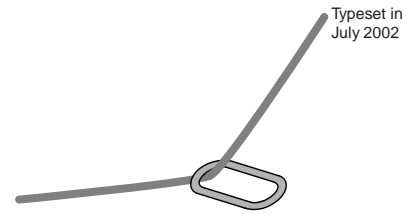

Newly introduced and defined concepts in this text are indicated by *italic typeface*. New definitions can also be found in the index, referred to by italic page numbers. Throughout the text SI units are used; they are defined in Appendix B. Experimental results are cited with limited precision, usually only two digits, as this is usually sufficient for discussion. Precise reference values can be found in Appendices B and C.

Ref. 1 In relativity we use the time convention, where the metric has the signature $(+ - - -)$, as used by about 70% of the literature worldwide. We use indices i, j, k for three-vectors, and indices a, b, c , etc. for four-three-vectors. Other conventions specific to general relativity are explained in the corresponding chapter.

The symbols used in the text

To avoide the tedious repetition of these woordes: is equalle to: I will sette as I doe often in woorke use, a paire of paralleles, or Gemowe lines of one lengthe, thus: = , bicause noe .2. thynges, can be moare equalle.
Robert Recorde*

Books are collections of symbols. Most symbols have been developed over hundreds of years; only the clearest and simplest are now in use. In this mountain ascent, the symbols used as abbreviations for *physical* quantities are all taken from the Latin or Greek alphabets. They are always defined in the context where they are used. The symbols designating units, constants, and particles are defined in Appendices B and C. All conform as much as possible to the ISO standard.

Ref. 2 *Mathematical* symbols used in this text, in particular those for operations and relations, are given in the following list, together with their origin.

- + , - plus, minus; the plus sign is derived from Latin ‘et’ — German mathematicians, end of 15th century
- $\sqrt{\quad}$ read as ‘square root’; the sign stems from a deformation of the letter ‘r’, initial of the Latin ‘radix’ — used by K. Rudolff in 1525
- = equal to — Italian mathematicians, early 16th century, then brought to England by R. Recorde

Ref. 2 * Robert Recorde (ca.1510–1558), English mathematician and physician; he died in prison, though not for his false pretention to be the inventor of the equal sign, which he simply took from his Italian colleagues, but for a smaller crime, namely debth. The quotation is from his *The Whetstone of Witte*, 1557.

{ }, [], ()	grouping symbols — use starts in the 16th century
>, <	larger than, smaller than — T. Harriot 1631
×	multiplied with, times — W. Oughtred 1631
:	divided by — G. Leibniz 1684
·	multiplied with, times — G. Leibniz 1698
a^n	power — R. Descartes 1637
x, y, z	coordinates, unknowns — R. Descartes 1637
$ax + by + c = 0$	constants and equations for unknowns — R. Descartes 1637
$d/dx, d^2x, \int y dx$	derivative, differential, integral — G. Leibniz 1675
φx	function of x — J. Bernoulli 1718
$f(x), f(x)$	function of x — L. Euler 1734
$\Delta x, \Sigma$	difference, sum — L. Euler 1755
\neq	is different from — L. Euler 18th century
$\partial/\partial x$	partial derivative, read like ‘ d/dx ’ — it was deduced from cursive form of the letter ‘dey’ of the cyrillic alphabet by A. Legendre in 1786
Δ	Laplace operator — R. Murphy 1833
$ x $	absolute value — K. Weierstrass 1841
∇	read as ‘nabla’ — introduced by W. Hamilton in 1853, from the shape of an old egyptian musical instrument
$[x]$	the measurement unit of a quantity x — 20th century
∞	infinity — J. Wallis 1655
π	$4 \arctan 1$ — H. Jones 1706
e	$\lim_{n \rightarrow \infty} (1 + 1/n)^n$ — L. Euler 1736
i	$+\sqrt{-1}$ — L. Euler 1777
\cup, \cap	set union and intersection — G. Peano 1888
\in	element of — G. Peano 1888
\emptyset	empty set — André Weil as member of the N. Bourbaki group in the early 20th century

Other signs used here have more complicated origins. The & sign is a contraction of Latin ‘et’ meaning ‘and’, as often is more clearly visible in its variations, such as \mathcal{E} , the common italic form. Ref. 4

The section sign § dates from the 13th century in northern Italy, as was shown by the German palaeographer Paul Lehmann. It was derived from ornamental versions of the capital letter C for ‘capitulum’, i.e. ‘little head’ or ‘chapter.’ The sign appeared first in legal texts, where it is still used today, and then spread also into other domains. Ref. 5

The paragraph ¶ sign was derived from a simpler ancient form looking like the Greek letter Γ , a sign which was used in manuscripts from ancient Greece until way into the middle ages to mark the start of a new text paragraph. In the middle ages it took the modern form because probably a letter c for ‘caput’ was added in front of it.

The punctuation signs used in sentences with modern Latin alphabets, such as , . ; : ! ? ‘ ’ » « – () ... , each have their own history. Many are from ancient Greece, but the question mark is from the court of Charlemagne, and exclamation marks appear first in the 16th Ref. 6

Ref. 7 century.* The @ or *at-sign* may stem from a medieval abbreviation of Latin *ad*, meaning ‘at’, in a similar way as the & sign evolved. In recent years, the *smiley* :-) and its variations has become popular. The smiley is in fact a new edition of the ‘point of irony’ which had been proposed already, without success, by A. de Brahm (1868–1942).

Ref. 8 The most important sign of all, the white space separating words, was due to Celtic and Germanic influences when these people started using the Latin alphabet. It became commonplace only between the 9th and the 13th century, depending on the language in question.

The Latin alphabet

Challenge 476 This text is written using the Latin alphabet. By the way, this implies that its pronunciation *cannot* be explained in print, in contrast to that of any other alphabet. The Latin alphabet was derived from the etruscan, which itself was a derivation of the Greek alphabet. The main forms are

from the 6th century BCE onwards, the *ancient* Latin alphabet:

A B C D E F Z H I K L M N O P Q R S T V X

from the 2nd century BCE until the 11th century, the *classical* Latin alphabet:

A B C D E F G H I K L M N O P Q R S T V X Y Z

The Latin alphabet was spread around Europe, Africa and Asia by the Romans during their conquests; due to its simplicity it was adopted by numerous modern languages. The letter G was added in the third century BCE by the first Roman to run a fee paying school, Spurius Carvilius Ruga, by adding a horizontal bar to the letter C, and substituting the letter Z, which was not used in Latin any more.

In the second century BCE, after the conquest of Greece, the Romans included the letters Y and Z from the Greek alphabet at the end of their own (therefore effectively reintroducing the Z) in order to be able to write Greek words. This classical Latin alphabet was stable throughout the next one thousand years.

Ref. 10 Most modern ‘Latin’ alphabets usually include other letters. The letter W was introduced in the 11th century in French, and was then adopted in most other languages. The letters J and U were introduced in the 16th century in Italy, to distinguish them from I and V, which used to have both meanings. In other languages they are used for other sounds. Other Latin alphabets include more letters, such as the German *sharp s*, written ß, a contraction of ‘sz’, the nordic letters *thorn* and *eth*, taken from the futhark,** and others signs.

Similarly, lower case letters are not classical Latin; they date only from the middle ages. Like most accents such as ê or ä, who were also defined in the middle ages, they were introduced to save the then expensive paper surface by shortening printed words.

Outside a dog, a book is a man’s best friend.

* On the parenthesis see the beautiful book by J. LENNARD, *But I digress*, Oxford University Press, 1991.

** The Runic script or *Futhark*, a type of alphabet used in the middle ages in Germanic countries, in the anglo-saxon sphere, and in the nordic countries, probably also derives from the etruscan alphabet. As the name says, the first letters were f, u, th, a, r, k (in other regions f, u, th, o, r, c). The third letter is the letter thorn mentioned above; it is often written ‘Y’ in old English, as in ‘Ye Olde Shoppe.’

Inside a dog, it's too dark to read.
Groucho Marx

The Greek alphabet

The Greek alphabet in turn was derived from the Phoenician or a similar northern Semitic alphabet in the 10th century BCE. In contrast to the Etruscan and Latin alphabets, each letter has a proper name, as was the case for the Phoenician alphabet and many of its derivatives. The Greek letter names of course are the origin of the term *alphabet* itself. Ref. 9

In the tenth century BCE, the *ancient* Greek alphabet consisted of the upper case letters only. In the 6th century BCE several letters were dropped, a few new ones and the lower case versions were added, giving the *classic* Greek alphabet. Still later, accents, subscripts and the breathings were introduced. The following table also gives the values the letters took when they were used as numbers. For this special use the obsolete ancient letters were kept also during the classical period; thus they also have a lower case form.

ancient	classic	name	correspondence		ancient	classic	name	correspondence	
A	Α α	Alpha	a	1	N	Ν ν	Nu	n	50
B	Β β	Beta	b	2	Ξ	Ξ ξ	Xi	x	60
Γ	Γ γ	Gamma	g, n ^a	3	O	Ο ο	Omicron	o	70
Δ	Δ δ	Delta	d	4	Π	Π π	Pi	p	80
E	Ε ε	Epsilon	e	5	Λ λ		Sampi ^c	s	900
F Ϝ		Digamma ^b	w	6			Qoppa	q	90
Z	Ζ ζ	Zeta	z	7	P	Ρ ρ	Rho	r, rh	100
H	Η η	Eta	e	8	Σ	Σ σ, ς	Sigma	s	200
Θ	Θ θ	Theta	th	9	T	Τ τ	Tau	t	300
I	Ι ι	Iota	i, j	10		Υ υ	Upsilon	y, u ^d	400
K	Κ κ	Kappa	k	20		Φ φ	Phi	ph, f	500
Λ	Λ λ	Lambda	l	30		Χ χ	Chi	ch	600
M	Μ μ	Mu	m	40		Ψ ψ	Psi	ps	700
						Ω ω	Omega	o	800

a. Only if before velars, i.e. before kappa, gamma, xi and chi.

b. 'Digamma' or 'stigma', as it is also called, are names deduced from the way the letter looks. The original letter name, also giving its pronunciation, was 'waw'.

c. The letter sampi was positioned after omega in later times.

d. Only if second letter in diphthongs.

The Latin correspondence in the list is the standard classical one, used in writing of Greek words. The question of the *pronunciation* of Greek has been a hot issue in specialist circles; the traditional *Erasmian* pronunciation does not correspond to the results of linguistic research, nor to the modern Greek one. (In modern Greek, pronunciation is different for β, which is now pronounced 'v', and for η, which is now pronounced 'i:'.) Obviously, the pronunciation of Greek varied from region to region and with time. For attic, the main dialect spoken in the classical period, the question is now settled. Linguistic research showed

This is a section of the freely downloadable e-textbook

Motion Mountain

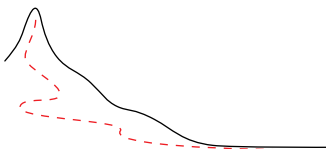

Hiking beyond space and time along the concepts of modern physics

available at
www.motionmountain.org

Copyright © 1997, 1998, 1999, 2000, 2001, 2002 by Christoph Schiller

To the kind reader

In exchange for getting this section for free, I ask you for a short email on some of the following:

- Which page was boring?
- Did you find any mistakes?
- What else were you expecting?
- What was hard to understand?

Of course, any other suggestion is welcome. This section is part of a physics text written over many years. The text lives and grows through the feedback from its readers, who help to improve and to complete it. For a particularly useful contribution (send it in english, italian, dutch, german, spanish, portuguese, or french) you will be mentioned in the foreword of the text, or receive a small reward, or both.

Enjoy!

Christoph Schiller
cs@motionmountain.org

Challenge 493

that chi, phi, and theta were less aspirated than usually pronounced, and sounded like the initials of ‘cat’, ‘perfect’ and ‘tin’; moreover, the zeta seems to have been pronounced more like ‘zd’ as in ‘buzzed’. For the vowels, contrary to tradition, epsilon is closed and short whereas eta is open and long, omicron is closed and short, whereas omega is wide and long, and upsilon is really a ‘u’ sound like in ‘boot’, not a French ‘u’ or German ‘ü.’

The Greek vowels can have rough or smooth *breathings*, as well as acute, grave, circumflex or dieresis *accents*, and *subscripts*. Breathings, used also on ρ, determine whether the letter is aspirated. Accents, interpreted only as stresses in the Erasmian pronunciation, actually represented pitches. Classical Greek could have up to three added signs per letter; modern Greek never has more than one accent.

A descendant of the Greek alphabet* is the *cyrillic alphabet*, used with slight variations in many slavic languages, such as Russian. However, there exists no standard transcription from cyrillic to Latin, so that often the same author is spelled differently in different countries and even in different occasions.

The Hebrew alphabet and other scripts

The phoenician alphabet is also at the origin of the Hebrew alphabet, which begins

Ref. 3

letter	name	corr.
א	aleph	a
ב	beth	b
ג	gimel	g
ד	daleth	d
etc.		

Only the first of these letters is commonly used in mathematics.

See page 432

There are a few additional alphabets in the world, some having a sign for each *sound*, such as Arabic and the Hieroglyphic script, and some having a sign for each *syllable*, such as Maya, Korean, or Japanese. In addition there are non-alphabetic writing systems, having signs for each *word*, such as Chinese. Even though there are about 7000 languages on earth, there are only about *two dozen* writing systems. For physical and mathematical formulas though, the sign system presented here, based on Latin and Greek letters, is a standard the world over. It is used independently of the writing system of the text containing it.

* The Greek alphabet also was at the origin of the *Gothic alphabet*, which was defined in the 4th century by Wulfila for the Gothic language, using also a few signs from the Latin and futhark scripts.

The Gothic alphabet is not to be confused with the so-called *Gothic letters*, a style of the *Latin* alphabet used all over Europe from the 11th century onwards. In Latin countries, Gothic letters were replaced in the 16th century by the *antiqua*, the ancestor of the type in which this text is set. In other countries, Gothic letters remained in use much later. They were used in type and handwriting in Germany until in 1941 the national-socialist government suddenly abolished them. They remain in sporadic use across Europe. In many physics and mathematics books, gothic letters are used to denote vector quantities instead of bold letters.

Digits and numbers

Both the digits and the method used in this text to write numbers stem from India. They were brought to the mediterranean by arabic mathematicians in the middle ages. The number system used in this text is thus much younger than the alphabet. The signs 0, 2, 3 and 7 still resemble closely those used in arabic writing, if they are turned clockwise by 90°. * The ‘arabic’ numbers were made popular in Europe by Leonardo of Pisa, called Fibonacci, in his book *Liber Abaci*, which he published in 1202. From that day on mathematics was not the same any more. Everybody with paper and pen was now able to calculate and write down numbers as large as reason allows, and even larger, and to perform calculations with them. The indian-arabic method brought two innovations: the *positional system* of writing numbers, and the digit zero. The positional system described by Fibonacci was so much more efficient to write numbers that it completely replaced the previous *Roman number system*, which writes 1998 as IIMM or MCMIIIC or MCMDCVIII, as well as the *Greek number system*, in which the Greek letters were used for numbers, as shown above. In short, compared to the previous systems the indian-arabic numbers are a much better technology. Indeed, the indian-arabic system is so practical that calculations done on paper completely eliminated calculations with help of the *abacus*, which therefore fell in disuse. The abacus is still in use only in those countries which do not use a positional system to write numbers. Similarly, only the positional number system allows mental calculations and made calculating prodigies possible. **

Calendars

The many ways to keep track of time differ greatly across the civilisations. The most common calendar, the one used in this text, is at the same time one of the most absurd, as it is a compromise between various political forces who tried to shape it.

In ancient times, independent localized entities, such as tribes or cities, preferred *lunar* calendars, because lunar time keeping is easily organized locally. This led to the use of the month as calendar unit. Centralized states imposed *solar* calendars, based on the year. Solar systems require astronomers and thus a central authority to finance them. For various reasons, farmers, politicians, tax collectors, astronomers, and some, but not all, religious groups wanted the calendar to follow the solar year as precisely as possible. The compromises necessary between months and years are the origin of leap days. The compromises require that different months in a year have different length; in addition, their length is different in different calendars. The most commonly used year-month structure was organized over 2000 years ago by Julius Ceasar, and is thus called the *julian calendar*.

The week is an invention of Babylonia, and was taken over and spread by various religious groups. Even though about three thousand years old, it was included in the calendar only around the year 400, towards the end of the Roman empire. The final change took place

* The story of the development of the numbers is told most interestingly by G. IFRAH, *Histoire universelle des chiffres*, Seghers, 1981, which has been translated into several languages. He sums up the genealogy in ten beautiful tables, one for each digit, at the end of the book.

** About the stories and the methods of calculating prodigies, see the fascinating book by STEVEN B. SMITH, *The great mental calculators – The psychology, methods, and lives of the calculating prodigies*, Columbia University Press, 1983. One can easily learn to emulate them.

between 1582 and 1917 (depending on the country), when more precise measurements of the solar year were used to set a new method to determine leap days, a method still in use today. Together with a reset of the date and the fixation of the week rhythm, this standard is called the *gregorian calendar* or simply the *modern calendar*. It is used by a majority of the world's population.

Despite this complexity, the modern calendar allows you to determine the day of the week of a given date in your head. Just do the following:

- take the last two digits of the year, divide by 4, discarding any fraction,
- add the last two digits of the year,
- subtract 1 for January or February of a leap year,
- add 6 for 2000's or 1600's, 4 for 1700's or 2100's,
2 for 1800's and 2200's, and 0 for 1900's or 1500's,
- add the day of the month,
- add the month key value, namely 144 025 036 146 for JFM AMJ JAS OND.

The remainder after division by 7 gives the day of the week, with the correspondence 1 / 2 / 3 / 4 / 5 / 6 / 7 or 0 meaning sunday / monday / tuesday / wednesday / thursday / friday / saturday.*

Counting years is of course a matter of preference. The oldest method not attached to political power structures was the method used in ancient Greece, when years were counted in function of the Olympic games. In those times, people used to say e.g. that they were born in the first year of the 23rd olympiad. Later, political powers always imposed counting years from some important event onwards.** Maybe reintroducing the Olympic counting is worth considering?

Abbreviations and eponyms or concepts?

The scourge of modern physics are sentences like the following:

The EPR paradox in the Bohm formulation can perhaps be resolved using the GRW approach, using the WKB approximation of the Schrödinger equation.

* Remembering the intermediate result for the current year can simplify things even more, especially since the dates 4.4., 6.6., 8.8., 10.10., 12.12., 9.5., 5.9., 7.11., 11.7., and the last day of february all fall on the same day of the week, namely on the year's intermediate result plus 4.

** The present counting of year was defined in the middle ages by setting the date for the foundation of Rome to the year 753 BCE, or *753 Before Common Era*, and then counting backwards, implying that the BCE years behave like negative numbers. However, the year 1 follows directly after the year 1 BCE; there was no year 0.

Some other standards set by the Roman empire explain several abbreviations used in the text:

- ca. is a Latin abbreviation for 'circa' and means 'roughly'.
- i.e. is a Latin abbreviation for 'ita est' and means 'that is'.
- e.g. is a Latin abbreviation for 'exempli gratia' and means 'for the sake of example'.

By the way, 'idem' means 'the same'. Also terms like frequency, acceleration, velocity, mass, force, momentum, inertia, gravitation and temperature are Latin. In fact, there is a strong case to be made that the language of science has been Latin for over two thousand years. In Roman times it was Latin with Latin grammar, in modern times it switched to Latin vocabulary and French grammar, then for a short time to Latin with German grammar, after which it changed to Latin vocabulary and British/American grammar.

Many units of measurement also date from Roman times, as explained in the next appendix. Even the infatuation with Greek technical terms, as shown in coinages such as 'gyroscope', 'entropy', or 'proton', dates from Roman times.

Using such vocabulary is the best method to make language unintelligible to outsiders. First of all, it uses abbreviations, which is a shame. On top of this, the sentence uses people's names to characterize concepts, i.e. it uses *eponyms*. Originally, eponyms were intended as tributes to outstanding achievements. Today, when formulating new laws or variables has become nearly impossible, the spread of eponyms intelligible only to a steadily decreasing number of people simply reflects an increasingly ineffective drive to fame.

Eponyms are a lasting proof of the lack of imagination of scientists. Eponyms are avoided as much as possible in our walk; mathematical equations or entities are given *common* names wherever possible. People's names are then used as appositions to these names. For example, 'Newton's equation of motion' is never called 'Newton's equation', 'Einstein's field equations' is used instead of 'Einstein's equations', 'Heisenberg's equation of motion' in place of 'Heisenberg's equation'.

However, some exceptions are inevitable for certain terms within modern physics for which no real alternatives exist. The Boltzmann constant, the Planck units, the Compton wavelength, the Casimir force, Lie groups and the Virasoro algebra are examples. In compensation, it is made sure that the definitions can be looked up using the index.



References

- 1 For a clear overview of the various sign conventions in general relativity, see the front cover of CHARLES W. MISNER, KIP S. THORNE & JOHN A. WHEELER, *Gravitation*, Freeman, 1973. We use the gravitational sign conventions of HANS C. OHANIAN & REMO RUFFINI, *Gravitazione e spazio-tempo*, Zanichelli, 1997. Cited on page 801.
- 2 See for example the voice 'Mathematical notation' in the *Encyclopedia of Mathematics*, 10 volumes, Kluwer Academic Publishers, Dordrecht, 1988-1993. There is also the beautiful <http://members.aol.com/jeff570/mathsym.html> web site, and the extensive research by FLORIAN CAJORI, *A History of Mathematical Notations*, 2 volumes, The Open Court Publishing Co., 1928-1929. Cited on page 801, 801.
- 3 DAVID R. LIDE, editor, *CRC Handbook of Chemistry and Physics*, 78th edition, CRC Press, 1997. This classic reference work appears in a new edition every year. The full Hebrew alphabet is given on page 2-90. The list of abbreviations of physical quantities for use in formulas approved by ISO, IUPAP and IUPAC can also be found there. Cited on page 801, 806.
- 4 JAN TSCHICHOLD, *Vormveranderingen van het &-teken*, Uitgeverij De Buitenkant, 1994. Cited on page 802.
- 5 PAUL LEHMANN, *Erforschung des Mittelalters – Ausgewählte Abhandlungen und Aufsätze*, Anton Hiersemann, Stuttgart, 1961, pp. 4-21. Cited on page 802.
- 6 M.B. PARKES, *Pause and Effect: An Introduction to the History of Punctuation in the West*, University of California Press, 1993. Cited on page 802.
- 7 This is explained by BERTHOLD LOUIS ULLMAN, *Ancient Writing and its Influence*, 1932. Cited on page 803.
- 8 BERNARD BISCHOFF, *Paläographie des römischen Altertums und des abendländischen Mittelalters*, Erich Schmidt Verlag, 1979, pp. 215-219. Cited on page 803.
- 9 HANS JENSEN, *Die Schrift*, Berlin, 1969, translated into English as *Sign, Symbol and Script: an Account of Man's Efforts to Write*, Putnam's Sons, New York. Cited on page 804.

- 10** About the thorn and the eth, see the extensive report to be found on the web site <http://www.indigo.ie/egt/standards/iso10646/wynnyogh/thorn.html>. Cited on page 803.
- 11** The connections between Greek roots and many French words, and thus many English ones, can be used to rapidly build up a vocabulary of ancient Greek without much study, as shown by the practical collection by J. CHAINEUX, *Quelques racines grecques*, Wetteren – De Meester, 1929. Cited on page 808.



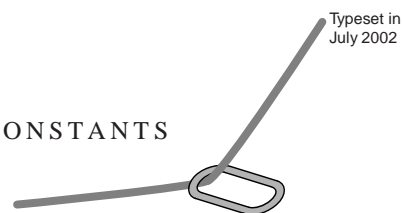

Measurements are comparisons. The standard used for the comparison is called a *unit*. Many different systems of units have been used throughout the world. Unit systems are standards, and always confer a lot of power to the organization in charge of them, as can be seen most clearly in the computer industry; in the past the same happened for measurement units. To avoid misuse by authoritarian institutions, to eliminate at the same time all problems with differing, changing and irreproducible standards, and – this is not a joke – to simplify tax collection, already in the 18th century scientists, politicians, and economists have agreed on a set of units. It is called the *Système International d’Unités*, abbreviated *SI*, and is defined by an international treaty, the ‘Convention du Mètre’. The units are maintained by an international organization, the ‘Conférence Générale des Poids et Mesures’, and its daughter organizations, the ‘Commission Internationale des Poids et Mesures’ and the ‘Bureau International des Poids et Mesures’, which all originated in the times just before the French revolution.

Ref. 1

All SI units are built from seven *base units* whose official definitions, translated from French into English, are the following, together with the date of their formulation:

- ‘The *second* is the duration of 9 192 631 770 periods of the radiation corresponding to the transition between the two hyperfine levels of the ground state of the caesium 133 atom.’ (1967)*
- ‘The *metre* is the length of the path travelled by light in vacuum during a time interval of 1/299 792 458 of a second.’ (1983)
- ‘The *kilogram* is the unit of mass; it is equal to the mass of the international prototype of the kilogram.’ (1901)*
- ‘The *ampere* is that constant current which, if maintained in two straight parallel conductors of infinite length, of negligible circular cross-section, and placed 1 metre apart in vacuum, would produce between these conductors a force equal to $2 \cdot 10^{-7}$ newton per metre of length.’ (1948)
- ‘The *kelvin*, unit of thermodynamic temperature, is the fraction 1/273.16 of the thermodynamic temperature of the triple point of water.’ (1967)*
- ‘The *mole* is the amount of substance of a system which contains as many elementary entities as there are atoms in 0.012 kilogram of carbon 12.’ (1971)*
- ‘The *candela* is the luminous intensity, in a given direction, of a source that emits monochromatic radiation of frequency $540 \cdot 10^{12}$ hertz and has a radiant intensity in that

direction of (1/683) watt per steradian.’ (1979)*

Note that both time and length units are defined as certain properties of a standard example of motion, namely light. This is an additional example making the point that the observation of motion as the fundamental type of change is a *prerequisite* for the definition and construction of time and space. By the way, the proposal of using light was made already in 1827 by Jacques Babinet.*

From these basic units, all other units are defined by multiplication and division. In this way, all SI units have the following properties:

- They form a system with *state-of-the-art precision*; all units are defined in such a way that the precision of their definition is higher than the precision of commonly used measurements. Moreover, the precision of the definitions are regularly improved. The present relative uncertainty of the definition of the the second is around 10^{-14} , for the metre about 10^{-10} , for the ampere 10^{-7} , for the kilogram about 10^{-9} , for the kelvin 10^{-6} , for the mole less than 10^{-6} , and for the candela 10^{-3} .

- They form an *absolute* system; all units are defined in such a way that they can be reproduced in every suitably equipped laboratory, independently, and with high precision. This avoids as much as possible any misuse by the standard setting organization. (At present, the kilogram, still defined with help of an artefact, is the last exception to this requirement; extensive research is under way to eliminate this artefact from the definition – an international race that will take a few more years.)

- They form a *practical* system: base units are adapted to daily life quantities. Frequently used units have standard names and abbreviations. The complete list includes the seven base units as well as the derived, the supplementary and the admitted units:

The *derived* units with special names, in their official English spelling, i.e. without capital letters and accents, are:

name	abbreviation & definition	name	abbreviation & definition
hertz	Hz = 1/s	newton	N = kg m/s ²
pascal	Pa = N/m ² = kg/m s ²	joule	J = Nm = kg m ² /s ²
watt	W = kg m ² /s ³	coulomb	C = As
volt	V = kg m ² /As ³	farad	F = As/V = A ² s ⁴ /kg m ²
ohm	Ω = V/A = kg m ² /A ² s ³	siemens	S = 1/Ω
weber	Wb = Vs = kg m ² /As ²	tesla	T = Wb/m ² = kg/As ²
henry	H = Vs/A = kg m ² /A ² s ²	degree Celsius *	°C
lumen	lm = cd sr	lux	lx = lm/m ² = cd sr/m ²
becquerel	Bq = 1/s	gray	Gy = J/kg = m ² /s ²
sievert	Sv = J/kg = m ² /s ²	katal	kat = mol/s

* The international prototype of the kilogram is a platinum-iridium cylinder kept at the BIPM in Sèvres, in France. For more details on the levels of the caesium atom, consult a book on atomic physics. The Celsius scale of temperature θ is defined as: $\theta/^\circ\text{C} = T/\text{K} - 273.15$; note the small difference with the number appearing in the definition of the kelvin. When the mole is used, the elementary entities must be specified and may be atoms, molecules, ions, electrons, other particles or specified groups of such particle. In its definition, it is understood that the carbon 12 atoms are unbound, at rest and in their ground state. The frequency of the light in the definition of the candela corresponds to 555.5 nm, i.e. green colour, and is the wavelength for which the eye is most sensitive.

* Jacques Babinet (1794–1874), French physicist who published important work in optics.

We note that in all definitions of units, the kilogram only appears to the powers of 1, 0 and -1. The final explanation for this fact appeared only recently.

The *radian* (rad) and the *steradian* (sr) are *supplementary SI units* for angle, defined as the ratio of arc length and radius, and for solid angle, defined as the ratio of the subtended area and the square of the radius, respectively.

The *admitted non-SI units* are *minute, hour, day* (for time), *degree* $1^\circ = \pi/180 \text{ rad}$, *minute* $1' = \pi/10\,800 \text{ rad}$, *second* $1'' = \pi/648\,000 \text{ rad}$ (for angles), *litre*, and *tonne*.

All other units are to be avoided.

All SI units are made more practical by the introduction of standard names and abbreviations for the powers of ten, the so-called *prefixes*: *

name	abbr.	name	abbr.	name	abbr.	name	abbr.
10^1	deca da	10^{-1}	deci d	10^{18}	Exa E	10^{-18}	atto a
10^2	hecto h	10^{-2}	centi c	10^{21}	Zetta Z	10^{-21}	zepto z
10^3	kilo k	10^{-3}	milli m	10^{24}	Yotta Y	10^{-24}	yocto y
10^6	Mega M	10^{-6}	micro μ	unofficial:		Ref. 3	
10^9	Giga G	10^{-9}	nano n	10^{27}	Xenta X	10^{-27}	xenno x
10^{12}	Tera T	10^{-12}	pico p	10^{30}	Wekta W	10^{-30}	weko w
10^{15}	Peta P	10^{-15}	femto f	10^{33}	Vendekta V	10^{-33}	vendeko v
				10^{36}	Udekta U	10^{-36}	udeko u

- SI units form a *complete* system; they cover in a systematic way the complete set of observables of physics. Moreover, they fix the units of measurements for physics and for all other sciences as well.

- They form a *universal* system; they can be used in trade, in industry, in commerce, at home, in education, and in research. They could even be used by other civilisations, if they existed.

- They form a *coherent* system; the product or quotient of two SI units is also a SI unit. This means that in principle, the same abbreviation ‘SI’ could be used for every SI unit.

The SI units are not the only possible set that fulfils all these requirements, but they form the only existing system doing so. **

* Some of these names are invented (yocto to sound similar to Latin octo ‘eight’, zepto to sound similar to Latin septem, yotta and zetta to resemble them, exa and peta to sound like the Greek words of six and five, the unofficial ones to sound similar to the Greek words for nine, ten, eleven, and twelve), some are from Danish/Norwegian (atto from atten ‘eighteen’, femto from femten ‘fifteen’), some are from Latin (from mille ‘thousand’, from centum ‘hundred’, from decem ‘ten’, from nanus ‘dwarf’), some are from Italian (from piccolo ‘small’), some are Greek (micro is from μικρός ‘small’, deca/deka from δέκα ‘ten’, hecto from ἑκατόν ‘hundred’, kilo from χίλιοι ‘thousand’, mega from μέγας ‘large’, giga from γίγας ‘giant’, tera from τέρας ‘monster’).

Challenge 510 Translate: I was caught in such a traffic jam that I needed a microcentury for a picoparsec and that my car’s fuel consumption was two tenths of a square millimetre.

** Most non-SI units still in use in the world are of Roman origin: the mile comes from ‘milia passum’ (used to be one thousand strides of about 1480 mm each; today a nautical mile is a minute of arc), inch comes from ‘uncia/onzia’ (a twelfth – now of a foot); pound (from pondere ‘to weigh’) is used as a translation of ‘libra’ – balance – which is the origin of its abbreviation *lb*; even the habit of counting in dozens instead of tens is Roman in origin. These and all other similarly funny units – like the system in which all units start with ‘f’, and which uses furlongs/fortnights as unit for velocity – are now officially defined as multiples of SI units.

This is a section of the freely downloadable e-textbook

Motion Mountain

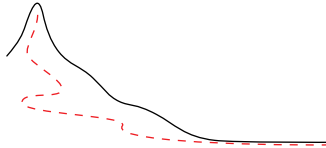

Hiking beyond space and time along the concepts of modern physics

available at
www.motionmountain.org

Copyright © 1997, 1998, 1999, 2000, 2001, 2002 by Christoph Schiller

To the kind reader

In exchange for getting this section for free, I ask you for a short email on some of the following:

- Which page was boring?
- Did you find any mistakes?
- What else were you expecting?
- What was hard to understand?

Of course, any other suggestion is welcome. This section is part of a physics text written over many years. The text lives and grows through the feedback from its readers, who help to improve and to complete it. For a particularly useful contribution (send it in english, italian, dutch, german, spanish, portuguese, or french) you will be mentioned in the foreword of the text, or receive a small reward, or both.

Enjoy!

Christoph Schiller
cs@motionmountain.org

Challenge 527

Planck's natural units

Since the exact form of many equations depends on the used system of units, theoretical physicists often use unit systems optimized for producing simple equations. In microscopic physics, the system of *Planck's natural units* is frequently used. They are automatically introduced by setting $c = 1$, $\hbar = 1$, $G = 1$, $k = 1$, $\epsilon_0 = 1/4\pi$ and $\mu_0 = 4\pi$ in equations written in SI units. Planck units are thus defined from combinations of fundamental constants; those corresponding to the fundamental SI units are given in the table. * The table is also useful for converting equations written in natural units back to SI units; every quantity X is substituted by X/X_{Pl} .

Table 59 Planck's natural units

Name	definition	value
Basic units		
the Planck length	$l_{\text{Pl}} = \sqrt{\hbar G/c^3}$	$= 1.6160(12) \cdot 10^{-35} \text{ m}$
the Planck time	$t_{\text{Pl}} = \sqrt{\hbar G/c^5}$	$= 5.3906(40) \cdot 10^{-44} \text{ s}$
the Planck mass	$m_{\text{Pl}} = \sqrt{\hbar c/G}$	$= 21.767(16) \mu\text{g}$
the Planck current	$I_{\text{Pl}} = \sqrt{4\pi\epsilon_0 c^6/G}$	$= 3.4793(22) \cdot 10^{25} \text{ A}$
the Planck temperature	$T_{\text{Pl}} = \sqrt{\hbar c^5/Gk^2}$	$= 1.4171(91) \cdot 10^{32} \text{ K}$
Trivial units		
the Planck velocity	$v_{\text{Pl}} = c$	$= 0.3 \text{ Gm/s}$
the Planck angular momentum	$L_{\text{Pl}} = \hbar$	$= 1.1 \cdot 10^{-34} \text{ Js}$
the Planck action	$S_{\text{aPl}} = \hbar$	$= 1.1 \cdot 10^{-34} \text{ Js}$
the Planck entropy	$S_{\text{ePl}} = k$	$= 13.8 \text{ yJ/K}$
Composed units		
the Planck mass density	$\rho_{\text{Pl}} = c^5/G^2\hbar$	$= 5.2 \cdot 10^{96} \text{ kg/m}^3$
the Planck energy	$E_{\text{Pl}} = \sqrt{\hbar c^5/G}$	$= 2.0 \text{ GJ} = 1.2 \cdot 10^{28} \text{ eV}$
the Planck momentum	$p_{\text{Pl}} = \sqrt{\hbar c^3/G}$	$= 6.5 \text{ Nm}$
the Planck force	$F_{\text{Pl}} = c^4/G$	$= 1.2 \cdot 10^{44} \text{ N}$
the Planck power	$P_{\text{Pl}} = c^5/G$	$= 3.6 \cdot 10^{52} \text{ W}$
the Planck acceleration	$a_{\text{Pl}} = \sqrt{c^7/\hbar G}$	$= 5.6 \cdot 10^{51} \text{ m/s}^2$
the Planck frequency	$f_{\text{Pl}} = \sqrt{c^5/\hbar G}$	$= 1.9 \cdot 10^{43} \text{ Hz}$
the Planck electric charge	$q_{\text{Pl}} = \sqrt{4\pi\epsilon_0 c\hbar}$	$= 1.9 \text{ aC} = 11.7 e$
the Planck voltage	$U_{\text{Pl}} = \sqrt{c^4/4\pi\epsilon_0 G}$	$= 1.0 \cdot 10^{27} \text{ V}$
the Planck resistance	$R_{\text{Pl}} = 1/4\pi\epsilon_0 c$	$= 30.0 \Omega$

* The natural units x_{Pl} given here are those commonly used today, i.e. those defined using the constant \hbar , and not, as Planck originally did, by using the constant $h = 2\pi\hbar$. A similar, additional freedom of choice arises for the electromagnetic units, which can be defined with other factors than 4π in the expressions; for example, using $4\pi\alpha$, with the *fine structure constant* α , gives $q_{\text{Pl}} = e$. For the explanation of the numbers between brackets, the standard deviations, see page 819.

Name	definition	value
the Planck capacitance	$C_{\text{Pl}} = 4\pi\epsilon_0\sqrt{\hbar G/c^3}$	$= 1.8 \cdot 10^{-45} \text{ F}$
the Planck inductance	$L_{\text{Pl}} = (1/4\pi\epsilon_0)\sqrt{\hbar G/c^7}$	$= 1.6 \cdot 10^{-42} \text{ H}$
the Planck electric field	$E_{\text{Pl}} = \sqrt{c^7/4\pi\epsilon_0\hbar G^2}$	$= 6.5 \cdot 10^{61} \text{ V/m}$
the Planck magnetic flux density	$B_{\text{Pl}} = \sqrt{c^5/4\pi\epsilon_0\hbar G^2}$	$= 2.2 \cdot 10^{53} \text{ T}$

The natural units are important for another reason: whenever a quantity is sloppily called ‘infinitely small (or large)’, the correct expression is ‘small (or large) as the corresponding Planck unit’. As explained in the third part, this substitution is correct because almost all Planck units provide, within a factor of order one, the extreme value for the corresponding observable. Exceptions are those quantities for which many particle systems can exceed single particle limits, such as mass or electrical resistance.

See page 671

Other unit systems

In fundamental theoretical physics another system is also common. One aim of research being the calculation of the strength of all interactions, setting the gravitational constant G to unity, as is done when using Planck units, makes this aim more difficult to express in equations. Therefore one often only sets $c = \hbar = k = 1$ and $\mu_0 = 1/\epsilon_0 = 4\pi$,* leaving only the gravitational constant G in the equations. In this system, only one fundamental unit exists, but its choice is still free.

Often a standard length is chosen as fundamental unit, length being the archetype of a measured quantity. The most important physical observables are related by

$$\begin{aligned}
 [l] &= 1/[E] = [t] = [C] = [L] \quad , \\
 1/[l] &= [E] = [m] = [p] = [a] = [f] = [I] = [U] = [T] \quad , \\
 [l]^2 &= 1/[E]^2 = [G] = [P] = 1/[B] = 1/[E_{\text{el}}] \quad \text{and} \\
 1 &= [v] = [q] = [e] = [R] = [S_{\text{action}}] = [S_{\text{entropy}}] = \hbar = c = k = [\alpha]
 \end{aligned}$$

with the usual convention to write $[x]$ for the unit of quantity x . Using the same unit for speed and electric resistance is not to everybody’s taste, however, and therefore electricians do not use this system.**

In many situations, in order to get an impression of the energies needed to observe the effect under study, a standard energy is chosen as fundamental unit. In particle physics the common energy unit is the *electron Volt* (eV), defined as the kinetic energy acquired by

* Other definitions for the proportionality constants in electrodynamics lead to the gaussian unit system often used in theoretical calculations, the Heaviside-Lorentz unit system, the electrostatic unit system, and the electromagnetic unit system, among others. For more details, see the standard text by JOHN DAVID JACKSON, *Classical Electrodynamics*, 3rd edition, Wiley, 1998.

** The web page <http://www.chemie.fu-berlin.de/chemistry/general/units-en.html> allows to convert various units into each other.

In general relativity still another system is sometimes used, in which the *Schwarzschild radius* defined as $r_S = 2Gm/c^2$ is used to measure masses, by setting $c = G = 1$. In this case, in opposition to above, mass and length have the same dimension, and \hbar has dimension of an area.

an electron when accelerated by an electrical potential difference of 1 Volt ('proton Volt' would be a better name). Therefore one has $1 \text{ eV} = 1.6 \cdot 10^{-19} \text{ J}$, or roughly

$$1 \text{ eV} \approx \frac{1}{6} \text{ aJ}$$

Challenge 544

which is easily remembered. The simplification $c = \hbar = 1$ yields $G = 6.9 \cdot 10^{-57} \text{ eV}^{-2}$ and allows to use the unit eV also for mass, momentum, temperature, frequency, time and length, with the respective correspondences $1 \text{ eV} \hat{=} 1.8 \cdot 10^{-36} \text{ kg} \hat{=} 5.4 \cdot 10^{-28} \text{ Nm} \hat{=} 242 \text{ THz} \hat{=} 11.6 \text{ kK}$ and $1 \text{ eV}^{-1} \hat{=} 4.1 \text{ fs} \hat{=} 1.2 \mu\text{m}$.

To get some feeling for the unit eV, the following relations are useful. Room temperature, usually taken as 20°C or 293 K , corresponds to a kinetic energy per particle of 0.025 eV or 4.0 zJ . The highest particle energy measured so far is a cosmic ray of energy of $3 \cdot 10^{20} \text{ eV}$ or 48 J . Down here on the earth, an accelerator with an energy of about 230 GeV or 37 nJ for electrons has been built, and one with an energy of 10 TeV or $1.6 \mu\text{J}$ for protons will be built. Both are owned by CERN in Genève and have a circumference of 27 km .

Ref. 4

The lowest temperature measured up to now is 280 pK , in a system of Rhodium nuclei inside a special cooling system. The interior of that cryostat possibly is the coolest point in the whole universe. At the same time, the kinetic energy per particle corresponding to that temperature is also the smallest ever measured; it corresponds to 24 feV or $3.8 \text{ vJ} = 3.8 \cdot 10^{-33} \text{ J}$. For isolated particles, the record seems to be for neutrons: kinetic energies as low as 10^{-7} eV have been achieved, corresponding to De Broglie wavelengths of 60 nm .

Ref. 5

Curiosities

Here are a few facts making the concept of unit more vivid.

- Are you confused by the candela? The definition simply says that $683 \text{ cd} = 683 \text{ lm/sr}$ correspond to 1 W/sr . The candela is thus a unit for light power per angle, except that it is corrected for the eye's sensitivity: the candela measures only *visible* power per angle. Similarly, $683 \text{ lm} = 683 \text{ cd} \cdot \text{sr}$ correspond to 1 W , i.e. both the lumen and the watt measure power, or energy flux, except that the lumen measures only the *visible* part of the power. In English quantity names, the change is expressed by substituting 'radiant' by 'luminous'; e.g. the Watt measures *radiant* flux, whereas the lumen measure *luminous* flux.

The factor 683 is historical. A usual candle indeed emits a luminous intensity of about a candela. Therefore, at night, a candle can be seen up to a distance of one or two dozen kilometres. A 100 W incandescent light bulb produces 1700 lm , and the brightest light emitting diodes about 5 lm .

Challenge 561

The *irradiance* of sunlight is about 1300 W/m^2 on a sunny day; the *illuminance* is 120 klm/m^2 or 170 W/m^2 , reflecting the fact that most energy radiated from the sun to the earth is outside the visible spectrum.

- The highest achieved light intensities are in excess of 10^{18} W/m^2 , more than 15 orders of magnitude higher than the intensity of sunlight, and are achieved by tight focusing of pulsed lasers. The electric fields in such light pulses is of the same order of the field inside atoms; such a beam ionizes all matter it encounters.

Ref. 6

- The Planck length is roughly the de Broglie wavelength $\lambda_B = h/mv$ of a man walking comfortably ($m = 80 \text{ kg}$, $v = 0.5 \text{ m/s}$); this motion is therefore aptly called the 'Planck stroll.'

Ref. 7

▪ The Planck mass is equal to the mass of about 10^{19} protons. This is roughly the mass of a human embryo at about ten days of age.

▪ The second does not correspond to 1/86 400th of the day any more (it did so in the year 1900); the earth now takes about 86 400.002 s for a rotation, so that regularly the *International Earth Rotation Service* introduces a leap second to ensure that the sun is at the highest point in the sky at 12.00 o'clock sharp. * The time so defined is called *Universal Time Coordinate*. The velocity of rotation of the earth also changes irregularly from day to day due to the weather; the average rotation speed even changes from winter to summer due to the change in polar ice caps, and in addition that average decreases over time, due to the friction produced by the tides. The rate of insertion of leap seconds is therefore faster than every 500 days, and not completely constant in time.

▪ The most precisely measured quantities in nature are the frequency of certain millisecond pulsars, ** the frequency of certain narrow atomic transitions and the Rydberg constant of atomic hydrogen, which can all be measured as exactly as the second is defined. At present, this gives about 14 digits of precision.

▪ The most precise clock ever built, using microwaves, had a stability of 10^{-16} during a running time of 500 s. For longer time periods, the record in 1997 was about 10^{-15} ; but the area of 10^{-17} seems within technological reach. The precision of clocks is limited for short measuring times by noise, and for long measuring times by drifts, i.e. by systematic effects. The region of highest stability depends on the clock type and usually lies between 1 ms for optical clocks and 5000 s for masers. Pulsars are the only clock for which this region is not known yet; it lies at more than 20 years, which is the time elapsed since their discovery.

Ref. 8

Ref. 9

▪ The shortest times measured are the life times of certain ‘elementary’ particles; in particular, the D meson was measured to live less than 10^{-22} s. Such times are measured in a bubble chamber, where the track is photographed. Can you estimate how long the track is? (Watch out – if your result cannot be observed with an optical microscope, you made a mistake in your calculation).

Ref. 10

Challenge 578

▪ The longest measured times are the lifetimes of certain radioisotopes, over 10^{15} years, and the lower limit on of certain proton decays, over 10^{32} years. These times are thus much larger than the age of the universe, estimated to be twelve thousand million years.

Ref. 11

▪ The least precisely measured fundamental quantities are the gravitational constant G and the strong coupling constant α_s . Other, even less precisely known quantities, are the age of the universe and its density (see the astrophysical table below).

See page 822

▪ Variations of quantities are often much easier to measure than their values. For example, in gravitational wave detectors, the sensitivity achieved in 1992 was $\Delta l/l = 3 \cdot 10^{-19}$ for lengths of the order of 1 m. In other words, for a block of about a cubic metre of metal it is possible to measure length changes about 3000 times smaller than a proton radius. These set-ups are now being superseded by ring interferometers. Ring interferometers measuring frequency differences of 10^{-21} have already been built, and are still being improved.

Ref. 12

Ref. 13

* Their web site at <http://hpiers.obspm.fr> gives more information on the details of these insertions, as does <http://maia.usno.navy.mil>, one of the few useful military web sites. See also <http://www.bipm.fr>, the site of the BIPM.

** An overview of this fascinating work is given by J.H. TAYLOR, *Pulsar timing and relativistic gravity*, *Philosophical Transactions of the Royal Society, London A* **341**, pp. 117–134, 1992.

- Ref. 14 The Swedish astronomer Anders Celsius (1701–1744) originally set the freezing point at 100 degrees and the boiling point of water at 0 degrees. But the switch to today's scale was not successful. With the official definition of the Kelvin and the degree Celsius, at the standard pressure of 1013.25 Pa, water boils at 99.974 °C. Can you explain why it is not 100 °C any more?
- Challenge 595 The size of SI units is adapted to humans: heartbeat, human size, human weight, human temperature, human substance, etc. In a somewhat unexpected way they realize the saying by Protagoras, 25 centuries ago: 'Man is the measure of all things.'
- Challenge 612 The table of SI prefixes covers seventy-two decades. How many more will ever be needed? Even this extended list will include only a small part of the infinite number of possible decades. Why is this the case?
- Challenge 629 It is well-known that the French philosopher Voltaire, after meeting Newton, publicized the now famous story that the connection between the fall of objects and the motion of the moon was discovered by Newton when he saw an apple falling from a tree. More than a century later, just before the French revolution, a committee of scientists decided to take as unit of force precisely the force exerted by gravity on a *standard apple*, and name it after the English scientist. After extensive study, it was found that the mass of the standard apple was 101,9716 g; its weight was called 1 newton. Since then, in the museum in Sèvres near Paris, visitors can admire the standard metre, the standard kilogram, and the standard apple.*

Precision and accuracy of measurements

As explained on page 166, *precision* measures how well a result is reproduced when the measurement is repeated; *accuracy* is the degree to which a measurement corresponds to the actual value. Lack of precision is due to accidental or *random errors*; they are best measured by the *standard deviation*, usually abbreviated σ ; it is defined through

$$\sigma^2 = \frac{1}{n-1} \sum_{i=1}^n (x_i - \bar{x})^2 \quad (609)$$

- Challenge 646 where \bar{x} is the average of the measurements x_i . (Can you imagine why $n-1$ is used in the formula instead of n ?) By the way, for a gaussian distribution, 2.35σ is the full width at half maximum.

Lack of accuracy is due to *systematic errors*; usually they can only be estimated. This estimate is often added to the random errors to produce a *total experimental error*, sometimes also called *total uncertainty*.

Ref. 16 The following tables give the values of the most important physical constants and particle properties in SI units and in a few other common units, as published in the standard references. The values are the world average of the best measurements up to December 1998. As usual, experimental errors, including both random and estimated systematic errors, are expressed by giving the one standard deviation uncertainty in the last digits; e.g. 0.31(6)

Ref. 15 * It is not a joke however, that owners of several apple trees in Britain and in the US claim descentance, by rerooting, from the original tree under which Newton had his insight. DNA tests have even been performed to decide if all these derive from the same tree, with the result that the tree at MIT, in contrast to the British ones, is a fake – of course.

means 0.31 ± 0.06 . In fact, behind each of the numbers in the following tables there is a long story which would be worth telling, but for which there is not enough room here. *

What are the limits to accuracy and precision? First of all, there is no way, even in principle, to measure a quantity x to a *precision* higher than about 61 digits, because $\Delta x/x \gtrsim l_{\text{Pl}}/d_{\text{horizon}} = 10^{-61}$. In the third part of our text, studies of clocks and meter bars will further reduce this theoretical limit.

See page 703

But it is not difficult to deduce more stringent practical limits. No reasonable machine can measure quantities with a higher precision than measuring the diameter of the earth within the smallest length ever measured, about 10^{-19} m; that makes about 26 digits. Using a more realistic limit of a 1000 m sized machine implies a limit of 22 digits. If, as predicted above, time measurements really achieve 17 digits of precision, then they are nearing the practical limit, because apart from size, there is an additional practical restriction: cost. Indeed, an additional digit in measurement precision means often an additional digit in equipment cost.

Basic physical constants

In principle, all experimental measurements of matter properties, such as colour, density, or elastic properties, can be predicted using the values of the following constants, using them in quantum theory calculations. Specifically, this is possible using the equations of the standard model of high energy physics.

Ref. 17

See page 626

Table 60 Basic physical constants

Quantity	name	value in SI units	uncertainty
vacuum speed of light ^a	c	299 792 458 m/s	0
vacuum number of space-time dimensions		3 + 1 down to 10^{-19} m, up to 10^{26} m	
vacuum permeability ^a	μ_0	$4\pi \cdot 10^{-7}$ H/m	0
		= 1.256 637 061 435 917 295 385 ... $\mu\text{H/m}$	
vacuum permittivity ^a	$\epsilon_0 = 1/\mu_0 c^2$	8.854 187 817 620 ... pF/m	0
Planck constant	h	$6.626 068 76(52) \cdot 10^{-34}$ Js	$7.8 \cdot 10^{-8}$
reduced Planck constant	\hbar	$1.054 571 596(82) \cdot 10^{-34}$ Js	$7.8 \cdot 10^{-8}$
positron charge	e	0.160 217 646 2(63) aC	$3.9 \cdot 10^{-8}$
Boltzmann constant	k	$1.380 650 3(24) \cdot 10^{-23}$ J/K	$1.7 \cdot 10^{-6}$
gravitational constant	G	$6.673(10) \cdot 10^{-11}$ Nm ² /kg ²	$1.5 \cdot 10^{-3}$
gravitational coupling constant	$\kappa = 8\pi G/c^4$	$2.076(3) \cdot 10^{-43}$ s ² /kg m	$1.5 \cdot 10^{-3}$
fine structure constant, ^b	$\alpha = \frac{e^2}{4\pi\epsilon_0\hbar c}$	1/137.035 999 76(50)	$3.7 \cdot 10^{-9}$
e.m. coupling constant	$= g_{\text{em}}(m_e^2 c^2)$	= 0.007 297 352 533(27)	$3.7 \cdot 10^{-9}$
Fermi coupling constant, ^b	$G_{\text{F}}/(\hbar c)^3$	$1.166 39(1) \cdot 10^{-5}$ GeV ⁻²	$8.6 \cdot 10^{-6}$
weak coupling constant	$\alpha_{\text{w}}(M_{\text{Z}}) = g_{\text{w}}^2/4\pi$	1/30.1(3)	
weak mixing angle	$\sin^2 \theta_{\text{W}}(\overline{MS})$	0.231 24(24)	$1.0 \cdot 10^{-3}$
weak mixing angle	$\sin^2 \theta_{\text{W}}$ (on shell)	0.2224(19)	$8.7 \cdot 10^{-3}$
	$= 1 - (m_{\text{W}}/m_{\text{Z}})^2$		
strong coupling constant ^b	$\alpha_{\text{s}}(M_{\text{Z}}) = g_{\text{s}}^2/4\pi$	0.118(3)	$25 \cdot 10^{-3}$

* Some of them can be found in the text by N. W. WISE, *The Values of Precision*, Princeton University Press, 1994. The field of high precision measurements, from which the results on these pages stem, is a very special world. A beautiful introduction to it is *Near Zero: Frontiers of Physics*, edited by J.D. FAIRBANKS, B.S. DEEVER, C.W. EVERITT & P.F. MICHAELSON, Freeman, 1988.

a. Defining constant.

b. All coupling constants depend on the four-momentum transfer, as explained in the section on renormalization. *Fine structure constant* is the traditional name for the electromagnetic coupling constant g_{em} in the case of a four momentum transfer of $Q^2 = m_e^2 c^2$, which is the smallest one possible. At higher momentum transfers it has larger values, e.g. $g_{em}(Q^2 = M_W^2 c^2) \approx 1/128$. The strong coupling constant has higher values at lower momentum transfers; e.g. one has $\alpha_s(34 \text{ GeV}) = 0.14(2)$.

Why do all these constants have the values they have? The answer depends on the constant. For any constant having a unit, such as the quantum of action \hbar , the numerical value has no intrinsic meaning. It is $1.054 \cdot 10^{-34} \text{ Js}$ because of the SI definition of the joule and the second.

However, the question why the value of a constant with units is not larger or smaller always requires to understand the origin of some dimensionless number. For example, \hbar , G and c are not smaller or larger because the everyday world, in basic units, is of the dimensions we observe. The same happens if we asks about the size of atoms, people, trees and stars, about the duration of molecular and atomic processes, or about the mass of nuclei and mountains. Understanding the values of all dimensionless constants is thus the key to understanding nature.

The basic constants yield the following useful high-precision observations.

Table 61 Derived physical constants

Quantity	name	value in SI units	uncertainty
Vacuum wave resistance	$Z_0 = \sqrt{\mu_0/\epsilon_0}$	376.730 313 461 77... Ω	0
Avogadro's number	N_A	$6.022 141 99(47) \cdot 10^{23}$	$7.9 \cdot 10^{-8}$
Rydberg constant ^a	$R_\infty = m_e c \alpha^2 / 2h$	10973 731.568 549(83) m^{-1}	$7.6 \cdot 10^{-12}$
mag. flux quantum	$\Phi_0 = h/2e$	2.067 833 636(81) pWb	$3.9 \cdot 10^{-8}$
Josephson freq. ratio	$2e/h$	483.597 898(19) THz/V	$3.9 \cdot 10^{-8}$
von Klitzing constant	$h/e^2 = \mu_0 c / 2\alpha$	25 812.807 572(95) Ω	$3.7 \cdot 10^{-9}$
Bohr magneton	$\mu_B = e\hbar/2m_e$	$9.274 008 99(37) \cdot 10^{-24} \text{ J/T}$	$4.0 \cdot 10^{-8}$
classical electron radius	$r_e = e^2/4\pi\epsilon_0 m_e c^2$	2.817 940 285(31) fm	$1.1 \cdot 10^{-8}$
Compton wavelength of the electron	$\lambda_c = h/m_e c$	2.426 310 215(18) pm	$7.3 \cdot 10^{-9}$
	$\tilde{\lambda}_c = \hbar/m_e c = r_e/\alpha$	0.386 159 264 2(28) pm	$7.3 \cdot 10^{-9}$
Bohr radius ^a	$a_\infty = r_e/\alpha^2$	52.917 720 83(19) pm	$3.7 \cdot 10^{-9}$
cyclotron frequency of the electron	$f_c/B = e/2\pi m_e$	27.992 4925(11) GHz/T	$4.0 \cdot 10^{-8}$
nuclear magneton	$\mu_N = e\hbar/2m_p$	$5.050 783 17(20) \cdot 10^{-27} \text{ J/T}$	$4.0 \cdot 10^{-8}$
proton electron mass ratio	m_p/m_e	1 836.152 667 5(39)	$2.1 \cdot 10^{-9}$
Stephan-Boltzmann constant	$\sigma = \pi^2 k^4 / 60 \hbar^3 c^2$	$5.670 400(40) \cdot 10^{-8} \text{ W/m}^2 \text{ K}^4$	$7.0 \cdot 10^{-6}$
Wien displacement law constant	$b = \lambda_{\max} T$	2.897 7686(51) mmK	$1.7 \cdot 10^{-6}$
bits to entropy conv. const.		$10^{23} \text{ bit} = 0.956 994 5(17) \text{ J/K}$	
TNT energy content		4.2 GJ/ton	

a. For infinite mass of the nucleus.

Some properties of the universe as a whole are listed in the following.

Table 62 Astrophysical constants

Quantity	name	value
gravitational constant	G	$6.672\,59(85) \cdot 10^{-11} \text{ m}^3/\text{kg s}^2$
cosmological constant	Λ	ca. $1 \cdot 10^{-52} \text{ m}^{-2}$
tropical year 1900 ^{<i>a</i>}	a	31 556 925.9747 s
tropical year 1994	a	31 556 925.2 s
mean sidereal day	d	$23^{\text{h}}56^{\text{m}}4.090\,53^{\text{s}}$
astronomical unit ^{<i>b</i>}	AU	149 597 870.691(30) km
light year	al	9.460 528 173 ... Pm
parsec	pc	30.856 775 806 Pm = 3.261 634 al
age of the universe ^{<i>c</i>}	t_0	$> 3.5(4) \cdot 10^{17} \text{ s}$ or $> 11.5(1.5) \cdot 10^9 \text{ a}$ (from matter, via galaxies and stars, using quantum theory: early 1997 results)
age of the universe ^{<i>c</i>}	t_0	$4.7(1.5) \cdot 10^{17} \text{ s} = 13.5(1.5) \cdot 10^9 \text{ a}$ (from space-time, via expansion, using general relativity)
universe's horizon's dist. ^{<i>c</i>}	$d_0 = 3ct_0$	$5.2(1.4) \cdot 10^{26} \text{ m} = 13.8(4.5) \text{ Gpc}$
universe's topology		unknown
number of space dimensions		3
Hubble parameter ^{<i>c</i>}	H_0	$2.2(1.0) \cdot 10^{-18} \text{ s}^{-1} = 0.7(3) \cdot 10^{-10} \text{ a}^{-1}$ $= h_0 \cdot 100 \text{ km/sMpc} = h_0 \cdot 1.0227 \cdot 10^{-10} \text{ a}^{-1}$
reduced Hubble par. ^{<i>c</i>}	h_0	$0.59 < h_0 < 0.7$
critical density of the universe	$\rho_c = 3H_0^2/8\pi G$	$h_0^2 \cdot 1.878\,82(24) \cdot 10^{-26} \text{ kg/m}^3$
density parameter ^{<i>c</i>}	$\Omega_{\text{M}_0} = \rho_0/\rho_c$	ca. 0.3
luminous matter density		ca. $2 \cdot 10^{-28} \text{ kg/m}^3$
stars in the universe	n_s	$10^{22\pm 1}$
baryons in the universe	n_b	$10^{81\pm 1}$
baryon mass	m_b	$1.7 \cdot 10^{-27} \text{ kg}$
baryon number density		1 to 6 /m ³
photons in the universe	n_γ	10^{89}
photon energy density	$\rho_\gamma = \pi^2 k^4/15T_0^4$	$4.6 \cdot 10^{-31} \text{ kg/m}^3$
photon number density		$400/\text{cm}^3 (T_0/2.7 \text{ K})^3$, at present 410.89/cm ³
background temperature ^{<i>d</i>}	T_0	2.726(5) K
Planck length	$l_{\text{Pl}} = \sqrt{\hbar G/c^3}$	$1.62 \cdot 10^{-35} \text{ m}$
Planck time	$t_{\text{Pl}} = \sqrt{\hbar G/c^5}$	$5.39 \cdot 10^{-44} \text{ s}$
Planck mass	$m_{\text{Pl}} = \sqrt{\hbar c/G}$	21.8 μg
instants in history ^{<i>c</i>}	t_0/t_{Pl}	$8.7(2.8) \cdot 10^{60}$
space-time points inside the horizon ^{<i>c</i>}	$N_0 = (R_0/l_{\text{Pl}})^3 \cdot (t_0/t_{\text{Pl}})$	$10^{244\pm 1}$
mass inside horizon	M	$10^{54\pm 1} \text{ kg}$

a. Defining constant, from vernal equinox to vernal equinox; it was once used to define the second. (Remember: π seconds is a nanocentury.) The value for 1990 is about 0.7 s less, corresponding to a slowdown of roughly -0.2 ms/a . There is even an empirical formula available for the change of the

Challenge 663

Ref. 18 length of the year over time.

b. Average distance earth-sun. The truly amazing precision of 30 m results from time averages of signals sent from Viking orbiters and Mars landers taken over a period of over twenty years.

c. The index o indicates present day values.

d. The radiation originated when the universe was between 10^5 to 10^6 years old and about 3000 K hot; the fluctuations ΔT_o which lead to galaxy formation are today of the size of $16 \pm 4 \mu\text{K} = 6(2) \cdot 10^{-6} T_o$.

See page 287

Attention: in the third part of this text it is shown that many constants in Table 62 are *not* physically sensible quantities. They have to be taken with lots of grains of salt. The more specific constants given in the following table are all sensible though.

Table 63 Astronomical constants

Quantity	name	value
earth's mass	M	$5.97223(8) \cdot 10^{24}$ kg
earth's gravitational length	$l = 2GM/c^2$	8.870(1) mm
earth radius, equatorial ^a	R_{eq}	6378.1367(1) km
earth radius, polar ^a	R_p	6356.7517(1) km
equator pole distance ^a		10 001.966 km (average)
earth flattening ^a	e	1/298.25231(1)
moon's radius	R_{mv}	1738 km in direction of earth
moon's radius	R_{mh}	17.. km in perpendicular direction
moon's mass	M_m	$7.35 \cdot 10^{22}$ kg
moon's mean distance ^b	d_m	384401 km
moon's perigeon		typically 363 Mm, hist. minimum 359861 km
moon's apogee		typically 404 Mm, hist. maximum 406720 km
moon's angular size ^c		avg. $0.5181^\circ = 31.08'$, min. 0.49° , max. 0.55°
sun's mass	M_\odot	$1.98843(3) \cdot 10^{30}$ kg
sun's grav. length	$l_\odot = 2GM_\odot/c^2$	2.95325008 km
sun's luminosity	L_\odot	384.6 YW
solar radius, equatorial	R_\odot	695.98(7) Mm
sun's angular size		0.53° average
sun's distance, average	AU	149597870.691(30) km
solar velocity	$v_{\odot g}$	220(20) km/s
around centre of galaxy		
solar velocity	$v_{\odot b}$	370.6(5) km/s
against cosmic background		
distance to galaxy centre		8.0(5) kpc = 26.1(1.6) kal
most distant galaxy	0140+326RD1	$12.2 \cdot 10^9$ al = $1.2 \cdot 10^{26}$ m, redshift 5.34

a. The shape of the earth is described most precisely with the World Geodetic System. The last edition dates from 1984. For an extensive presentation of its background and its details, see the <http://www.eurocontrol.be/projects/eatchip/wgs84/start.html> web site. The International Geodesic Union has refined the data in 2000. The radii and the flattening given here are those for the 'mean tide system'. They differ from those of the 'zero tide system' and other systems by about 0.7 m. The details are a science by its own.

b. Measured centre to centre. To know the precise position of the moon at a given date, see the <http://www.fourmilab.ch/earthview/moon-ap-per.html> site, whereas for the planets see <http://www.fourmilab.ch/solar/solar.html> as well as the other pages on this site.

c. Angles are defined as follows: 1 degree = $1^\circ = \pi/180$ rad, 1 (first) minute = $1' = 1^\circ/60$, 1 second (minute) = $1'' = 1'/60$. The ancient units ‘third minute’ and ‘fourth minute’, each 1/60th of the preceding, are not accepted any more. (‘Minute’ originally means ‘very small’, as it still does in modern English.)

Useful numbers

π	3.14159 26535 89793 23846 26433 83279 50288 41971 69399 37510 ₅
e	2.71828 18284 59045 23536 02874 71352 66249 77572 47093 69995 ₉
γ	0.57721 56649 01532 86060 65120 90082 40243 10421 59335 93992 ₃
$\ln 2$	0.69314 71805 59945 30941 72321 21458 17656 80755 00134 36025 ₅
$\ln 10$	2.30258 50929 94045 68401 79914 54684 36420 76011 01488 62877 ₂
$\sqrt{10}$	3.16227 76601 68379 88935 44432 71853 37195 55139 32521 68268 ₅

Ref. 19

If the number π were *normal*, i.e. if all digits and digit combinations would appear with the same probability, then every text written or to be written, as well as every word spoken or to be spoken, can be found coded in its sequence. The property of normality has not yet been proven, even though it is suspected to be true. What is the significance? Is all wisdom encoded in the simple circle? No. The property is nothing special, as it also applies to the number 0.123456789101112131415161718192021... and many others. Can you specify a few?

Challenge 680



References

- 1 *Le Système International d'Unités*, Bureau International des Poids et Mesures, Pavillon de Breteuil, Parc de Saint Cloud, 92 310 Sèvres, France. All new developments concerning SI units are published in the journal *Metrologia*, edited by the same body. Showing the slow pace of an old institution, the BIPM was on the internet only in 1998; it is now reachable on its simple site at <http://www.bipm.fr>. The site of its British equivalent, http://www.npl.co.uk/npl/reference/si_units.html, is much better; it gives many other details as well as the English version of the SI unit definitions. Cited on page 811.
- 2 The bible in the field of time measurement are the two volumes by J. VANIER & C. AUDOIN, *The Quantum Physics of Atomic Frequency Standards*, Adam Hilge, 1989. A popular account is, *Splitting the Second*, 2000.
The site <http://opdaf1.obspm.fr/www/lexique.html> gives a glossary of terms used in the field. On length measurements, see ... On mass and atomic mass measurements, see page 193. The precision of mass measurements of solids is limited by such simple effects as the adsorption of water on the weight. Can you estimate what a monolayer of water does on a weight of 1 kg?
On electric current measurements, see ... On precision temperature measurements, see page 227. Cited on page 812.
- 3 The unofficial prefixes have been originally proposed in the 1990s by Jeff K. Aronson, professor at the University of Oxford, and are slowly coming into general usage. Cited on page 813.

Challenge 697

- 4 David J. BIRD & al., *Evidence for correlated changes in the spectrum and composition of cosmic rays at extremely high energies*, Physical Review Letters **71**, pp. 3401–3404, 1993. Cited on page 817.
- 5 Pertti J. HAKONEN & al., *Nuclear antiferromagnetism in Rhodium metal at positive and negative nanokelvin temperature*, Physical Review Letters **70**, pp. 2818–2821, 1993. See also his article in the Scientific American, January 1994. Cited on page 817.
- 6 See e.g. K. CODLING & L.J. FRASINSKI, *Coulomb explosion of simple molecules in intense laser fields*, Contemporary Physics **35**, pp. 243–255, 1994. Cited on page 817.
- 7 A. ZEILINGER, *The Planck stroll*, American Journal of Physics **58**, p. 103, 1990. Cited on page 817.
- 8 The most precise clock ever built is ... Cited on page 818.
- 9 J. BERGQUIST, editor, *Proceedings of the Fifth Symposium on Frequency Standards and Metrology*, World Scientific, 1997. Cited on page 818.
- 10 About short lifetime measurements, see e.g. the paper on D particle lifetime ... Cited on page 818.
- 11 About the long life of tantalum 180, see D. BELIC & al., *Photoactivation of $^{180}\text{Ta}^m$ and its implications for the nucleosynthesis of nature's rarest naturally occurring isotope*, Physical Review Letters **83**, pp. 5242–5245, 20 december 1999. Cited on page 818.
- 12 About the detection of gravitational waves, see ... Cited on page 818.
- 13 See the clear and extensive paper by G.E. STEDMAN, *Ring laser tests of fundamental physics and geophysics*, Reports on Progress of Physics **60**, pp. 615–688, 1997. Cited on page 818.
- 14 Following a private communication by Richard Rusby, this is the value of 1997, whereas it was estimated as 99.975 °C in 1989, as reported by GARETH JONES & RICHARD RUSBY, *Official: water boils at 99.975 °C*, Physics World, pp. 23–24, September 1989, and R.L. RUSBY, *Ironing out the standard scale*, Nature **338**, p. 1169, March 1989. For more on temperature measurements, see page 227. Cited on page 819.
- 15 See *Newton's apples fall from grace*, New Scientist, p. 5, 6 September 1996. More details can be found in R.G. KEESING, *The history of Newton's apple tree*, Contemporary Physics **39**, pp. 377–391, 1998. Cited on page 819.
- 16 The various concepts are even the topic of a separate international standard, ISO 5725, with the title *Accuracy and precision of measurement methods and results*. A good introduction is the book with the locomotive hanging out the window as title picture, namely JOHN R. TAYLOR, *An Introduction to Error Analysis: the Study of Uncertainties in Physical Measurements*, 2nd edition, University Science Books, Sausalito, 1997. Cited on page 819.
- 17 P.J. MOHR & B.N. TAYLOR, *Reviews of Modern Physics* **59**, p. 351, 2000. This is the set of constants resulting from an international adjustment and recommended for international use by the Committee on Data for Science and Technology (CODATA), a body in the International Council of Scientific Unions, which regroups the International Union of Pure and Applied Physics (IUPAP), the International Union of Pure and Applied Chemistry (IUPAC) and many more. The IUPAC has a horrible web site at <http://chemistry.rsc.org/rsc/iupac.htm>. Cited on page 819, 820.
- 18 The details are given in the well-known astronomical reference, P. KENNETH SEIDELMANN, *Explanatory Supplement to the Astronomical Almanac*, 1992. Cited on page 823.
- 19 For information about the number π , as well as about other constants, the web address <http://www.cecm.sfu.ca/pi/pi.html> provides lots of data and references. It also has a link to the pretty overview paper on <http://www.astro.virginia.edu/~eww6n/math/Pi.html> and to many other

sites on the topic. Simple formulas for π are

$$\pi + 3 = \sum_{n=1}^{\infty} \frac{n 2^n}{\binom{2n}{n}} \quad (610)$$

or the beautiful formula discovered in 1996 by Bailey, Borwein, and Plouffe

$$\pi = \sum_{n=0}^{\infty} \frac{1}{16^n} \left(\frac{4}{8n+1} - \frac{2}{8n+4} - \frac{1}{8n+5} - \frac{1}{8n+6} \right) . \quad (611)$$

The site also explains the newly discovered methods to calculate specific binary digits of π without having to calculate all the preceding ones. By the way, the number of (consecutive) digits known in 1999 was over 206 thousand million, as told in *Science News* **156**, p. 255, 16 October 1999. They pass all tests for a random string of numbers, as the http://www.ast.univie.ac.at/~wasi/PI/pi_normal.html web site explains. However, this property, called *normality*, has never been proven; it is the biggest open question about π . It is possible that the theory of chaotic dynamics will lead to a solution of this puzzle in the coming years.

Another method to calculate π and other constants was discovered and published by DAVID V. CHUDNOVSKY & GREGORY V. CHUDNOVSKY, *The computation of classical constants*, Proc. Natl. Acad. Sci. USA, volume 86, pp. 8178–8182, 1989. The Chudnowsky brothers have built a supercomputer in Gregory's apartment for about 70 000 \$, and for many years held the record for the largest number of digits for π . They battle already for decades with Kanada Yasumasa, who holds the record in 2000, calculated on an industrial supercomputer. New formulas to calculate π are still irregularly discovered.

For the calculation of Euler's constant γ see also D. W. DETEMPLE, *A quicker convergence to Euler's constant*, *The Mathematical Intelligencer*, pp. 468–470, May 1993.

Note that little is known about properties of numbers; e.g. it is still not known whether $\pi + e$ is a rational number or not! (It is believed that not.) Want to become a mathematician?

Cited on page 824.

Challenge 714



APPENDIX C PARTICLE PROPERTIES

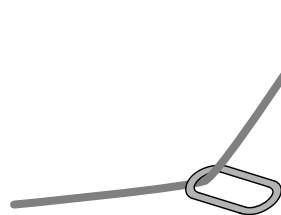

The following table gives the overview of the known and predicted elementary particles. There have been no changes in it since the mid 1970s.

Radiation	electromagnetic interaction	weak interaction	strong interaction
	γ	W^+ , W^- Z^0	g_1 .. g_8
	photon	intermediate vector bosons	gluons
	Radiation particles are bosons with spin 1. W^- is antiparticle of W^+ ; all others are their own antiparticles.		
Matter	generation 1	generation 2	generation 3
Leptons	e ν_e	μ ν_μ	τ ν_τ
Quarks (each in three colours)	u d	s c	t b
	Matter particles are fermions with spin 1/2; all have a corresponding antiparticle.		
Hypothetical matter and radiation			
Higgs boson	H	predicted to have spin 0 and to be elementary	
Supersymmetric partners	se ... h	one partner for each of the above	

Table 64 The elementary particles

The following table contains the *complete list of properties* of all elementary particles. The future should not change it much. * The header of this table therefore lists the *complete* set of properties, after the quantum number of colour is added, which characterize any particle. This list thus also allows to deduce a complete characterization of the intrinsic properties of any *composed* moving entity, be it an object or an image.

Table 65 Elementary particle properties

Particle name and symbol	mass m	lifetime τ or energy width, main decay modes	isospin I , spin J , parity P , charge Q , parity C	charge Q , isospin I , strangeness S , charm C , topness T , beauty B	lepton number L , baryon number B , R -parity
elementary radiation (bosons)					
photon γ	0 ($< 6 \cdot 10^{-16} \text{ eV}/c^2$)	stable	$I(J^{PC}) = 0, 1(1^{--})$	000 000	0, 0, 1
W^\pm	80.75(64) GeV/ c^2	2.06(6) GeV 67.8(1.0)% hadrons, 32.1(2,0)% $l^+\nu$	$J = 1$	$\pm 100\ 000$	0, 0, 1
Z	91.187(7) GeV/ c^2	2.65(1) $\cdot 10^{-25}$ s 69.90(15)% hadrons	$J = 1$	000 000	0, 0, 1
gluon	0	stable	$I(J^P) = 0(1^-)$	000 000	0, 0, 1
elementary matter (fermions): leptons					
electron e	9.109 381 88(72) $\cdot 10^{-31}$ kg = 81.871 0414(64) pJ/ c^2 = 0.510 998 902(21) MeV/ c^2 = 0.000 548 579 911 0(12) u gyromagnetic ratio $g = \mu_e/\mu_B = -1.001\ 159\ 652\ 1869(41)$ electric dipole moment $d = (-0.3 \pm 0.8) \cdot 10^{-29} e \text{ m}$	$> 13 \cdot 10^{30}$ s	$J = \frac{1}{2}$	-100 000	1, 0, 1
muon μ	0.188 353 109(16) yg = 105.658 3568(52) MeV/ c^2 = 0.113 428 9168(34) u gyromagnetic ratio $g = \mu_\mu/(e\hbar/2m_\mu) = -1.001\ 165\ 91602(64)$ electric dipole moment $d = (3.7 \pm 3.4) \cdot 10^{-22} e \text{ m}$	2.197 03(4) μs 99% $e^-\bar{\nu}_e\nu_\mu$	$J = \frac{1}{2}$	-100 000	1, 0, 1
tau τ	1.777 05(29) GeV/ c^2	290.0(1.2) fs	$J = \frac{1}{2}$	-100 000	1, 0, 1
el. neutrino ν_e	$< 7.2 \text{ eV}/c^2$		$J = \frac{1}{2}$		1, 0, 1
muon neutrino ν_μ	$< 0.17 \text{ MeV}/c^2$		$J = \frac{1}{2}$		1, 0, 1
tau neutrino ν_τ	$< 24 \text{ MeV}/c^2$		$J = \frac{1}{2}$		1, 0, 1
elementary matter (fermions): quarks					

* The official reference for all this data, worth a look by every physicist, is the massive collection by the particle data group, with the web site <http://pdg.web.cern.ch/pdg> containing the most recent information.

A printed review is published about every two years with updated data in one of the large journals on elementary particle physics. See for example C. CASO & al., The European Physical Journal C **3**, p. 1, 1998. For measured properties of these particles, the official reference is the set of CODATA values. The most recent list was published by P.J. MOHR & B.N. TAYLOR, Reviews of Modern Physics **59**, p. 351, 2000.

Particle name and symbol	mass m	lifetime τ or energy width, main decay modes	isospin I , spin J , parity P , charge C	charge Q , isospin I , strangeness S , charm C , topness T , beauty B	lepton number L , baryon number B , R -parity
up quark u	$1.5 - 5 \text{ MeV}/c^2$	see proton	$I(J^P) = \frac{1}{2}(\frac{1}{2}^+)$	$-\frac{1}{3} - \frac{1}{2}0000$	$0, 1/3, 1$
down quark d	$3 - 9 \text{ MeV}/c^2$	see proton	$I(J^P) = \frac{1}{2}(\frac{1}{2}^+)$	$\frac{2}{3}\frac{1}{2}0000$	$0, 1/3, 1$
strange quark s	$60 - 170 \text{ MeV}/c^2$		$I(J^P) = 0(\frac{1}{2}^+)$	$-\frac{1}{3}0 - 1000$	$0, 1/3, 1$
charm quark c	$1.25(15) \text{ GeV}/c^2$		$I(J^P) = 0(\frac{1}{2}^+)$	$\frac{2}{3}00 + 100$	$0, 1/3, 1$
bottom quark b	$4.25(15) \text{ GeV}/c^2$	$\tau = 1.33(11) \text{ ps}$	$I(J^P) = 0(\frac{1}{2}^+)$	$-\frac{1}{3}000 - 10$	$0, 1/3, 1$
top quark t	$173.8(5.2) \text{ GeV}/c^2$		$I(J^P) = 0(\frac{1}{2}^+)$	$\frac{2}{3}0000 + 1$	$0, 1/3, 1$
hypothetical, maybe elementary (boson)					
Higgs* H	$135(20) \text{ GeV}/c^2$		$J = 0$		
hypothetical elementary radiation (bosons)					
Selectron*			$J = 0$		$R = -1$
Smuon*			$J = 0$		$R = -1$
Stauon*			$J = 0$		$R = -1$
Sneutrinos*			$J = 0$		$R = -1$
Squark*			$J = 0$		$R = -1$
hypothetical elementary matter (fermions)					
Higgsino(s)*			$J = \frac{1}{2}$		$R = -1$
Wino* (a chargino)			$J = \frac{1}{2}$		$R = -1$
Zino* (a neutralino)			$J = \frac{1}{2}$		$R = -1$
Photino*			$J = \frac{1}{2}$		$R = -1$
Gluino*			$J = \frac{1}{2}$		$R = -1$

Notes:

* Presently a hypothetical particle.

■ To keep the table short, the header does not explicitly mention *colour*, the charge of the strong interactions. It has to be added to the list of object properties.

Ref. 1 ■ The electron radius is below 10^{-22} m .

Ref. 2 ■ It is possible to store single electrons in traps for many months.

■ See also the table of SI prefixes on page 812. About the eV/c^2 mass unit, see page 816.

■ Quantum numbers containing the word ‘parity’ are multiplicative; all others are additive.

■ Time parity T , better called motion inversion parity, is equal to CP.

■ The isospin I or I_Z is defined only for up and down quarks and their composites, such as the proton and the neutron. In the literature one also sees references to the so-called G-parity, defined as $G = (-1)^{IC}$.

■ R -parity is a quantum number important in supersymmetric theories; it is related to the lepton number L , the baryon number B and the spin J through the definition $R = (-1)^{3B+L+2J}$. All particles from the standard model are R -even, whereas their superpartners are odd.

■ The sign of the quantum numbers I_Z, S, C, B, T can be defined in different ways. In the standard assignment shown here, the sign of each of the non-vanishing quantum numbers is given by the sign of the charge of the corresponding quark.

- There is a difference between the half-life $t_{1/2}$ and the lifetime τ of a particle; the *half-life* is given by $t_{1/2} = \tau \ln 2$, where $\ln 2 \approx 0.693\,147\,18$, and is thus shorter than the lifetime. The *energy width* Γ of a particle is related to its lifetime τ by the uncertainty relation $\Gamma\tau = \hbar$.
- The unified *atomic mass unit* is defined as $(1/12)$ of the mass of an Carbon atom of the isotope ^{12}C at rest and in its ground state. One has $1\text{ u} = \frac{1}{12}m(^{12}\text{C}) = 1.660\,5402(10)\text{ yg}$.
- See page 615 for the precise definition and meaning of the quark masses.
- The electric polarizability is defined on page 381; it is predicted to vanish for all elementary particles.

Using the table of elementary particle properties, together with the standard model and the fundamental constants, in principle *all* properties of composite matter and radiation can be deduced, including all those encountered in everyday life. (Can you explain how the size of an object follows from them?) In a sense, this table contains the complete results of the study of matter and radiation, such as material science, chemistry, and biology.

Challenge 748

The most important examples of composites are grouped in the following table.

Table 66 Properties of selected composites

Composite	mass m , quantum numbers	lifetime τ , main decay modes	size (diameter)
mesons (hadrons, bosons) out of the over 130 types known			
pion $\pi^0(\text{u}\bar{\text{u}} - \text{d}\bar{\text{d}})/\sqrt{2}$	134.9764(6) MeV/ c^2 $I^G(J^{PC}) = 1^-(0^{-+}), S = C = B = 0$	84(6) as, 2γ 98.798(32)%	~ 1 fm
pion $\pi^+(\text{u}\bar{\text{d}})$	139.56995(35) MeV/ c^2 $I^G(J^P) = 1^-(0^-), S = C = B = 0$	26.030(5) ns, $\mu^+\nu_\mu$ 99.9877(4)%	~ 1 fm
kaon K_S^0	$m_{K_S^0}$	89.27(9) ps	
kaon K_L^0	$m_{K_S^0} + 3.491(9)\mu\text{eV}/c^2$	51.7(4) ns	
kaon $K^\pm(\text{u}\bar{\text{s}}, \bar{\text{u}}\text{s})$	493.677(16) MeV/ c^2	12.386(24) ns, $\mu^+\nu_\mu$ 63.51(18)% 21.16(14)% $\pi^+\pi^0$	
kaon $K^0(\text{d}\bar{\text{s}})$ (50% K_S , 50% K_L)	497.672(31) MeV/ c^2	n.a.	~ 1 fm
kaons K^\pm, K^0, K_S^0, K_L^0	$I(J^P) = \frac{1}{2}(0^-), S = \pm 1, B = C = 0$		
baryons (hadrons, fermions) out of the over 100 types known			
proton p or N^+ (uud)	1.67262158(13) yg $= 1.00727646688(13)\text{ u}$ $= 938.271998(38)\text{ MeV}/c^2$ $I(J^P) = \frac{1}{2}(\frac{1}{2}^+), S = 0$ gyromagnetic ratio $\mu_p/\mu_N = 2.792847337(29)$ electric dipole moment $d = (-4 \pm 6) \cdot 10^{-26}e\text{ m}$ electric polarizability $\alpha = 12.1(0.9) \cdot 10^{-4}\text{ fm}^3$ magnetic polarizability $\alpha = 2.1(0.9) \cdot 10^{-4}\text{ fm}^3$	$\tau_{\text{total}} > 1.6 \cdot 10^{25}\text{ a}$, $\tau(p \rightarrow e^+\pi^0) > 5.5 \cdot 10^{32}\text{ a}$	0.89(1) fm Ref. 3
neutron n or N^0 (udd)	1.67492716(13) yg $= 1.00866491578(55)\text{ u}$ $= 939.565330(38)\text{ MeV}/c^2$ $I(J^P) = \frac{1}{2}(\frac{1}{2}^+), S = 0$ gyromagnetic ratio $\mu_n/\mu_N = -1.91304272(45)$ electric dipole moment $d_n = (-3.3 \pm 4.3) \cdot 10^{-28}e\text{ m}$	887.0(2.0) s, $p e^- \bar{\nu}_e$ 100 %	~ 1 fm

Composite	mass m , quantum numbers	lifetime τ , main decay modes	size (diameter)
omega Ω^- (sss)	electric polarizability $\alpha = 0.98(23) \cdot 10^{-3} \text{ fm}^3$ 1672.43(32) MeV/ c^2	82.2(1.2) ps, ΛK^- 67.8(7)%, $\Xi^0 \pi^-$ 23.6(7)% gyromagnetic ratio $\mu_\Omega/\mu_N = -1.94(22)$	$\sim 1 \text{ fm}$
composite radiation: glueballs			
glueball $f_0(1500)$	1503(11) MeV $I^G(J^{PC}) = 0^+(0^{++})$	full width 120(19) MeV	$\sim 1 \text{ fm}$
atoms out of the 115 known elements with over 2000 known isotopes Ref. 4			
hydrogen (^1H) [lightest] antihydrogen	1.007 825 032(1) u = 1.6735 yg		2...pm
helium (^4He) [smallest]	4.002 603250(1) u = 6.6465 yg		2·32 pm
carbon (^{12}C)	12 u = 19.926482(12) yg		2·77 pm
bismuth $^{209}_{83}\text{Bi}$ [shortest living and rarest]	209 u	0.1 ps	
tantalum ^{180}Ta [longest living radioactive]	180 u	$> 10^{15} \text{ a}$ Ref. 5	
francium [largest of all]	223 u	...	2·0.24 nm
atom 116 [heaviest of all]	289 u	...	
molecules out of the over 10^7 known types			
hydrogen (H_2)	$\sim 2 \text{ u}$	$> 10^{25} \text{ a}$	
water (H_2O)	$\sim 18 \text{ u}$	$> 10^{25} \text{ a}$	
ATP (adenosinetriphosphate)	360 u	$> 10^{10} \text{ a}$	ca. 3 nm
human Y chromosome	... ag	$> 10^6 \text{ a}$	ca. 50 mm
other composites			
whale nerve cell	$\sim 100 \text{ g}$	$\sim 50 \text{ a}$	20 m
cell (red blood)	1 ng	4-100 days	$\sim 10 \mu\text{m}$
cell (sperm)	10 pg	not fecundated: $\sim 5 \text{ d}$	length 60 μm , head 3 μm times 5 μm $\sim 120 \mu\text{m}$
cell (ovule)	1 μg	fecundated: over 4000 million years	$\sim 120 \mu\text{m}$
cell (E. Coli)	1 pg	4000 million years	body: 2 μm
adult human	35 kg $< m < 350 \text{ kg}$	$\tau \approx 2.5 \cdot 10^9 \text{ s}$ Ref. 6 ≈ 600 million breaths ≈ 2500 million heartbeats $\lesssim 122 \text{ a}$, 60% H_2O and 40% dust	$\sim 1.7 \text{ m}$
largest living thing	10 ⁵ kg	ca. 1000 a	$\sim 1 \text{ km}$

larger composites see table on page 124.

Notes (see also those of the previous table)

This is a section of the freely downloadable e-textbook

Motion Mountain

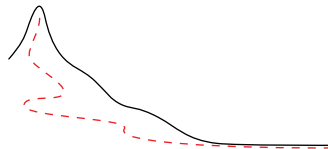

Hiking beyond space and time along the concepts of modern physics

available at
www.motionmountain.org

Copyright © 1997, 1998, 1999, 2000, 2001, 2002 by Christoph Schiller

To the kind reader

In exchange for getting this section for free, I ask you for a short email on some of the following:

- Which page was boring?
- Did you find any mistakes?
- What else were you expecting?
- What was hard to understand?

Of course, any other suggestion is welcome. This section is part of a physics text written over many years. The text lives and grows through the feedback from its readers, who help to improve and to complete it. For a particularly useful contribution (send it in english, italian, dutch, german, spanish, portuguese, or french) you will be mentioned in the foreword of the text, or receive a small reward, or both.

Enjoy!

Christoph Schiller
cs@motionmountain.org

Challenge 731

- G parity is defined only for mesons and given by $G = (-1)^{L+S+I} = (-1)^I \cdot C$.
- Neutrons bound in nuclei have a lifetime of at least 10^{20} years.
- The $f_0(1500)$ resonance is now accepted as a glueball and thus as a *radiation composite* by the high energy community, as announced at the HEO conference in Warsaw in 1996.
- The number of existing molecules is several orders of magnitude larger than the number of analysed and listed molecules.
- Some nuclei are not yet discovered; in 2002 the known nuclei range from 1 to 116, but 113, 115 and 117 are still missing.
- The first *anti-atoms*, made of antielectrons and antiprotons, have been made in January 1996 at CERN in Geneva. All properties for antimatter checked so far are consistent with the predictions.
- The charge parity C is defined only for certain neutral particles, namely those which are different from their antiparticles. For neutral mesons the charge parity is given by $C = (-1)^{L+S}$, where L is the orbital angular momentum.
- P is the parity under space inversion $\mathbf{r} \rightarrow -\mathbf{r}$. For mesons, it is connected through $P = (-1)^{L+1}$ with the orbital angular momentum L .

The most important matter composites are the *atoms*. Their size, structure and interactions determine the properties and colour of everyday objects. Atom types, also called *elements* in chemistry, are most efficiently grouped in the so-called *periodic table*, in which atoms behaving similarly are neighbours.

Group	1	2	3	4	5	6	7	8	9	10	11	12	13	14	15	16	17	18
	I	II	IIIa	IVa	Va	VIa	VIIa	VIIIa		IIa	III	IV	V	VI	VII	VIII		
Period																		
1	1 H																	2 He
2	3 Li	4 Be											5 B	6 C	7 N	8 O	9 F	10 Ne
3	11 Na	12 Mg											13 Al	14 Si	15 P	16 S	17 Cl	18 Ar
4	19 K	20 Ca	21 Sc	22 Ti	23 V	24 Cr	25 Mn	26 Fe	27 Co	28 Ni	29 Cu	30 Zn	31 Ga	32 Ge	33 As	34 Se	35 Br	36 Kr
5	37 Rb	38 Sr	39 Y	40 Zr	41 Nb	42 Mo	43 Tc	44 Ru	45 Rh	46 Pd	47 Ag	48 Cd	49 In	50 Sn	51 Sb	52 Te	53 I	54 Xe
6	55 Cs	56 Ba	*	72 Hf	73 Ta	74 W	75 Re	76 Os	77 Ir	78 Pt	79 Au	80 Hg	81 Tl	82 Pb	83 Bi	84 Po	85 At	86 Rn
7	87 Fr	88 Ra	**	104 Rf	105 Db	106 Sg	107 Bh	108 Hs	109 Mt	110 Uun	111 Uuu	112 Uub	113	114 Uuq	115	116 Uuh	117	118
Lanthanoids	*	57 La	58 Ce	59 Pr	60 Nd	61 Pm	62 Sm	63 Eu	64 Gd	65 Tb	66 Dy	67 Ho	68 Er	69 Tm	70 Yb	71 Lu		
Actinoids	**	89 Ac	90 Th	91 Pa	92 U	93 Np	94 Pu	95 Am	96 Cm	97 Bk	98 Cf	99 Es	100 Fm	101 Md	102 No	103 Lr		

Table 67 Periodic table of the elements known in 2002, with their atomic numbers

The atomic number gives the number of protons and of electrons found in an atom of a given element. This number also specifies each element in its chemical behaviour. Most elements up to around 92 are found in nature; the others are artificially produced in the laboratories. The last element discovered is element 116.

Elements in the same *group* behave similarly in chemical reactions. The *periods* define the repetition of these similarities. Extensive physical and chemical data is available for every element. More elaborate periodic tables can be found on the chemlab.pc.maricopa.edu/periodic/stowetable.html web site.

Ref. 9

Group 1 are the alkali metals, group 2 the earth-alkali metals. Actinoids, lanthanoids, and groups 3 to 13 are metals; in particular, groups 3 to 12 are heavy metals. The elements of group 16 are called *chalcogens*, i.e. ore-formers; group 17 are the *halogens*, i.e. the salt-formers, and group 18 are the *noble gases*, which do not form (almost) any chemical compounds. Groups 13, 14 and 15 contain metals, semimetals, liquids, and gases; they are of importance for the appearance of life.

Many elements exist in versions with different numbers of neutrons in their nucleus and thus with different mass; these various *isotopes* – called this way because they are found on the *same place* in the periodic table – behave identically in chemical reactions. There are over 2000 of them.

Ref. 4, 8

Table 68 The elements and their main properties

Name	sym- bol	at. num.	average mass ^a in u (with error) and longest lifetime	atomic ^e radius in pm	main properties (naming) use, and discovery date
Actinium ^b	Ac	89	(227.0277(1)) 21.77(2) a	n.a.	radioactive metal (Greek 'aktis' ray) 1899
Aluminium	Al	13	26.981 538(2) stable		light metal (Latin 'alumen' ...) 1827
Americium ^b	Am	95	(243.0614(1)) 7.37(2) ka	n.a.	radioactive metal (Italian 'America') 1945
Antimony	Sb	51	121.760(1) ^f stable		semimetal (via Arabic from Latin stibium, itself from Greek, Egyptian for one of its minerals) colours rubber, used in medicines, constituent of en- zymes
Argon	Ar	18	39.948(1) ^f stable	98	noble gas, (Greek 'argos' inactive from 'anergos' without energy) 1894, third component of air, used for weld- ing, in lasers
Arsenic	As	33	74.921 60(2) stable		semimetal (Greek 'arsenikon' tamer of males) antiquity, for poisoning pi- geons and doping semiconductors
Astatine ^b	At	85	(209.9871(1)) 8.1(4) h		radioactive halogen, (Greek 'astatos' unstable) 1940, no use
Barium	Ba	56	137.327(7) stable		(Greek 'bary' heavy) 1808
Berkelium ^b	Bk	97	(247.0703(1)) 1.4(3) ka	n.a.	(Berkeley, US town) 1949
Beryllium	Be	4	9.012 182(3) stable	112	(Greek 'beryllos', a mineral) 1797
Bismuth	Bi	83	208.980 38(2) stable		(Latin via German 'weisse Masse' white mass) 1753
Bohrium ^b	Bh	107	(264.12(1)) 0.44 s ^g	n.a.	(after Niels Bohr) 1981
Boron	B	5	10.811(7) ^f stable		(Latin borax, from Arabic and Persian for brilliant) 1808
Bromine	Br	35	79.904(1) stable		(Greek 'bromos' strong odour) 1826
Cadmium	Cd	48	112.411(8) ^f stable		(Greek kadmeia, a mineral) 1817
Caesium	Cs	55	132.905 45(2) stable		(Latin 'caesius' sky blue) 860
Calcium	Ca	20	40.078(4) ^f stable		(Latin 'calcis' chalk)
Californium ^b	Cf	98	(251.0796(1)) 0.90(5) ka	n.a.	(Latin 'calor' heat and 'fornicare' have sex, the land of hot sex) 1950
Carbon	C	6	12.0107(8) ^f stable		(Latin 'carbo' coal)

Name	sym- bol	at. num.	average mass ^a in u (with error) and longest lifetime	atomic ^e radius in pm	main properties (naming) use, and discovery date
Cerium	Ce	58	140.116(1) ^f stable		(after asteroid Ceres, roman goddess) 1803
Chlorine	Cl	17	35.453(2) ^f stable		green gas (Greek 'chloros' yellow- green) 1774
Chromium	Cr	24	51.9961(6) stable		(Greek 'chromos' colour) 1797
Cobalt	Co	27	58.933 200(9) stable		(German 'Kobold' goblin) 1694; part of vitamin B ₁₂
Copper	Cu	29	63.546(3) ^f stable		(Latin cuprum from Cyprus island) an- tiquity, part of many enzymes
Curium ^b	Cm	96	(247.0704(1)) 15.6(5) Ma	n.a.	(after Pierre and Marie Curie) 1944
Dubnium ^b	Db	105	(262.1141(1)) 34(5) s	n.a.	('Dubna' Russian city) 1967
Dysprosium	Dy	66	162.50(3) ^f stable		(Greek 'dysprositos' difficult to ob- tain) 1886
Einsteinium ^b	Es	99	(252.0830(1)) 472(2) d	n.a.	(after Albert Einstein) 1952
Erbium	Er	68	167.259(3) ^f stable		('Ytterby' Swedish town) 1843
Europium	Eu	63	151.964(1) ^f stable		1901, used in red tv screen colour
Fermium ^b	Fm	100	(257.0901(1)) 100.5(2) d	n.a.	(after Enrico Fermi) 1952
Fluorine	F	9	18.998 4032(5) stable		(from flourine, a mineral, from Greek 'fluo' flow) 1886
Francium ^b	Fr	87	(223.0197(1)) 22.0(1) min		(from France) 1939
Gadolinium	Gd	64	157.25(3) ^f stable		(after ... Gadolin) 1880
Gallium	Ga	31	69.723(1) stable		(Latin for both the discoverer's name and his nation, France) 1875
Germanium	Ge	32	72.64(1) stable		(from Germania, as opposed to gal- lium) 1886
Gold	Au	79	196.966 55(2) stable		heavy noble metal (Latin aurum) an- tiquity, electronics, jewels
Hafnium	Hf	72	178.49(2) ^c stable		(Latin for Copenhagen) 1923
Hassium ^b	Hs	108	(277) 16.5 min ^g	n.a.	(Latin form of German state Hessen) 1984
Helium	He	2	4.002 602(2) ^f stable		noble gas (Greek 'helios' sun) where it was discovered 1895
Holmium	Ho	67	164.930 32(2) stable		(Stockholm, Swedish capital) 1878
Hydrogen	H	1	1.007 94(7) ^f stable		gas (Greek for water-former) 1766

Name	sym- bol	at. num.	average mass ^a in u (with error) and longest lifetime	atomic ^e radius in pm	main properties (naming) use, and discovery date
Indium	In	49	114.818(3) stable		(Greek 'indikón' indigo) 1863
Iodine	I	53	126.904 47(3) stable		(Greek 'iodes' violet) 1811
Iridium	Ir	77	192.217(3) stable		(Greek 'iris' rainbow) 1804
Iron	Fe	26	55.845(2) stable	126	(Latin ferrum) antiquity
Krypton	Kr	36	83.80(1) ^f stable		(Greek 'kryptos' hidden) 1898
Lanthanum	La	57	138.9055(2) ^{c,f} stable		(Greek 'lanthanein' to be hidden) 1839
Lawrencium ^b	Lr	103	(262.110 97(1)) 3.6(3) h	n.a.	(after Ernest Lawrence) 1961
Lead	Pb	82	207.2(1) ^{c,f} stable		(Latin plumbum) antiquity
Lithium	Li	3	6.941(2) ^f stable		(Greek 'lithos' stone) 1817
Lutetium	Lu	71	174.967(1) ^f stable		(Latin 'Lutetia', old name of Paris) 1907
Magnesium	Mg	12	24.3050(6) stable		(from Magnesia, a Greek district in Thessalia) 1755
Manganese	Mn	25	54.938 049(9) stable		(Italian 'Manganese', a mineral) 1774
Meitnerium ^b	Mt	109	(268.1388(1)) 0.070 s ^g	n.a.	(after Lise Meitner) 1982
Mendelevium ^b	Md	101	(258.0984(1)) 51.5(3) d	n.a.	(after Dimitri Ivanovitch Mendeleiev) 1955
Mercury	Hg	80	200.59(2) stable		liquid metal (Greek 'hydrargyrum' liq- uid silver) antiquity
Molybdenum	Mo	42	95.94(1) ^f stable		(Greek 'molybdos' lead) 1788
Neodymium	Nd	60	144.24(3) ^{c,f} stable		(Greek 'neos' and 'didymos' new twin) 1885
Neon	Ne	10	20.1797(6) ^f stable		noble gas (Greek 'neos' new) 1898
Neptunium ^b	Np	93	(237.0482(1)) 2.14(1) Ma	n.a.	(planet Neptune, after Uranus) 1940
Nickel	Ni	28	58.6934(2) stable		(German 'Nickel' goblin) 1751
Niobium	Nb	41	92.906 38(2) stable		(Greek 'Niobe', mythical daughter of Tantalos) 1801
Nitrogen	N	7	14.0067(2) ^f stable		(Greek for nitre former) 1772
Nobelium ^b	No	102	(259.1010(1)) 58(5) min	n.a.	(after Alfred Nobel) 1958

Name	sym- bol	at. num.	average mass ^a in u (with error) and longest lifetime	atomic ^e radius in pm	main properties (naming) use, and discovery date
Osmium	Os	76	190.23(3) ^f stable		(from Greek 'osme' odour) 1804
Oxygen	O	8	15.9994(3) ^f stable		(formed from Greek to mean 'acid former') 1774
Palladium	Pd	46	106.42(1) ^f stable		(from asteroid 'Pallas' after the Greek goddess) 1802
Phosphorus	P	15	30.973 761(2) stable		(Greek 'phosphoros' light bearer) 1669
Platinum	Pt	78	195.078(2) stable		(Spanish 'platina' little silver) 1735
Plutonium	Pu	94	(244.0642(1)) 80.0(9) Ma	n.a.	(after the planet) 1940
Polonium	Po	84	(208.9824(1)) 102(5) a		(from Poland) 1898
Potassium	K	19	39.0983(1) stable		(Latin 'kalium' from Arabic 'quilyi', a plant used to produce potash, German 'Pottasche') 1807
Praseodymium	Pr	59	140.907 65(2) stable		(Greek 'praesos didymos' green twin) 1885
Promethium ^b	Pm	61	(144.9127(1)) 17.7(4) a		(from the Greek mythical figure of Prometheus) 1945
Protactinium	Pa	91	(231.035 88(2)) 32.5(1) ka	n.a.	radioactive (Greek 'protos' first, as it transforms into Actinium) 1917, found in nature
Radium	Ra	88	(226.0254(1)) 1599(4) a	n.a.	(Latin 'radius' ray) 1898
Radon	Rn	86	(222.0176(1)) 3.823(4) d	134	radioactive noble gas
Rhenium	Re	75	186.207(1) ^c stable		(Latin 'rhenus' for Rhine river) 1925
Rhodium	Rh	45	102.905 50(2) stable		(Greek 'rhodon' rose) 1803
Rubidium	Rb	37	85.4678(3) ^f stable		(Latin 'rubidus' red) 1861
Ruthenium	Ru	44	101.107(2) ^f stable		(Latin 'Rhuthenia' for Russia) 1844
Rutherfordium ^b	Rf	104	(261.1088(1)) 1.3 min ^g	n.a.	(after Ernest Rutherford) 1964
Samarium	Sm	62	150.36(3) ^{c,f} stable		(from the mineral Samarskite, after ...Samarski) 1879
Scandium	Sc	21	44.955 910(8) stable		(from Latin 'Scansia' Sweden) 1879
Seaborgium ^b	Sg	106	266.1219(1) 21 s ^g	n.a.	(after Glenn Seaborg) 1974
Selenium	Se	34	78.96(3) ^f stable		(Greek 'selene' moon) 1818

Name	sym- bol	at. num.	average mass ^a in u (with error) and longest lifetime	atomic ^e radius in pm	main properties (naming) use, and discovery date
Silicon	Si	14	28.0855(3) ^f stable		(Latin 'silex' pebble) 1823
Silver	Ag	47	107.8682(2) ^f stable		metal, (Latin argentum, Greek 'argyros') antiquity, used in photography
Sodium	Na	11	22.989 770(2) stable		(Egyptian, Arabic 'natrium' and Arabic 'souwad' soda) component of many salts
Strontium	Sr	38	87.62(1) ^f stable		(Strontian, Scottish town) 1790
Sulphur	S	16	32.065(5) ^f stable		(Latin) antiquity
Tantalum	Ta	73	180.9479(1) stable		(Greek Tantalos, a mythical figure) 1802
Technetium ^b	Tc	43	(97.9072(1)) 6.6(10) Ma		(Greek 'technetos' artificial) 1939
Tellurium	Te	52	127.60(3) ^f stable		(Latin 'tellus' earth) 1783
Terbium	Tb	65	158.925 34(2) stable		('Ytterby' Swedish town) 1843
Thallium	Tl	81	204.3833(2) stable		(Greek 'thallos' branch) 1861
Thorium	Th	90	232.0381(1) ^{d,f} 14.0(1) Ga		radioactive (nordic god Thor, as in thursday) 1828, found in nature
Thulium	Tm	69	168.934 21(2) stable		(Thule, mythical name for Scandinavia) 1879
Tin	Sn	50	118.710(7) ^f stable		(Latin stannum)
Titanium	Ti	22	47.867(1) stable		(Greek Titanos) 1791
Tungsten	W	74	183.84(1) stable		highest melting, heavy metal (German Wolfram, Swedish 'tung sten' heavy stone) 1783, light bulbs
Ununnilium ^b	Uun	110	(281) 1.6 min ^g	n.a.	1994, no use
Ununonium ^b	Uuu	111	(272.1535(1)) 1.5 ms ^g	n.a.	1994 no use
Ununbium ^b	Uub	112	(285) 15.4 min ^g	n.a.	1996, no use
Ununtrium	Uut	113		n.a.	not yet observed
Ununquadium ^b	Uuq	114	(289) 30.4 s ^g	n.a.	1999, no use
Ununpentium	Uup	115		n.a.	not yet observed
Ununhexium ^b	Uuh	116	(289) 0.6 ms ^g	n.a.	1999, no use
Ununseptium	Uus	117		n.a.	not yet observed
Ununoctium	Uuo	118		n.a.	not yet observed, but false claim in 1999
Uranium	U	92	238.028 91(3) ^{d,f} 4.468(3) · 10 ⁹ a	n.a.	radioactive (Planet Uranos, the Greek sky god) 1789, found in nature, used for nuclear energy

Name	sym- bol	at. num.	average mass ^a in u (with error) and longest lifetime	atomic ^e radius in pm	main properties (naming) use, and discovery date
Vanadium	V	23	50.9415(1) stable		('Vanadis' scandinavian goddess of beauty) 1830, used in steel
Xenon	Xe	54	131.293(6) ^f stable		noble gas (Greek 'xenos' foreign) 1898, used in lamps and lasers
Ytterbium	Yb	70	173.04(3) ^f stable		malleable heavy metal ('Ytterby' Swedish town) 1878, used in superconductors
Yttrium	Y	39	88.905 85(2) stable		malleable light metal ('Ytterby' Swedish town) 1794
Zinc	Zn	30	65.409(4) stable	153	heavy metal (German 'Zinke' protuberance) antiquity, iron rust protection
Zirconium	Zr	40	91.224(2) ^f stable	216	heavy metal (from the mineral zircon, after Arab 'zargum' golden colour) 1789, chemical and surgical instruments

a. The atomic mass unit is defined as $1 \text{ u} = \frac{1}{12} m(^{12}\text{C}) = 1.660\,5402(10) \text{ yg}$. For elements found on earth, the *average* atomic mass for the natural occurring isotope mixture is given, with the error in the last digit in brackets. For elements not found on earth, the mass of the *longest living* isotope is given; as it is not an average, it is written in brackets, as usual in this domain. Ref. 8

b. The element is not found on earth due to its short lifetime.

c. The element contains at least one radioactive isotope.

d. The element has no stable isotopes.

e. The *atomic radius* is not precisely defined, as atoms are clouds and as such have no boundary in principle. The atomic radius is not even useful for the estimation of molecular sizes; chemists have defined the so-called *covalent radius* to allow a rough estimate. The atomic radius is the radius determining atomic distances in solids of the given element. The covalent radius is often up to 0.1 nm smaller for elements on the (lower) left of the periodic table; on the (whole) right side it is essentially equal to the atomic radius. In between, the difference between the two decreases towards the right. Are you able to explain why? Challenge 765

Ionic radii differ considerably from atomic ones; a table can be found in ...

f. The isotopic composition and thus the average atomic mass of the element varies depending on the mining place or on subsequent human treatment, and can lie outside the values given. For example, the atomic mass of commercial lithium ranges between 6.939 and 6.996 u. The masses of isotopes are known in atomic mass units with nine or more significant digits, and usually with one or two digits less in kilogram. The errors in the atomic mass is thus mainly to the variations in isotope composition. For a precise isotope mass list, see the <http://csnwww.in2p3.fr> web site.

g. The lifetime errors are asymmetric or not well known.



References

- 1 This is deduced from the $g - 2$ measurements, as explained in his Nobel-prize talk by HANS DEHMELT, *Experiments with an isolated subatomic particle at rest*, Reviews of Modern Physics

- 62**, pp. 525–530, 1990, and in HANS DEHMELT, *Is the electron a composite particle?*, Hyperfine Interactions **81**, pp. 1–3, 1993. Cited on page **829**.
- 2** G. GABRIELSE, H. DEHMELT & W. KELLS, *Observation of a relativistic, bistable hysteresis in the cyclotron motion of a single electron*, Physical Review Letters **54**, pp. 537–540, 1985. Cited on page **829**.
- 3** The proton charge radius was determined by measuring the frequency of light emitted by hydrogen atoms to high precision by TH. UDEM, A. HUBER, B. GROSS, J. REICHERT, M. PREVEDELLI, M. WEITZ & T.W. HAUSCH, *Phase-coherent measurement of the hydrogen 1S-2S transition frequency with an optical frequency interval divider chain*, Physical Review Letters **79**, pp. 2646–2649, 1997. Cited on page **830**.
- 4** For a full list of isotopes, see R.B. FIRESTONE, *Table of Isotopes, Eighth Edition, 1999 Update*, with CDROM, John Wiley & Sons, 1999. For a list of isotopes on the web, the standard is the korean web site by J. CHANG, <http://hpngp01.kaeri.re.kr/CoN/index.html>, mirrored at <http://www.nes.ruhr-uni-bochum.de/CoN>. Cited on page **831**, **834**.
- 5** About the long life of tantalum 180, see D. BELIC & al., *Photoactivation of $^{180}\text{Ta}^m$ and its implications for the nucleosynthesis of nature's rarest naturally occurring isotope*, Physical Review Letters **83**, pp. 5242–5245, 20 december 1999. Cited on page **831**.
- 6** STEPHEN J. GOULD, 1980, *The Panda's thumb*, W.W. Norton & Co., New York. This is one of several interesting and informative books on evolutionary biology by the best writer in the field. Cited on page **831**.
- 7** For a good review, see the article by P.T. GREENLAND, *Antimatter*, Contemporary Physics **38**, pp. 181–203, 1997. Cited on page **833**.
- 8** The atomic masses, as given by IUPAC, can be found in Pure and Applied Chemistry **73**, pp. 667–683, 2001, or on the www.iupac.org web site. For an isotope mass list, see the <http://csnwww.in2p3.fr> web site. Cited on page **834**, **840**.
- 9** Almost everything known about each element and its chemistry can be found in the encyclopedic GMELIN, *Handbuch der anorganischen Chemie*, published from 1817 onwards. It presently has over 500 volumes, now all published in English under the title *Handbook of Inorganic and Organometallic Chemistry*, and contains at least one volume dedicated to each chemical element. Cited on page **834**.



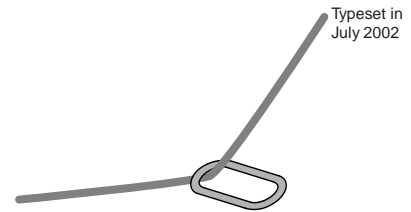

A mathematician is a machine that transforms coffee into theorems.
Paul Erdős (1913, Budapest–1996)

Mathematical concepts can all be constructed from ‘sets’ and ‘relations.’ The most important ones were presented in the the first intermezzo. In the following a few more advanced concepts are presented as simply and vividly as possible, * for all those who want to smell the passion of mathematics.

Ref. 1

In particular, we will expand the range of *algebraic* and the range of *topological* structures. Mathematicians are not only concerned with the exploration of concepts, but always also with their *classification*. Whenever a new mathematical concept is introduced, mathematicians try to classify all the possible cases and types. Most spectacularly this has been achieved for the different types of numbers, of simple groups, and for many types of spaces and manifolds.

More numbers

A person that can solve $x^2 - 92y^2 = 1$ in less than a year is a mathematician.
Brahmagupta, (598, Sindh–668) (implied: solve in *integers*)

Challenge 782

The concept of ‘number’ is not limited to what was presented in the first intermezzo. ** The simplest generalisation is achieved by extending them to manifolds of more than one dimension.

* The opposite approach is taken by the delightful text by CARL E. LINDERHOLM, *Mathematics made difficult*, Wolfe Publishing, 1971.

** An excellent introduction into number systems in mathematics is the book H.-D. EBBINGHAUS & al., *Zahlen*, 3. Auflage, Springer Verlag 1993. It is also available in English, under the title *Numbers*, Springer Verlag, 1990.

Complex numbers

Complex numbers are defined by $z = a + ib$. The generators of the complex numbers, 1 and i , obey the well known algebra

$$\begin{array}{c|cc} \cdot & 1 & i \\ \hline 1 & 1 & i \\ i & i & -1 \end{array} \tag{612}$$

often written as $i = +\sqrt{-1}$.

The *complex conjugate* z^* , also written \bar{z} , of a complex number $z = a + ib$ is defined as $z^* = a - ib$. The *absolute value* $|z|$ of a complex number is defined as $|z| = \sqrt{zz^*} = \sqrt{z^*z} = \sqrt{a^2 + b^2}$. It defines a *norm* on the vector space of the complex numbers. From $|wz| = |w| |z|$ follows the *two-squares theorem*

$$(a_1^2 + a_2^2)(b_1^2 + b_2^2) = (a_1b_1 - a_2b_2)^2 + (a_1b_2 + a_2b_1)^2 \tag{613}$$

valid for all real numbers a_i, b_i . It was already known, in its version for integers, to Diophantos of Alexandria.

This means that complex numbers can also be written as a couple (a, A) , with their addition defined as $(a, A) + (b, B) = (a + b, A + B)$ and their multiplication defined as $(a, A) \cdot (b, B) = (ab - AB, aB + bA)$. The two component writing allows to identify complex numbers with the points on a plane. Therefore, translating the definition of multiplication into geometrical language allows to rapidly prove geometrical theorems, such as the one of Figure 235.

Challenge 799

Complex numbers can also be represented as 2×2 matrices of the form

$$\begin{pmatrix} a & b \\ -b & a \end{pmatrix} \text{ with } a, b \in \mathbf{R} \tag{614}$$

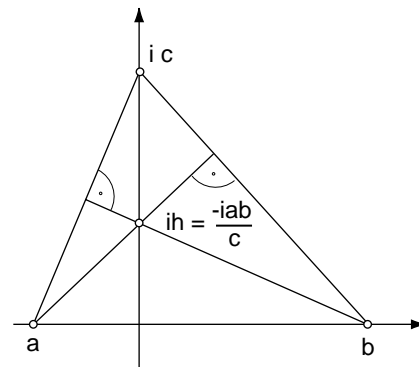

Figure 235 A property of triangles easily provable with complex numbers

Usual matrix addition and multiplication then give the same result as complex addition and multiplication. In this way, complex numbers can be represented by a special type of real matrices. What is $|z|$ in matrix language?

Challenge 816

The set \mathbf{C} of complex numbers with the mentioned multiplication forms a commutative two-dimensional field. In the field of complex numbers, quadratic equations $az^2 + bz + c = 0$ for an unknown z always have two solutions.

Challenge 833

Complex numbers can be used to describe the position of the points of a plane. Rotations around the origin can be described by multiplications by a complex number of unit length. Since complex numbers describe the two-dimensional plane, any two-dimensional quantity can be described with them. That is why electrical engineers use complex numbers to describe quantities with phases, such as alternating currents or electrical fields in space.

By the way, there are as many complex numbers as there are real numbers. Are you able to show this?

Challenge 850

Love is complex: it has real and imaginary parts.

Quaternions

The position of the points on a line can be described by real numbers. Complex numbers can be used to describe the position of the points of a plane. If one tries to generalize the idea of a number to higher dimensional spaces, it turns out that no number system can be defined for *three*-dimensional space. However a new number system, the *quaternions*, can be constructed from the points of *four*-dimensional space, but only if the requirement of commutativity of multiplication is dropped. In fact, no number system can be defined for dimensions other than 1, 2 and 4. The quaternions were discovered by several mathematicians in the 19th century, among them Hamilton,* who studied them for a long part of his life. In fact, Maxwell’s electrodynamics was formulated with quaternions before it was with three-dimensional vectors.

Ref. 2

The quaternions **H** form a 4-dimensional algebra over the reals with the basis $1, i, j, k$ satisfying

$$\begin{array}{c|cccc}
 \cdot & 1 & i & j & k \\
 \hline
 1 & 1 & i & j & k \\
 i & i & -1 & k & -j \\
 j & j & -k & -1 & i \\
 k & k & j & -i & -1
 \end{array} \tag{615}$$

which is also often written $i^2 = j^2 = k^2 = -1, ij = -ji = k, jk = -kj = i, ki = -ik = j$. The quaternions $1, i, j, k$ are also called *basic units* or *generators*. The missing symmetry along the diagonal of the table shows the lack of commutativity of quaternionic multiplication. With the quaternions, the idea of a non-commutative product appeared for the first time in mathematics. Despite this restriction, the multiplication of quaternions remains associative. As a consequence, polynomial equations in quaternions have many more solutions than in complex numbers; just find all solutions of the equation $X^2 + 1 = 0$ to find out.

Challenge 867

Every quaternion X can be written in the form

$$X = x_0 + x_1i + x_2j + x_3k = x_0 + \mathbf{v} = (x_0, x_1, x_2, x_3) = (x_0, \mathbf{v}) \quad , \tag{616}$$

where x_0 is called the *scalar* part and \mathbf{v} the *vector* part. The multiplication is thus defined as $(x, \mathbf{v})(y, \mathbf{w}) = (xy - \mathbf{v} \cdot \mathbf{w}, x\mathbf{w} + y\mathbf{v} + \mathbf{v} \times \mathbf{w})$. The multiplication of two general quaternions can be written as

$$\begin{aligned}
 (a_1, b_1, c_1, d_1)(a_2, b_2, c_2, d_2) = & (a_1a_2 - b_1b_2 - c_1c_2 - d_1d_2, a_1b_2 + b_1a_2 + c_1d_2 - d_1c_2, \\
 & a_1c_2 - b_1d_2 + c_1a_2 + d_1b_2, a_1d_2 + b_1c_2 - c_1b_2 + d_1a_2) \tag{617}
 \end{aligned}$$

* William Rowan Hamilton (1805, Dublin–1865, Dunsink), Irish child prodigy, mathematician, named the quaternions after an expression from the vulgate (act. apost. 12, 4).

The *conjugate quaternion* \bar{X} is defined as $\bar{X} = x_0 - \mathbf{v}$, so that $\bar{X}\bar{Y} = \overline{YX}$. The *norm* $|X|$ of a quaternion X is defined as $|X|^2 = X\bar{X} = \bar{X}X = x_0^2 + x_1^2 + x_2^2 + x_3^2 = x_0^2 + \mathbf{v}^2$. The norm is multiplicative, i.e. $|XY| = |X| |Y|$.

The relation $|XY| = |X| |Y|$ implies the *four-squares theorem*

$$\begin{aligned} & (a_1^2 + a_2^2 + a_3^2 + a_4^2)(b_1^2 + b_2^2 + b_3^2 + b_4^2) \\ &= (a_1b_1 - a_2b_2 - a_3b_3 - a_4b_4)^2 + (a_1b_2 + a_2b_1 + a_3b_4 - a_4b_3)^2 \\ & \quad + (a_1b_3 + a_3b_1 + a_4b_2 - a_2b_4)^2 + (a_1b_4 + a_4b_1 + a_2b_3 - a_3b_2)^2 \end{aligned} \quad (618)$$

valid for all real numbers a_i and b_i , and thus also for any set of eight integers. It was discovered in 1748 by Leonhard Euler (1707–1783) when trying to prove that each integer is the sum of four squares. (That proof was found only in 1770, by Joseph Lagrange.)

Hamilton thought that a quaternion with zero scalar part, which he simply called a *vector* – a term which he invented –, could be identified with an ordinary 3-dimensional translation vector; but this is wrong. Therefore, such a quaternion is now called a *pure*, or a *homogeneous*, or again, an *imaginary* quaternion. The product of two pure quaternions $V = (0, \mathbf{v})$ and $W = (0, \mathbf{w})$ is given by $VW = (-\mathbf{v} \cdot \mathbf{w}, \mathbf{v} \times \mathbf{w})$, where \cdot denotes the scalar product and \times denotes the vector product. Note that any general quaternion can be written as the ratio of two pure quaternions.

In reality, a pure quaternion $(0, \mathbf{v})$ does not behave under coordinate transformations like a (modern) vector; in fact, a pure quaternion represents a rotation by the angle π or 180°C around the axis defined by the direction $\mathbf{v} = (v_x, v_y, v_z)$.

Challenge 884

It turns out that in three-dimensional space, a *general* rotation about the origin can be described by a *unit* quaternion, also called a *normed* quaternion, for which $|Q| = 1$. Such a quaternion can be written as $(\cos\theta/2, \mathbf{n}\sin\theta/2)$, where $\mathbf{n} = (n_x, n_y, n_z)$ is the normed vector describing the direction of the rotation axis, and θ is the rotation angle. Such a unit quaternion $Q = (\cos\theta/2, \mathbf{n}\sin\theta/2)$ rotates a pure quaternion $V = (0, \mathbf{v})$ into another pure quaternion $W = (0, \mathbf{w})$ given by

$$W = QVQ^* \quad (619) \quad \text{Figure 236 Combinations of rotations}$$

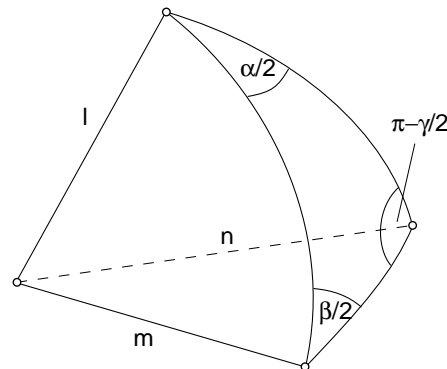

In this case, when using pure quaternions such as V or W to describe positions, unit quaternions can be used to describe rotations and to calculate coordinate changes. The concatenation of two rotations is then given as the product of the corresponding unit quaternions. Indeed, a rotation by an angle α about the axis \mathbf{l} followed by a rotation by an angle β about the axis \mathbf{m} gives a rotation by an angle γ about axis \mathbf{n} , with the values determined by

$$(\cos\gamma/2, \sin\gamma/2\mathbf{n}) = (\cos\alpha/2, \sin\alpha/2\mathbf{l})(\cos\beta/2, \sin\beta/2\mathbf{m}) \quad (620)$$

shown graphically in Figure 236.

Quaternions can teach something about the motion of hand and arm. Keeping the left arm straight, defining its three possible 90 degree motions as i , j , and k , and taking concatenation as multiplication, the motion of our arms follows the same ‘laws’ as those of pure unit quaternions. Can you find out what -1 is?

Challenge 901

The reason for this behaviour is the non-commutativity of rotations. This noncommutativity can be specified more precisely using mathematical language. The rotations in 3 dimensions around a point form the Special Orthogonal group in 3 dimensions, in short $SO(3)$. But the motions of a hand attached to a shoulder via an arm form another group, isomorphic to the Lie group $SU(2)$. The difference is due to the appearance of half angles in the parametrization of rotations; indeed, the above parametrizations imply that a rotation by 2π corresponds to a multiplication by -1 ! Only in the twentieth century it was realized that physical observables behaving in this way do exist: *spinors*. More on spinors can be found in the section on permutation symmetry, where belts are used as well as arms. In short, the group $SU(2)$ of the quaternions is the *double cover* of the rotation group $SO(3)$.

See page 529
Ref. 3

The easy description of rotations and positions with quaternions is used in robotics, in astronomy, and in flight simulators, due to the especially simple coding of coordinate transformations it provides. Inside three-dimensional graphic visualisation software, quaternions are often used to calculate the path taken by repeatedly reflected light rays.

The algebra of the quaternions is the unique associative noncommutative finite-dimensional normed algebra with an identity over the field of real numbers. Quaternions form a noncommutative field, i.e. a skew field, in which the inverse of a quaternion X is $\bar{X}/N(X)$. This allows to define a division of quaternions. Therefore quaternions are said to form a *division algebra*. In fact the quaternions \mathbf{H} , the complex numbers \mathbf{C} and the reals \mathbf{R} form the only three examples of finite dimensional associative division algebras. In other words, the skew-field of quaternions is the unique finite-dimensional real associative non-commutative algebra without divisors of zero. The *centre* of the quaternions, i.e. the set of those quaternions commuting with all quaternions, are the reals.

Like the complex numbers, quaternions can be represented as matrices of the form

$$\begin{pmatrix} A & B \\ -B^* & A^* \end{pmatrix} \text{ with } A, B \in \mathbf{C}, \quad \text{or as} \quad \begin{pmatrix} a & b & c & d \\ -b & a & -d & c \\ -c & d & a & -b \\ -d & -c & b & a \end{pmatrix} \text{ with } a, b, c, d \in \mathbf{R} \quad , \quad (621)$$

where $A = a + ib, B = c + id$ and the quaternion X is $X = A + Bj = a + ib + jc + kd$; usual matrix addition and multiplication then give the same result as quaternionic addition and multiplication.

The generators of the quaternions can be realised for example as

$$1 : \sigma_0 \quad , \quad i : -i\sigma_1 \quad , \quad j : -i\sigma_2 \quad , \quad k : -i\sigma_3 \quad (622)$$

where the σ_n are the Pauli spin matrices.*

* The *Pauli spin matrices* are the complex, hermitean matrices

$$\sigma_0 = \mathbf{1} = \begin{pmatrix} 1 & 0 \\ 0 & 1 \end{pmatrix} \quad , \quad \sigma_1 = \begin{pmatrix} 0 & 1 \\ 1 & 0 \end{pmatrix} \quad , \quad \sigma_2 = \begin{pmatrix} 0 & -i \\ i & 0 \end{pmatrix} \quad , \quad \sigma_3 = \begin{pmatrix} 1 & 0 \\ 0 & -1 \end{pmatrix} \quad (623)$$

This is a section of the freely downloadable e-textbook

Motion Mountain

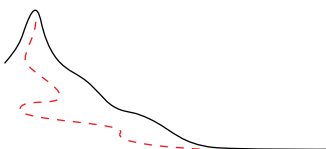

Hiking beyond space and time along the concepts of modern physics

available at
www.motionmountain.org

Copyright © 1997, 1998, 1999, 2000, 2001, 2002 by Christoph Schiller

To the kind reader

In exchange for getting this section for free, I ask you for a short email on some of the following:

- Which page was boring?
- Did you find any mistakes?
- What else were you expecting?
- What was hard to understand?

Of course, any other suggestion is welcome. This section is part of a physics text written over many years. The text lives and grows through the feedback from its readers, who help to improve and to complete it. For a particularly useful contribution (send it in english, italian, dutch, german, spanish, portuguese, or french) you will be mentioned in the foreword of the text, or receive a small reward, or both.

Enjoy!

Christoph Schiller
cs@motionmountain.org

Challenge 918

Real 4×4 representations are not unique, as

$$\begin{pmatrix} a & b & -d & -c \\ -b & a & -c & d \\ d & c & a & b \\ c & -d & -b & a \end{pmatrix} \quad (624)$$

shows; however, no representation by 3×3 matrices is possible.

Challenge 935

These matrices contain real and complex elements, which pose no special problems. In contrast, when matrices with quaternionic elements are constructed, care has to be taken, because simple relations, such as $\text{tr}AB = \text{tr}BA$ are *not* fulfilled in general, since quaternionic multiplication is not commutative.

What do we learn from quaternions for the description of nature? First of all, binary rotations are similar to positions, and thus to translations. Are rotations the basic operations? Is it possible that translations are only shadows of rotations? The ways that translations are connected to rotations are investigated in the second and third part of the mountain ascent.

As a remark, when Maxwell wrote down his equations of electrodynamics, he used quaternion notation. The now usual 3-vector notation was introduced later by other scientists, notably by Hertz and Heaviside. Maxwell's original equations of electrodynamics, in modern quaternion notation, read:

See page 353

Challenge 952

$$dF = -\frac{Q}{\epsilon_0} \quad (625)$$

where the quantities are defined as following:

$$\begin{aligned} F &= E + \sqrt{-1}cB \\ E &= iE_x + jE_y + kE_z \\ B &= iB_x + jB_y + kB_z \\ d &= \delta + \sqrt{-1}\partial_t/c \\ \delta &= i\partial_x + j\partial_y + k\partial_z \\ Q &= \rho + \sqrt{-1}J/c \end{aligned} \quad (626)$$

and where $\sqrt{-1}$ is the complex root of -1 .

Octonions

In the same way that the quaternions are constructed from complex numbers, octonions can be constructed from quaternions, as done by Arthur Cayley (1821–1895). *Octonions* or *octaves* are the elements of an 8-dimensional algebra over the reals with the generators $1, i_n$

whose eigenvalues are ± 1 ; they satisfy the relations $[\sigma_i, \sigma_k]_+ = 2\delta_{ik}$ and $[\sigma_i, \sigma_k] = 2i\epsilon_{ikl}\sigma_l$. The linear combinations $\sigma_{\pm} = \frac{1}{2}(\sigma_1 \pm \sigma_2)$ are also frequently used. By the way, another possible representation of the quaternions is $i : i\sigma_3, j : i\sigma_2, k : i\sigma_1$.

with $n = 1 \dots 7$ satisfying

	1	i_1	i_2	i_3	i_4	i_5	i_6	i_7
1	1	i_1	i_2	i_3	i_4	i_5	i_6	i_7
i_1	i_1	-1	i_3	$-i_2$	i_5	$-i_4$	i_7	$-i_6$
i_2	i_2	$-i_3$	-1	i_1	$-i_6$	i_7	i_4	$-i_5$
i_3	i_3	i_2	$-i_1$	-1	i_7	i_6	$-i_5$	$-i_4$
i_4	i_4	$-i_5$	i_6	$-i_7$	-1	i_1	$-i_2$	i_3
i_5	i_5	i_4	$-i_7$	$-i_6$	$-i_1$	-1	i_3	i_2
i_6	i_6	$-i_7$	$-i_4$	i_5	i_2	$-i_3$	-1	i_1
i_7	i_7	i_6	i_5	i_4	$-i_3$	$-i_2$	$-i_1$	-1

(627)

Nineteen other, equivalent multiplication tables are also possible. This algebra is called the *Cayley algebra*; it has an identity and a unique division. The algebra is non-commutative and also non-associative. It is however, *alternative*, meaning that for all elements, one has $x(xy) = x^2y$ and $(xy)y = xy^2$, a property somewhat weaker than associativity. It is the only 8-dimensional real alternative algebra without zero divisors. For this last reason, the set \mathbf{O} of all octonions does not form a field nor a ring, and the old designation of ‘Cayley numbers’ has been abandoned. The octonions are the most general hypercomplex ‘numbers’ whose norm is multiplicative. Associativity is not satisfied, since $(i_n i_m) i_l = \pm i_n (i_m i_l)$, where the minus sign is valid for combination of indices which belong to those triads, such as 1-2-4, which are not quaternionic.

Octonions can be represented as matrices of the form

$$\begin{pmatrix} A & B \\ -\bar{B} & \bar{A} \end{pmatrix} \quad \text{where } A, B \in \mathbf{H} \quad , \quad \text{or as real } 8 \times 8 \text{ matrices.} \tag{628}$$

Matrix multiplication then gives the same result as octonionic multiplication.

The relation $|wz| = |w| |z|$ allows to deduce the impressive *eight-squares theorem*

$$\begin{aligned} & (a_1^2 + a_2^2 + a_3^2 + a_4^2 + a_5^2 + a_6^2 + a_7^2 + a_8^2)(b_1^2 + b_2^2 + b_3^2 + b_4^2 + b_5^2 + b_6^2 + b_7^2 + b_8^2) \\ &= (a_1 b_1 - a_2 b_2 - a_3 b_3 - a_4 b_4 - a_5 b_5 - a_6 b_6 - a_7 b_7 - a_8 b_8)^2 \\ &+ (a_1 b_2 + a_2 b_1 + a_3 b_4 - a_4 b_3 + a_5 b_6 - a_6 b_5 - a_7 b_8 + a_8 b_7)^2 \\ &+ (a_1 b_3 - a_2 b_4 + a_3 b_1 + a_4 b_2 + a_5 b_7 + a_6 b_8 - a_7 b_5 - a_8 b_6)^2 \\ &+ (a_1 b_4 + a_2 b_3 - a_3 b_2 + a_4 b_1 + a_5 b_8 - a_6 b_7 + a_7 b_6 - a_8 b_5)^2 \\ &+ (a_1 b_5 - a_2 b_6 - a_3 b_7 - a_4 b_8 + a_5 b_1 + a_6 b_2 + a_7 b_3 + a_8 b_4)^2 \\ &+ (a_1 b_6 + a_2 b_5 - a_3 b_8 + a_4 b_7 - a_5 b_2 + a_6 b_1 - a_7 b_4 + a_8 b_3)^2 \\ &+ (a_1 b_7 + a_2 b_8 + a_3 b_5 - a_4 b_6 - a_5 b_3 + a_6 b_4 + a_7 b_1 - a_8 b_2)^2 \\ &+ (a_1 b_8 - a_2 b_7 + a_3 b_6 + a_4 b_5 - a_5 b_4 - a_6 b_3 + a_7 b_2 + a_8 b_1)^2 \end{aligned} \tag{629}$$

valid for all real numbers a_i and b_i , and thus in particular also for all integers. It was discovered in 1818 by Carl Friedrich Degen (1766–1825), and then rediscovered in 1844 by John Graves and in 1845 by Cayley. There is no generalization to higher numbers of squares, a fact proven by Adolf Hurwitz (1859–1919) in 1898.

As a note, the octonions can be used to show that a vector product is not only possible in dimensions 3. A *vector product* or *cross product* is an operation satisfying

$$\begin{aligned} u \times v &= -v \times u && \text{anticommutativity} \\ (u \times v)w &= u(v \times w) && \text{exchange rule.} \end{aligned} \quad (630)$$

Using the definition

$$X \times Y = \frac{1}{2}(XY - YX) \quad , \quad (631)$$

the \times -products of imaginary quaternions, i.e. of quaternions of the sort $(0, \mathbf{u})$, are again imaginary, and the \mathbf{u} 's obey the usual vector product, thus fulfilling (630). Interestingly, using definition (631) for *octonions* is possible. In that case the product of imaginary octonions, i.e. octonions of the sort $(0, \mathbf{U})$, also yields only imaginary octonions, and the \mathbf{U} 's also follow expression (630). In fact, this is the only other nontrivial example possible. Thus a vector product exists only in 3 and in 7 dimensions.

Ref. 4
Challenge 969

Other types of numbers

The process of construction of a new system of hypercomplex 'numbers' or real algebras by 'doubling' a given one can be continued ad infinitum. However, octonions, *sedonions* and all the following doublings are neither rings nor fields, but only non-associative algebras with unity. Other finite-dimensional algebras with unit element over the field of the reals, once generally called hypercomplex 'numbers', can also be defined, such as 'dual numbers', 'double numbers', 'Clifford-Lifshitz numbers' etc. They play no special role in physics.

Mathematicians also have defined number fields which have 'one and a half' dimensions, such as algebraic number fields. There is also a generalisation of the concept of integers to the complex domain, the *gaussian integers*, defined as $n + im$. Gauss even defined what now are known as *gaussian primes*. (Can you find out how?) They are not used in the description of nature, but are important in number theory.

Ref. 5
Challenge 986

As a note, in the old days physicists used to call quantum mechanical operators 'q-numbers.' But this term has now fallen out of fashion.

Other extensions of the natural numbers are those which include numbers larger than the smallest type of infinity. The most important *transfinite numbers* are the *ordinals*, the *cardinals*, and the mentioned *surreals*. The ordinals are essentially the infinite integers (and the finite ones), whereas the surreals are the infinite (and finite) reals. The surreals were defined in the first intermezzo. They are to the ordinal numbers what the reals are to the integers: they fill up all the gaps in between. Interestingly, for the surreals, the summation of many divergent series in \mathbf{R} converge. Can you find one example?

Ref. 6
See page 436
Challenge 1003

The surreals also include infinitely small numbers. That is also the case for the numbers of *nonstandard analysis*, also called *hyperreals*. In both number systems, in contrast to the case of the real numbers, the numbers $0.999\overline{9}$ and 1 do not coincide, but are separated by infinitely many other numbers.

Ref. 4

Grassmann numbers

With the discovery of supersymmetry, another type of numbers became important, the *Grassmann numbers*.^{*} They are in fact a special type of hypercomplex ‘numbers’. In supersymmetric Lagrangians, fields depend on two types of coordinates: on the usual real space-time coordinates and additionally on Grassmann coordinates.

Grassmann numbers, also called *fermionic coordinates*, θ have the defining properties

$$\theta^2 = 0 \quad \text{and} \quad \theta_i \theta_j + \theta_j \theta_i = 0 \quad . \quad (632)$$

Challenge 1020 You may want to look for a representation of these numbers. More about their use can be found in the section on supersymmetry.

Vector spaces

Vector spaces, also called linear spaces, are mathematical generalisations of certain aspects of the intuitive three-dimensional space. Any set of elements that can be added together and also be multiplied by numbers is called a vector space, if the result is again in the set and the usual rules of calculation hold.

More precisely, a *vector space* over a number field K is a set of elements, called *vectors* in this case, for which a vector addition and a *scalar multiplication* is defined for all vectors a, b, c and for all numbers s and r from K with the properties

$$\begin{aligned} (a + b) + c = a + (b + c) &= a + b + c && \text{associativity of vector addition} \\ n + a = n &&& \text{existence of null vector} \\ (-a) + a = n &&& \text{existence of negative vector} \\ 1a = a &&& \text{regularity of scalar multiplication} \\ (s + r)(a + b) = sa + sb + ra + rb &&& \text{complete distributivity of scalar multiplication} \end{aligned} \quad (633)$$

If the field K , whose elements are called *scalars* in this context, is taken to be the real (complex, quaternionic) numbers, one speaks of a real (complex, quaternionic) vector space. Vector spaces are also called *linear vector spaces* or simply *linear spaces*.

The complex numbers, the set of all functions defined on the real line, the set of all polynomials, the set of matrices of given number of rows and columns all form vector spaces. In mathematics, a vector is thus a more general concept than in physics. Physical vectors are more specialized objects, namely elements of normed inner product spaces. To define them one first needs the concept of metric space.

A *metric space* is a vector space with a metric, i.e. a way to define distances between elements. A relation $d(a, b)$ between elements is called a metric if

$$\begin{aligned} d(a, b) &\geq 0 && \text{positivity of metric} \\ d(a, b) + d(b, c) &\geq d(a, c) && \text{triangle inequality} \\ d(a, a) &= 0 && \text{regularity of metric} \end{aligned} \quad (634)$$

Challenge 1037 For example, measuring the distance between cities in France, i.e. points on a surface, by the shortest distance of travel via Paris, except in the case if they both lie on a line already

^{*} Hermann Günther Grassmann (1809–1877) mathematician.

going through Paris, defines a metric between the points in France.

A *normed* vector space is, obviously, a linear space with norm, or ‘length’ of a vector. A norm is a positive (or vanishing) number $\|a\|$ defined for each vector a with the properties

$$\begin{aligned} \|ra\| &= |r| \|a\| && \text{linearity of norm} \\ \|a+b\| &\leq \|a\| + \|b\| && \text{triangle inequality} \\ \|a\| = 0 &\text{ only if } a = 0 && \text{regularity} \end{aligned} \quad (635)$$

Usually there are many ways to define a norm for a given space. Note that a norm can always be used to define a metric by setting Challenge 1054

$$d(a, b) = \|a - b\| \quad (636)$$

so that all normed spaces are also metric spaces. The most special linear spaces are *inner product spaces*. They are vector spaces with an *inner product*, also called *scalar product* (not to be confused with the scalar multiplication!). For an inner product in the *real* case the properties of

$$\begin{aligned} ab &= ba && \text{commutativity of scalar product} \\ (ra)(sb) &= rs(ab) && \text{bilinearity of scalar product} \\ (a+b)c &= ac + bc && \text{left distributivity of scalar product} \\ a(b+c) &= ab + ac && \text{right distributivity of scalar product} \\ aa &\geq 0 && \text{positivity of scalar product} \\ aa = 0 &\text{ only if } a = 0 && \text{regularity of scalar product} \end{aligned} \quad (637)$$

hold for all vectors a, b and all scalars r, s . A *real* inner product space (of finite dimension) is also called a *Euclidean* vector space. The set of all velocities, the set of all positions, or the set of all possible momenta form such spaces.

In the *complex* case this definition is extended to*

$$\begin{aligned} ab &= \overline{(ba)} = \bar{b}\bar{a} && \text{hermitean property} \\ (ra)(sb) &= \bar{r}s(ab) && \text{sesquilinearity of scalar product} \\ (a+b)c &= ac + bc && \text{left distributivity of scalar product} \\ a(b+c) &= ab + ac && \text{right distributivity of scalar product} \\ aa &\geq 0 && \text{positivity of scalar product} \\ aa = 0 &\text{ only if } a = 0 && \text{regularity of scalar product} \end{aligned} \quad (638)$$

hold for all vectors a, b and all scalars r, s . A *complex* inner product space (of finite dimension) is also called a *unitary* or *hermitean* vector space. If the inner product space is *complete*, it is called, especially in the infinite-dimensional complex case, a *Hilbert space*. The space of all possible states of a quantum system form a Hilbert space.

* The term *sesquilinear* is Latin for ‘one-and-a-half-linear’. Sometimes however, the half-linearity is assumed in the other argument.

All inner product spaces are also metric spaces and thus normed spaces, if the metric is defined, as usually done, by

$$d(a,b) = \sqrt{(a-b)(a-b)} \quad (639)$$

In inner product spaces, a *basis* can be defined, allowing to speak about the length and the direction of vectors, as we are used to in physics.

Algebras

The term *algebra* is used in mathematics with three different, but loosely related meanings. It denotes a part of mathematics, as in ‘I hated algebra at school’; it further denotes in general any formal rules that are obeyed by abstract objects, as e.g. in the expression ‘tensor algebra’. Finally it denotes a specific mathematical structure, which is the only meaning used here.

An *algebra* $A = \{x, y, \dots\}$ is a set of elements with an addition and a multiplication having the properties that for all elements

$$\begin{aligned} x + y &= y + x && \text{commutativity of addition} \\ x(y + z) &= xy + xz \quad , \quad (x + y)z = xz + yz && \text{distributivity of multiplication} \quad (640) \\ xx &\geq 0 && \text{positivity} \\ xx = 0 &\text{ only if } x = 0 && \text{regularity of multiplication} \end{aligned}$$

As is clear from this definition, algebras are rather general mathematical structures. In physics, those special algebras related to symmetries play the most important role.

An *associative algebra* is an algebra whose multiplication has the additional property of

$$x(yz) = (xy)z \quad \text{associativity} \quad (641)$$

Most physical algebras are associative.

A *linear algebra* is an algebra over a number field with the property that a multiplication by scalars c is defined such that

$$c(xy) = (cx)y = x(cy) \quad \text{linearity} \quad (642)$$

For example, the set of all linear transformations in an n-dimensional linear space, such as the translations on a plane, in space or in time, are linear algebras. So is the set of observables of a quantum mechanical system.* Note that all linear algebras are themselves vector

* Linear transformations are mathematical objects which transform a vector into another with the property that sums and multiples of vectors are transformed into sums and the multiples of the transformed vectors. Are you able to give the set of all possible linear transformations of points on a plane? And in space? And in Minkowski space?

Challenge 1071

You will discover that all linear transformations transform some special vectors, called *eigenvectors* – from the German word ‘eigen’ meaning self’ – into multiples of themselves. In other words, if a transformation T has the effect

$$Te = \lambda e \quad (643)$$

spaces; the difference being that also a (linear) and associative multiplication among the vectors is defined.

A *star algebra*, also written **-algebra*, is an algebra over the *complex* numbers for which there is a mapping $*$: $A \rightarrow A$, $x \mapsto x^*$, called an *involution*, with the properties

$$\begin{aligned}(x^*)^* &= x \\ (x+y)^* &= x^* + y^* \\ (cx)^* &= c^*x^* \quad \text{for all } c \in \mathbf{C} \\ (xy)^* &= y^*x^*\end{aligned}\tag{644}$$

valid for all elements x, y of the algebra A . The element x^* is called the *adjoint* of x . Star algebras are the main structure used in quantum mechanics, since quantum mechanical observables form a **-algebra*.

A *C*-algebra* is a Banach algebra over the complex numbers with an involution $*$ so that the norm $\|x\|$ of an element x can be defined as

$$\|x\|^2 = x^*x\tag{645}$$

and which it is a *complete* vector space, i.e. one in which Cauchy sequences converge. The name \mathbf{C} comes from ‘continuous functions’; they form such an algebra with a properly defined norm. Can you find it?

Challenge 1088

All *C*-algebras* contain a space of hermitean elements (which have a real spectrum), a set of normal elements, a multiplicative group of unitary elements and a set of positive elements (with nonnegative spectrum).

One important type of *mathematical algebra* deserves to be mentioned. A *division algebra* is an algebra for which $ax = b$ and $ya = b$ are uniquely solvable in x or y for all b and all $a \neq 0$. Division algebras are thus one way to generalize the concept of a number. One of the important results of modern mathematics states that division algebras can *only* have dimension 1, like the reals, or dimension 2, like the complex numbers, or dimension 4, like the quaternions, or dimension 8, like the octonions. There is thus no way to generalize the concept of ‘number’ to other or to higher dimensions.

Lie algebras

A Lie algebra is special type of algebra and of vector space. A vector space L over the field \mathbf{R} (or \mathbf{C}) with an additional binary operation $[\ , \]$ called *Lie multiplication* or the *commutator*, is called a real (or complex) Lie algebra if this operation fulfils the properties

$$\begin{aligned}[X, Y] &= -[Y, X] && \text{antisymmetry} \\ [aX + bY, Z] &= a[X, Z] + b[Y, Z] && \text{linearity} \\ [X, [Y, Z]] + [Y, [Z, X]] + [Z, [X, Y]] &= 0 && \text{Jacobi identity}\end{aligned}\tag{646}$$

the vector e is called an *eigenvector*, and λ its associated *eigenvalue*. The set of all eigenvalues of a transformation T is called the *spectrum* of T . Physicists did not care for these mathematical concepts until they discovered quantum theory. Quantum theory showed that observables are transformations in Hilbert space, because any measurement interacts with a system and thus transforms it. Quantum mechanical experiments also showed that a measurement result for an observable can only be one of the eigenvalues of the corresponding transformation. The state of the system after the measurement is given by the eigenvector of the measured eigenvalue. Therefore every expert on motion must know what an eigenvalue is.

See page ??

See page 549

for all elements $X, Y, Z \in L$ and for all $a, b \in \mathbf{R}$ (or \mathbf{C}). A Lie algebra is called *commutative* if $[X, Y] = 0$ for all elements X and Y . The *dimension* of the Lie algebra is the dimension of the vector space. A subspace N of a Lie algebra L is called an *ideal* if $[L, N] \subset N$; any ideal is also a *subalgebra*. A *maximal ideal* M which satisfies $[L, M] = 0$ is called the *centre* of L .

A Lie algebra is called a *linear* Lie algebra if its elements are linear transformations of another vector space V , simply said, if they are ‘matrices’. It turns out that every finite dimensional Lie algebra is isomorphic to a linear Lie algebra. Therefore, by picturing the elements of Lie algebras in terms of matrices all finite dimensional cases are covered.

The name ‘Lie algebra’ was chosen because the *generators*, i.e. the infinitesimal elements of every Lie group form a Lie algebra. Since all important symmetries in nature form Lie groups, Lie algebras appear very frequently in physics. In mathematics, Lie algebras arise frequently because from any associative finite dimensional algebra in which the symbol \cdot stands for its multiplication, a Lie algebra appears when defining the *commutator* by

$$[X, Y] = X \cdot Y - Y \cdot X \quad ; \quad (647)$$

this fact gave the commutator its name. Therefore a Lie algebra can also be seen as a special type of associative algebra.

Since Lie algebras are vector spaces, the elements T_i of a *basis* of the Lie algebra always obey the relation:

$$[T_i, T_j] = \sum_k c_{ij}^k T_k \quad (648)$$

where the numbers c_{ij}^k are called the structure constants of the Lie algebra. They depend on the chosen basis. Structure constants determine the Lie algebra completely. For example, the algebra of the Lie group $SU(2)$, with the three generators defined by $T_a = \sigma^a / 2i$, where the σ^a are the Pauli spin matrices, has the structure constants $C_{abc} = \epsilon_{abc}$.*

See page 846

* In the same ways as groups, Lie algebras can be represented by matrices, i.e. by linear operators. Representations of Lie algebras are important in physics because many continuous symmetry groups are Lie groups.

The *adjoint representation* of a Lie algebra with basis $a_1 \dots a_n$ is the set of matrices $\text{ad}(a)$ defined for each element a by

$$[a, a_j] = \sum_c \text{ad}(a)_{cj} a_c \quad . \quad (649)$$

It implies that $\text{ad}(a)_{jk} = c_{ij}^k$, where c_{ij}^k are the structure constants of the Lie algebra. For a real Lie algebra, all elements of $\text{ad}(a)$ are real for all $a \in L$.

Note that for any Lie algebra, a scalar product can be defined by setting

$$(X, Y) = \text{Tr}(\text{ad}X \text{ad}Y) \quad . \quad (650)$$

This scalar product is symmetric and bilinear. The corresponding bilinear form is also called the *Killing form*, after the German mathematician Wilhelm Killing (1847–1923), the discoverer of the exceptional Lie groups. The Killing form is invariant under the action of any automorphism of the algebra L . In a given basis, one has

$$(X, Y) = \text{Tr}((\text{ad}X)_k^i (\text{ad}Y)_i^j) = c_{lk}^i c_{si}^j y^s = g_{ls} x^l y^s \quad (651)$$

where $g_{ls} = c_{lk}^i c_{si}^k$ is called the *Cartan metric tensor* of the Lie algebra L .

Classification of Lie algebras

All Lie algebras can be divided in finite-dimensional and infinite dimensional ones. Every *finite-dimensional* Lie algebra turns out to be the (semidirect) sum of a semisimple and a solvable Lie algebra.

A Lie algebra is called *solvable* if, well, if it is not semisimple. Solvable Lie algebras have not been classified completely up to now. They are not important in physics.

A *semisimple* Lie algebra is a Lie algebra which has no non-zero solvable ideal. Other equivalent definitions are possible, depending on your taste:

- a semisimple Lie algebra does not contain non-zero abelian ideals,
- its Killing-form is non-singular, i.e. non-degenerate,
- it splits into the direct sum of non-abelian simple ideals (this decomposition is unique)
- every finite-dimensional linear representation is completely reducible
- the one-dimensional cohomology of g with values in an arbitrary finite-dimensional g -module is trivial.

All finite-dimensional semisimple Lie algebras have been completely classified. Every semisimple Lie algebra decomposes uniquely into a direct sum of *simple* Lie algebras. Simple Lie algebras can be complex or real.

The simple finite-dimensional *complex* Lie algebras all belong to four infinite classes and to five exceptional cases. The infinite classes are also called *classical* and are A_n for $n \geq 1$, corresponding to the Lie groups $SL(n)$ and their compact ‘cousins’ $SU(n)$, B_n for $n \geq 2$, corresponding to the Lie groups $SO(2n+1)$, C_n for $n \geq 3$, corresponding to the Lie groups $Sp(2n)$, and D_n for $n \geq 4$, corresponding to the Lie groups $SO(2n)$. These simple Lie algebras are defined as follows. A_n is the algebra of all skew-hermitean $n \times n$ matrices, B_n, C_n are the algebras of the symmetric $n \times n$ matrices, and D_n is the algebra of the traceless $n \times n$ matrices.

The exceptional Lie algebras are G_2, F_4, E_6, E_7, E_8 . In all cases, the index gives the number of roots. The dimension of the algebras is $A_n : n(n+2)$, B_n and $C_n : n(2n+1)$, $D_n : n(2n-1)$, $G_2 : 14$, $F_4 : 32$, $E_6 : 78$, $E_7 : 133$, $E_8 : 248$.

The simple and finite-dimensional *real* Lie algebras are more numerous; they follow from the list of complex Lie algebras. Moreover, for each complex Lie group, there is always one compact real one. Real Lie algebras are not so important in fundamental physics.

Ref. 7

Of the large number of *infinite dimensional* Lie algebras only few are important in physics, among them the *Poincaré algebra*, the *Cartan algebra*, the *Virasoro algebra*, and a few other Kac-Moody algebras.

For supersymmetry, i.e. for systems with anticommuting coordinates, the concept of Lie algebra has been extended, and so-called Lie-superalgebras have been defined.

The Virasoro algebra

The *Virasoro algebra* is the infinite algebra of operators L_n satisfying

$$[L_m, L_n] = (m-n)L_{m+n} + \frac{c}{12}(m^3 - m)\delta_{m,-n} \quad (652)$$

where the number c , which may be zero, is called the *central charge*, and the factor $1/12$ is introduced by historical convention. This rather specific algebra is important in physics

Challenge 1105

because it is the algebra of conformal symmetry in *two* dimensions, as explained on page 638.* Are you able to find a representation in terms of infinite square matrices? Mathematically speaking, the Virasoro algebra is a special case of a Kac-Moody algebra.

– CS – sections on topology, integration, and Lie groups to be added – CS –

Topology is group theory.
The Erlangen program



References

- 1 A general basis can be the *Encyclopedia of Mathematics*, in 10 volumes, Kluwer Academic Publishers, Dordrecht, 1988–1993. It explains carefully all concepts used in mathematics. Spending an hour with it looking up related keywords is an efficient way to get an introduction into any part of mathematics, especially into the vocabulary and the main connections. Cited on page 842.
- 2 S.L. ALTMAN, *Rotations, Quaternions and Double Groups*, Clarendon Press, 1986, and also S.L. ALTMAN, *Hamilton, Rodriguez, and the quaternion scandal*, *Mathematical Magazine* pp. 291–308, 1988. Cited on page 844.
- 3 See the fine book by LOUIS H. KAUFFMAN, *Knots and Physics*, World Scientific, second edition, 1994, which gives a clear and visual introduction to the mathematics of knots and its main applications to physics. Cited on page 846.
- 4 A good introduction to nonstandard numbers, quaternions, octonions, p-adic numbers, surreal numbers, and more is H.-D. EBBINGHAUS, H. HERMES, F. HIRZEBRUCH, M. KOECHER, K. MAINZER, J. NEUKIRCH, A. PRESTEL & R. REMMERT, *Zahlen*, Springer Verlag, 1993, also available in English as *Numbers*, Springer Verlag, 1990. Cited on page 849, 850.
- 5 Gaussian numbers are presented and explained in ... Cited on page 850.
- 6 About transfinite numbers, see the delightful paperback by RUDY RUCKER, *Infinity and the Mind – the Science and Philosophy of the Infinite*, Bantam, Toronto, 1983. Cited on page 850.
- 7 M. FLATO, P. SALLY & G. ZUCKERMAN, (editors) *Applications of Group Theory in Physics and Mathematical Physics*, Lectures in applied mathematics, volume 21, American Mathematical Society 1985. This interesting book has been written before the superstring revolution, so that the latter topic is missing in the otherwise excellent presentation. Cited on page 856.



See page 204 * Note that the conformal symmetry group in *four* dimensions has 15 parameters, and thus its Lie algebra is finite (fifteen) dimensional.

APPENDIX E INFORMATION SOURCES ON MOTION



I only know that I know nothing.
Socrates (470–399 BCE)

In the text, outstanding books introducing neighbouring domains are presented in footnotes. The reference list at the end of each chapter collects general material satisfying further curiosity about what is encountered in this mountain ascent. All citations can also be found by looking up the author's name in the index. To find additional information, either libraries or the internet can help.

In a library, review articles of recent research appear in journals such as *Reviews of Modern Physics*, *Reports on Progress in Physics*, *Contemporary Physics* and *Advances in Physics*. Pedagogical introductions are best found in the *American Journal of Physics*, the *European Journal of Physics* and in *Physik in unserer Zeit*.

Actual overviews on research trends can be found irregularly in magazines such as *Physics World*, *Physics Today* and *Physikalische Blätter*. For all sciences together, the best sources are the magazines *Nature*, *New Scientist*, *Naturwissenschaften*, *La Recherche* and the cheap but excellent *Science News*.

Research papers appear mainly in *Physics Letters B*, *Nuclear Physics B*, *Physical Review D*, *Physical Review Letters*, *Classical and Quantum Gravity*, *General Relativity and Gravitation*, *International Journal of Modern Physics* and in *Modern Physics Letters*. The newest results and speculative ideas are found in conference proceedings, such as the *Nuclear Physics B Supplements*. Articles on the topic can also appear in *Fortschritte der Physik*, *Zeitschrift für Physik C*, *La Rivista del Nuovo Cimento*, *Europhysics Letters*, *Communications in Mathematical Physics*, *Journal of Mathematical Physics*, *Foundations of Physics*, *International Journal of Theoretical Physics* and *Journal of Physics G*.

Papers on the description of motion without time and space which appear after this text can be found via the *Scientific Citation Index*. It is published in printed form or as compact disk and allows, given a paper, e.g. one from the references at the end of each chapter, to search for all subsequent publications which cite it. Then, using the bimonthly *Physics Abstracts*, which also exists both in paper and in electronic form, you can look up the abstract of the paper and check whether it is of interest.

But by far the simplest and most efficient way to keep in touch with ongoing research on motion is with help of the *internet*, the international computer network. To anybody with a personal computer connected to a telephone, most theoretical physics papers are

available free of charge, as preprints, i.e. before official publication and check by referees. This famous service is available at the <http://www.arxiv.org> web site.

Table 69 The Los Alamos e-print archive system for physics and related topics

Topic	server name	server address
general relativity and quantum cosmology	gr-qc	via e-mail, add @xxx.lanl.gov or @babbage.sissa.it to the server name, e.g. hep-th@arXiv.org or gr-qc@xxx.lanl.gov or physics@babbage.sissa.it
theoretical high energy physics	hep-th	
computational high energy physics and lattice calculations	hep-lat @arxiv.org or	
phenomenological high energy physics	hep-ph	
experimental high energy physics	hep-ex	
general physics	physics	
theory, experiments and philosophy of quantum physics	quant-ph	
experimental nuclear physics	nucl-ex	
theoretical nuclear physics	nucl-th	
astrophysics	astro-ph	
condensed matter physics	cond-mat	
mathematical physics	math-ph	
mathematics	math	
computer science	CoRR	

For details on how to use these servers via electronic mail, send a message to the server with the subject line consisting simply of the word ‘help’, without the quotes.

In the last decade of the twentieth century, the internet expanded into a mix of library, media store, discussion platform, order desk and time waster. With a personal computer, a modem and free *browser* software you can look for information in millions of pages of documents. The various parts of the documents are located in various computers around the world, but the user does not need to be aware of this. *

* Decades ago, the provoking book by IVAN ILLICH, *Deschooling society*, Harper & Row, 1971, listed four basic ingredients for any educational system:

- access to *resources* for learning, e.g. books, equipment, games, etc. at an affordable price, for everybody, at any time in their life;
- for all who want to learn, access to *peers* in the same learning situation, for discussion, comparison, cooperation, competition;
- access to *elders*, e.g. teachers, for their care and criticism towards those who are learning;
- exchanges between student and *performers* in the field of interest, so that the latter can be models to the former. For example, there should be the possibility to listen to professional musicians, reading the works of specialists, as well as giving performers the possibility to share, to advertise, and to perform their skills.

Illich develops the idea that if such a system was informal, he then calls it a ‘learning web’ or ‘opportunity web’, it would be superior to any formal, state financed institutions, such as existing schools, for the development of mature human beings. The discussion is deepened in his following works, *Deschooling our lives*, Penguin, 1976, and *Tools for conviviality*, Penguin, 1973. Today, any networked computer offers one or more of the following: the simple *e-mail* (electronic mail), the more sophisticated *ftp* (file transfer to and from another computer), the more rare access to *usenet* (the discussion groups on specific topics, such as particle physics), and the powerful *world-wide web*. (Simply speaking, each of the latter implies and includes the ones before.) In a rather unexpected way, all these facilities of the internet could transform it into the backbone of the oppor-

To start using the web, ask a friend who knows, or send an electronic mail message consisting of the line 'HELP' to listserv@info.cern.ch, the server at the European Organisation for Particle Research, where the web was invented. * Searching the web for authors, organizations, books, publications, companies or simple keywords using search engines can be a rewarding experience. A few interesting servers are given below.

Table 70 Some interesting world wide web servers

Topic	web site address ('URL')
Search engines and more	
Good information search engines	http://www.altavista.com/cgi-bin/query?pg=aq http://www.metager.de
Search old usenet articles	http://groups.google.com
Information about the net	http://akebono.stanford.edu/yahoo/ http://cuiwww.unige.ch/w3catalog
Frequently asked questions on various topics, also on physics	http://www.faqs.org
Physics and science	
'The Internet Pilot to Physics'	http://www.tp.umu.se/TIPTOP
A complete physics information site, organized with help from the European Physical Society including an encyclopedia, preprints, news, forum, student forum, conferences, job market, used machines market, web links, etc.	
Electronic preprints	http://xxx.lanl.gov and others – see above http://www.slac.stanford.edu/spires
High energy physics	http://mentor.lanl.gov/Welcome.html or http://info.cern.ch/hypertext/DataSources/bySubject/Physics/HEP.html
Particle data	http://pdg.web.cern.ch/pdg
Physics news, weekly	http://www.aip.org
Article summaries in 25 science magazines	http://www.mag.browse.com/science.html
Abstracts of papers in physics journals	http://www.osti.gov
Science News	http://www.sciencenews.org
Pictures of physicists	http://www.if.ufrj.br/famous/physlist.html
Information on physicists	http://144.26.13.41/phyhist
Gravitation news	http://vishnu.nirvana.phys.psu.edu/mog.html
Living reviews in relativity	http://www.livingreviews.org
Information on relativity	http://math.ucr.edu/home/baez/relativity.html
Physics problems	http://star.tau.ac.il/QUIZ
Physics organizations	http://www.cern.ch/ http://info.cern.ch/

tunity web mentioned by Illich; it is a social development to follow closely. It depends on the user's discipline whether the world wide web actually does provide a learning web.

* To use ftp via electronic mail, send a message to archie@archie.mcgill.ca with 'help' as mail text. To get web pages via e-mail, send an e-mail message to w3mail@gmd.de consisting of the word 'help', or, for general instructions, to mail-server@rtfm.mit.edu with as body 'send usenet/news.answers/internet-services/access-via-email'.

Topic	web site address ('URL')
	http://aps.org
	http://www.hep.net/documents/newsletters/pnu/pnu.html
	http://www.aip.org
	http://www.nikhef.nl/www/pub/eps/eps.html
	http://www.het.brown.edu/physics/review/index.html
Physics textbooks on the web	http://www.plasma.uu.se/CED/Book
	http://biosci.umn.edu/biophys/OLTB/Textbook.html
Three beautiful French sets of notes on classical mechanics and particle theory	http://www.phy.ulaval.ca/enote.html
Physics lecture scripts in German and English	http://kbibmp5.ub.uni-kl.de/Linksammlung/Physik/liste.html
Math forum internet resource collection	http://mathforum.org/library/
Math formulas	http://dlmf.nist.gov
Libraries	http://www.konbib.nl
	http://portico.bl.uk
	http://portico.bl.uk/gabriel/en/services.html
	http://www.niss.ac.uk/reference//opacsalpha.html
	http://www.bnf.fr
	http://www.laum.uni-hannover.de/iln/bibliothek/kataloge.html
	http://www.loc.gov
	http://lcweb.loc.gov
Publishers	http://www.ioppublishing.com/
	http://www.aip.org
	http://www.amherts.edu/~ajp
	http://www.elsevier.nl/
	http://www.nature.com/
Computers	
File conversion	http://tom.cs.cmu.edu/intro.html
Download software and files	http://www.filez.com
Symbolic integration	http://www.integrals.com
	http://http.cs.berkeley.edu/~fateman/htest.html
Curiosities	
NASA	http://oel-www.jpl.nasa.gov/basics/bsf.html
	http://gsfc.nasa.gov
Hubble space telescope	http://hubble.nasa.gov
The cosmic mirror	http://www.astro.uni-bonn.de/dfischer/mirror
Solar system simulator	http://space.jpl.nasa.gov
Observable satellites	http://liftoff.msfc.nasa.gov/RealTime/JPass/20/
The earth from space	http://www.visibleearth.nasa.gov
Optical illusions	http://www.sandlotscience.com
Petit's science comics	http://www.jp-petit.com/science/index.html
Physical toys	http://www.e20.physik.tu-muenchen.de/~cucke/toylink.htm
Physics humour	http://www.escape.ca/~dcc/phys/humor.htm
Literature on magic	http://www.faqs.org/faqs/magic-faq/part2/
Algebraic surfaces	http://www.mathematik.uni-kl.de/~hunt/drawings.html

Topic	web site address ('URL')
Making paper aeroplanes	http://pchelp.inc.net/paper_ac.htm
Postmodern culture	http://www.ivic.qc.ca/~aleexpert/aluniversite/klinevogelmann.html
Pseudoscience	http://jefferson.village.virginia.edu/pmc/contents.all.html
Crackpots, English language	suhep.phy.syr.edu/courses/modules/PSEUDO/pseudo_main.html
Mathematical quotations	www.crank.net
The World Question Center	http://math.furman.edu/~mwoodard/mquot.html
	http://www.edge.org

Do you want to study physics without actually going to university? Nowadays it is possible to study via e-mail and internet, in German, at the University of Kaiserslautern. * In the near future, a nationwide project in Britain should allow the same for English speaking students. As introduction, use the last update of this physics text.



Si tacuisses, philosophus mansisses.**
After Boethius.

* See the <http://www.fernstudium-physik.de> web site.

** 'If you had kept quiet, you would have remained philosopher.' After the story Boethius tells in *De consolatioe philosophiae*, 2,7, 67 ff.

APPENDIX F LIST OF FIGURES

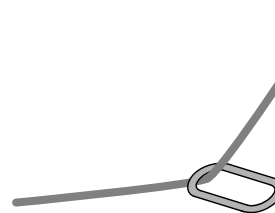

Figure 1	An example of motion observed in nature	25
Figure 2	Motion Mountain and the trail to be followed	26
Figure 3	Illusion of motion: fake rotation	27
Figure 4	How much water makes a bucket hang vertically? In which direction does the reel move when pulled at an angle?	28
Figure 5	A typical path followed by a stone thrown through the air	40
Figure 6	Two proofs of the three-dimensionality of space: a knot and the inner ear of a mammal	45
Figure 7	A curvemeter or odometer	47
Figure 8	A fractal: a selfsimilar curve of infinite length, and its construction	48
Figure 9	Polyhedra and dihedral angles	49
Figure 10	How the apparent size of the moon and the sun changes	51
Figure 11	Various types of graphs describing the same flying stone	53
Figure 12	Derivatives	53
Figure 13	Betelgeuse	56
Figure 14	How an object can rotate without tangling up the connection to a second one	58
Figure 15	Legs and wheels in living beings	58
Figure 16	In which direction does the bicycle turn?	60
Figure 17	Collisions define mass	60
Figure 18	Is this dangerous?	61
Figure 19	What happens?	64
Figure 20	Angular momentum	69
Figure 21	How a snake turns itself around its axis	70
Figure 22	The velocities and unit vectors for a rolling wheel	70
Figure 23	A simulated photograph of a rolling wheel with spokes	71
Figure 24	The parallax - obviously not drawn to scale	71
Figure 25	Earth's deviation from spherical shape due to its rotation	72
Figure 26	The deviations of free fall towards the east and towards the equator, both due to the rotation of the earth	72
Figure 27	The motion of a pendulum on the rotating earth	74
Figure 28	A gyroscope	74
Figure 29	Showing the rotation of the earth through the rotation of an axis	75
Figure 30	Changes in the earth's motion around the sun	77
Figure 31	The motion of the sun around the galaxy	78

Figure 32	Momentum seems not to be conserved in this situation	80
Figure 33	How does the ladder fall?	80
Figure 34	Observation of sonoluminescence with a diagram of the experimental set-up	80
Figure 35	How does the ball move when the jar is moved?	81
Figure 36	The famous Celtic stone	81
Figure 37	How does the ape move?	82
Figure 38	A basilisk lizard (<i>Basiliscus basiliscus</i>) running over water	83
Figure 39	A physicist's and an artist's view of the fall of the moon: a graph by Christiaan Huygens and a marble by Auguste Rodin	85
Figure 40	The potential and the gradient	87
Figure 41	The motion of a planet around the sun, showing its semimajor axis d , which is also the spatial average of its distance from the sun	89
Figure 42	The possible orbits due to universal gravity	91
Figure 43	The two stable Lagrangian points	92
Figure 44	Tidal deformations due to gravity	93
Figure 45	The origin of tides	94
Figure 46	Particles falling side by side approach over time	94
Figure 47	Masses bend light	95
Figure 48	Brooms fall more rapidly than stones	97
Figure 49	A honest balance?	98
Figure 50	Which of the two moon paths is correct?	98
Figure 51	The vanishing of gravitational force inside a spherical shell of matter	99
Figure 52	Shapes and air resistance	106
Figure 53	What shape of rail allows the black stone to glide most rapidly from point A to the lower point B?	113
Figure 54	Can motion be described in a manner common to all observers?	113
Figure 55	What happens when one rope is cut?	114
Figure 56	How to draw a straight line with a compass: fix point F, put a pencil into joint P, and move C with a compass along a circle	114
Figure 57	Why do balloons stay inflated? How do you measure the weight of a bicycle rider with a ruler only?	115
Figure 58	How and where does a falling brick chimney break?	115
Figure 59	What determines the number of petals in a daisy?	115
Figure 60	Defining a total effect by adding up over time	118
Figure 61	The minimum of a curve has vanishing slope	119
Figure 62	Aggregates in nature	124
Figure 63	Refraction of light is due to travel time optimization	127
Figure 64	Forget-me-not, also called <i>myosotis</i> (Borraginaceae)	127
Figure 65	A Hispano-Arabic ornament from the Governor's Palace in Sevilla	131
Figure 66	The simplest oscillation	140
Figure 67	Floors and mountains as fractals	142
Figure 68	Atomic steps in broken gallium arsenide crystals seen under a conventional light microscope	144
Figure 69	The principle and the realization of an atomic force microscope	146
Figure 70	The surface of a silicon crystal mapped with an atomic force microscope	146
Figure 71	A typical path for a particle undergoing Brownian motion, its displacement distribution, and its average square displacement	150

Figure 72	The basic idea of statistical mechanics about gases	151
Figure 73	Which balloon wins?	152
Figure 74	Are you able to boil water in this paper cup?	158
Figure 75	The Ranque-Hilsch vortex tube	160
Figure 76	Examples of self-organization for sand	160
Figure 77	An oscillon formed by shaken bronze balls	161
Figure 78	Magic numbers of spheres swirled in a dish	162
Figure 79	Examples of different types of motion in configuration space	163
Figure 80	Sensitivity to initial conditions	163
Figure 81	The rain method of measuring the speed of light	169
Figure 82	A photograph of a light pulse moving from right to left through milky water, taken by Dugay and Mattick	170
Figure 83	The set-up for the observation of the Doppler effect	173
Figure 84	Lucky Luke	176
Figure 85	Experimental values (dots) for the electron velocity v as function of kinetic energy T	176
Figure 86	Two inertial observers, using coordinates (t, x) and (τ, ξ) , and a beam of light	178
Figure 87	Space-time diagrams for light seen from two different observers	179
Figure 88	A space-time diagram of an object T seen from an inertial observer O in the case of one and of two spatial dimensions	181
Figure 89	The observations of the trap digger and of the snowboarder	184
Figure 90	Does the conducting glider keep the lamp lit at large speeds?	185
Figure 91	What happens to the rope?	185
Figure 92	For the athlete on the left, the judge moving in the opposite direction sees both feet off the ground at certain times, but not for the athlete on the right	186
Figure 93	A simple example of motion that is faster than light	187
Figure 94	Another example of faster than light motion	187
Figure 95	Hypothetical space-time diagram for tachyon observation	188
Figure 96	If O's stick is parallel to R's, and R's is parallel to G's, then O's stick and G's stick are not	189
Figure 97	An inelastic collision of two identical particles seen from two different inertial frames of reference	190
Figure 98	A useful rule for playing non-relativistic pool	191
Figure 99	The dimensions of detectors in particle accelerators are based on the relativistic pool angle rule	192
Figure 100	Space-time diagram of two interacting particles	194
Figure 101	There is no way to define a centre of mass	196
Figure 102	The space-time diagram of a moving object T	197
Figure 103	Energy-momentum is tangent to the world line	199
Figure 104	On the definition of relative velocity	201
Figure 105	Observers on a rotating object	201
Figure 106	Simplified situation for an inertial and an accelerated observer	205
Figure 107	The hyperbolic motion of an rectilinearly, uniformly accelerating observer and its event horizons	207
Figure 109	Clocks and the measurement of the speed of light as two-way velocity	211
Figure 108	Do accelerated objects depart from inertial ones?	214
Figure 110	Colours inside an accelerating train or bus	234

Figure 111	The necessity of blue and redshift of light: why trees are greener at the bottom	235
Figure 112	Tidal effects: what bodies feel when falling	238
Figure 113	The path of a light beam and of a satellite near a spherical mass	240
Figure 114	All paths of flying stones have the same curvature in space-time	245
Figure 115	The Thirring and the Thirring-Lense effects	252
Figure 116	The reality of gravitomagnetism	253
Figure 117	A Gedankenexperiment showing the necessity of gravity waves	255
Figure 118	Effects on a circular or spherical body of a plane gravitational wave moving vertically to the page	256
Figure 119	Comparison between measured time delay in the periastron of the binary pulsar PSR 1913+16 and the prediction due to energy loss by gravitational radiation	258
Figure 120	Detection of gravitational waves	258
Figure 121	Calculating the bending of light by a mass	259
Figure 122	The orbit around a central body in general relativity	262
Figure 123	The geodesic effect	263
Figure 124	Positive, vanishing and negative curvature in two dimensions	264
Figure 125	Curvature (in two dimensions) and geodesic behaviour	266
Figure 126	How our galaxy looks in the infrared	281
Figure 127	A few galaxies: the Andromeda nebula M31, a spiral galaxy, the elliptical galaxy NGC 205, and the colliding galaxies M51, also known as NGC 5194	282
Figure 128	The ranges for the Ω parameters and their consequences	291
Figure 129	The evolution of the universe's scale R for different values of its mass density	292
Figure 130	The long term evolution of the universe's scale a for various parameter combinations	293
Figure 131	The absorption of the atmosphere	300
Figure 132	How one star can lead to several images	302
Figure 133	The Zwicky-Einstein ring B1938+666 and multiple galaxy images around CL0024+1654	303
Figure 134	A 'hole' in space	313
Figure 135	The light cones in the equatorial plane around a non-rotating black hole, seen from above	316
Figure 136	Motion of uncharged objects around a nonrotating black hole	317
Figure 137	Motion of <i>light</i> passing near a non-rotating black hole	318
Figure 138	The ergosphere of a rotating black hole	320
Figure 139	Motion of some light rays from a dense body to an observer	322
Figure 140	How to amaze kids	340
Figure 141	Lightning: a picture taken with a moving camera, showing the multiple strokes it consists of	342
Figure 142	A simple Kelvin generator	342
Figure 143	Franklin's personal lightning rod	343
Figure 144	Consequences of the flow of electricity	348
Figure 145	An ancient and a modern version of an electric motor	349
Figure 146	An electrical current always produces a magnetic field	350
Figure 147	The relativistic aspect of magnetism	353
Figure 148	The first of Maxwell's equations	354
Figure 149	The second of Maxwell's equations	354
Figure 150	Vector potentials for selected situations	356

Figure 151	Charged particles after a collision	358
Figure 152	Which one is the original landscape?	360
Figure 153	The light power transmitted through a slit as function of its width	364
Figure 154	Sugar water bends light	368
Figure 155	Light beams can spiral around each other	369
Figure 156	Masses bend light	370
Figure 157	Levitating a small glass bead with a laser	370
Figure 158	A commercial light mill turns <i>against</i> the light	371
Figure 159	Light can rotate objects	372
Figure 160	Proving that white light is a mixture of colours	373
Figure 161	The definition of important velocities in wave phenomena	374
Figure 162	Unipolar motor	380
Figure 163	Capacitors in series	380
Figure 164	Small neon lamps on a high voltage cable	381
Figure 165	The path of light for dew on grass responsible for the aureole	384
Figure 166	A limitation of the eye	385
Figure 167	What is the shade of the crossings?	385
Figure 168	Do you see white, grey, or black dots?	386
Figure 169	Eyes see inverted images	386
Figure 170	A high quality photograph of a live human retina	387
Figure 171	The structure of our planet	388
Figure 172	Floating 'magic' nowadays available in toy shops	391
Figure 173	Trapping a metal sphere using a variable speed drill and a plastic saddle	391
Figure 174	Hot bodies in a hot oven	400
Figure 175	Devices for the definition of sets (left) and of relations (right)	429
Figure 176	The surreal numbers in conventional and in bit notation	437
Figure 177	An example of a quantum system	480
Figure 178	An (average) water particle	483
Figure 179	Hills are never high enough	488
Figure 180	Leaving enclosures	488
Figure 181	Identical objects with crossing paths	489
Figure 182	Transformation through reaction	489
Figure 183	How do train windows manage to show two superimposed images?	490
Figure 184	A particle and a screen with two nearby slits	490
Figure 185	Illumination by pure-colour light	492
Figure 186	Observation of photons	492
Figure 187	Various types of light	496
Figure 188	How to measure photon statistics	498
Figure 189	The kinetic energy of electrons emitted in the photoelectric effect	498
Figure 190	Light crossing light	500
Figure 191	Interference and the description of light with arrows (at one particular instant of time)	501
Figure 192	Light reflected by a mirror and the corresponding arrows (at one particular instant of time)	502
Figure 193	Light reflected by a badly placed mirror and by a grating	503
Figure 194	If light were made of little stones, they would move faster inside water	503

Figure 195	A falling pencil	506
Figure 196	Steps in the flow of electrons	507
Figure 197	The spectrum of daylight: a section of the rainbow	510
Figure 198	The result of moving atoms one by one on a metal surface	514
Figure 199	Identical objects with crossing paths	521
Figure 200	Particles as localized excitations	524
Figure 201	An argument showing why rotations by 4π are equivalent to no rotation	528
Figure 202	A belt visualizing spin 1/2	530
Figure 203	The human arm as spin 1/2 model	530
Figure 204	Another spin 1/2 model	530
Figure 205	The extended belt trick, modelling a spin 1/2 particle: the two situations can be transformed into each other either by rotating the central object by 4π or by keeping the central object fixed and moving the bands around it	531
Figure 206	Some visualizations of spin representations	532
Figure 208	Belts in space-time: rotation and antiparticles	534
Figure 207	Equivalence of exchange and rotation in space-time	534
Figure 209	Artist's impression of a macroscopic superposition	539
Figure 210	Quantum mechanical motion: an electron wave function (actually its module squared) from the moment it passes a slit until it hits a screen	547
Figure 211	Bohm's Gedankenexperiment	548
Figure 212	A system showing probabilistic behaviour	550
Figure 213	The concepts used in the description of measurements	551
Figure 214	Myosin and actin: the building bricks of a molecular motor	560
Figure 215	Two types of Brownian motors: switching potential (left) and tilting potential (right)	561
Figure 216	What is the maximum possible value of h/l ?	583
Figure 217	QED as perturbation theory in space-time	588
Figure 218	The weakness of gravitation	590
Figure 219	A <i>Gedankenexperiment</i> allowing to deduce the existence of black hole radiation	593
Figure 220	An electrometer in a charged and in an uncharged state	617
Figure 221	The Dyson-Feynman graphs building the Lagrangians of the weak interactions	620
Figure 222	Displacement of a particle by appropriate twisting of worms	639
Figure 223	A typical particle spectrum predicted by string theory	643
Figure 224	How the description of motion proceeded in the history of physics	654
Figure 225	Ciliated and flagellate motion	661
Figure 226	One way to turn a sphere inside out	665
Figure 227	The simplest knots	665
Figure 228	'Tekenen' by M.C. Escher, 1948 – a metaphor for the way in which 'particles' and 'space-time' are usually defined: each with help of the other	672
Figure 229	A <i>Gedankenexperiment</i> showing that at Planck scales, matter and vacuum cannot be distinguished	686
Figure 230	Coupling constants and their spread running with energy	694
Figure 231	Measurement errors as a function of measurement energy	705
Figure 232	Trees and galaxies	707
Figure 233	Speed and distance of remote galaxies	707
Figure 234	A <i>Gedankenexperiment</i> showing that at Planck scales, matter and vacuum cannot be distinguished	729

- Figure 235 A property of triangles easily provable with complex numbers
Figure 236 Combinations of rotations

843
845

Picture credits

All pictures are copyright © 1997, 1998, 1999, 2000, 2001, 2002 by Christoph Schiller

APPENDIX G LIST OF TABLES



Table 1	What one can find about motion in a library	29
Table 2	Family tree of the basic physical concepts	35
Table 3	Properties of Galilean velocity	38
Table 4	Some velocity measurements	39
Table 5	Some time measurements	41
Table 6	Properties of Galilean time	42
Table 7	Properties of Galilean space	45
Table 8	Some distance measurements	46
Table 9	Some acceleration values found in nature	55
Table 10	Properties of Galilean mass	63
Table 11	Some mass values	63
Table 12	Some power measurements	67
Table 13	Correspondence between linear and rotational motion	68
Table 14	Some rotation speeds	69
Table 15	One of the mysteries of physics: planet distances and the values resulting from the Titius-Bode rule	101
Table 16	A selection of processes and devices changing the motion of bodies	105
Table 17	Some action values for changes either observed or imagined	117
Table 18	The main aggregates observed in nature	124
Table 19	Correspondences between the symmetries of an ornament, a flower and nature as a whole	133
Table 20	The symmetries of relativity and quantum theory with their properties; at the same time, the complete list of logical <i>inductions</i> used in the two fields	137
Table 21	Some temperature measurements	148
Table 22	Extensive quantities in nature, i.e. quantities which <i>flow</i> and <i>accumulate</i>	152
Table 23	Some typical entropy values per particle at <i>standard</i> temperature and pressure as multiples of the Boltzmann constant	153
Table 24	Properties of the motion of light	170
Table 25	The expected spectrum of gravitational waves	254
Table 26	Some observations about the universe	283
Table 27	A short history of the universe	287
Table 28	The colour of the stars	301
Table 29	Present types of tests of general relativity	327
Table 30	Some searches for magnetic monopoles, i.e., for magnetic charges	341
Table 31	Some observed magnetic fields	341

Table 32	Properties of classical electric charge	345
Table 33	Values of electrical charge observed in nature	345
Table 34	Some observed electric fields	346
Table 35	The electromagnetic spectrum	366
Table 36	Experimental properties of the aether and of flat vacuum	378
Table 37	Selected matter properties related to electromagnetism, showing among others the role it plays in the constitution of matter; at the same time a short overview of atomic, solid state, fluid and business physics	392
Table 38	Some examples of disastrous motion of possible future importance	411
Table 39	Semantic primitives, following Anna Wierzbicka	426
Table 40	The defining properties of a set	430
Table 41	Some large numbers	435
Table 42	Some small systems in motion and the observed action values for the changes they undergo	484
Table 43	Irreducible representations of the rotation group	529
Table 44	Some common and less common baths with their main properties	541
Table 45	Signals penetrating mountains	571
Table 46	A few comparisons between quantum theory and experiment	645
Table 47	<i>Everything</i> quantum field theory and general relativity do <i>not</i> explain; in other words, a list of <i>the only</i> experimental data and criteria available for tests of the unified description of motion.	653
Table 48	A tiny selection of the consequences of changing the properties of nature	655
Table 49	The size, Schwarzschild radius, and Compton wavelength of some objects appearing in nature	674
Table 50	Physical properties of the universe	717
Table 51	Properties of nature at maximal, everyday and minimal scales	718
Table 53	<i>Everything</i> quantum field theory and general relativity do <i>not</i> explain; in other words, a list of <i>the only</i> experimental data and criteria available for tests of the unified description of motion.	727
Table 54	A tiny selection of the consequences of changing aspect of nature	728
Table 55	Effects of various camera shutter times	736
Table 56	Properties of nature that any fundamental model must describe	759
Table 57	The derived SI units of measurement	812
Table 58	The SI unit prefixes	813
Table 59	Planck's natural units	815
Table 60	Basic physical constants	820
Table 61	Derived physical constants	821
Table 62	Astrophysical constants	822
Table 63	Astronomical constants	823
Table 64	The elementary particles	827
Table 65	Elementary particle properties	828
Table 66	Properties of selected composites	830
Table 67	Periodic table of the elements	834
Table 68	The elements and their main properties	835
Table 69	The Los Alamos e-print archive system for physics and related topics	859
Table 70	Some interesting world wide web servers	860

APPENDIX H CHALLENGE HINTS AND SOLUTIONS



Let me know the challenge for which you want a hint or a solution to be given here; I will mail it to you and include it in the text in the future.

Challenge ...on **143**: The height to which an animal can jump is given by the ratio between its mass, which is proportional to the length l cubed, and its leg muscle strength, which is proportional to l^2 times their length l .

Challenge ...on **80**: The atomic force microscope.

Challenge ...on **850**: For a gaussian integer $n + im$ to be prime, the integer $n^2 + m^2$ must be prime, and in addition, a condition on $n \bmod 3$ must be satisfied; which one and why?

This is a section of the freely downloadable e-textbook

Motion Mountain

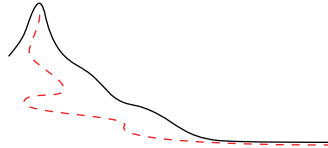

Hiking beyond space and time along the concepts of modern physics

available at
www.motionmountain.org

Copyright © 1997, 1998, 1999, 2000, 2001, 2002 by Christoph Schiller

To the kind reader

In exchange for getting this section for free, I ask you for a short email on some of the following:

- Which page was boring?
- Did you find any mistakes?
- What else were you expecting?
- What was hard to understand?

Of course, any other suggestion is welcome. This section is part of a physics text written over many years. The text lives and grows through the feedback from its readers, who help to improve and to complete it. For a particularly useful contribution (send it in english, italian, dutch, german, spanish, portuguese, or french) you will be mentioned in the foreword of the text, or receive a small reward, or both.

Enjoy!

Christoph Schiller
cs@motionmountain.org

Challenge 1122

APPENDIX I SUBJECT AND NAME INDEX

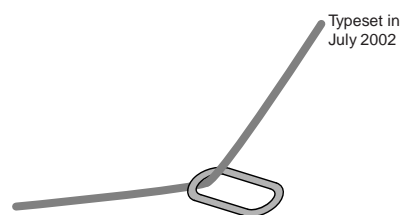

Page numbers in ordinary typeface refer to pages where the keyword is used or the name mentioned. Page numbers in *italic* typeface refer to pages where the keyword is defined or presented in detail. The index thus also works as glossary.

Typeset in
July 2002

Symbols

π 200
 BaO_2 392
 CaF_2 395
 CeF_3 393
 KPO_4 395
 LiNbO_3 395
 BaTiO_3 393
 CsNO_3 394
't Hooft, Gerard 682
(mathematical) knot 663
(mathematical) points 45
(physical) action 115
(physical) power 66
(plane) waves 361
*-algebra 854
..., ... 216, 227, 476, 549, 604, 629, 667, 757, 824
alpha 804
beta 804
chi 804
delta 804
digamma 804
epsilon 804
eta 804
gamma 804
iota 804
kappa 804
lambda 804
mu 804
nu 804
omega 804

omicron 804
phi 804
pi 804
psi 804
qoppa 804
rho 804
sampi 804
sigma 804
tau 804
theta 804
upsilon 804
xi 804
zeta 804

4

4-acceleration 197
4-coordinates 179, 195, 197
4-jerk 198
4-momentum 198
4-vector 197
4-velocity 197

A

α -rays 167
a posteriori 427
a priori 427
a priori concepts 417
abacus 807
Abbott, T.A. 405
Abddalla, M.C.B. 720
abelian, or commutative 129
aberration 72, 77, 168

Abramowicz, M.A. 335
absolute value 843
absoluteness 42, 45
absorption 394
abstraction 433
acausal 181, 545
acausality 109
accelerating frames 205
acceleration 55, 229
acceleration, proper 205
acceleration, uniform 206
accents, in Greek language 806
accretion 322
accumulability 344
accumulation 151
accuracy 165, 819
accuracy, maximal 704
acoustical thermometry 226
acoustoelectric effect 391
acoustomagnetic effect 392
acoustooptic effect 395
Aquarius 98
actin 561
actinium 835
actinoids 834
action 115, 132, 645
Adams, Douglas 463, 658, 716
addition 129, 433
addition theorem for
 accelerations 208
additivity 38, 42, 45, 63, 344

- additivity of area and volume
 48
 Adenauer, Konrad 96
 adenosine triphosphate 561
 adenosinetriphosphate 219
 adjoint 854
 adjoint representation 855
 adjunct 524
 Adler, Carl G. 231
 ADM mass 272, 713
 Aedini, J. 515
 aeroplanes 62
 aether 377, 404, 446, 678
 aether models 404
 Aflatooni, K. 517
 AFM, atomic force microscope
 145
 AgBr 394
 AgCl 395
 age 292
 age of the universe 701
 age of universe 195
 aggregates of matter 121
 AgI 394
 aging 488
 agoraphobics 290
 Aharonov, Y. 516
 Ahluwalia, D.V. 696
 Ahrens, C.D. 224
 Aigler, M. 49
 air 299, 391
 air in universe 296
 air pressure 65
 Aitken, M.J. 407
 Ajdari, A. 407
 Akerboom, F. 402
 Akerman, N. 105
 al-Hadi al-Hush, Ramadan 472
 albedo 369
 Albert Einstein 274
 alchemy 37
 Aldebaran 125, 300
 Alexander, R. McN. 221
 algebra 853
 algebraic structure 432
 algebraic surfaces 861
 algebraic system 432
 Ali, A. 720
 Alice in Wonderland 155
 Alighieri, Dante 83
 alkali metals 834
 Allen, L. 402
 Allen, Les 402
 Allen, Woody 284, 420, 796
 Alnilam 300
 Alnitak 300
 Alpha Centauri 124
 alpha decay 285
 alphabet 804
 Alps 88, 100
 Alspector, J. 228
 Altair 124, 300
 Alvarez Menendez, Valentin 18
 alternative 849
 Altman, S.L. 857
 aluminium 400, 835
 Alväger, T. 228
 Amaldi, U. 698, 757
 Amati, D. 697
 amber 339
 Amelino-Camelia, G. 696, 698
 Amenomori, 629
 americium 835
 ampere 811
 amplitude 361
 Ampère 352
 Ampère, André-Marie 348
 An, K. 226, 606
 anapole moment 626
 Anaxagoras 472
 Anaxagoras of Clazimenes 793
 Anders, S. 222
 Anderson, ... 331
 Anderson, C.D. 510
 Anderson, M.H. 516
 Anderson, R. 220
 Andres, M.R. 603
 Andromeda nebula 280, 285
 angel 447
 angels 29, 60, 434, 530, 647
 angle 68
 angular acceleration 68
 angular frequency 361
 angular momentum 67, 68, 81,
 349, 371, 532, 645
 angular momentum of light
 370
 angular momentum, extrinsic
 68
 angular velocity 67, 68
 anholonomic 119
 animism 417
 Anıçin, I.V. 222
 annihilation 296, 391
 annihilation operator 524
 annihilation operators 633
 Antares 125
 anthropic principle 467, 726
 anti-atoms 833
 anti-bunching 497
 anti-hermitean 131
 anti-theft etiquettes 392
 anti-unitary 131
 anticommutator bracket 524
 antigravity 92
 antihydrogen 831
 antimatter 64, 194, 276, 296
 antimony 835
 antiqua 806
 antisymmetric tensor 349
 antisymmetry 131, 854
 Anton, A. 515
 anyons 534, 534
 apes 617, 726
 apogee 823
 Apollo 176
 apparatus 554
 apparatus, classical 554
 apparatus, irreversible 554
 apple 819
 apple, standard 819
 apples 60, 249, 444, 819
 Aquinas, Thomas 531
 Ar 392
 Arago, François 368
 Archeozoic 287
 Archimedes 60
 arcs 342
 Arcturus 125
 Ardenne, Manfred von 391
 argentum 839
 argon 835
 argument 431
 Aries 98
 Aripov, Otanzar 472
 Aristarchos 220
 Aristarchos of Samos 72, 76,
 168
 Aristotelian view 103

- Aristotle 38, 43, 85, 218, 454, 458
 Arlt, J. 402
 arm 529, 845, 846
 Armstrong, J.T. 219
 Arndt, M. 516
 Arrowitt 272
 Aronson, Jeff 19
 Aronson, Jeff K. 824
 arrow of time 43
 Arsenau, Donald 19
 arsenic 835
 artefact 58, 812
 artefacts 463
 Ascher, Marcia 433
 Ashby, M.F. 225
 Ashcroft, N. 609
 Ashcroft, Neil 396
 Ashkin, A. 402
 Ashkin, Arthur 370
 Ashtekar, A. 337, 695, 758
 Askin, A. 402
 Aspect, Alain 546, 603
 aspects 417
 Aspinwall, P. 697
 associative algebra 853
 associativity 129
 astatine 835
 asteroid hitting the earth 410
 asteroid, Trojan 92
 asteroids 99, 125
 Astrid, an atom 225
 astrology 89, 98, 99
 astronomers, smallest known 90
 astronomical unit 100
 astronomy 846
 astrophysics 859
 Astumian, R.D. 604
 asymptotically free 631
 at-sign 803
 atmosphere of the moon 158
 atom 116 831
 Atom lifetime 646
 atomic 818
 atomic force microscope 145, 872
 atomic force microscopes 106
 atomic mass unit 830
 atomic number 834
 atomic radius 840
 atoms 21, 287, 480
 atoms are indivisible 157
 atoms are not indivisible 157
 atoms, hollow 585
 atoms, single 144
 ATP 219, 561, 831
 ATP synthase 560
 Audoin, C. 824
 Auger effect 396
 aureole 383
 aurum 836
 Ausloos, M. 225
 autism 415, 473
 autistics 415, 473
 average 120, 451, 543, 690
 average curvature 269
 Avogadro's number 821
 Avogadro, Amadeo 144
 Avron, J.E. 404
 awe 464, 657
 Awschalom, D.D. 603
 Axelrod, R. 214
 axiom of choice 428
 axioms 433
 axis 219
 axis, earth's 77
- B**
 β -rays 167
 Babinet, Jacques 812
 Babloyantz, A. 225
 Babylonia 807
 Bachem 235
 background 33, 35, 44, 180
 background radiation 285, 288, 293, 296
 bacteria 58, 567
 bacterium 67
 Baez, J. 758
 Baez, John 19, 757
 Baggett, N. 228
 Bagnoli, Franco 19
 Bailey, J. 229
 Bailey, J.M. 228
 Balachandran, A.P. 695
 Balashov, Yuri I. 476
 ball lightning 382
 balloons 150
 Banach 141
 Banach measure 48
 Banach, Stefan 48, 49
 Banach-Tarski paradox 679
 Banach-Tarski theorem 49, 680, 722
 Banavar, J.R. 225
 Bandler, R. 214
 Bandler, Richard 111, 214, 414, 442
 Barber, B.P. 221
 Barbour, Julian 334
 Bardeen, John 603
 barium 835
 Barlow's wheel 378
 Barnett, S.J. 400
 Barnhill, M.V. 400
 barometer light 391
 Barrow, J.D. 334
 Barrow, John D. 476, 655
 Barton, G. 606
 Bartussek, R. 604
 Barwise, J. 475
 barycentric coordinate time 330
 barycentric dynamical time 247
 base units 811
 basic units 844
 Basieux, Pierre 474
 Basiliscus basiliscus 83, 864
 basilisk 82
 basis 852, 855
 Basri, G. 333
 Batelaan, H. 517
 bath 539
 bath, physical 421, 539
 bath-tub vortex 220
 Baudelaire, Charles 28
 Baumann, K. 603
 Baylor, D.A. 515
 BCE 808
 Beale, I.L. 401
 Beaty, William 19
 beauty 159, 161
 beauty, origin of 159
 Bechinger, C. 607
 becquerel 812
 Bedford, D. 331
 Beenakker, C.W.J. 401, 604
 beer 395

- beetle 264
 beetle, click 82
 Before Common Era 808
 beginning of the universe 285
 beginning of time 285, 702
 behaviour 29
 Behroozi, C.H. 216
 Bekenstein, J.D. 335, 757
 Bekenstein, Jakob 159, 320, 592, 607
 Belic, D. 825, 841
 belief 444, 657, 789
 beliefs 30
 Belinfante, F.J. 535
 Bell's equation 553, 553
 Bell, J.S. 604
 Bell, John 553
 Bellatrix 300
 Bellini, Giovanni 405
 bells 530
 belt 846
 belt trick 528
 Benbrook, James 382
 Benjamin, J. 477
 Benka, S. 219
 Bennet, C.L. 221, 334
 Bennett, C.H. 407, 474, 730
 Bennett, Charles H. 226
 Benzenberg, Johann Friedrich 73
 BeppoSAX satellite 595
 Berg, E. 404
 Berg, H.C. 666
 Bergmann, L. 476
 Bergquist, J. 825
 Bering, Edgar 382
 Berkeley, George 456
 berkelium 835
 Berlekamp, E.R. 475
 Berlin, Brent 403
 Bernard, C. 629
 Bernoulli, J. 802
 Bernreuther, W. 698
 Bernstein, Aaron 376
 Berry, M.V. 406, 535
 Bertotti, I. Ciufolini, P.L.
 Bender, B. 332
 Bertozzi, Cyrus H. 216
 beryllium 835
 Bessel 569, 605
 Bessel functions 76
 Bessel, F.W. 293
 Bessel, Friedrich Wilhelm 76
 Betelgeuse 125, 300, 410
 Beth, R. 402
 bets 75
 Bettelheim, Bruno 473
 Bettermann, D. 405
 Beuys, Joseph 418, 470, 477
 Bharucha, C.F. 605
 Bi 393
 bible 447, 450
 Bierce, Ambrose 567
 big bang 293, 296, 297
 big brother 431
 Biggar, Mark 19
 bike 211
 Bilaniuk, O.M. 230
 Bilanuk, O.M.P. 230
 Bilger, H.R. 220
 billiards 61, 190
 Bimonte, G. 695
 bimorphs 104
 binary operation 432
 binary pulsars 247, 261
 biological clone 526
 biological evolution 29, 160
 biology 104, 830
 bioluminescence 395
 biphoton 498
 BIPM 450, 811
 Bird, David J. 825
 birds 21, 624
 Birds appear 288
 birefringence 394
 birefringent 363
 Birkhoff 275
 Bischoff, Bernard 809
 BiSeTe 391
 bismuth 831, 835
 bits 419
 Bjorkholm, J.E. 402
 Björk, G. 515
 black body 397
 black body radiation 299, 396, 397
 black hole 257, 299, 314, 672
 black hole radiation 334
 black hole, entropy of 320
 black hole, extremal 318
 black hole, Kerr 318
 black hole, primordial 322
 black hole, rotating 318
 black hole, Schwarzschild 318
 black hole, stellar 323
 black holes 109, 240, 314, 329, 656
 black holes as limit systems 325
 black holes do not exist 321
 black paint 293
 black vortices 319
 blackness 394
 Blagden 157
 Blair, David 241
 Blanché, ... 477
 Blandford, R. 335, 696
 blasphemies 505
 blasphemy 463
 Blau, Stephen 181
 Blau, Steven K. 229
 blinks 435
 Bliss, G.W. 405
 Bloch, Felix 629
 Block, S.M. 604
 blood 21
 blood pressure 146
 blood supply 57
 blue 366
 blue shift 173
 Boamfa, M.I. 405
 board divers 70
 boat 64, 168
 Bode's rule 100
 Bode, Johann Elert 100
 bodies, rigid 112
 body 34
 body, rigid 211
 body, solid 211
 Boer, W. de 698, 757
 Boersma, S.L. 606
 Boethius 862
 Bohm 715
 Bohm, D. 516
 Bohm, David 546, 603
 Bohr 504
 Bohr, N. 516
 Bohr, Niels 437, 537, 555, 573, 603, 835
 bohrium 835

- Boltzmann constant *149, 543*
 Boltzmann's constant *397*
 Boltzmann, Ludwig *119, 149*
 bomb *191*
 Bombelli, L. *336, 697, 757*
 Bombelli, Luca *18, 19, 695*
 bombs *596*
 Bombus terrestris *660*
 Bondi, H. *329*
 Bonnor *257*
 Bonnor, W.B. *332, 334*
 book *801*
 book, information and entropy
 in *154*
 Boone, Roggie *19*
 boost *136, 179*
 boosts *188*
 Bordé, Ch.J. *607*
 Borelli, G. *215*
 boring *446*
 boring physics *426*
 Born, M. *630*
 Born, Max *402, 482, 484, 515*
 boron *835*
 Bose, Satyenra Nath *523*
 Bose-Einstein condensation
 517
 boson *524*
 boson-fermion transmutation
 634
 bosonization *634*
 bosons *523, 635*
 Boss, Alan P. *225*
 bottle *64, 80*
 bottle, full *113*
 bottom quark *829*
 Boughn, S.P. *230*
 boundaries *59*
 boundary conditions *358*
 boundary of space-time *710*
 Bour, L. *401*
 Bourbaki, N. *802*
 Bouwmeester, D. *535*
 Bowden, F.P. *224*
 Bower, B. *225*
 Bowlby, John *476*
 boxes *211*
 Boyce, K.R. *230*
 Bradley *168*
 Bradley, James *77, 167*
 bradyons *194*
 Bragg reflection *396*
 Braginsky, V.B. *223, 330, 331*
 Brahe, Tycho *83*
 Brahm, A. de *803*
 Brahm, D.E. *335*
 Brahmagupta *842*
 braid *534*
 braid symmetry *749, 753, 773*
 brain *42, 413, 434, 563, 625*
 brain size of whales *563*
 brain stem *33*
 brain, clock in *42*
 brains *157*
 Brandt, E.H. *405*
 Brault, J.W. *330*
 Braxmeier, C. *228*
 bread *142*
 breaking *488*
 breathings *806*
 breaths *435*
 Brebner, Douglas *19*
 Brecher, K. *228*
 Brehme, Robert W. *231*
 Bremsstrahlung *395*
 Brendel, J. *516*
 Brennan, Richard *215*
 Brewer, Sydney G. *227*
 Briand, J.P. *585, 607*
 Briatore *235*
 Briatore, L. *330*
 Brightwell, G. *697*
 brilliant *434*
 Brillouin, Louis *403*
 Broglie, Louis de *516*
 bromine *835*
 Bronstein *308*
 Brooks, Mel *151*
 Brower, L.E.J. *45*
 brown dwarfs *124*
 Brown, J.H. *225*
 Brown, Robert *148*
 Brownian motion *150*
 Brownian motors *561*
 browser *859*
 Bruce, Tom *19*
 Brune, M. *603*
 Bryant, D.A. *607*
 bubbles *146*
 Buchanan, Mark *405*
 bucket *28, 306*
 Buckley, Michael *214*
 Buddakian, R. *406*
 Budney, Ryan *19*
 bulge *523*
 Bunn, E.F. *334*
 Bunsen, Robert *509*
 Bunyan, Paul *225*
 Burbridge, E.M. *476*
 Burbridge, G.R. *476*
 Bureau International des Poids
 et Mesures *811*
 Buridan, Jean *85, 222*
 Burke, D.L. *516*
 Burša, Milan *218*
 Busch, Paul *515*
 buses *234*
 bushbabies *82*
 Butikov, E.I. *516*
 Butler, Samuel *414*
 Butoli, André *400*
 button, future *155*
 Buzek, V. *535*
 Bäßler, S. *336*
 Börner, G. *286*

C
 C*-algebra *854*
 C14 dating *407*
 ca. *808*
 Cabibbo angle *622*
 Cabibbo-Kobayashi-Maskawa
 mixing matrix *620*
 cadmium *835*
 caesium *41, 835*
 Cajori, Florian *809*
 calcium *835*
 calculus of variations *118*
 Caldeira, A.O. *602*
 calendar *807, 808*
 californium *835*
 Calzadilla, A. *224*
 camera *50*
 camera obscura *737*
 Cancer *98*
 candela *811*
 Canopus *124, 300*
 Cantor, Georg *430*
 capacitor *381*
 Capella *125*

- Capricornus 98
 capture 99, 316
 carbon 831, 835
 cardinality 431
 cardinals 850
 cardinals, inaccessible 431
 Carducci, Giosuè 914
 Carilli, ... 335
 Carlip, S. 607
 Carlip, Steve 19, 334
 Carmona, Humberto 406
 Carneiro, S. 334
 Carr, Jim 19
 carriage, south-pointing 113
 Carroll, Lewis 477
 Carroll, Lewis, or Charles
 Lutwidge Dogson 155
 Carruthers, P. 516
 cars 165
 Cartan algebra 856
 Cartan metric tensor 855
 Carter 318
 Carter, Brandon 476
 Cartesian 46
 Cartesian product 429
 Casimir effect 396, 580, 645
 Casimir, H.B.G. 606
 Casimir, Hendrik 580
 Caso, C. 828
 Castagnino, M. 336
 cat 64, 384
 categories 715
 category 427, 433
 cathode rays 167, 347
 causal 109
 causal connection 181
 causality 181, 552
 cause 468
 Cavendish, Henry 86
 Caves, C.M. 331, 609
 Cayley algebra 849
 Cayley numbers 849
 Cayley, Arthur 849
 Cd 392
 CdS 391, 396
 Ceasar, Julius 807
 CeB₆ 392
 cell 831
 cell motility 560
 cells 434
 Celsius, Anders 819
 Celtic wobble stone 81
 Cenozoic 288
 centre 854
 centre of gravity 98
 centre of mass 68, 98, 194
 centre, quaternion 846
 centrifugal acceleration 81, 85
 centrifugal effect 322
 centrifugal force 88
 Cerenkov effect 395
 Cerenkov radiation 185
 cerium 836
 CERN 229
 CERN Courier 61
 Cetus 99
 Chahravarty, S. 603
 Chaîneux, J. 810
 Chaitin, Gregory J. 475
 chalkogens 834
 challenge 33, 188
 challenges 16, 18, 20, 27, 27,
 28, 30–32, 34–41, 43–66,
 68–71, 73–75, 77–90,
 92–113, 115, 117–122,
 125–136, 139–143, 146,
 148–163, 165, 167–179,
 181–190, 192–195,
 197–204, 206–211, 216,
 217, 221, 230, 232–250,
 252–281, 284, 285, 289,
 290, 292–296, 298, 300,
 301, 303–310, 313–324,
 326, 327, 334, 338, 339,
 341–343, 345–347,
 349–364, 367–375,
 377–382, 384–391,
 394–398, 401, 413–416,
 419–422, 425–433, 436,
 437, 439, 447, 452,
 455–461, 466, 479–481,
 484–488, 490, 492–494,
 496, 499, 500, 502, 504,
 505, 511–513, 518–524,
 526, 528–534, 539, 540,
 542, 543, 545, 548, 551,
 553–556, 558, 562,
 564–566, 568, 572–574,
 580, 581, 583–587, 590,
 592, 594–601, 611, 629,
 632, 634, 646, 647, 652,
 657, 658, 662, 664, 666,
 673, 678, 685, 688–690,
 694, 700, 701, 703–715,
 717, 719, 721–724, 730,
 739, 740, 745, 755, 756,
 785, 789, 791, 803, 805,
 813, 814, 817–819, 822,
 824, 826, 830, 832, 840,
 842–848, 850–854, 856, 873
 Chan, M.A. 220
 chandelier 86
 Chandler, Seth Carlo 76
 Chang, I. 515
 Chang, J. 841
 Chang, P.Z. 405
 Chang, Yuan-Chung 228, 229
 changes of gauge 128
 changing 33
 channel rays 167
 Chantell, M. 629
 chaos 161, 162, 415
 chapter 802
 charge 136, 408
 charge, amount of 342
 charge, central 856
 chargino 829
 Charlemagne 802
 charm quark 829
 check 128
 cheetah 55
 chemical mass defect 192
 chemistry 164, 830
 chemoluminescence 395
 Cheseaux, ed 293
 chess 36
 Chiao, R.Y. 403
 Chiao, Raymond 403
 child psychology 413
 childhood 39, 44
 Childs, J.J. 606
 Chimborazo, Mount 88
 Chinnapared, R. 335
 chlorine 836
 chocolate 293
 chocolate bar 140
 choice 462
 Chomsky 216
 Chomsky, Noam 447
 Choquet-Bruhat, Yvonne 274

- Christ, N.H. 697
 christianity 799
 Christodoulou, D. 335
 Christoffel symbols of the
 second kind 276
 chromatic aberrations 371
 chromium 836
 Chu, S. 402, 403, 607
 Chubykalo, A.E. 96, 223
 Chudnovsky, David V. 826
 Chudnovsky, Gregory V. 826
 Chung, K.Y. 607
 Ciafaloni, M. 697
 Cicero 469
 circular 90
 circularly polarized waves 364
 Ciufolini 253
 Ciufolini, Ignazio 250, 331
 CKM matrix 621
 Clancy, E.P. 329
 Clarke 216
 class 429, 435
 classical 101, 856
 classical apparatus 554
 classical mechanics 102
 classical physics 102, 408
 classification 417
 classification of concepts 842
 classifiers 418
 Clauser, J.F. 604
 Clausius 305
 Clausius, Rudolph 149, 151,
 304, 591
 claustrophobics 290
 Clerk Maxwell, James 179,
 659
 click beetles 82
 clock 41, 65, 86
 clock in brain 42
 clock paradox 183
 clock puzzles 50, 214
 clock, air pressure powered 65
 clock, exchange of hands 50
 clocks 41, 43, 111, 309, 565
 clocks and Planck time 675
 clocks, do not exist 565
 clockwise rotation 43
 clone 525
 clone, biological 526
 Close, Frank 618
 closed system 153, 155
 cloud 316, 737
 Clouds 281
 clouds 840
 Clunio 90
 CMOS 388
 Co 392
 coal 394
 cobalt 836
 CODATA 825, 828
 Codling, K. 825
 Coehoorn, Reinder 406
 coffee machines 152
 Cohen, M.H. 230
 Cohen, Paul J. 474
 Cohen, Philip 404
 Cohen, Reuben Hersch, Paul J.
 429
 Cohen-Tannoudji, C. 514
 coherence 538, 547
 coherence length 497
 coherence time 497
 coherent 545, 577
 cold fusion 446
 Colella, R. 607
 Coleman, S. 630
 Colladon, Daniel 140
 collapse 322, 549, 552
 collapse, wavefunction 545
 Collins, D. 535
 Collins, J.J. 215
 collision 193
 collisions 104
 Collège de France 164
 colour 394, 492, 614, 829
 colour displacement, Wien's
 398
 colour, world survey 403
 coloured constellation 300
 colours 658, 693
 Columbus 307
 comet 91, 99, 370
 comet shower 410
 comet, Halley's 91
 comets 402
 Comins, Neil F. 223
 Commission Internationale des
 Poids et Mesures 811
 communication, faster than
 light 375
 communism 348
 commutative 433, 854
 commutator 854, 855, 855
 compact disk 435
 comparison with a standard
 449
 complete 35, 54, 128, 828
 completeness 38, 42, 45, 63,
 344
 complex conjugate 843
 complex numbers 437, 854
 complexity 154
 complexity, 'infinite' 463
 composed 522
 composite 771
 compositeness 511
 Compton (wave)length 512
 Compton effect 395
 Compton satellite 595
 Compton wavelength 645
 Compton, A.H. 515, 757
 Compton, Arthur 492
 computational high energy
 physics 859
 computer programs 715
 computer science 859
 computer scientists 413
 computers 21, 157
 concatenation 129
 concatenations 188
 concept 423, 427
 concepts 165
 concepts, classification of 842
 condensed matter physics 859
 condom problem 518
 condoms 526
 conductance 585
 conductivity 391
 configuration 34
 configuration space 52, 53, 529
 conformal group 202, 202
 conformal invariance 203, 377
 conformal transformations 202
 Conférence Générale des Poids
 et Mesures 811
 conical sections 260
 conjectures 443
 conjugate quaternion 845
 Conkling, J.A. 52
 connected bodies 57

- Conroy, R.S. 402
 consciousness 469, 555
 conservation 63, 139, 344, 462
 conservation of momentum 64
 conservative 105
 conservative systems 119
 conserved quantities 27
 constancy of the speed of light 203
 constellation 98
 constellations 56, 280
 constraints 119
 contact 102
 container 44, 180
 containers 47
 continents 76
 continuity 38, 42, 45, 63, 133, 344
 continuous 44, 54
 continuum approximation 57
 continuum hypothesis 431
 continuum mechanics 113
 contraction 269, 279
 contradictions 669
 convection 154
 Convention du Mètre 811
 Conway, J.H. 475
 Conway, John 435
 Conway, John H. 475
 cooking 164
 Cooper, Heather 222
 Cooper, J.N. 214
 cooperative structures 161
 coordinates 46
 coordinates, fermionic 749
 coordinates, Grassmann 749
 Copernicus 220
 Copernicus, Nicolaus 169, 476
 copper 342, 391, 836
 Copperfield, David 390, 406
 copy machines 525
 copy, perfect 525
 Corballis, M.C. 401
 Cordero, N.A. 331
 Coriolis acceleration 73, 220
 Coriolis effect 220
 Coriolis, Gustave-Gaspard 66, 73
 cork 64, 80
 cornea 364, 394
 Cornell, E.A. 216
 corner figures 33
 corner patterns 33
 Corovic, Dejan 19
 corpuscule 56
 correct 443
 Correspondence principle 273
 cortex 33
 Cosman, E.C. 401
 cosmic background radiation 334
 cosmic censorship 324, 336
 cosmic evolution 29
 cosmic mirror 861
 cosmic radiation 378
 cosmic rays 91, 195, 378, 382, 410, 596
 cosmological constant 269, 273, 295, 653, 727
 cosmological constant paradox 690
 cosmological principle 284
 cosmonauts 368
 cosmos 35, 415
 Costa, G.E.A. Matsas, S.S. 230
 Costa-Krämer, N. Garcia, P. Garcia-Molchales, P.A. Serena, J.L. 605
 Costabel, Pierre 142
 Costella, J.P. 230
 Costella, John P. 516
 Cotton-Mouton effect 393
 Couch, E. 335
 Couder, Y. 475
 coulomb 344, 812
 Coulomb explosions 589
 Coulomb gauge 545
 Coulomb, Charles-Augustin de 345
 countability 430
 covalent radius 840
 covariant 461
 cows 624
 Cox, A.N. 332
 crackle 218
 crackpots 175, 228, 312, 313, 427, 454, 721, 862
 Crane, H. Richard 220
 Craven, J.D. 223
 creation 27, 298, 510, 688, 715
 creation is a type of motion 462
 creation is impossible 711
 creation of light 575
 creation of motion 64
 creation operator 524, 633
 creation science 446
 Crespi, Roberto 18
 Crewther, R.J. 629
 critical magnetic field 340
 critical mass density 289
 Crookes, William 369
 cross product 68, 850
 Crowe, Michael J. 220
 Crystal, David 424
 Cs 394
 Cu 392
 cumulonimbus 381
 cuprum 836
 Curie, Marie 836
 Curie, Pierre 836
 curiosities 36
 curiosity 28, 110
 curium 836
 curl 355
 current masses 621
 curvature 50, 263
 curvature, gaussian 263
 curvimeter 47
 cyclotron resonance 393
 Cygnus X-1 323
 cyrillic alphabet 806
- D**
- d'Inverno, Ray 329
 daemons 647
 Daffertshofer, A. 535
 daisy 434
 Dale Stewart, T. 400
 Dalibard, J. 603
 Dalton, K. 332
 Dalí, Salvador 563
 Dam, Van 702
 Damour 595
 Damour, T. 608
 Damour, Thibault 326, 336
 damping 105, 541
 Dante Alighieri 83
 dark matter 192
 dark matter problem 296
 dark stars 124

- dark, speed of the 185
darkness 186
Darley, Vincent 19
Darwin 446, 455, 605
Darwin, Charles 473
Das, A. 697
David Pritchard 513
Davidson, C. 329
Davies, Paul 592, 607
Davis, Chandler 472
Davson, H. 475
Davy, Humphry 348
day, length of 94
day, time unit 813
de Gasse Tyson, Neil 223
De Gennes, P.-G. 757
de Groot, D.G. 407
de Jong, Marc 18
De La Garanderie, A. 605
de Sitter 262
de Vega, H.J. 695
de Witt, B.S. 695
dead alone are legal 398
death 26, 65, 67, 111, 135, 142,
169, 488, 544, 629, 789, 795
death sentence 142
Deaver, B.S. 820
decades 819
decay 157
decay of photons 308
deceleration parameter 291
decoherence 539, 547
decoherence time 540, 541
deer 33
deformation 58
Degen, Carl friedrich 849
degree Celsius 812
degree, angle unit 813
Dehmelt, H. 405, 841
Dehmelt, Hans 225, 405, 516,
698, 840, 841
Dehn, Max 49
deity 455
Dekker, J.P. 407
Deleuze, Gilles 798
Della Scala, S. 475
delta function 376
demarcation 466
Demko, T.M. 220
Democritus 144, 446, 455,
458, 476, 725, 745, 799
demon 421
demon, Maxwell's 421
Denardo, B. 606
density functional 538
density matrix 538
density perturbations 287
density, proper 271
dependence on $1/r^2$ 326
DeRaad, L.L. 400
derivative 54
derivative at a point 54
Desari, R.R. 606
Descartes, R. 802
Descartes, René 46, 415, 476,
796
description 51, 464
descriptions, accuracy of 165
Deser 272
Deshpande, V.K. 230
design 463
Desloge, Edward A. 220, 231
Desmet, S. 400
Desoxyribonucleic acid 573
Desoxyribonukleinsäure 573
details 417, 446
detector 550
detectors of motion 479
DeTemple, D.W. 826
determined 111
determinism 109, 110, 163,
555, 689
Detweiler, S. 335
Deubner, Franz Ludwig 624
devil 513
devils 647
Devon 94
DeWitt-Morette, Cecile 274
de las Nieves, F.J. 222
de la Mettrie, J. Offrey 163
de Picciotto, R. 605
de Pádua, S. 515
Dholakia, K. 402
diamagnetism 392
diameter 710
diamond 391, 394
diamonds 126, 628
Diana, princess 445
dichroism 392, 394
Dicke, R.H. 223, 330, 516
Dieks, D. 535
Dieks, Dennis 525
dielectricity 393
Dietrich, F. 405
diffeomorphism invariance 311
differences are approximate
745
different 500
differential 54
diffraction 277, 368, 501, 502
diffraction limit 368
diffraction pattern 548
diffusion 157
Diffusion 158
DiFilippo, F. 230
DiFilippo, Frank 19
digamma 804
dilations 135, 202
Dillard-Bleick, Margaret 274
dimension 854
dimension, fourth 181
dimensionality 38, 45
dimensionality, spatial 377
dimensionless 821
dimensions 45
dimensions, three spatial 530
Diner, S. 695, 720, 730, 756
dinosaurs 288
Diophantos of Alexandria 843
dipole strength 378
Dirac 450, 466, 500, 528, 591
Dirac's large number
hypothesis 755
Dirac, P.A.M. 515, 575, 606,
609
Dirac, Paul 139, 509, 606
direction 38
disappearance of motion 64
disasters, future 410
discovery of physical concepts
441
discrete 129
dispersion relation 255, 361
dispersion, anomalous 403
dissipative 105
dissipative systems 106, 118,
161
distance 47
distance, rod 205

- distinguish 33
distinguishability 38, 42, 45, 63, 344
distribution, Gaussian normal 149
Dittus, H. 336
Diu, B. 514
divergence 87
DiVicenzo, D.P. 603
divine surprises 468
division 434
division algebra 846, 854
Dixon, Bernard 218, 666
DNA 46, 366, 420, 423, 435, 559, 573, 819
DNA (human) 124
doctrine 444
Dogarin, A. 403
Dolittle 119
dolphins 661
Dolto, Françoise 605
domain of definition 432
door sensors 173
Doplicher, S. 697
Doppler effect 172, 173
Doppler red shift 300
Doppler, Christian 172
Dorda, G. 606
Doroshkevich 285
Doroshkevich, A.G. 333
Dorsey, A.T. 603
Douady, S. 475
double cover 846
doublets 132
Dougherty, R. 218
Douglas, R. 474
Dove prisms 219
down quark 829
Doyle, Arthur Conan 141
drag 105
drag coefficient 105
Dragon, N. 330
Dragon, Norbert 19
dreams 415, 796
Dresden, Max 476
dressed singularities 323
drop 106
drosophila 661
Droste, J. 240, 330
Drumond, P.D. 609
Drury, L.O'C. 607
dual field tensor 354
duality in string theory 720
duality, electromagnetic 360, 640
dubnium 836
Dugay 169
Dugay, M.A. 227
Duhem, Pierre 475
Dumont, J.P. 214
Dumont, Jean-Paul 332
Duran, E. 535
Duration 40
Durieux, M. 226
Dusenberg, David 667
Dusenbery, David 219
dust 271, 395
Dutton, Z. 216
Dutton, Zachary 216
duvet 154
dwarfs 124
Dwayne Hamilton, J. 231
dyadic numbers 436
dyadic rational numbers 435
dyadosphere 596
dynamic friction 105
dynamics 102
dynamos 350
dyons 633
Dyson, F.W. 329
Dyson, Freeman 314
dysprosium 836
Dziedzic, J.M. 402
- E**
e-mail 859
E. coli 662
E. Schaefer, Bradley 228
E. Schröder, Ulrich 231, 329
e.g. 808
ear 45, 46, 143, 562
Earnshaw's theorem 389
earth 72, 154
earth core solidifies 410
earth formation 287
earth from space 861
earth rotation and superfluidity 585
earth rotation slowing 410
earth stops rotating 88
earth's axis 77
earth's rotation 818
earth, length contraction 183
earth, mass of 86
earth, shape of 88
earth-alkali metals 834
earthquakes 221
Ebbinghaus, H.-D. 842, 857
eccentricity 261
eccentricity of earth's axis 78
Eccles, John 476
Eckstein, G. 229
ecliptic 89
eddies 661
Eddington 746
Eddington, A.S. 329
Eddington, Arthur 460, 476, 725, 730, 758
Edge, Ron 406
Edwards, R. 400
effect 468
effect, butterfly 162
effect, sleepinf beauty 376
effort 103
EHF 365
Ehlers, J. 334
eigenvalue 551, 853
eigenvalues 131, 549
eigenvector 853
eigenvectors 853
eight-squares theorem 849
Eigler, D.M. 404
Einstein 150, 192, 234, 249, 288, 311, 328, 450, 605
Einstein algebra 311
Einstein tensor 269
Einstein, 1951, Albert 499
Einstein, A. 332, 334
Einstein, Albert 27, 93–95, 120, 133, 135, 139, 148, 170, 171, 179, 188, 189, 228, 232, 238, 245, 272, 311, 326, 328, 367, 376, 419, 438, 472, 488, 489, 497, 523, 575, 603, 669, 836
Einstein, Eduard 238
einsteinium 836
Ekman, Walfrid 220
elasticity 104, 241
elders 859

- Electr. conductivity 646
 electrets 339
 electric charge 341
 electric effects 104
 electric field 339, 344
 electric polarizability 380
 electric potential 355
 electrical conductance 585
 electrical resistance 379
 electricity 346
 electrification 391, 589
 electrochromicity 395
 electrodynamics 844
 electrokinetic effect 394
 electroluminescence 395
 electrolytic activity 394
 electromagnetic coupling
 constant 693
 electromagnetic field 339, 350,
 356
 electromagnetic field, linearity
 361
 electromagnetic smog 380
 electromagnetic unit system
 345, 816
 electromagnetism 87, 102
 electron 167, 828
 Electron gyromagnetic ratio
 646
 electron radius 532, 725, 829
 Electron speed in metals 39
 electron Volt 816
 electrooptical activity 394
 electroosmosis 394
 electrostatic unit system 345,
 816
 electrowetting 394
 element of set 38
 element, of set 428
 elementary particle 526, 647
 elementary particles 683
 elementary particles, size of
 211
 elements 833, 834
 elephants 159, 422
 Eliza 423
 ellipse 85
 ellipses 261
 Ellis 311
 Ellis, G.F.R. 329, 333, 720
 Ellis, J. 698, 720
 Ellis, T. Rothmann, G.F.R. 334
 elongation 750
 Elswijk, H.B. 226, 400
 Elswijk, Herman 18
 Elswijk, Herman B. 226
 elves 382
 ELW 365
 embryo 560
 Emde Boas, P. Van 534
 emergence 163, 455
 emergence of properties 455
 emergent properties 163
 Emerson, Ralph Waldo 426
 Emery, V.J. 630
 emissivity 394, 397
 emotion change 29
 Empedocles 167
 empirical 444
 empty space 87
 Emsley, John 156
 encyclopédie 348
 end of physics 410
 end of science 459
 Enders, A. 403
 energy 66, 104, 125, 133, 191,
 341
 energy conservation 67, 136,
 385
 energy flux 817
 energy of the universe 304, 591
 energy velocity 374
 energy width 830
 energy, free 192
 energy, undiscovered 192
 energy-momentum 4-vector
 198
 energy-momentum tensor 270,
 358
 Engels, Friedrich 108
 Engl, Walter L. 357
 English language 424
 English language, size of 434
 enlightenment 37
 Enquist, B.J. 225
 ensemble 519
 ensembles 716
 entertainment industry 18
 entities 417
 entropic forces 584
 entropy 151, 304, 419
 entropy of a black hole 692
 entropy of black hole 320
 entropy, state of highest 159,
 597
 environment 33, 399, 408, 409,
 414, 539
 enzymes 836
 ephemeris time 40
 Epicure 492
 Epicurus 470, 490
 Epikuros 470
 eponyms 809
 EPR 546, 808
 EPR experiments 525
 Epstein, R.P. 477
 equilibrium 539
 equipotential lines 354
 Equivalence principle 273
 equivalence principle 326
 erasable 422
 erasing information 157
 Erasmian 804
 erbium 836
 Erdős, Paul 49, 842
 ergosphere 319, 319
 Erlykin, A.D. 404
 Erschow, A. 535
 Ertmer, W. 405
 escape velocity 314
 Escher, M.C. 671
 Escherichia coli 58
 essence of universe 717
 Eta Carinae 410
 Etchemendy, J. 475
 eth 803, 810
 ethics 111
 Etienne, B. 605
 Ettinghausen effect 393
 Ettinghausen-Nernst effect 393
 Euclid 38
 Euclid: 680
 Euclidean 38, 55
 Euclidean space 45
 Euclidean vector space 38, 852
 Eukleides 38
 Euler, ... 516
 Euler, L. 802
 Euler, Leonhard 76, 101, 102,
 264, 845

- europium 836
 EUV 367
 Evans, J. 223
 evaporation 157, 597
 event 40, 440
 event horizon 208
 Event symmetry 689
 event symmetry 747
 events 179, 797
 Everest, Mount 88
 Everitt, C.W. 820
 Everitt, F. 336
 everlasting life 65
 eversion 663
 evolution 34, 422, 567
 evolution equation 108
 evolution equations 408
 evolution, marginal 290
 evolutionary biologists 413
 ex nihilo 462
 excess radius 264
 exclamation mark 802
 exclusion principle 121
 existence of mathematical concepts 456
 existence of the universe 461
 existence, physical 455
 expansion of the universe 79
 expansions 135
 experience 417, 417
 Experience Island 26, 30
 experimental high energy physics 859
 experimental nuclear physics 859
 experimental physicists 442
 experimentalists 442
 experiments 440
 explanation 467, 555
 explosion 297
 explosion of volcano 410
 extension 145
 extensive quantities 64, 151
 Exton, A. 335
 extrasolar planets 124, 301
 extremal identity 719
 extremum 118
 extrinsic curvature 262
 eye 33, 386, 562
 eye, human 364, 401
 eyelid 50
 eyes 33
 Eötvös, R. von 223, 330
 Eötvös, Roland von 74, 223, 248, 330
- F**
 Facchi, Paolo 605
 fact 440
 facts 443
 Fairbank, W.M. 400
 Fairbanks, J.D. 820
 faithful 131
 Falco, E.E. 334
 Falk, G. 223, 329
 fall 85, 248
 fall of moon 85
 fall, permanent 315
 Faller, James E. 402
 false 443
 familiarity 33
 fan-out effect 694
 Fang Lizhi 472
 farad 812
 Faraday 378
 Faraday cages 379
 Faraday effect 392
 Faraday rotation 392
 Faraday, Michael 348, 350, 378
 Farley, F.J.M. 228
 Farrant, Penelope 219
 Fasching, G. 280
 faster than light motion, in collisions 194
 Fastest bird 39
 fate 708
 Faust 717
 Fayeulle, Serge 224
 Fe 392, 396
 Feelings 446
 feet 146
 Fehr, C. 224
 Fekete, E. 223, 330
 feldspat 363, 394, 395
 fence 178
 fencing 532
 Ferreira, X. 334
 Fermi, Antonio 19
 Fermi, E. 604
 Fermi, Enrico 523, 836
 fermion 524
 fermionic coordinates 749, 851
 fermions 523, 635
 fermium 836
 Fernandez-Nieves, A. 222
 ferroelectricity 393
 ferromagnetism 392
 ferrum 837
 Few, Arthur 382
 Feyeraabend, Paul 447, 459
 Feynman 448, 578
 Feynman, R.P. 331, 695
 Feynman, Richard 555, 578, 579
 Feynman, Richard ('Dick') Phillips 501
 Feynman, Richard P. 214
 field emission 393
 field evaporation 394
 field ionisation 394
 field lines 354
 field theory 354
 Field, M.S. 606
 field, mathematical 433
 field, physical 339
 Figueroa, D. 224
 figures in corners 33
 filament 147
 fine structure constant 361, 374, 513, 693, 815, 821
 fine tuning 657
 fingers 362
 finite 430, 459
 finite number 452
 Fink, Hans-Werner 226, 584, 607
 Finkelstein 682
 Finkelstein, D. 404, 697
 Finkenzeller, Klaus 19
 fire 21, 391
 Firestone, R.B. 535, 841
 Firpić, D.K. 222
 first property of quantum measurements 548
 Fischbach, E. 515
 Fischer, M.C. 605
 Fisher, M.P.A. 603
 Fitzgerald, George F. 179
 Fizeau, Hippolyte L. 169

- Flachsel, Erwein 214
 flagella 58
 flagellar motor 67
 flame 36, 81, 157, 391
 Flato, M. 857
 Flavell, J.H. 417
 flavour 622
 fleas 82
 flies 33
 Fließbach, Torsten 329
 flight simulators 846
 Flint, H.T. 697
 flip movie 33
 flip movie, explanation of 51, 52
 floor 21
 flow 151
 flow of momentum 102
 flow of time 43, 312
 flowing 346
 Floyd, R.M. 335
 fluctuations 539
 fluid mechanics 113
 fluorescence 395
 fluorine 836
 fly 87
 fold 798
 Foldy, L.L. 516
 fondation Clay 164
 Fonseca, E.J.S. 515
 fool 517
 Foong, S.K. 608
 force 62, 68, 276
 force, central 62
 force, use of 102
 Foreman, M. 218
 forerunner velocity 375
 forest 33
 forgery 420
 forgetting 422
 form, mathematical 357
 formal sciences 439
 Formula One 37
 formulas 809
 Forssman, Friedrich 605
 Fortson, E.N. 699
 Foster, James 224, 328
 Foucault 250
 Foucault pendulum 585
 Foucault, Jean Bernard Léon 74
 four-squares theorem 845
 fourth dimension 179, 181
 Fowler, E.C. 228
 Fowler, L.A. 332
 Fowler, W.A. 476
 Fowler, Willy 467
 fractal 47, 54, 140
 fractals 47
 fractional quantum Hall effect 534
 fractional quantum hall effect 574
 Fraenkel, Adolf/Abraham 428
 frame dragging 259
 frame of reference 205
 frame-dragging 250
 frames of reference 126
 Francis, G. 667
 francium 831, 836
 Frank, Louis A. 223
 Franklin, Benjamin 141, 342
 Fraser, Alistair B. 401
 Frasinski, L.J. 825
 Fraunhofer 363
 Fraunhofer lines 235, 509
 Fraunhofer, Joseph 509
 Fredenhagen, K. 697
 free fall, permanent 315
 free will 110
 Freederichsz effect 394
 Freimund, D.L. 517
 French, A.P. 231, 404
 French, Robert M. 218
 frequency mixing 396
 Fresnel 363
 Fresnel, Augustin 368
 friction 65, 105, 105, 152, 155, 541
 friction produced by tides 94
 friction, importance of 105, 152
 Friedberg, T.D. Lee, R. 697
 Friedman, J.L. 695
 Friedman, J.R. 604
 Friedman, R.A. 282
 Friedmann, A. 333
 Friedmann, Aleksander Aleksandrowitsch 289
 Frieze, M.E.J. 402
 Frisch, D.H. 229
 Froggatt, C.D. 629
 front velocity 375
 ftp 859
 fuel consumption 165
 Full, R. 605
 Fumagalli, Giuseppe 219, 476, 514
 function 431
 function, mathematical 431
 fundamental interaction 102
 Futhark 803
 futhark 806
 future and present 465
 future button 155
 future light cone 180
 future, remembering 155
 Fürstenau, H. 698, 757
G
 γ -rays 167, 367
 G-parity 829
 GaAs 395
 Gabrielse, G. 841
 Gabuzda, D.C. 230
 Gadelka, A.L. 720
 Gadolin, ... 836
 gadolinium 393, 836
 Gaia 162
 gait 71
 galaxy 307
 Galaxy formation 287
 galaxy group 123
 galaxy supercluster 123
 Galilean physics 37, 102
 Galilean space 45
 Galilean time 42
 Galilean velocity 38
 Galilei, Galileo 37, 43, 51, 472
 Galileo 51, 72, 79, 86, 96, 97, 141, 142, 144, 167, 458, 481, 482
 Galileo Galilei 462
 Galle, Johann Gottfried 569
 gallium 836
 gallium arsenide 391

- galvanometer 104
 gamma ray burst 410, 595, 608
 gamma ray bursts 170, 228, 282, 302, 336, 596, 608, 691
 Gamow, G. 332
 Gamow, George 285
 Gans, R. 406
 Garay, L. 696
 Garay, L.J. 698
 Garcia-Ruiz, J.M. 475
 Gardner, Martin 476, 534
 Garg, A. 603
 Garlaschelli, L. 475
 Garret ed., Don 756
 Garrett, A. 219
 gas 150
 gas planets 124
 gases 395, 519
 Gaspard, Pierre 150, 226
 gauge symmetries 135
 gauge theory 44
 gauge transformation 356
 gauge transformations 408
 gauge, Coulomb 545
 Gauss 850
 Gauss, Friedrich 264
 Gaussian distribution 149
 gaussian integers 850
 gaussian primes 850
 gaussian unit system 345, 816
 Gd 392
 GdSiGe 393
 Ge, M.-L. 695
 Gehrels, N. 335, 696
 Geim, A.K. 405, 406
 Geim, Andre 405
 Gelb, M. 215
 Gell-man matrices 614
 Gell-Mann, Murray 537
 Gemini 98
 general lie 446
 General Motors 341
 general physics 859
 general relativity 171, 232
 general relativity and quantum cosmology 859
 general relativity in one paragraph 266
 general relativity in ten points 324
 general relativity, accuracy of 325
 general relativity, first half 241
 general relativity, second half 245
 generalized coordinates 120
 generators 135, 844, 855
 genes 559, 560
 genius 497
 geniuses 443
 Gennes, P.G. de 607
 genuine 447
 geocentric system 100
 geodesic deviation 279
 geodesic effect 261, 326
 geodesic, lightlike 243
 geodesic, timelike 243
 geodesics 108
 geodynamo 387
 geoid 88
 geometrodynamical clock 310
 Georgi, Renate 18, 477
 geostationary satellites 92
 Gerlach 508
 Gerlach, W. 516
 Gerlbaum, B.R. 218
 germanium 836
 Germany 398
 Geroch, R. 335
 Geroch, Robert 311
 Ghahramani, Z. 224
 Ghavimi-Alagha, B. 222
 Ghirardi, G.C. 607
 ghost 36
 ghosts 534, 647
 giants 142
 Gibbs' paradox 519
 Gibbs, Josiah Willard 519
 Gibbs, P. 696
 Gibbs, Phil 402, 689
 Giessibl, F. 605
 Gilbert, William 339
 Gilligan, James 108
 Giltner, D.M. 228
 Gisin, N. 516
 Giulini, D. 333
 Glasheen, Jim W. 221
 glass 391, 392, 394
 Glassey, Olivier 19
 Glattli, D.C. 605
 Glatzmaier, G.A. 405
 Glauber 502
 globally 112
 glory 402
 glossary 874
 glow of eyes of a cat 384
 glueball 831
 gluino 829
 gluon 828
 Gmelin 841
 gnomonics 41
 goblin 836, 837
 god 717, 798, 839
 goddess 836, 838, 840
 goddesses 647
 gods 83, 92, 214, 304, 430, 445, 455, 463, 472, 554, 647, 787
 Goenner 256
 Goenner, Hubert 329
 Goethe, Johann Wolfgang von 442, 456, 717
 gold 21, 394, 836
 Goldhaber, A.S. 400
 Goldman, V.J. 605
 Goldsmith, D. 404
 Goldstein, E. Bruce 216
 Goles, E. 227
 Golubitsky, M. 215
 Gonshor, H. 475
 Good, R.H. 231
 Gordon, A. 404
 Gossard, A.C. 606
 Goss Levi, Barbara 604
 Gothic alphabet 806
 Gothic letters 806
 Gottfried, Kurt 603
 Gould, Andrew 259
 Gould, R. 757
 Gould, Stephen J. 473
 Gour, G. 606
 GPS 247
 grace 30, 71, 215
 Gracovetsky, Serge 71, 220
 gradient 87
 Graham, Geoff 604
 grammatical 425
 grampus 455, 464
 grand unification 627
 Grandjean, F. 400

- Grant, E. 403
 graphics, three-dimensional 846
 graphite 391, 394
 grass 21, 178
 Grassmann coordinates 749
 Grassmann numbers 851
 Grassmann, Hermann Günther 851
 grating 502
 Graves, John 849
 gravitation 83, 102, 104
 gravitation and measurements 165
 gravitational acceleration, standard 55
 gravitational Bohr radius 599
 gravitational Doppler effect 234
 gravitational energy 271, 277
 gravitational field 88
 gravitational lenses 323
 gravitational lensing 301
 gravitational mass 95
 gravitational radiation 329
 gravitational red shift 234, 300
 gravitodynamics 254
 gravitoelectric field 252
 gravitoluminescence 395
 gravitomagnetic (vector) potential 252
 gravitomagnetic field 252
 gravitomagnetism 326
 graviton 528, 601
 gravity 233
 gravity Faraday cages 380
 gravity inside matter shells 99
 Gravity Probe B 250
 gravity wave detectors and quantum gravity 691
 gravity wave emission delay 326
 gravity waves 371
 gravity, centre of 98
 gravity, essence of 100
 gravity, sideways action of 86
 gray 812
 Great Wall 368
 Grebe 235
 Greek number system 807
 green 366, 386
 green flash 372
 green ideas 447
 green ray 402
 green star 398
 Green, M.B. 695
 Greenberg, O.W. 534, 535
 Greenberger, D.M. 535
 Greenbergest, T.V. 535
 greenhouse effect 155
 Greenland, P.T. 841
 Greenler, R. 402
 Greenstein, J.L. 330
 gregorian calendar 808
 Gregory, R. 698
 Greiner, J. 336, 608
 Greiner, Jochen 19, 595
 Griessen, R. 407
 Griffith, W.C. 699
 Griffiths, D.J. 405
 Grimes, Barbara 424
 Grinder, John 111, 214
 Grinstein, G. 603
 Gross, B. 401, 841
 Gross, D.J. 697
 Gross, R.S. 221
 group velocity 373
 group velocity can be infinite 374
 group, conformal 203
 group, mathematical 129
 growth 29, 159
 growth processes 114
 Gruber, R.P. 335
 Grünbaum, Branko 129
 Grünberg, H.-H. von 607
 Gschneidner, Karl A. 406
 Guglielmini, Giovanni Battista 72
 Guiragossian, Z.G.J. 228
 gulf stream 220
 Gulliver's travels 481
 Gunzig, E. 695, 720, 730, 756
 GUT epoch 287
 Guth, Alan 304
 Gutierrez, G. 224
 Gutzwiller, Martin C. 90
 Guy, R.K. 475
 gymnasts 70
 gyromagnetic ratio 322, 511
 gyroscope 74
 Gödel's theorem 715
 Gödel, Kurt 447
 Gál, József 401
- ## H
- H. Zurek, Wojciech 603
 Haas, A.E. 481
 Haber, John 19
 Hadamard, Jacques 477
 Hadley, Mark 336
 hadrons 287
 Haeckel, Ernst 441
 Hafele 235
 Hafele, J.C. 229, 330
 hafnium 836
 Hagedorn temperature 642
 Hagen, Eduard 74
 hair 21
 Hair growth 39
 hairs 435
 Hajnal, A. 534
 Hakonen, Pertti J. 825
 Hales, Tom 584
 Haley, Stephen 19, 390
 Haley, Stephen B. 406
 half-life 830
 Hall effect 392
 Halley, Edmund 91
 Halliwell, J.J. 218
 halo 368, 383, 402
 halogens 834
 Hamilton 845
 Hamilton's principle 115
 Hamilton, W. 802
 Hamilton, William 428
 Hamilton, William Rowan 844
 Han, L.V. 216
 Hanbury-Brown, R. 496, 515
 hand 194, 845
 hand in vacuum 329
 handedness 359
 hands of clock 50
 Hanle effect 393
 Hannout, M. 516
 Hardcastle, Martin 19
 Hardin, C.L. 403
 Hardy 443
 Hardy, G.H. 89
 Harlen, V. 473

- harmonic functions 389
 harmonic motion 139
 Haroche, S. 603
 Haroche, Serge 544
 Harrington, R.F. 401
 Harriot, T. 802
 Harris, S.E. 216
 Hartle, J.B. 757
 Hartman, W.K. 222
 Hartmann, D. 336, 608
 Hartung, R.W. 535
 hassium 836
 Hatcher, W.S. 474
 Haubrich, D. 405
 Hausch, T.W. 401, 841
 Hausdorff, Felix 47
 Hausherr, Tilman 19, 406
 Hawking 311
 Hawking, S. 333, 720
 Hawking, S.W. 696, 757
 Hawking, Stephen 320, 323, 593
 Hawking, Stephen W. 333
 Hawking, Steven 298
 Hayes, Allan 19
 Hays, J.D. 221
 He-Ne 395
 heart beats 435
 heartbeat 86
 heat 151
 Heat capacity of metals 646
 heat radiation 391
 heat & pressure 104
 Heath, T. 697
 Heath, Thomas 220
 Heaviside 251, 352, 848
 Heaviside formula 357
 Heaviside-Lorentz unit system 345, 816
 heavy metals 834
 Heckenberg, N.R. 402
 Heflinger, L.O. 405, 406
 Hegerfeldt, G. 604
 height 318
 Heiligenschein 383
 Heisenberg 381, 450
 Heisenberg picture 537, 546
 Heisenberg, W. 516, 609, 696
 Heisenberg, Werner 164, 482, 484
 helicity 527
 helicopter 378
 heliocentric system 99
 helioseismologists 624
 helium 123, 147, 167, 210, 287, 296, 390, 394, 467, 511, 544, 585, 604, 655, 656, 831, 836
 Hellinger, Bert 224, 443, 471, 604, 796
 Hellund, E.J. 697
 Hellwege, K.-H. 476
 Helmholtz 67, 363
 Helmholtz, Hermann von 385, 470
 Helmont, Johan Baptista von 150
 Henbest, Nigel 222
 Henry 812
 Heracles 281
 Heraclitus 27
 Heraclitus of Ephesos 34, 127, 286
 Hermann von Helmholtz 148
 Hermes Trismegistos 792, 798
 Hermes, H. 857
 hermitean 131
 hermitean vector space 852
 Herrmann, F. 226
 Hersch, Reuben 474
 Herschel, J. 293
 Herschel, William 363
 Hertz 352
 hertz 812
 Hertz 848
 Hertz, H.G. 219
 Hertz, Heinrich 119
 Hertz, Heinrich Rudolf 107, 362
 Hertz, J. 418
 Hertzlinger, Joseph 19
 Hertzprung-Russel diagram 286
 Hesiod 284
 Hestenes, D. 224
 Hewitt, Leslie A. 214
 Hewitt, Paul G. 214
 Hewitt, Susan 659
 Heyningen, Frank van 18
 Hg 393
 hidden variables 552
 Higgs 829
 higgsino 829
 high 126
 Hilbert space 852
 Hilbert's problems 716
 Hilbert's sixth problem 716
 Hilbert, David 120, 135, 268, 272, 438, 716, 755
 Hilgevoord, Jan 515
 Hill, E.L. 697
 Hiller, R.A. 406
 Hillery, M. 535
 Hillman, Chris 19
 Hilversum 383
 Hipparchos 75, 168
 hips 71
 Hirano, M. 224
 Hirzebruch, F. 857
 hit with a field 357
 Hitachi 517
 Hodges, L. 223
 hodograph 53, 84, 97
 Hoffman, Donald D. 34, 474
 Hohenstatt, M. 225, 405
 hole argument 311
 hole paradox 311
 hollow earth hypothesis 312
 hollow earth theory 50
 Hollywood 119, 219
 Hollywood movie 201
 Hollywood movies 140, 440, 708
 holmium 836
 hologram 387
 holography 714
 holonomic 119
 holonomic-rheonomic 119
 holonomic-scleronomic 119
 Holstein, B.R. 332
 Holt, R.A. 604
 Homo sapiens appears 288
 Homo sapiens sapiens 288
 homogeneity 42, 45
 homogeneous 845
 homomorphic 131
 homomorphism 131
 Hones, Bill 406
 honey bee 63
 honey bees 363

- Hoofit, 't 592
 Hoofit, G. 't 697
 Hoofit, G.W. 't 401
 Hoofit, G. 't 720
 Hooke 89
 Hooke, Robert 84
 Hopi 218
 Horace 107, 232
 Horatius 107
 Horatius, Quintus Flaccus 232
 Horgan, John 476
 horizon 285, 315, 599, 710
 Horne, M.A. 604
 horror vacui 458
 Horváth, Gábor 401
 hot air balloon 383
 hot air balloons 365
 hour 813
 Howell, J.C. 535
 Hoyle, F. 476
 Hoyle, Fred 296, 333, 467, 726
 Hoyt, S. 516
 Htun, Bo Bo 472
 Hu, Z. 405
 Hubble constant 285
 Hubble space telescope 861
 Hubble time 705
 Hubble, Edwin 285
 Huber, A. 401, 841
 Hudson, R.P. 226
 Hughes, David W. 225
 Hughes, R.J. 332
 Huiberts, J.N. 407
 human 831
 human eye 363
 human growth 39
 human language 424, 425
 human sciences 439
 human Y chromosome 831
 Humboldt, Alexander von 404
 humor, physical 861
 humour 163
 Humphreys, Roberta 221
 Hunter, D.J. 219
 Huppertz, H. 407
 hurry 201
 Hurwitz, Adolf 850
 Huygens, Christiaan 61, 85, 362, 864
 hydrargyrum 837
 hydrogen 394, 831, 836
 hydrogen atoms 513, 517
 hydrogen fusion 287
 Hypatia 423, 446, 472
 hyperbolas 261, 315
 hyperbolic 91
 hypernovae 282
 hyperreals 850
 hypersurfaces 203
 hypotheses 443
 Hänggi, P. 604
- I**
- i.e. 808
 Icarus 261, 326
 ice age 288, 410
 ice ages 78, 221, 466
 iceberg 63
 icon 423
 icosane 152
 idea, platonic 703
 ideal 41, 46, 854
 ideal gas 150
 ideas, green 447
 idem 808
 Identity of gravitational and inertial mass 273
 identity, extremal 719
 Ifrah, G. 807
 ill-tempered gaseous vertebrates 445
 Illich, Ivan 468, 618, 859, 860
 illuminance 817
 illumination 470
 illusions, optical 861
 Imae, Y. 219
 image 59, 423
 images 35, 369
 Images 650
 imaginary 845
 imaginary mass 194
 imaginary number 194
 imagination 415
 imagine 128
 Imbrie, J. 221
 immediate 546
 impact 193
 impact parameter 258
 impact parameters 316
 impenetrability 63, 396
 impenetrability of matter 37, 487, 533
 impenetrable 37, 648
 InAs:Mn 392
 incandescence 299, 391, 396, 397, 480
 inclination of earth's axis 78
 incubation 470
 independent 179
 independently 120, 427
 indeterminacy relations 484
 index 362, 423
 index, negative refraction 403
 indigo, violet 366
 indistinguishable 377, 519
 indium 837
 individuality 34, 107
 inductions 136, 870
 inertia 59
 inertial 176
 inertial frame (of reference) 205
 inertial frame of reference 176
 inertial mass 95
 infinite 459
 infinite dimensional 856
 infinitely small 788
 infinitesimals 435
 infinities 54, 452
 infinity 27, 38, 42, 45, 430
 Inflation 287
 inflation 303, 327
 information 154
 information in the universe 716
 information table 434
 infrared 365
 infrared rays 167
 inhomogeneous Lorentz group 526
 initial conditions 107, 286, 298, 358
 injective 430
 ink fish 661
 Innanen, Kimmo A. 223
 inner product 852
 inner product spaces 852
 InP 395
 InSb 392
 insects 90, 363
 instability of solar system 410

- instant 37, 40
 instant, single 27
 instantons 633
 instruments 448
 insulation 391
 insulation power 154
 insulators 342
 integers 435
 integration 48, 117
 intention 465
 interacting 539
 interaction 35, 102, 415, 454
 interaction, fundamental 102
 interaction, is gravity an 276
 interactions 720
 interdependence 545
 interference and photons 500
 interference 362, 538
 interference fringes 499
 interferometer 62, 75, 177
 interferometers 590, 818
 intermediate black holes 323
 intermediate bosons 512
 internal 128, 637
 internal photoelectric effect 394
 International Earth Rotation Service 221, 222, 818
 International Latitude Service 76, 221
 internet 858, 859
 Internet Pilot to Physics 860
 interpretation of quantum mechanics 538, 555
 interstellar gas cloud 410
 intersubjectivity 444
 interval 196
 intrinsic 68, 262
 intrinsic angular momentum 507
 intrinsic properties 647
 invariance 63, 129, 344
 invariance, conformal 203
 invariant 461
 invariant property 126
 invariants 279
 inverse element 129
 inversion 202, 663, 719
 inversion symmetry 203
 invisible 57
 involution 854
 iodine 837
 ionic radii 840
 ionisation 391
 ionization 393
 ionosphere 379, 380
 IRA or near infrared 366
 IRB or medium infrared 365
 IRC or far infrared 365
 iridium 837
 iron 391, 392, 837
 irradiance 817
 irreducible 131
 irreducible mass 320
 irreducible radius 320
 irreversible 152, 541
 Isham, C.J. 695
 Island, Experience 26
 isolated system 155
 isomorphism 131
 isotope mass list 840
 isotopes 525, 831, 834, 841
 isotropic 264
 Israel 318
 italic typeface 423, 801
 Itano, W.M. 405
 IUPAC 825, 841
 IUPAP 825
 Ivanov, Igor 19
 Ives, H.E. 228
J
 J. Gould, Stephen 841
 Jackson, J.D. 345, 401
 Jackson, John David 816
 Jackson, L. 473
 Jacobi identity 854
 Jacobs, J.P. 699
 Jacobson, J. 515
 Jacobson, T. 757
 Jacobson, Ted 666
 Jaekel, M.-T. 696
 Jahn, O. 225
 Jalink, Kim 18
 James, M.C. 223
 Jammer, M. 222
 Janssen, Jules 509
 Jauch 688
 Jauch, W. 698
 Jean-Marc Levy-Leblond 100
 Jeanloz, R. 405
 Jefimenko, Oleg D. 401
 Jenkins, F.A. 227
 Jensen, Hans 809
 jerk 107, 218
 Jesus 83
 jets 382
 Jetzer, P. 333
 jewel textbook 231
 Jin, Y. 605
 Johannes Pelt 301
 John Wheeler 335
 Johnson, Ben 52
 Johnston, K.J. 219
 John Archibald Wheeler 314
 Jones, Gareth 825
 Jones, H. 802
 Jones, P.D. 407
 Jones, Quentin David 19
 Jones, T.B. 405, 406
 Joos, E. 602, 608
 Jordan, P. 630
 Jordan, Pascual 482, 484
 Joseph Taylor 332
 Joseph von Fraunhofer 569
 Josephson constant 646
 Josephson effect 392
 Joule 67
 joule 812
 Joule, James Prescott 148
 Journal of Irreproducible Results 659
 Joutel, F. 223
 Joyce, James 545
 juggling 218
 julian calendar 807
 Julius Robert Mayer 148
 jump 82
 jump, long 221
 Jupiter 100, 124
 Jupiter's moons 101
 Juskiewicz, R. 334
 Jürgens, H. 162
 Jürgens, Hartmut 47
K
 Kac-Moody algebra 856
 Kalbfleisch, G.R. 228
 Kalckar, Jørgen 254, 331
 kaleidoscope 303

- kalium 838
 Kampen, N.G. van 227
 Kanada Yasumasa 826
 Kanno, S. 608
 Kant, Immanuel 37, 280, 285, 333, 427
 kaon 830
 kaons and quantum gravity 691
 Kapuscik, E. 229
 Kardar, R. Golestanian, M. 606
 Karlhede, A. 336
 Karliner, M. 756
 katal 450
 Kauffman, Louis H. 667, 857
 Kauffmann, S. 638
 Kaufmann, W.J. 282
 Kawagishi, I. 219
 Kawamura, M. 666
 Kay, Paul 403
 Keating 235
 Keating, Richard E. 229, 330
 Keesing, R.G. 216, 825
 kefir 124
 Keller, C. 516
 Kells, W. 841
 Kelly, D.D. 798
 Kelu, Jonatan 19
 Kelvin 67, 141, 148, 341
 kelvin 811
 Kelvin, W. 757
 Kempf, A. 697
 Kenderdine, M.A. 219
 Kennard, E.H. 214, 608, 696
 Kennedy, R.J. 228
 Kepler 89, 227, 315
 Kepler's relation 256
 Kepler, Johannes 83, 89, 293, 584
 Kerr effect 394
 Kerr, R. 335
 Kerr, Roy 318
 ketchup 347
 Ketchup motion 39
 Kettering, C.F. 400
 Kidd, R. 515
 Killing form 855
 kilogram 811
 kilogram, prototype 326
 Kim Song-Man 472
 Kimble, H.J. 405
 kinematics 51, 102
 kinesin 562
 kinesiology 442
 kinetic energy 66, 73
 Kirchhoff, Gustav 509
 Kirlian effect 339
 Kittinger 237, 329
 Kittinger, Joseph 232
 Kjellman, J. 228
 Klaus von Klitzing 574
 Klebanov, I. 756
 Klein, O. 630
 Klein, Oskar 510
 Kleppner, Daniel 332
 Klett, .. 667
 Kloor, H. 515
 Klose, S. 336, 608
 knot theory 589
 KnotPlot 663
 knowledge 448
 Knuth, D. 475
 Knuth, Donald 435
 Knutsen, H. 333
 Kochen, S. 604
 Koecher, M. 857
 Koeman, N.J. 407
 Kohlrausch, Friedrich 476
 Konishi, K. 697
 Koolen, Anna 18
 Koomans, A.A. 226, 400
 Koul, R.K. 757
 Kovetz, A. 405
 Kowalski, L. 404
 Kozhekin, A.E. 403
 Kreimer, Dirk 589, 607, 752
 Kreuzer 240
 Kreuzer, L.B. 330
 Krijn, Marcel 18
 Krogh, A. 418
 Krotkow, R. 223, 330
 Krumm, P. 331
 Kruskal, Martin 435
 Kryowonos, A. 516
 krypton 837
 Kubala, Adrian 19
 Kudo, S. 219
 Kuiper belt 99, 124
 Kumaraditya, K.K. 334
 Kurizki, G. 403
 Kurths, Jürgen 222
 Kuscer, I. 516
 Kusch, K. 414
 Kusch, S. 414
 Kuzin, Pavel 19
 Kuzmich, A. 403
 Kvale, E.P. 220
 Kwait, Paul G. 403
 Kötter, K. 227
 Kötter, Klaus 160
 Künzle, A.K.M.
 Masood-ul-Alam, H.P. 335
 Küstner 221
 Küstner, Friedrich 76
- L**
 La Caille 84
 Lachière-Rey, J.-P. Luminet, M. 334
 ladder, sliding 80
 lady 662
 LAGEOS 331
 Lagrange 125
 Lagrange's equations of motion 119
 Lagrange, Joseph 845
 Lagrange, Joseph Louis 115
 Lagrangia, Giuseppe Luigi 115
 Lagrangian 245
 Lagrangian (function) 115
 Lagrangian libration points 92
 Lagrangian of the electromagnetic field 351
 LaH 395
 Lakes, Rod S. 228
 Lalande 84
 Laloë, F. 514
 Lamas-Linares, A. 535
 Lamb 248
 Lamb shift 583, 646
 Lamb, Frederick 336
 Lambeck, K. 220
 Lamoreaux, S.K. 606
 lamps 496, 575
 Lancaster, George 224
 Landau, L. 332
 Landauer, R. 474
 Landauer, Rolf 226
 Landolt-Börnstein 476
 Lang, C.A. Whitney, K.R. 56
 Lang, N.D. 404

- Langel, R.A. 515
 language 413
 language, human 424
 language, spoken 424
 language, written 424
 languages spoken by one person 434
 lanthanoids 834
 lanthanum 837
 Lao Tse 789, 797
 Laplace, Pierre 314
 Laplace, Pierre Simon 92
 Large Electron Positron ring 175
 large number hypotheses 591
 large number hypothesis 712
 larger 191
 Larraza, A. 606
 Larsen, Jeffrey 221
 laser 575
 laser activity 395
 laser beam 371
 laser cavities 494
 laser distance measurement of moon 227
 laser sword 532
 laser swords 511
 lasers 497, 575
 Laskkar, J. 223
 Lasota, J.P. 335
 lateral force microscopes 106
 lateralization 360
 Latham, J. 404
 Latin 808
 Laughlin, R.B. 605
 Laughlin, Robert 574
 Lavoisier, Antoine 472
 law 451
 law of nature, first 414
 Lawrence, Ernest 837
 lawrencium 837
 laws are laziness 440
 laws of nature 415, 462
 laziness 440
 laziness of physics 440
 Le Bellac, M. 407
 lead 139, 837
 leap day 807
 learning 33, 418
 learning mechanics 103
 least effort 125
 Lebedev, Peter 402
 lecture scripts 861
 Lee, J. 697, 757
 Lee, Raymond L. 401
 leg 86, 87
 Lega, Joceline 227
 Legendre, A. 802
 Leggett, A.J. 602, 603
 Lego 144, 480
 lego 722
 legs 25
 Lehmann, Paul 809
 Leibniz 65, 89, 115, 117, 120, 216
 Leibniz, G. 802
 Leibniz, Gottfried Wilhelm 54
 Leiderer, P. 607
 Leighton, R.B. 214
 Lemaître, Georges A. 289
 length 44, 47, 55, 165, 671
 length contraction 183, 229
 length scale 158
 Lenin 348, 681
 Lennard, J. 803
 Lense, Hans 250
 Lense, J. 331
 Lenstra, J.K. 534
 Leo 98
 Leonardo da Vinci 506
 LEP 175
 Leppmaier, Max 606
 Lerner, L. 332
 Lesage, George-Louis 224
 Lesage, Georges-Louis 100
 Leschiutta 235
 Leschiutta, S. 330
 Leucippos 458
 Leucippos of Elea 144
 Levine, Peter A. 604
 levitation 92, 369, 388, 393
 levitation, human 390
 Levitron 406
 Levy-Leblond, J.-M. 407
 Levy-Leblond, Jean-Marie 514
 Libra 98
 librations 90
 Lichtenberg, Georg Christoph 413
 Lichtenberg, Georg Christoph 468
 Lide, David R. 809
 lie 443, 445
 Lie algebra, finite-dimensional 855
 Lie multiplication 854
 Lieb, E.H. 630
 lies 18
 life 558, 559
 life appearance 287
 lifetime 830
 Lifshitz, E. 332
 light 104, 171, 366, 493
 light acceleration 171
 light beams, twisting 369
 light bulb temperature 147
 light deflection 95, 326
 light dispersion and quantum gravity 691
 light does not move 277
 light hitting light 511
 light mill 104, 369
 light onion 707
 light pulses, circling each other 246
 light source 497
 light speed, finite 293
 light swords 511
 light tower 39
 light, angular momentum of 370
 light, longitudinal polarization 172
 light, macroscopic 547
 light, made of bosons 533
 light, massive 172
 light, slow group velocity 216
 light, the unstoppable 172
 light, weighing of 192
 lightlike 181
 lightlike geodesics 276
 lightning 21, 170, 341, 344, 381
 Lilley, Sam 328
 Lilliput 649
 limit on resolution 368
 limit values for measurements 678
 Lincoln, Abraham 472

- Lindblad, G. 603
 Linde, Johan 19
 Linderholm, Carl E. 842
 Lindh, A.G. 331
 line 663
 linear 854
 linear algebra 853
 linear spaces 851
 linear vector spaces 851
 linearity 45
 linearity of electromagnetic field 361
 linearity of quantum mechanics 537
 Linfield, R.P. 230
 linguists 413
 liquid 270
 liquid crystal effect 394
 liquid crystals 394
 liquids 395
 Lissauer, J.J. 223, 227
 list of properties 828
 lithium 837, 840
 litre 813
 Liu Gang 472
 Liu, C. 216
 Livingston, James D. 339
 lizard 82
 Lloyd, Seth 227
 lobbyists 442
 local 112, 682
 local time 40
 locality 460, 552
 localization (weak, Anderson) 391
 Lockyer, Joseph 509
 locusts 82
 Lodge, Oliver 75, 411
 logarithms 89
 logicians 413
 Loll, R. 697
 Lombardi, Luciano 19
 Lombardo, F. 336
 long jump 52, 221
 Longair, M. 286
 Lorentz acceleration 349
 Lorentz gauge 351
 Lorentz relation 350
 Lorentz symmetry breaking and quantum gravity 691
 Lorentz transformations of space and time 178
 Lorentz, H.A. 229
 Lorentz, Hendrik A. 349
 Lorentz, Hendrik Antoon 178
 Loss, D. 603
 Loudon, R. 515
 loudspeaker 170
 Lovász, P. 534
 low 126
 low temperature-physics 150
 Low, R.J. 231
 lower frequency limit 365
 lowest speed 36
 lowest temperature 150
 Ludvigsen, Malcolm 328
 Lui, A.T.Y. 515
 Luigi Galvani 383
 Luke, Lucky 173
 lumen 812
 luminary movement 493
 luminescence 395
 luminous bodies 493
 luminous pressure 395
 lunar calendar 40
 Lundmark 284
 Lundwerk 285
 lutetium 837
 Luther, A. 630
 Luttinger, J.M. 630
 lux 812
 LW 365
 Lämmerzahl, C. 336, 607
 Lévy-Leblond, Jean-Marc 214, 400
- M**
- M theory 715
 Maan, Jan Kees 405
 Macdonald, A. 335
 MacDonald, G.J.F. 220
 mach 62
 Mach 306
 Mach's principle 62, 273, 306
 Mach, Ernst 62
 machine 58, 558
 macroscopic motion 326
 macroscopic system 545
 macroscopically distinct 538
 Mac Callum, M.A.H. 335
 Maddox, J. 757
 Maddox, John 603
 Madelung, O. 476
 Madison, K.W. 605
 Maekawa, Y. 219
 Maeterlink, Maurice 461
 Maffei, Paolo 337
 Maffi, Luisa 403
 Magariyama, Y. 219
 Magellanic clouds 280
 Maggiore, M. 697
 magic 462, 650, 861
 magic moment 414
 magic moments 470
 magnesium 837
 magnet 390
 magnetar 340
 magnetic charge 640
 magnetic circular dichroism 392
 magnetic effects 104
 magnetic field 339, 349, 349
 magnetic flux density 349
 magnetic induction 349
 magnetic monopole 360
 magnetic monopoles 633
 magnetic pole in a mirror 359
 magnetic resonance 393
 magnetic thermometry 226
 magnetic vector potential 354
 magnetism 62
 magneto-Seebeck effect 393
 magnetoacoustic effect 393
 magnetocaloric effect 393
 magnetoelastic effect 392
 magneto-optical activity 392
 magneto-resistance 391
 magnetorheologic effect 393
 magnetostriction 392
 magnets 339
 magnitudes 133
 Magnus, Albertus 627
 Magueijo, J. 698
 Magyar 576
 Mahoney, Alan 19
 Mahowald, M. 474
 Maimonides, Moses 675
 main result of modern science 156
 Main, Peter 406

- Mainwaring, S.R. 229
 Mainzer, K. 857
 Majid, S. 695, 757
 Makhanov, V.G. 629
 Malin, D. 56
 Malus, Louis 363
 mammals 288, 386
 mammals appear 288
 man, wise old 119, 201
 Mandel 576
 Mandel, L. 515
 Mandelbrodt, Benoit 140
 Mandelstam, S. 630
 Mandelstam, Stanley 224
 manganese 837
 Manhattan 342
 manifold 179, 680
 Manly, P. 57
 many types 430
 many worlds interpretation 555
 many-body problem 164
 mapping 431
 marble, oil covered 64
 Marhl, M. 227
 Marian von Smoluchowski 148
 Mark, M.B. van der 401
 Mark, Martin van der 19
 Markow, T. 666
 Markus, M. 227
 Marmo, G. 695
 marriage 413
 Mars 261, 572
 Martin, S. 407
 Marx, Groucho 804
 Marzke, R.F. 335
 Masafumi, Ata 18
 maser 235, 370
 mass 61, 104, 165, 189, 272, 408
 mass defect, measurement 192
 mass point 56
 mass, centre of 98, 194
 mass, Galilean 62
 mass, gravitational 95
 mass, identity of gravitational and inertial 96
 mass, imaginary 194
 mass, inertial 59, 95
 mass, negative 63, 64, 389, 688
 match boxes and universe 709
 material science 830
 material systems 212
 materials, dense optically 502
 math forum 861
 mathematical physics 859
 mathematicians 413, 426, 437
 mathematics 38, 426, 438, 859
 mathematics is applied physics 427
 matrix, adjoint 131
 matrix, antisymmetric 131
 matrix, complex conjugate 131
 matrix, orthogonal 131
 matrix, real 131
 matrix, symmetric 131
 matrix, transposed 131
 matter 56, 60, 793
 matter and antimatter, indistinguishability 685
 matter and vacuum, mix-up 688
 Matter domination 287
 matter shell, gravity inside 99
 matter, composite 830
 matter, impenetrability of 37
 matter, metastable 315
 Matthews, Robert 223
 Mattick 169
 Mattick, A.T. 227
 Mattis, D.S. 630
 Mauna Kea 572
 Mavromatos, N.E. 698
 maximal ideal 854
 Maxwell 341, 346, 348, 450, 848
 Maxwell's demon 421
 Maxwell, James Clerk 352, 655
 Mayer, Julius Robert 67
 Mayer, N.J. 473
 Mayné, Fernand 18
 Mayr, Peter 19
 Mazur 318
 Mazur, P.O. 335
 McCrone, J. 605
 McCulloch 404
 McDonald, K.T. 331
 McDonald, Kirk T. 403
 McGowan, R.W. 228
 McKellar, B.H.J. 230
 McLaughlin, William 214
 McMahan, T.A. 225
 McMahon, Thomas A. 221
 McNamara, Geoff 241
 McQuarry, George 19
 McTaggart 443
 Mc Kellar, Bruce H.J. 516
 Mead, C.A. 696, 756
 meaning 28
 measurability 38, 42, 45
 measure 165
 measured 551
 measurement 38, 421, 449
 measurement apparatus 554
 measurement limits 692
 Measurements 548
 measurements and gravitation 165
 measurements disturb 555
 mechanics 101
 medal, Fields 663
 medicines 25
 Meetz, Kurt 357
 Megrez 300
 Meissner effect 393
 Meitner, Lise 837
 meitnerium 837
 memories 451
 memorize 33
 memory 36, 152, 181, 417, 548
 memory, write once 422
 Mena Marugán, G.A. 334
 Mende, P.F. 697
 Mendeleiev, Dimitri Ivanovitch 837
 mendeleevium 837
 Mendoza, E. 163
 Mensky, M.B. 514
 menstrual cycle 90, 222
 Merckx, Eddy 67
 Mercury 93, 261
 mercury 391, 394, 837
 meridian 86
 Mermin, D. 609
 Mermin, David 396
 Merrit, John 19
 Meschede, D. 405
 mesoscopic 482
 Mesozoic 288
 metacentric height 579

- metal alloys 392
 metal multilayers 391, 392
 metallic shine 394
 metallurgy 164
 metals 396, 834
 metaphor 464
 meter bar 708
 meter bars 111, 309
 metre 811
 metric 196, 201
 metric connection 276
 metric space 680, 851
 metricity 38, 42, 45
 Mettrie, J. Offrey de la 163
 Meyenn, K. von 516
 Meyer, D. 697
 Michael Faraday 351
 Michaelson, P.F. 820
 Michel, Stanislav 65
 Michell, J. 335
 Michell, John 314
 Michelson, A.A. 229
 Michelson, Albert 75, 411
 Michelson, Albert Abraham 177
 microscope 482
 microscope, atomic force 145, 872
 microscopic 482
 microscopic system 544
 microwaves 365
 Mie 395
 migration 624
 Mikkola, Seppo 223
 Milankovitch, Milutin 77
 mile 813
 milk 21
 milky way 280
 million dollars 454
 Milonni, P.W. 515, 606
 Milton, K.A. 400
 mind 555
 Mineyev, A. 225
 mini comets 99
 minimum 505
 Minkowski space-time 179
 Minkowski, Hermann 179
 Minnaert, Marcel 372
 Minnaert, Marcel G.J. 59
 Mintaka 300
 minute 813, 824
 Mirabel, I.F. 216
 miracles 445, 468
 mirror 359, 376, 378, 501, 593
 Mishra, L. 231
 Misner 272
 Misner, C.W. 695, 757
 Misner, Charles 231, 329
 Misner, Charles W. 809
 Mitskievic, N.V. 334
 Mittelstaedt, H. 334
 Mittelstaedt, M.-L. 334
 mixed state 539
 mixture of light 371
 Mo 392
 mobile phone 339
 model 637
 modern calendar 808
 moduli space 641
 Mohazzabi, P. 223, 329
 Mohideen, U. 606
 Mohr, P.J. 825, 828
 mole 525, 811
 molecular motors 560
 Molecular size 646
 molecule 246
 molecules 144
 Molière 468
 molybdenum 837
 momenergy 198
 moment 41
 moment of inertia 67, 68, 133
 momentum 61, 64, 66, 104, 125, 198
 momentum conservation 79
 momentum, flow of 102
 momentum, relativistic 190
 monism 794
 Monitz, E.J. 219
 monochromatic 371
 monocycle 60
 monopole, magnetic 628
 monopoles 354
 Monroe, C. 603
 Monten, C.H. 515
 Montgomery, H. 404
 month 807
 Montie, E.A. 401
 Montonen, C. 756
 Montonen, Claus 361
 moon 21, 85, 326, 378
 moon calculation 85
 moon formation 287
 moon pahse 99
 moon path around sun 97
 moon size, apparent 84
 moon's atmosphere 158
 Moon, F.C. 405
 moon, fall of 85
 moon, laser distance measurement 227
 Moore, Henry 264
 Moore, J.A. 225
 Moothoo, D.N. 402
 morals 111
 Morely, Edward William 177
 Morin, Bernard 663
 Morin, J.-P. Petit, B. 667
 Morley, E.W. 229
 Morrow, P.R. 605
 Moser, Lukas Fabian 19
 motion 35, 111, 233
 motion and measurement units 812
 motion as illusion 27, 563
 motion backwards in time 485
 motion does not exist 27, 180
 motion is change of position with time 51
 motion is the change of state of objects 35
 Motion Mountain 26
 motion mountain 787
 motion of continents 39
 motion of images 409
 motion reversibility 358
 motion, faster than light 155
 motion, hyperbolic 206
 motion, manifestations 26
 motion, passive 105
 motion, superluminal 186
 motion, voluntary 105
 motion, drift-balanced 216
 motion, non-Fourier 216
 motor 170
 motor, electrostatic 104
 motor, linear 104
 mountain 194
 movement 30
 moves 37

- movie 480
 movies 532
 moving 184
 Mozart 470, 562
 Mozurkewich, D. 219
 mozzarella 483
 mu-metal 380
 Mugnai, D. 404
 Mulligan, J.F. 219
 multiple universes 657
 multiplet 129, 130
 multiplication 129, 433
 multiplicity 746
 Muniain, J.P. 758
 Munk, W.H. 220
 muon 828
 muon neutrino 828
 muons 229
 Muramoto, K. 219
 Murdock, Ron 18
 Mureika, J.R. 224
 Murphy, R. 802
 muscles 435, 560
 music record 186
 Musiol, Gerhard 391
 Muynck, Wim de 19
 MW 365
 mycoplasmas 567
 myons 229
 myosin 561
 myosotis 126
 mysteries 445
 mystery 26
 myths 382
 Mössbauer effect 235
 Mößbauer effect 396
 Müller, J. 336
 Møller, C. 231
- N**
- n-Ge 392
 n-Si 392
 n-th harmonic generation 396
 nabla 802
 Nagano, M. 337
 Nagendra Nath, N.S. 630
 Nahin, Paul J. 229
 Nairz, O. 516
 Nakazato, H. 605
 naked singularities 323, 689
- Namba, K. 219
 Namiki, M. 605
 Nanopoulos, D.V. 698
 nanoscopic 482
 Nansen, Fridtjof 220
 Napoleon 92
 NASA 861
 Nassau, K. 59
 Natarajan, V. 230
 natrium 839
 natural 46
 natural numbers 433
 natural sciences 439
 nature 35, 414, 554, 792
 Nauenberg, M. 222, 618
 Navier-Stokes equations 164
 Nb-Oxide-Nb 392
 Ne 392
 Needham, Joseph 224
 negative 263, 342
 negative group velocity 375
 negative mass 688
 Nemiroff, R.J. 331
 neodymium 837
 neon 837
 Neptune 99, 100
 neptunium 837
 Nernst effect 393
 nerve signal speed 39
 nerve signals 474
 nerves 348
 Nesvizhevsky, X. 607
 network 418
 Neuhauser, W. 225, 405
 Neukirch, J. 857
 Neumann, Dietrich 90, 222
 Neumann, John von 538, 552
 neural networks 418
 neurologists 413
 neurons 418, 422, 435
 neutral bodies 342
 neutral element 129
 neutralino 829
 neutrino 145, 176, 201, 212,
 229, 287, 540, 572, 619,
 623, 625
 neutrino, electron 828
 neutron 511, 830
 neutron star 124, 340
 Neve, Erik de 663
- New, M. 407
 Newcomb, Simon 93, 223
 Newman, E.T. 335
 newspaper 226
 Newton 43, 64, 72, 89, 102,
 115, 167, 216, 306, 503
 newton 812
 Newton 819
 Newton, Isaac 37, 84
 Newtonian physics 37, 102
 Ng 702
 Ng, Y.J. 696, 720
 Ni 392
 Niagara 141, 163
 nickel 837
 Nicolis, Grégoire 227
 Niederer, U. 134
 Niels Bohr 170
 Nielsen, H.B. 629
 Nieminen, T.A. 402
 Nienhuis, G. 516
 Nieto, L.M. 331
 Nieto, M.M. 516
 Nieuwpoort, Frans van 19
 Nightingale, J.D. 224, 328
 Nimtz, G. 403
 Nimtz, Günter 375
 Niobe 837
 niobium 391, 837
 nitrogen 146, 837
 Niu, Q. 605
 no 309, 426
 no-cloning theorem 525, 535
 Nobel, Alfred 837
 nobelium 837
 noble gases 834
 node 359
 Noether charge 136
 Noether's theorem 135
 Noether, Emmy 135
 noise 148, 420
 noise thermometry 226
 non-cantorian 474
 non-rigid extended bodies 113
 non-stationary 388
 non-unitarity 555
 nonclassical 497
 nonclassical light 495, 498
 nonius 51
 nonlocal 545

- nonstandard analysis 850
 Nordström, G. 318
 Nordvedt effect 336
 norm 55, 843, 845
 normal 824
 normal distribution 149
 normality 826
 normed 845, 852
 north pole 43, 76, 88, 237, 297, 349, 410, 507
 North Whitehead, Alfred 451
 Norton, John D. 331
 nose 562
 Nossak, Ernst Erich 796
 notion 423
 nova 286, 410
 novae 282
 Novikov 285
 Novikov, I.D. 333
 Novikov, Igor 314, 334, 608
 nuclear forces 619
 nuclear reaction 617
 nuclei 104, 287
 nucleon 145
 Nucleosynthesis 287
 nucleus 507
 null geodesics 276
 null vector 197
 null vectors 197
 number of particle 460
 number of stars 712
 number operator 633
 number theory 850
 numbers 133, 437
 nutation 77
 Nutsch, W. 667
 nutshell, general relativity in a 324
 nymphs 647
- O**
- O'Connell, Sanjida 473
 O'Keefe, R. 222
 Oberquell, Brian 19
 object 33, 34, 40, 59, 408, 425, 544
 object, full list of properties 828
 object, levitation 388
- object, moving: means being made of particles 647
 objects 35, 111, 409
 objects, real 194
 objects, virtual 194
 obliquity 77
 observables 35, 133, 450
 observables, discrete 133
 observation 421, 451, 549
 observations 415, 548
 observer 555
 Occam's razor 745
 Occam, William of 745
 ocean level 410
 ocean levels 410
 Ockham, William of 745
 octaves 849
 octet 132
 octonions 849, 854
 odometer 47, 197
 Oersted 348
 Oersted, Hans Christian 348
 Offrey de la Mettrie, J. 163
 Ohanian, Hans C. 329, 535, 809
 ohm 812
 Ohm, Georg Simon 379
 Ohno, H. 406
 oil 64, 394
 oil tankers 378
 Okun, Lev B. 230
 Olbers 293
 Olbers, Wilhelm 293
 Olive, D. 756
 Olive, David 361
 Olmsted, J.M.H. 218
 Olum, K.D. 330
 Olympus mons 572
 omega 831
 one million dollar prize 164
 one-body problem 585
 only 194
 only one thing at a time can be at a given spot 37
 onto 430
 ontological reach 458
 Oort cloud 99, 124, 410
 Opel 341
 openness 42, 45
 operator 87
- Ophiuchus 99
 Oppenheimer, J. 697
 Oppenheimer, R. 335
 Oppenheimer, Robert 121, 315, 472
 opposite 426, 445
 optical activity 394
 optical black holes 595
 optical Kerr effect 396
 optical nonlinear effects 396
 optical radiation thermometry 226
 optically induced anisotropy 395
 optoacoustic affect 396
 optogalvanic effect 396
 orange 366
 Orban, F. 400
 orbits 275
 order 42, 45, 63
 Order 159
 order 344
 order out of chaos 792
 order parameter 161
 order structures 432
 order, partial 181
 ordered pair 430
 ordinal numbers 435
 ordinals 850
 ore-formers 834
 organelles 560
 origin, human 26, 795
 Orion 193, 299
 Ornitzky, A. 534
 oscillation 139
 oscillator 566
 oscillons 160
 osmium 838
 osmosis 104, 157
 Osserman, Bob 302
 Otto, Rudolf 470, 726
 Oughtred, W. 802
 oven 398
 overdescription 356
 Overhauser, A.W. 607
 Ovidius 569
 Oxford 324
 oxygen 146, 838
 oxygen depletion 410
 ozone shield reduction 410

- P**
p-Ge 394
Padgett, M.J. 402
Padgett, Miles 402
Padmanabhan, T. 696
Padua, de 498
Paffuti, G. 697
Page, Don 19, 598
Page, Don N. 335, 608
Pahaut, Serge 18
paint, black 293
pair creation 396
Pair creation 645
Pais, A. 225, 475
Palaeozoic 287
palladium 838
Palmer, R. 418
Pangaea 288
Panov, V.I. 223, 330
Papapetrou, A. 230
paper aeroplanes 862
paper boat contest 139
Pappus 60
parabola 52, 85
parabolas 261, 315
parabolic 91
parachutes 105
paradox of incomplete description 455
paradox of overcomplete description 455
paraelectricity 393
parallax 76
parallaxis 72
parallelepiped 69
paramagnetism 392
parameter 450
parameter space 640
parametric amplification 396
parametrized post-Newtonian formalism 247
parenthesis 803
parity 829
parity invariance 360
Parker, D.E. 407
Parkes, M.B. 809
Parlett, Beresford 32
Parmenides 27, 54
Parmenides of Elea 27
Parmenides, by Plato 746
Parrott, S. 405
particle 56, 523, 671
particle data group 828, 860
particle number 460
particles 522
particles, massive 172
parts 35, 56, 156
parts, sum of 454
pascal 812
Pascal, Blaise 493
Pascasio, S. 605
Pascasio, Saverio 18, 19, 605
Paschen-Back effect 392
passive 30
passive motion 108
past light cone 180
Paterson, Alan L.T. 218
path 52, 489
paths of motion 324
patterns 440
patterns of nature 415
Paul Lehmann 802
Paul traps 390
Paul, H. 515, 606
Paul, W. 230
Pauli exclusion principle 474, 525, 527, 530, 531, 533
Pauli pressure 530
Pauli spin matrices 613, 846
Pauli, Wolfgang 188, 444, 484, 513, 535
Pauling 605
Paulsen, C. 603
Paulus of Tarsus 447
Pb 396
PbLaZrTi 394
PbSe 391
PbTe 391
Peano, G. 802
Pearson, T.J. 230
Pecharsky, Vitalij 406
peers 859
Peeters, Bert 19
Peirce, Charles 446
Peitgen, H.-O. 162
Peitgen, Heinz-Otto 47
Pekár, V. 223, 330
Pelt, Johannes 333
Peltier effect 391
pencil, invention of 37
pendulum 86
penetrability of matter 487
penetration 533
Peng, J.L. 405
penguins 71
Penning effect 392
Penning traps 192, 390
Penrose process 596
Penrose, R. 335, 336
Penrose, Roger 319, 323, 334
Penrose-Hawking singularity theorems 323, 336
Penzias, Arno 285
Penzias, Arno A. 333
people 617
perceptions 415
Peredo, M. 515
Perelman, Yakov 139, 214
Peres, A. 334, 697
perfect copy 525
performers 859
periastron 261
periastron shift 261
perigeon 823
perihelion 93, 261
perihelion shift 78, 326
periodic table 833
Periodic table of the elements 834
Perkins, D.H. 229
permanence 485, 556
permanent 32, 33
permanent free fall 315
permeability 377
permittivity 377
permutation symmetry 129, 522
Perot 235
perpetual motion machine 65
perpetuum mobile 64
Perrin, Jean 149, 226
Perros, Georges 563
Persius 461
person 407
perturbation calculations 309
perverted 467
Pesic, P. 333
Peter the Lombard 475
Peters, A. 607
Petit, Jean-Pierre 861

- Peş ić, Peter D. 605
 Pfister, Herbert 334
 Phaedrus 799
 phase 361, 519
 phase conjugated mirror
 activity 396
 phase factor 356
 phase space 35, 107
 phase space diagram 53
 phase velocity 373
 pheasants 661
 phenomena, supernatural 454
 phenomena, unnatural 454
 phenomenological high energy
 physics 859
 phenomenon 440
 Philips 580
 Phillips, R.J. 222
 philosophers 493
 philosophers of science 413
 Philpott, R.J. 231
 phonological 425
 phosphorescence 395
 phosphorus 838
 photino 829
 photoacoustic effect 158, 396
 photoconductivity 396
 photoeffect 394
 photoelectricity 394
 photoelectromagnetic effect
 392
 photography 394
 photoluminescence 395
 photon 620, 828
 photon decay 308
 photon drag effect 394
 photon sphere 317
 Photon-photon scattering 646
 photonic Hall effect 393
 photons 491, 493, 647
 photons and interference 500
 photons, eye detection of
 single 491
 photons, spin of 493
 photorefractive materials 369,
 395
 photostriction 394
 physical concepts, discovery of
 441
 physical explanation 465
 physical observations 127
 physical system 716
 physicists 860
 physics 25, 439, 442
 physics problems 860
 physics, boring 426
 physics, etymology of 442
 physics, outdated definition 30
 physiology 413
 Piaget, J. 417
 Piaget, Jean 215, 417
 Picasso, Pablo 422, 463
 Piccard, Auguste 146
 piezoelectricity 104, 393
 pigeons 71
 pigs 617, 726
 Pikovsky, Arkady 222
 Pimpinelli, A. 607
 pinch effect 392
 ping-pong ball 81
 Pinker, Steven 216, 474
 pion 830
 Piper 257
 Piper, M.S. 332
 Piran, T. 698
 Pisces 98
 Pitnick, S. 666
 Planck acceleration 689
 Planck length 729
 Planck length, 674
 Planck limit 367
 Planck mass 684
 Planck stroll 817
 Planck time 591, 703
 Planck time. 674
 Planck's (reduced) constant
 480
 Planck's (unreduced) constant
 480
 Planck's constant 397, 492
 Planck's natural units 815
 Planck's quantum of action 397
 Planck, M. 696, 756
 Planck, Max 153, 397, 480,
 497, 498, 514, 728
 plane gravity wave 255
 planet 65
 planet formation 287
 planetoids 125
 plants 25
 plants appear 287
 plasma 281
 plasmas 392, 396
 Plastino, A. 535
 Plastino, A.R. 535
 plate tectonics 76
 platinum 838
 Plato 144, 164, 296, 605, 703,
 725, 746, 758, 799
 platonic ideas 703
 play 30, 440
 Pleiades star cluster 288
 Plinius 214
 plumb-line 50
 plumbum 837
 Plutarchus 112
 Pluto 99
 plutonium 838
 Pockels effect 394
 Podolsky, Boris 603
 Poincaré algebra 856
 Poincaré, Henri 79, 171, 177,
 178, 232, 246, 470, 498, 515
 Poinsot, Louis 74
 point particle 56
 point particles, size of 321
 point-like for the naked eye 57
 pointer 551
 points 37, 57
 poisons 25
 Poisson equation 87
 Poisson's point 368
 Poisson, Denis 368
 Poisson, Siméon-Denis 87
 polar motion 76
 Polaris 124
 polarizability 393
 polarization 363, 394, 503
 polarization of light 493
 Polder, D. 606
 polders 368
 pole, magnetic, in a mirror 359
 polonium 838
 polymer 394, 395
 Pompeius 112
 Pompeius, Gnaeus 112
 pool 190
 pop 218
 Popescu, S. 535
 Popper, Karl 448, 475

- porcine principle 467, 726
 posets 715
 position 556
 positional system 807
 positions 55
 positive 263, 342
 positive or negative 344
 positivity 63
 positron 510
 possibility of knots 45
 post-Newtonian formalism 247
 potassium 838
 potential energy 88
 potential, gravitational 87
 Pound 235
 Pound, R.V. 329
 Povinelli, D.J. 468
 power 199, 817
 power set 429, 430
 power, physical 103
 powerful 440
 Poynting vector 256
 Prakash, A. 335
 praseodymium 838
 praying 125
 precession 78, 262
 precession, equinoctial 76
 precise 41
 precision 28, 36, 38, 51, 165, 175, 446, 819, 820
 precision, maximal 704
 precision, maximum 694
 predicates 425
 predicted 779
 prefixes 813, 824
 prefixes, SI 813
 prejudice 444
 Prentis, Jeffrey J. 515
 Preparata, G. 608
 preprints 860
 presents 211
 presocratics 476
 pressure 103, 143, 150
 pressure of light 402
 Prestel, A. 857
 Preston-Thomas, H. 226
 Prevedelli, M. 401, 841
 Price, R.H. 64
 Prigogine, Ilya 227, 334
 primal scream 596
 primates 386
 primates appear 288
 Principe 329
 principle of equivalence 233
 principle of gauge invariance 128
 Principle of general covariance 273
 Principle of general relativity 273
 principle of least action 118
 Principle of minimal coupling 273
 principle of relativity 128, 177
 principle of the straightest path 108
 principle of thermodynamics, second 181
 principle, anthropic 657
 principle, extremal 115
 principle, physical 440
 principle, simian 657
 principle, variational 115
 principles 273
 printed words 434
 prism 219
 Pritchard, D.E. 230
 Pritchard, David 192
 probability 549
 probability amplitude 554
 problems, physical 860
 process, chemical 192
 process, sudden 110
 processes 152
 Procyon 124, 300
 product set 429
 projection operators 634
 Prometheus 838
 promethium 838
 proof 443
 proper 131
 proper distance 197
 proper time 40, 179, 197
 proper velocity 39, 182
 properties of nature 415
 properties, emergent 163, 455
 protactinium 838
 Protagoras 819
 proton 511, 612, 830
 Proton lifetime 646
 proton mass 646
 proton radius 511
 proton Volt 817
 prototype kilogram 326
 Protozoic 287
 Provero, P. 697
 Pruppacher, .. 667
 Pryce, M.H.L. 230
 pseudo-science 382
 pseudovector 81, 349
 psychokinesis 30
 Ptolemy 50
 public 446
 pulley 104
 pulsar 281
 pulsars 256, 326
 pure 845
 pure blue 366
 pure green 366
 pure red 366
 pure state 538
 pure truth 443
 purpose 465
 Putterman, S.J. 221
 Putterman, Seth J. 406
 pyramid 69
 pyroelectricity 394
 Pythagoras 437
 Päsler, Max 224
 Pérez-Mercader, J. 218
 Pěč, Karel 218
- Q**
- q-numbers 850
 QED diagrams 752
 Qomolangma, Mount 88
 quadrupoles 256
 quanta 647
 quantities 133, 450
 quantities, conserved 27
 quantities, extensive 64
 quantity of matter 61, 63
 quantization 491, 578, 638, 641
 quantum computers 525
 quantum cryptography 525
 quantum electrodynamics 577
 quantum field theory 631
 quantum flavour dynamics 619
 quantum fluctuations 715
 quantum groups 638

- quantum lattices 715
 quantum mechanical system 544
 quantum mechanics applied to single events 555
 quantum numbers 527
 Quantum numbers 829
 quantum of action 397, 480
 quantum of change 480
 quantum particles 648
 quantum principle 480
 quantum ratchets 562
 quantum theory 34, 142, 411
 quark confinement 615
 quark mass 621
 Quarks 287
 quarks 574
 quartets 132
 quartz 393–395
 quasar 123, 186
 quasars 322, 596
 quasistatic fields 365
 quaternions 437, 844, 854
 Quinlan, Gerald 223
 quotations, mathematical 862
 quotes 415
- R**
- radar 173
 radian 813
 radiation 60, 154, 167, 212, 362, 408, 830
 radiation composite 833
 radiation thermometry 226
 radiation, black body 396
 radiation, hermal 396
 radiation, observers made of 556
 Radiative decay 645
 radicals 523
 radio field 339
 radio interference 575
 radio speed 39
 radio waves 362, 365
 radioactivity 519, 610
 radiometer 369
 radiometer effect 395
 radium 838
 radius, covalent 840
 radius, ionic 840
- radon 838
 Rahtz, Sebastian 19
 rain drops 53, 106
 rainbow 133, 362, 368
 Rainer, M. 757
 Raizen, M.G. 605
 Raleigh 395
 Ramaccini, F. 475
 Raman effect 395
 Ramanujan, Srinivasa 89
 Ramberg 525
 Ramberg, E. 535
 Ramsauer, Carl 790
 Ramsay, William 509
 Ramsey, N.F. 698
 Randi, James 30, 475, 476, 659
 Randjbar-Daemi, S. 720
 random 109
 random errors 819
 random pattern 33
 Ranfagni, A. 403, 404
 range 432
 Rankine, William 66
 Ranque-Hilsch vortex tube 158
 Rappmann, R. 473
 ratchet 561
 rational numbers 435
 Rawlins, D. 222
 Rawlinson, A.A. 230
 ray days 167
 ray form 100
 Raymer, M.G. 609, 696
 Raymond, D.J. 231
 rayon vert 372
 rays 167
 reactions 488
 Readhead, A.C.S. 230
 real numbers 42, 45, 435, 437
 reality 415
 reals 435
 reason 465
 Reball, Siegfried 391
 Rebka 235
 Rebka, G.A. 329
 Recami, E. 230
 reciprocal 455
 recognition 524
 recognize 33
 recoil 346
 Recombination 287
- recombination 391
 record 420, 548
 Recorde, R. 801
 Recorde, Robert 801
 rectilinear 206
 Rector, J.H. 407
 red 366, 386
 red shift 173, 308
 red shift mechanisms 308
 red shift number 173
 red shifts 595
 Redondi, Pietro 37, 141
 redshift 326
 reducible 131
 reductionism 466
 reel 28
 reflection 277, 501
 reflectivity 369, 394
 refraction 126
 Refraction 277
 refraction 367, 375, 383, 392, 394, 502
 refraction index, negative 403
 refraction, index of 258
 Regulus 124, 300
 Reichert, J. 401, 841
 Reichl, Linda 149, 226, 407, 602
 Reissner, H. 318
 Reissner-Nordstrom black holes 318
 relation 427
 relation, binary 429
 relational 47
 relations 35, 417, 429
 relative 34, 47
 relativistic acceleration 197
 relativistic contraction 178
 relativistic correction 178
 relativistic jerk 198
 relativistic kinematics 176
 relativistic mass 199
 relativistic velocity 197
 relaxation 541
 religion 445
 reluctance to turn 67
 Remmert, R. 857
 Renaud, S. 696
 renormalizable 631
 Renselle, Doug 19

- representation [131](#), [843](#), [846](#), [849](#)
 representation of the
 observables [134](#)
 representations [130](#)
 reproducibility [127](#)
 Reproduction [559](#)
 research [106](#)
 Research Council Staff,
 National [404](#)
 reservoir [539](#)
 resin [339](#)
 resinous [342](#)
 resistance of single atoms [379](#)
 resistivity, Joule effect [391](#)
 resources [859](#)
 rest [27](#), [53](#), [232](#), [233](#), [480](#)
 rest energy [192](#)
 rest mass [199](#)
 retina [385](#)
 retroreflecting paint [383](#)
 reversal of earth's magnetic
 field [410](#)
 reversible [152](#), [320](#)
 Reynolds, Osborne [402](#)
 Reznik, B. [697](#)
 rhenium [584](#), [838](#)
 Rhodes, C. [607](#)
 rhodium [838](#)
 Ricci scalar [267](#), [269](#)
 Ricci tensor [268](#)
 Richardson effect [392](#)
 Richardson, Lewis Fray [47](#)
 Richtmeyer, F.K. [214](#)
 Ridgeway, S.L. [406](#)
 Rieflin, E. [219](#)
 Rieke, F. [515](#)
 Riemann tensor [278](#)
 Riemann, Bernhard [278](#)
 Riemann-Christoffel curvature
 tensor [278](#)
 riemannian manifold [278](#)
 Riga [124](#)
 Rigel [300](#)
 Righi-Leduc effect [393](#)
 right hand rule [68](#)
 rigid [48](#), [205](#)
 rigid bodies [211](#), [583](#)
 rigid coordinate system [205](#)
 rigidity [183](#)
 Rigor, I.G. [407](#)
 Rikken, Geert [406](#)
 Rimini, A. [607](#)
 Rinaldo, A. [225](#)
 Rindler, W. [229](#), [231](#)
 Rindler, Wolfgang [231](#), [329](#),
 [331](#), [407](#)
 Rindt, Jochen [37](#)
 ring [433](#)
 Rinnooy Kan, A.H.G. [534](#)
 Ritter, Johann Wilhelm [363](#)
 Ritz [228](#)
 Robbins, J.M. [535](#)
 Robert Geroch [593](#)
 Robert Wald [593](#)
 Roberts, J.E. [697](#)
 Roberts, M. [606](#)
 Roberts, P.H. [405](#)
 Robertson, H.P. [289](#), [609](#)
 Robertson-Walker solutions
 [289](#)
 Robinson [318](#)
 Robinson, John Mansley [216](#)
 robot [224](#)
 robotics [846](#)
 Robutel, P. [223](#)
 rock-solid [446](#)
 rocket [319](#)
 rocket motor [104](#)
 rod distance [205](#)
 Rodgers, P. [406](#)
 Rodin, Auguste [85](#), [864](#)
 Rodriguez, L.F. [216](#)
 Roger, G. [603](#)
 Roll, P.G. [223](#), [330](#)
 rolling [70](#)
 Romalis, M.V. [699](#)
 Roman number system [807](#)
 Romanowicz, B. [405](#)
 Rooy, T.L. van [226](#), [400](#)
 rose [462](#)
 Rosen, N. [697](#)
 Rosen, Nathan [603](#)
 Rosenblum, Michael [222](#)
 Rosenfeld [504](#), [713](#)
 Rosenfeld, L. [516](#), [720](#)
 rosetta [316](#)
 rosetta paths [317](#)
 Rostock, University of [139](#)
 rotation [355](#), [532](#), [845](#)
 rotation axis [507](#)
 rotation of the earth [818](#)
 rotation rate [67](#)
 rotation speed [67](#)
 rotational energy [69](#)
 rotational motors [560](#)
 Rothenstein, B. [229](#)
 Rothman, T. [720](#)
 Rottmann, K. [231](#)
 Rovelli, C. [695](#), [697](#), [757](#)
 Roy, A. [606](#)
 Rozental, I.L. [337](#)
 Ruan, J. [629](#)
 Ruben, Gary [19](#)
 rubidium [838](#)
 Rubik's cube [140](#)
 Rubik's cube [434](#)
 Rubinstein, J. [404](#)
 Rubinsztein-Dunlop, H. [402](#)
 ruby [394](#), [395](#)
 Rucker, Rudy [431](#), [474](#), [857](#)
 Ruder, H. [336](#)
 Rudolff, K. [801](#)
 Rudolph Clausius [304](#)
 Ruffini [595](#)
 Ruffini, R. [335](#), [608](#)
 Ruffini, Remo [329](#), [809](#)
 Ruga, Spurius Carvilius [803](#)
 rugby [66](#)
 Ruggieri, R. [404](#)
 rules [440](#)
 rules of nature [415](#)
 Runic script [803](#)
 running on water [222](#)
 Ruppel, W. [223](#), [329](#)
 Rusby, R.L. [226](#), [825](#)
 Rusby, Richard [825](#)
 Ruschewitz, F. [405](#)
 Russel Hulse [332](#)
 ruthenium [838](#)
 Rutherford, Ernest [610](#), [838](#)
 rutherfordium [838](#)
 Rybakov, Y.P. [629](#)
 Rybicki, G.R. [230](#)
 Rydberg constant [646](#)
 Ruffer, U. [667](#)
 Rømer, Olaf [167](#)
S
 S-duality [743](#)

- Sacks, Oliver 473
 Sagan, Carl 720
 Sagittarius 98
 Sagnac effect 75
 Sagnac, Georges 75
 Sahara 434
 Sahl, Mort 468
 sailing 64, 168
 Saiph 300
 Sakar, S. 698
 Sakharov, A.D. 698, 757
 Sakharov, Andrei 472, 684
 Sakur-Tetrode formula 519
 Salam, Abdus 515
 Salamo, G. 402
 Salecker 755
 Salecker, H. 696, 720, 758
 Salingaros, N. 401
 Sally, P. 857
 Salmonella 662
 Salmonson, J.D. 608
 salt 394, 823
 salt-formers 834
 samarium 838
 Saminadayar, L. 605
 sampi 804
 San Suu Kyi..., Aung 224
 sand 160, 434
 Sands, M. 214
 Santander, M. 331
 Sanyuk, V.I. 629
 Sarazin, X. 629
 Sasaki-Shibuya effect 392
 Sastry, G.P. 229
 satellite 362
 satellites 81, 99, 595
 satellites, observable 861
 saturable absorption 396
 saturation 470
 Saturn 93, 99
 Saupe, D. 162
 Saupe, Dietmar 47
 Saussure, Ferdinand de 424
 scalar 127, 133, 851
 scalar multiplication 851
 scalar part of a quaternion 844
 scalar product 55, 852
 scale factor 202, 294
 scale invariance 142
 Scali, Maria 18
 scandium 838
 scattering 395
 Schadt-Helfrichs effect 394
 Schadwinkel, H. 405
 Schaefer, B.E. 228, 698
 Scharnhorst, K. 606
 Schata, P. 473
 Scheer, Elke 404
 Schiff, L.I. 400
 Schild, A. 697
 Schiller, Britta 18
 Schiller, C. 226, 400, 720, 756
 Schiller, Christoph 695, 720, 730, 756
 Schiller, Friedrich 490
 Schiller, Isabella 18
 Schiller, Peter 18
 Schmidt, H.K. 229
 Schmidt, Klaus T. 218
 Schmidt, T. 227
 Schmidt, X. 608
 Schmidt-Nielsen, K. 226
 Schmiedmayer, J. 517
 Schneider, M. 336
 Schneider, P. 334
 Schoeck, Helmut 477
 Schooley, J.F. 226
 Schottky effect 393
 Schrödinger 374, 450
 Schrödinger picture 537
 Schrödinger's cat 537
 Schrödinger's equation 573
 Schrödinger, Erwin 609
 Schubert, M. 514
 Schucking, E. 516
 Schultz, Charles 411
 Schultz, Sheldon 403
 Schutz, B.F. 332
 Schwab, K. 607
 Schwartz, Richard 477
 Schwarz, J.H. 695, 756
 Schwarzschild 235
 Schwarzschild metric 240
 Schwarzschild radius 240, 816
 Schwarzschild, Bertram 516
 Schwarzschild, Karl 240
 Schwenk, K. 227
 Schwinger 578
 Schwinger, J. 516
 Schwinger, Julian 400, 448, 514, 578
 Schwob, C. 401
 Schäfer, C. 476
 Schäfer, G. 336
 Schön, M. 696
 Schönenberger, C. 226, 400
 Sciama, Dennis 307
 science 448
 science fiction 192, 532
 science of symbolic necessities 428, 438
 science, end of 459
 scientific method 442, 446
 scientism 448
 scientist 448
 scissors 185
 Scorpius 98
 Scott, G.G. 400
 Scott, Jonathan 19
 Scott, W.T. 405
 Se 396
 Seaborg, Glenn 838
 seaborgium 838
 search engines 227
 second 811, 813, 824
 second harmonic generation 395
 second principle of thermodynamics 157, 594, 726
 second property of quantum measurements: 549
 sectional curvatures 266
 sedenions 850
 Seebeck effect 391
 seeing 398
 seem 770
 Segev 369
 Segev, M. 402
 Segev, Mordechai 402
 Seidelmann, P. Kenneth 825
 Seielstad, G.A. 230
 selectron 829
 selenium 838
 self-adjoint 131
 self-organization 114
 self-referential 447
 selfsimilarity 47
 semantic 425

- semi-ring 433
 semiconductivity 391
 semiconductors 393
 semimajor axis 261
 semisimple 856
 Semon, Mark D. 401
 Seneca 308, 798
 sensations 415
 senses 479
 separability 344, 545
 separability of the universe 460
 separable 545
 sequence 40, 42, 45, 63, 344
 serious 467
 sesquilinear 852
 Sessa 36
 set 42, 45, 63, 344, 427, 428
 seven sages 339
 sex 25, 30, 87, 518, 721
 Sexl, R. 229
 sextant 222
 Shackleton, N.J. 221
 shadow 167
 shadows 186
 Shakespeare, William 30, 743, 787
 Shankland, R.S. 403
 shape 45, 56, 145, 183
 shape of the earth 98
 shape, optimal 106
 Shapere, A. 667
 shapes 481
 Shapiro, A.H. 220
 Shapiro, Arnold 663
 Shapiro, Asher 73
 Shapiro, I.I. 259, 332
 Sharma, Natthi L. 220
 sharp s 803
 Shaw, George Bernard 443, 505
 Shaw, R. 229
 Shea, J.H. 329
 Shell study 219
 shell, gravity inside matter 99
 Shephard, G.C. 129
 Shepp, L. 534
 SHF 365
 Shih, M. 402
 Shimony, A. 604
 Shinjo, K. 224
 ship 63, 168
 shoe-laces 45
 shoelaces 152
 shore birds 222
 short 485
 shot noise 143
 shot, small 139
 shoulders 71
 Shubnikov-de Haas effect 393
 Shulman, Polly 475
 shutter 50
 shutter time 50
 shutter times 736
 Si 394
 SI prefixes 813, 819
 SI system 345
 SI units 811, 819
 SI units, supplementary 813
 siemens 812
 sievert 812
 sign 423
 signal 376
 signal, physical 373
 Sigwarth, J.B. 223
 silent holes 595
 silicon 391, 392, 839
 Silk, X. 334
 silver 342, 839
 Silverman, M. 219
 Silverman, M.P. 516
 Silverman, Mark P. 99, 609
 simian principle 467, 726
 similar 34
 Simon, C. 535
 Simon, Julia 19, 218
 Simon, M.D. 405, 406
 Simon, M.I. 219
 Simon, R.S. 230
 Simoni, A. 695
 simple 856
 Simpson, N.B. 402
 sine curve 139
 Singh, T.P. 336
 single atom 379, 547, 566, 575, 585, 688
 single events in quantum mechanics 555
 Singleton, D. 404
 Singleton, Douglas 19
 singlets 132
 singular 131
 singularities 275, 333, 774
 singularities, naked 323
 singularity, naked 410
 sink vortex 220
 Sirius 124, 300, 330
 Sitter, W. de 332
 situation 34
 size 44
 skew field 433
 skew-symmetric 131
 skin 57, 366, 371
 skin effect 392
 sky 21, 299, 395
 Skyrme, T.H.R. 629
 skyrmions 634
 Slater, Elizabeth M. 381
 Slater, Henry S. 381
 Slavnov, A.A. 758
 sleeping beauty effect 376
 slingshot effect 97
 sloth 440
 slow motion 195
 Smale, S. 667
 Smale, Stephen 662
 smallest experimentally probed distance 50
 Smekal-Raman effect 395
 smiley 803
 Smirnov, B.M. 404
 Smith, J.B. 229
 Smith, J.F. 603
 Smith, Steven B. 807
 Smolin, L. 638, 697, 698
 Smullyan, Raymond 447
 smuon 829
 snake 99
 snap 218
 sneutrino 829
 Snider, J.L. 329, 330
 snooker 190
 Snow 525
 Snow, G.A. 535
 snowboard 183
 snowboarder 183
 snowflakes 434
 Snyder, H. 335
 Snyder, H.S. 697
 Snyder, Hartland 315
 soap bubbles 146

- Sobral 329
 Sockman, Ralph W. 610
 Socrates 163, 799, 858
 sodium 839
 Soffel, M. 336
 Soffel, Michael H. 337
 Sokolow, A. 630
 solar cells 394
 solar sail effect 395
 solar system 124
 solar system formation 75
 solar system simulator 861
 Soldner 258, 259
 Soldner, J. 223, 330
 Soldner, Johann 95, 245
 solid bodies 211
 solid body, acceleration and length limit 211
 solid state physics, in society 396
 solidity 391, 396
 solitons 633
 Solitons 635
 solvable 855
 Sommerfeld, Arnold 374, 403, 513
 Sonett, C.P. 220
 Sonoda, D.H. 334
 sonoluminescence 80, 395
 Sorabji, R. 698
 Sorkin, R.D. 695, 697, 757
 souls 647
 sound 368
 sound waves 173
 source 87
 sources 87, 575
 south pointing carriage 224
 south pole 88, 348, 410
 south-pointing carriage 113, 279
 soviets 348
 Spaarnay 580
 space 111, 797
 space of life 308
 space points 57
 space travel 80
 space, mathematical 715
 space, physical 44
 space, white 803
 space-time 35, 179
 space-time diagram 53
 space-time duality 743
 space-time foam 601
 space-time interval 179
 space-time lattices 715
 space-time, absolute 47
 space-time, fundamental 47
 spacelike 181, 197
 spacelike convention 196
 spanned 550
 spanners, optical 370
 Sparenberg, Anja 406
 sparks 345
 Sparnaay, M.J. 606
 spatial inversion 135
 special conformal transformations 202
 Special Orthogonal group 846
 special relativity 171
 special relativity before the age of four 128
 specific 444
 specific lie 446
 specific mechanical energy 225
 Specker, E.P. 604
 spectrum 158, 853
 speculations 443
 speculative 444
 speed 53
 Speed of a rifle bullet 39
 speed of dark 185
 speed of darkness 186
 Speed of earth 39
 speed of light 347
 speed of light, finite 293
 Speed of lightning 39
 Speed of rain 39
 speed of shadows 186
 Speed of snail 39
 Speed of snow flakes 39
 speed of sound 62, 75, 210
 speed, highest 39
 speed, lowest 36
 speed, perfect 167, 324
 Spence, J. 226
 Sperm 483
 sperm 661
 sperm whales 422
 Spica 124
 Spicer, G. 666
 Spieker, H. 403
 spin 507, 526
 spin 1 particles 371
 spin 2 particles 371
 spin myth 532
 spin valve effect 392
 spin-orbit coupling 262
 spin-spin coupling 262
 spin-statistics theorem 531
 spinor 529
 spinors 133, 846
 Spinoza, B. 756
 Spinoza, Baruch 756, 798
 spirits 647
 spirituality 111, 445
 split personality 110
 spoon 81
 spring 139
 spring tides 94
 sprites 382
 squark 19, 829
 squeezed light 495, 498
 Sreedhar, V.V. 225
 Sriramkumar, L. 606
 stadia 43
 Stalagmite growth 39
 stalagmites 169
 standard apple 819
 standard cyan 366
 standard deviation 165, 819
 standard kilogram 61
 standard model 626
 standard orange 366
 standard yellow 366
 standing wave 139
 stannum 839
 star algebra 854
 star approach 410
 star classes 124, 299
 star speed measurement 173
 star, green 398
 stardust 288
 Stark effect 394
 Stark, Johannes 173
 stars 56, 124, 287, 434
 stars, number of 712
 start of physics 288
 state 107, 408, 537, 557, 797
 state function 554

- state of an mass point,
complete 107
- state of motion 34
- state space diagram 52
- state, physical 34
- statements 413
- states 35, 111
- static friction 105, 106
- static limit 319
- stationary 118, 388
- statistical mechanics 113
- stauon 829
- Stedman, G.E. 220, 229, 825
- Stegeman, George 402
- Steinberg, A. 403
- Steinberg, A.M. 403
- Steiner's parallel axis theorem 68
- stellar black hole 322
- Stephan-Boltzmann constant 646
- steradian 813
- Stern 508
- Stern, O. 516
- Stettbacher, J.K. 473
- Steur, P.P.M. 226
- Stewart, I. 215
- Stewart, Ian 49, 474, 475, 697
- stibium 835
- sticking friction 105
- stigma 804
- Stilwell, G.R. 228
- Stirling's formula 157
- Stodolsky, Leo 229
- Stoehlker, Thomas 606
- stone 194
- Stone, editor, M. 629
- stones 32, 40, 52, 53, 56, 65, 73, 81, 84, 85, 96, 97, 101, 139, 152, 243, 314, 338, 376, 431, 462, 465, 471, 488, 494, 502, 506, 570, 647, 796
- Stoney, Johnstone 347
- Stong, C.L. 219
- Stormer, H.L. 606
- Story, Don 19
- straightness 44, 50, 50, 167
- strain 240
- strange quark 829
- Strauch, F. 405
- Straumann, N. 333
- stretch factor 178
- string theory 715
- Strominger, A. 757
- strong field effects 326
- strontium 839
- structure constants 613
- Styer, D. 403
- Su, B. 605
- Su, Y. 223, 330
- subalgebra 854
- subgroup 129
- Subitzky, Edward 659
- subjects 425
- subscripts 806
- Suchocki, John 214
- Sudarshan, E.C. 230
- Sudarshan, E.C.G. 230
- Sugamoto, A. 666
- sugar 367, 394
- Sugiyama, S. 219
- sulfuric acid 394
- Sullivan, John 663
- Sulalloway, Frank J. 444
- sulphur 839
- sum of parts 454
- sun 21, 65, 100, 125, 287
- Sun 300
- sun 407
- sun dogs 402
- sun will indeed rise tomorrow 89
- sun's heat emission 407
- sun's luminosity 407
- sun's motion around galaxy 281
- Sundaram, B. 605
- sundials 41
- sunflower 434
- superconductivity 391
- superconductors 393
- superfluid 140, 573
- superfluidity 585
- supergiants 125
- superlubrification 105
- superluminal 375
- superluminal motion 186
- superluminal speed 303
- supermarket 43
- supermassive black holes 322
- supernatural phenomena 454
- supernova 410
- supernovae 80, 282, 286
- supernumerary rainbows 362
- superposition 361
- superposition, coherent 538
- superposition, incoherent 539
- superradiation 395
- superstition 444
- supersymmetry 636, 685
- surprise, divine 468
- Surdin, Vladimir 19, 404
- surface 44, 663
- surface tension 106
- surprises 110, 136
- surprises in nature 409
- surreal 435
- surreal numbers 475
- surreals 850, 850
- Susskind, L. 720, 756
- Susskind, Leonard 735
- Sussman, G.J. 223
- Sussman, Gerald 100
- Suzuki, M. 698
- Svozil, K. 606
- SW 365
- Swackhamer, G. 224
- Swagten, Henk 406
- Swenson, C.A. 226
- swimming 661
- Swinney 160
- Swinney, H.L. 227
- swiss cheese 140
- switchable magnetism 392
- switchable mirror 395
- switching off the lights 376
- swords in science fiction 511
- symbol, mathematical 450
- symbols 423, 801
- symmetric 126
- symmetries 452
- symmetry 129, 743
- symmetry of the whole Lagrangian 134
- symmetry operations 129
- symmetry, event 689
- symmetry, external 128, 637
- synapses 422

- synchrotrons 329
 Synge, J.L. 230
 syntactic 425
 system 415, 537, 544
 system, isolated 155
 system, macroscopic 484
 systematic errors 819
 systems, conservative 88
 systems, dissipative 106
 systems, simple 163
 Système International d'Unités (SI) 811
 Suszkwicz, E. 335
- T**
- T-duality 743
 T. Whittaker, Edmund 403
 tables 390
 Tabor, D. 224
 tachyon 187, 187, 194
 tachyons 194, 212, 485
 takes time 724
 Talleyrand 86
 Tanaka, K. 697
 Tantalos 837
 tantalum 831, 839, 841
 Tarantula Nebula 280
 Tarski 141
 Tarski, Alfred 49, 477
 tau 828
 tau neutrino 828
 Tauber, G.E. 405
 Taurus 98
 tax collection 811
 Taylor, B.N. 825, 828
 Taylor, Edwin F. 228, 230, 231, 331
 Taylor, G.J. 222
 Taylor, J.H. 332, 818
 Taylor, J.M. Weisberg, J.H. 332
 Taylor, John R. 401, 825
 Taylor, Joseph 257
 TbCl₃ 395
 teapot 658
 tear shape 106
 technetium 839
 technology 807
 tectonics 221
 Ted Jacobson 752
 Teeter Dobbs, Betty Jo 216
 teeth 159
 Tegelaar, Paul 18
 Tegmark, M. 602, 604
 telecommunication 398
 telekinesis 125
 telephone speed 39
 teleportation 64, 189, 548
 television 32, 175, 339, 395
 tellurium 839
 temperature 146
 temperature scale 226
 temperature, lowest in universe 147
 tensor of curvature 264
 tensor, energy-momentum 358
 tensors 134
 terbium 839
 Terletsii, Y.P. 403
 terms 423
 terrestrial dynamical time 246
 tesla 812
 test 467
 testicle 218
 testimony 218
 tetrahedron 69
 Thaler, Jon 19
 Thales of Miletus 339, 787
 thallium 839
 Thames 168
 theoretical high energy physics 859
 theoretical nuclear physics 859
 theoretical physicists 442
 theoreticians 442
 theories 444
 theory 464
 theory of everything 413, 792
 theory of motion 413
 theory of relativity 171
 theory, experiments and philosophy 859
 theory, physical 446, 637
 thermal de Broglie wavelength 543
 thermal emission 392
 thermal equilibrium 399
 thermal light sources 496
 thermal radiation 391, 396, 397, 398
 thermodynamic degree of freedom 149
 thermodynamic equilibrium 315
 thermodynamic limit 683
 thermodynamics 148
 thermodynamics, first principle 148
 thermodynamics, zeroth principle 146
 thermoelectric effects 391
 thermoluminescence 395
 thermomagnetic effects 393
 thermometer 592
 thermometry 226
 thermostatics 148
 theses 443
 Thidé, Bo 354
 Thierry, Paul 472
 Thirring effect 250
 Thirring, H. 331
 Thirring, Joseph 250
 Thirring-Lense 317
 Thirring-Lense effect 250, 262
 this 28
 Thocharian 218
 Thomas precession 188, 262
 Thomas, Llewellyn 188
 Thompson, R.C. 230
 Thomson effect 391
 Thomson, William 66, 148, 341
 Thor 839
 thorium 839
 thorn 803, 803, 810
 Thorndike, E.M. 228
 Thorne, J.A. Wheeler, K.S. 695
 Thorne, K.S. 331, 757
 Thorne, Kip 231, 329
 Thorne, Kip S. 809
 three-body problem 585
 thriller 119
 throw 32
 throwing, importance of 32
 thulium 839
 Thurston, William P. 663
 tidal effects 237, 266, 278
 tides 73, 90, 93, 220, 329
 tides and friction 94
 Tillich, Paul 700

- time *34, 40, 111, 165, 181, 671, 797*
 time average *569*
 time delay *326*
 time does not exist *703*
 time independence of G *326*
 time intervals *42*
 time is deduced by comparing motions *40*
 time is what we read from a clock *41*
 time machine *182*
 Time magazine *238*
 time translation *135*
 time travel *79, 485*
 time travel to the future *182*
 time, absolute *42*
 time, arrow of *43*
 time, beginning of *702*
 time, definition of *136*
 time, flow of *43*
 time, proper, end of *679*
 timelike *181, 197*
 timelike convention *196*
 tin *839*
 Tipler, Frank J. *476, 655*
 titanium *839*
 Titius, Johann Daniel *100*
 Tittel, Wolfgang *516*
 TNT *651*
 TOE *413*
 tog *154*
 tokamak *147*
 Tolman, Richard *334*
 Tolman, Richard C. *400*
 TOM *413*
 Tomonaga *448, 612*
 Tomonaga Shin-Itiro *578*
 Tomonaga, S. *630*
 tongue *562*
 tonne, or ton *813*
 tooth brush *323*
 toothbrush *170*
 top quark *829*
 topological space *680*
 topological structures *432*
 topological term *621*
 topology *45, 377*
 Topper, D. *222*
 Torge, Wolfgang *218*
 torque *68, 253, 349*
 Torre *271*
 Torre, A.C. de la *401*
 Torrence, R. *335*
 Torricelli, Evangelista *458*
 torsion *327*
 Toschek, P.E. *225, 405*
 total *67, 819*
 total energy *88*
 total momentum *61*
 total symmetry *744*
 total uncertainty *819*
 touch *59*
 touch sensors *562*
 touching *737*
 tourmaline *394*
 Townsend, P.K. *696*
 toys, physical *861*
 trace *539*
 trains *234*
 trajectory *52*
 Tran Thanh Van ed., J. *629*
 transfinite numbers *850*
 transformation *462*
 transformation relations *408*
 transformations *29, 129*
 transforms *65*
 transition radiation *395*
 translation *202*
 translation invariance *42, 45*
 transparency *394*
 transport *29*
 transport of energy *376*
 transubstantiation *142*
 Travis, J. *401*
 Treder, H.-J. *720*
 tree *194, 209, 234, 434, 819*
 Tree growth *39*
 tree, family *35*
 trees *142*
 trees appear *287*
 Trefethen, L.M. *220*
 triboelectricity *391*
 triboluminescence *395*
 triboscopes *106*
 tripod *104*
 trivial knot *663*
 Trojan asteroids *92*
 Trout, Kilgore *303*
 Trower, W.P. *400*
 true *131, 443, 445*
 true velocity of light *375*
 Truesdell, C. *226*
 Truesdell, Clifford *37*
 Truesdell, Clifford A. *216*
 Tsai, W.Y. *400*
 Tschichold, Jan *605, 809*
 Tsuboi, Chuji *218*
 Tsui, D.C. *606*
 Tucholski, Kurt *127*
 tumbleweed *58*
 tungsten *584, 839*
 tunnel *186*
 tunnelling effect *487*
 tunnelling rate *645*
 Tuppen, Lawrence *19*
 turbulence *163*
 Turing machines *715*
 Turner, M.S. *221, 334*
 Twain, Mark *71, 443, 449, 468*
 Twamley, J. *535*
 tweezers, optical *370*
 twin paradox *183*
 Twiss, R.Q. *496, 515*
 two-body problem *585*
 two-squares theorem *843*
 Tyler Bonner, J. *225*

U
 U-duality *743*
 Udem, Th. *401, 841*
 Ueberholz, B. *405*
 UFO *446*
 Uguzzoni, Arnaldo *19*
 UHF *365*
 Ulfbeck, Ole *254, 331*
 Ullman, Berthold Louis *809*
 ultrasound *388*
 ultrasound motor *104*
 ultraviolet *366*
 ultraviolet rays *167*
 Umbanhowar *160*
 Umbanhowar, P.B. *227*
 Umbrellas *168*
 unboundedness *42, 45, 133*
 unboundedness, openness *38*
 unbroken wholeness *715*
 uncertainty relations *484*
 uncountability *430*
 understand *310*

- undisturbed motion *167*
 unification *466, 627*
 uniqueness *42, 45*
 unit *154, 449, 811, 845*
 unit systems *345*
 unitarity *552, 555*
 unitary *131*
 unitary vector space *852*
 units *45*
 units, non-SI *813*
 unity *746*
 universal *444*
 universal 'law' of gravitation *84*
 universal 'law' of gravity *85*
 universal gravity, deviation from *295*
 universal semantic primitives *425*
 universal time coordinate *40, 246, 818*
 universals *424*
 universe *21, 35, 108, 307, 307, 414, 585, 718*
 universe is comprehensible *460*
 universe not a physical system *716*
 universe not a set *715*
 universe recollapse *410*
 universe, age of *195, 701*
 universe, believer *284*
 universe, energy of *304*
 universe, essence *717*
 universe, existence of *461*
 universe, filled with water or air *296*
 universe, only one *454*
 universe, oscillating *701*
 universe, size of *708*
 universe, total *284*
 universe, visible *284*
 universe, volume of *709*
 universes, other *444*
 unnatural phenomena *454*
 unpredictable *109*
 Unruh radiation *688*
 Unruh, R.M. Wald, W.G. *607*
 Unruh, W. *757*
 Unruh, W.G. *330, 608, 697, 698*
 Unruh, William *233, 592, 593*
 Unruh, William G. *607*
 unstoppable motion, i.e. light *172*
 ununbium *839*
 ununhexium *839*
 ununnilium *839*
 ununoctium *839*
 ununpentium *839*
 ununquadium *839*
 ununseptium *839*
 ununtrium *839*
 unununium *839*
 Unwin, S.C. *230*
 up quark *829*
 uranium *839*
 Uranos *839*
 Urban et al., M. *629*
 urban legends *368*
 Urban, M. *629*
 URL *860*
 usage of electricity *288*
 usenet *859*
 UTC *40, 246*
 UVA *366*
 UVB *366*
 UVC *367*
V
 vacuum *203, 311, 377, 520, 592*
 vacuum curvature *269*
 vacuum energy density *653, 727*
 vacuum polarisation *583*
 vacuum polarization *510*
 vacuum state *524*
 Vacuum wave resistance *821*
 vacuum, hand in *329*
 vacuum, unstable *410*
 Vafa, C. *757*
 Valanja, P. *403*
 Valentin, Karl *565*
 Valsiner, Jaan *473*
 Valsinger, Jaan *473*
 value *432*
 value of mass *306*
 vampire *376*
 van Bladel, J. *228*
 van der Mark, Martin *18*
 van der Zouw, G. *516*
 Van Helden, A. *222*
 van Houten, H. *604*
 van Tiggelen, Bart *406*
 van Wijk, Mike *18*
 Vanadis *840*
 vanadium *840*
 Vancea, I.V. *720*
 Vanier, J. *824*
 vanishing *263, 539*
 Vannoni, Paul *19*
 Van Dam, H. *401, 696, 720*
 Vardi, Ilan *535*
 variable *32, 34, 450*
 variation *34*
 variational principle *118*
 vector *55, 133, 845, 851*
 vector part of a quaternion *844*
 vector potential, magnetic *354*
 vector product *68, 850*
 vector space *55, 851*
 vector space, Euclidean *852*
 vector space, hermitean *852*
 vector space, unitary *852*
 Veer, Rene Van der *473*
 Veer, René Van der *473*
 Vega *124*
 Vela satellites *608*
 velars *804*
 velocity *53, 165, 770*
 velocity measurements *203*
 velocity of an electron *374*
 velocity of light, one-way *210*
 velocity of light, two-way *210*
 velocity, faster than light *199*
 velocity, perfect *324*
 velocity, relative *199*
 velocity, relative - undefined *267*
 Veneziano, G. *695, 697*
 Venus *261*
 verb *425*
 Vergilius *249*
 verification *470*
 Vermeil, H. *332*
 Verne, Jules *372*
 vernier *51*
 Vessot *235*
 Vessot, R.F.C. *330*
 Vestergaard Hau, Lene *216*

- VHF 365
Vico, Giambattista 554
video recorder 155
viewpoint independence 127
viewpoints 126
Vigotsky, Lev 417, 473
Villain, J. 607
Vincent, D.E. 222
Virasoro algebra 642, 856
Virgo 98
virtual particles 520
Visser, Matt 608
vitamin B₁₂ 836
vitamin C 523
vitreous 342
Vlaev, S.J. 96, 223
vocabulary 424, 438
void 144, 458
Voigt effect 392
Voit, A. 402
Volin, Leo 19
volitional 30
Volkswagen 264
Vollmer, G. 474
Vollmer, M. 402
volt 812
Voltaire 101, 120, 462, 471, 476, 647, 730, 819
volume 48
volume of the universe 709
voluntary motion 105, 108
von Klitzing constant 646
von Neumann equation 538
von Klitzing, K. 606
vortex in bath tub or sink 220
vortex lines 354
vortex tube 158
vortex, black 319
Vos-Andreae, J. 516
Voss, R.F. 603
Voyager satellites 169
- W**
W 392, 394
W boson 828
Wagon, Steve 49
Wald, George 156
Wald, R. 337
Wald, R.M. 336, 698
Wald, Robert M. 329
Walgraef, Daniel 227
Walker, A.G. 289
Walker, Jearl 28
Walker, R.C. 230
walking 152, 418, 474
walking on two legs 418
walking speed 86
Wallin, I. 228
Wallis, J. 802
Walter, H. 405
Walter, Henrik 224
Wambsganss, J. 334
Wampler, E. Joseph 402
Wang Juntao 472
Wang, L.J. 403
Wang, Z.J. 667
Warkentin, John 19
Washizu, M. 406
water 21, 225, 392, 395, 831
Water density 646
water in universe 296
water taps 163
Watson, A.A. 337
watt 812
wave 361
wave angular momentum 371
wave equation 361
wave function 554
wave impedance/resistance 377
wave interference 575
wave vector 361
wave-particle duality 493
wavefunction, symmetry of 523
wavelength 362
waw 804
weak energy condition 246
weak isospin 620
weak mixing angle 621
Wearden, John 605
weather 21
Webb, R.A. 603
weber 812
Weber, G. 514, 757
Weber, R.L. 163
Weber, T. 607
Weekes, T.C. 629
Wegener, Alfred 76, 221
Wehner, Rüdiger 401
Weib 218
Weierstrass, K. 802
Weierstrass, U. 226
Weigert effect 395
weight 95, 103, 248
weight of the moon 100
Weil, André 802
Weinberg angle 621
Weinberg, Steven 329, 333, 337, 608, 695, 696, 712, 756
Weis, A. 698
Weisberg, J.M. 332
Weisskopf, V.F. 618
Weisskopf, Victor 563
Weisskopf, Viktor 470
Weitz, M. 401, 841
Weitzmann, Chaim 249
Wells, M. 224
Weninger, K. 406
Weninger, K.R. 221
Werner, S.A. 607
Wertheim, Margaret 730
Wesson, Paul 293, 333
West, G.B. 225
Weyl, Hermann 44, 527
whale 99, 563
whale brain size 563
whale nerve cell 831
Wheeler 318
Wheeler, J.A. 335, 602, 695, 757
Wheeler, John 310, 601
Wheeler, John A. 228, 230, 231, 314, 328, 329, 809
Wheeler-DeWitt equation 682
wheels in nature 58
Whewell, William 378
whirl 78
white 397
white colour does not last 153
White, H.E. 227
White, M. 221, 334
Whitehead, Alfred North 451
Whitney, A.R. 230
whole, the 415
Widom, A. 516
Wiegert, Paul A. 223
Wien's colour displacement 'law' 398
Wien, Wilhelm 398

- Wien displacement constant 646
- Wierzbicka, Anna 19, 216, 425, 441
- wife 218
- Wigner 755
- Wigner, E. 535
- Wigner, E.P. 401, 630, 696, 720, 758
- Wigner, Eugene 437, 475, 526
- Wigner, Eugene P. 515
- Wijngarden, R.J. 407
- Wilczek, F. 629, 667
- Wilczek, Frank 616, 784
- Wilde, Oscar 417
- Wilde, Oscar 454
- Wilk, S.R. 405
- Wilkie, Bernard 219
- Wilkinson, S.R. 605
- Will, C. 228, 330, 331, 336
- Willberg, Hans Peter 605
- William Herschel 78
- William of Occam 745
- Williams, David 385
- Williams, David R. 405
- Williams, Earle R. 404
- Williams, R. 329
- Wilson, J.R. 608
- Wilson, Robert 285
- Wilson, Robert W. 333
- wind 168
- window frame 185
- wine 142, 505, 541
- wine bottle 64, 80
- Wineland, D.J. 405
- Wino 829
- Wirbelrohr 158
- Wirtz 284, 285
- Wisdom, J. 223
- wise old man 119, 201
- Wise, N.W. 608, 820
- Witt, Bryce de 604
- Witte, H. 403
- Witteborn, F.C. 400
- Witten, E. 695, 757
- Wittgenstein, Ludwig 20, 26, 32, 34, 43, 56, 79, 108, 111, 156, 413, 423, 426, 437–440, 448, 451, 454, 465, 475
- Wittke, J.P. 516
- Woerdman, J.P. 516
- Wolf, C. 698
- Wolf, Emil 402
- Wolfendale, A.W. 404
- Wolfram 839
- wolframates 395
- Wollaston, William 509
- Wolpert, Lewis 215
- woman 218, 318
- women 90, 175
- Wong, S. 403
- Wood, Bernard 474
- Wootters 525
- Wootters, W.K. 535
- words 423
- words heard 434
- words spoken 434
- work 73, 118
- work, physical 103
- world 26, 35, 414, 795, 797
- world colour survey 403
- World Geodetic System 222
- world of dreams 796
- world question center 862
- world-line 181
- world-wide web 859
- Wouthuysen, S.A. 516
- Wright, Steven 328
- wristwatch time 179, 239
- writing 451
- written texts 288
- wrong 165, 171, 443
- Wu, C. 405
- Wu, T.T. 401
- Wulfilu 806
- Wynands, R. 405
- X**
- X-rays 167, 367, 492
- X-rays, hard 367
- X-rays, soft 367
- xenon 840
- Xu Liangying 472
- Xue, S.-S. 608
- Y**
- Yamamoto, Y. 515
- Yamane, T. 402
- Yandell, Ben H. 720
- Yang, C.N. 401
- Yazdani, A. 404, 517
- year, number of days 94
- yellow 366
- yo-yo 86
- Yoshida, K. 609
- Young, James A. 219
- Young, Thomas 362
- Yourgray, Wolfgang 224
- youth, gaining 244
- ytterbium 840
- yttrium 840
- Yucatan impact 288
- Yukawa 578
- Z**
- Z boson 828
- Z boson mass 646
- Zaccone, Rick 19
- Zakharian, A. 220
- Zalm, Peer 19
- Zander, H.C. 475
- Zanker, J. 216
- Zbinden, H. 516
- Zeeman effect 392
- Zeh, H.D. 602, 698
- Zeh, Hans Dieter 538
- Zeilinger, A. 516, 825
- Zeller, Eduard 476
- Zener effect 394
- zenith angle 84
- Zeno 50, 679, 737
- Zeno of Elea 563
- Zeno of Elea 25, 27, 54
- Zensus, J.A. 230
- Zermelo, Ernst 428
- zero 433, 807
- zero-body problem 585
- Zeus 281
- Zhang 248
- Zhang, Yuan Zhong 228, 229
- Ziegler, G.M. 49
- zigzag shape 382
- Zimmerman 755
- Zimmerman, E.J. 605, 696, 720, 758
- zinc 840
- zino 829
- zippo 162
- zirconium 840

ZnS 395	Zurek 525	Zwerger, W. 603
ZnSb 391	Zurek, W.H. 218, 474, 535, 602	Zwicky, F. 334
zodiac 89	Zurek, Woycek 421	Zwicky, Fritz 301
Zuckerman, G. 857	Zweck, Josef 221, 406	



...
ma la religione di voi è qui
e passa
di generazione in generazione
ammonendo
che SCIENZA È LIBERTÀ.

Giosuè Carducci

Dalla lapide nell'atrio dell'Università di Bologna.*

* '... but the religion of you all is here and passes from generation to generation, admonishing that SCIENCE IS FREEDOM.' From Carducci's text inscribed the entry hall of the University of Bologna, the oldest university of the world.