



ОБЪЕДИНЕННЫЙ
ИНСТИТУТ
ЯДЕРНЫХ
ИССЛЕДОВАНИЙ

Дубна

96-78

E13-96-78

J.Budagov, Y.Kulchitsky¹, A.Lebedev, Yu.Lomakin,
L.Permjakova, V.Romanov, N.Russakovich, A.Shchelchkov,
A.Sissakian, Y.Sorokina, N.Topilin

**ATLAS BARREL HADRON CALORIMETER:
TOOLING DESIGN DESCRIPTION
FOR MODULE ASSEMBLY
(Dubna Variant)**

Submitted to the International ATLAS Calorimeter Meeting,
CERN, Switzerland, 1996

¹On leave from IP Academy of Science, Minsk, Belarus

1996

1 INTRODUCTION

Following the ATLAS TILECAL group decision, a group of designers from the Laboratory Nuclear Problems (LNP) has presented for the ATLAS TILECAL meeting the design of Barrel Module assembly tooling ([1],[2],[3]).

The tooling is designed with a view to it being used as universal equipment at JINR (Russia), ANL (USA) and Barcelona University.

As the Laboratory of Nuclear Problems is a manufacturing organization, the design of the tooling was adapted to the local manufactory technical possibility.

The central idea of the tooling design (and use) that we are oriented on use of the large boring mill with $\varnothing 6$ m rotary table at LNP's machine shop. We consider the rotary table standard equipment set as ASSEMBLY FLOOR and as BASEMENT to plan assembly tooling on.

Besides, building 105 (where there is the boring mill) has sufficient free room and suitable conditions for the assembly and temporary storage of the finished submodules. Building 105 has a crane rated at 70 tons. It provides a possibility of performing the manipulations with the finished modules weighing as much as 20 tons.

2 THE TOOLING DESIGN DESCRIPTION FOR MODULE ASSEMBLY

The tooling for the module assembly consists of a base, left and right face brackets, two horizontal platforms with rails, six columns and 38 adjustable supports.

The leading idea of JINR's assembly procedure is that the rotary table of the Czech boring mill is used as the base for the tooling. The diameter of the rotary table is 6 meters, but its length required for installing the tooling is 7.55 m. Therefore two beams with overall dimensions $440 \times 500 \times 3500$ mm³ of each beam are mounted along the diameter of the rotary table. The beams are mounted with a gap of 550 mm. The beams are ready-made and are part of the standard set of the boring mill.

Since the beams are narrower, than the module, ten transverse plates with clamps for the girder are established on the beams. The plates dimensions are $50 \times 60 \times 600$ mm³. Each of these plates has two supports 58 mm in height. The girder is mounted on these supports. Two of these supports are wider than the others and are on one side of the of the longitudinal symmetry axis of the tooling; they serve for centering the girder with respect to the longitudinal axis. During assembling the girder must be fixed on the supports.

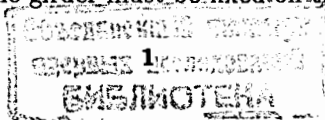

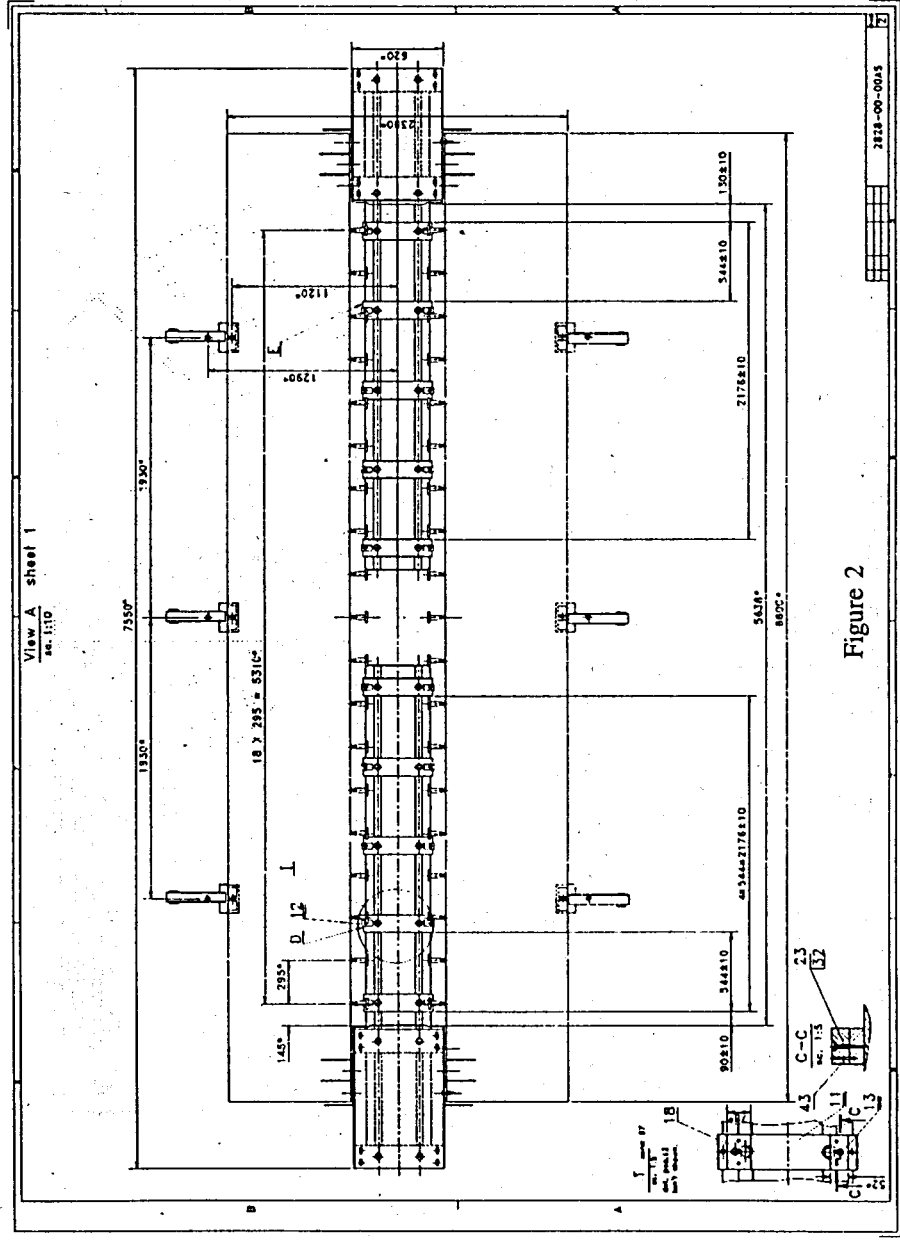
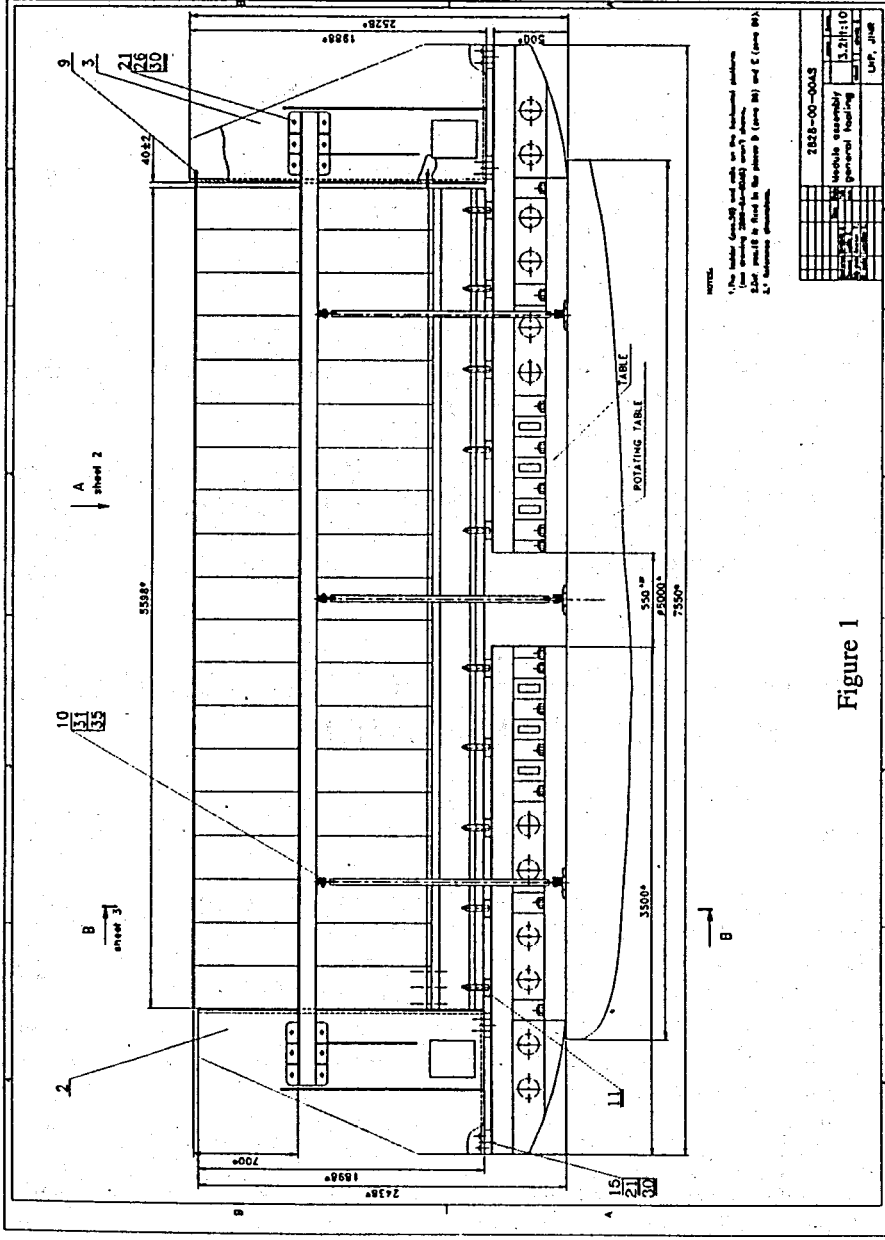

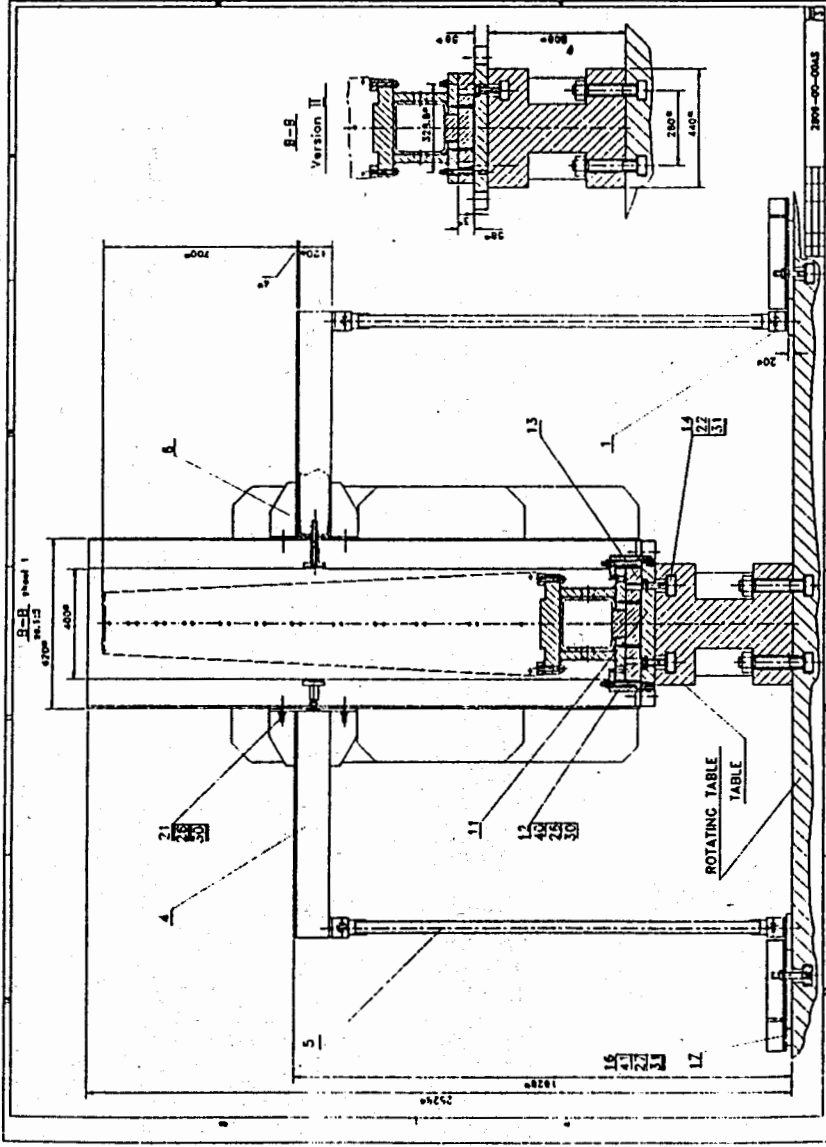

Figure 3

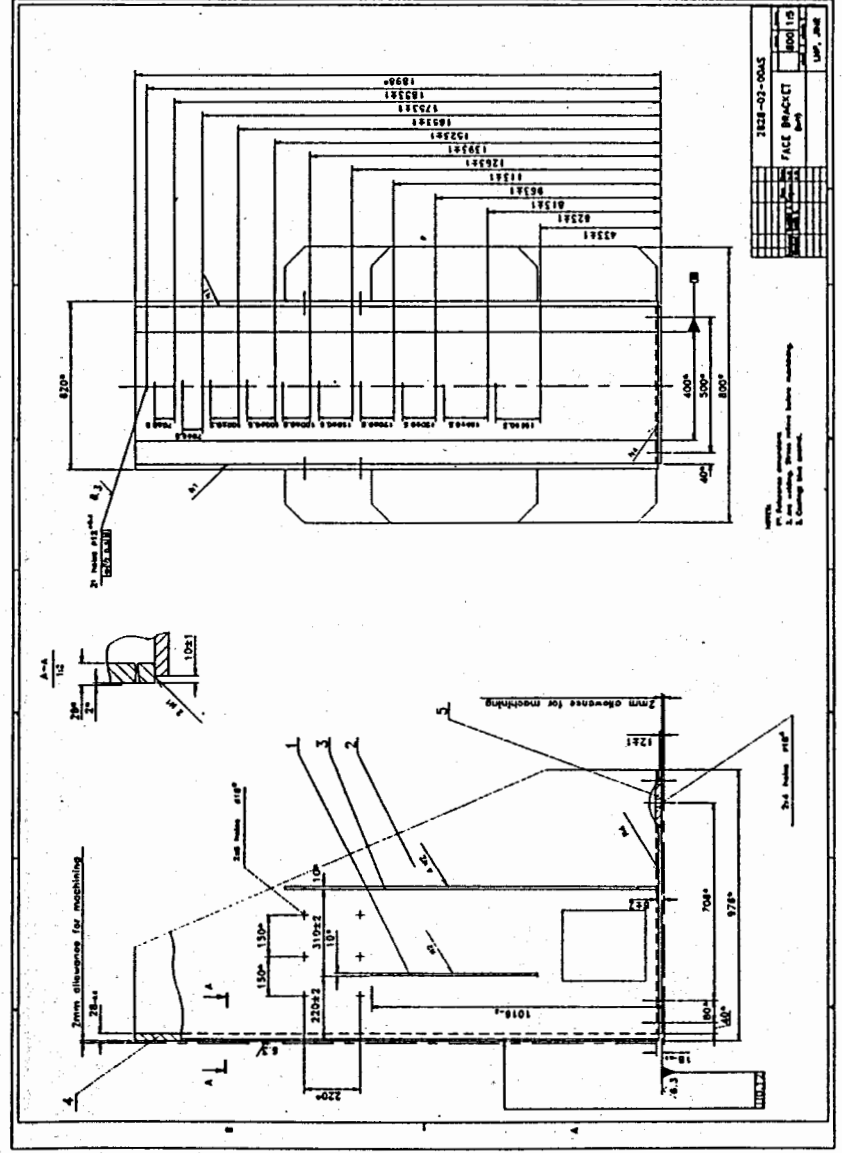

Figure 4

References

- [1] J. Budagov, Y. Kulchitsky, A. Lebedev et al., ATLAS Barrel Hadron Calorimeter Module Design, JINR preprint E13-95-20, JINR, Dubna, 1995.
- [2] J. Budagov, Y. Kulchitsky, A. Lebedev et al., ATLAS Barrel Hadron Calorimeter: Assembling Device and Module Assembling Technology Design Description, JINR preprint E13-95-254, JINR, Dubna, 1995.
- [3] J. Budagov, Y. Kulchitsky, A. Lebedev et al., ATLAS Barrel Hadron Calorimeter: Module Assembly and Tooling Design Description, ATLAS internal note, TILE-CAL-NO 52, CERN, Geneva, 1995.

Received by Publishing Department
on March 3, 1996.

Будагов Ю.А. и др. E13-96-78
Адронный калориметр установки ATLAS:
описание конструкции приспособления для сборки модуля

Представлено детальное описание конструкции приспособления для сборки модуля барреля адронного калориметра установки ATLAS.

Так как организатором работ по изготовлению этого приспособления является Лаборатория ядерных проблем ОИЯИ, то в процессе разработки нами были учтены наши производственные возможности. В частности, при конструировании приспособления мы ориентировались на использование большого карусельного станка с планшайбой диаметром 6 м в качестве фундамента и основания для его монтажа.

Работа выполнена в Лаборатории ядерных проблем ОИЯИ.

Препринт Объединенного института ядерных исследований, Дубна, 1996

Budagov J. et al. E13-96-78
ATLAS Barrel Hadron Calorimeter:
Tooling Design Description for Module Assembly (Dubna Variant)

The detailed description of the tooling design for ATLAS barrel hadron module assembly is presented.

As the Laboratory of Nuclear Problems is a manufacturing organization, the design of the tooling was adapted to the local manufactory technical possibility. Designing the tooling we are oriented on use of the large boring mill with \varnothing 6m rotary table at LNP's machine shop as ASSEMBLY FLOOR and as BASEMENT for the tooling assembly.

The investigation has been performed at the Laboratory of Nuclear Problems, JINR.

Preprint of the Joint Institute for Nuclear Research, Dubna, 1996