

**ОБЪЕДИНЕННЫЙ  
ИНСТИТУТ  
ЯДЕРНЫХ  
ИССЛЕДОВАНИЙ  
ДУБНА**

**E10-88-28**

**N.M.Nikityuk**

**THE METHOD OF SYNDROME CODING  
AND ITS APPLICATION  
FOR DATA COMPRESSION  
AND PROCESSING IN HIGH ENERGY  
PHYSICS EXPERIMENTS**

Submitted to the I International Joint Conference  
of ISSAC-88 and AAECC-6, Roma, July, 1988.

**1988**

## 2. SYSTEM OF ANALOGIES

To make the best use of coding theory and practice, the author has suggested a system of analogies for coding theory and the theory of multichannel hodoscopic systems<sup>1,2,3</sup> (see Table)

### 1. PROBLEM

A great number of multichannel position-sensitive detectors is used in high energy physics experiments. There is a small number (10-20%) of signals for processing with the aid of electronics and special-purpose processors. The processing of physics information is hierarchical in nature. If it is considered in time, the time of the first level is 100 ns when background information is filtered according to the selection criteria of useful events. The particle multiplicity is the main selection criterion for useful events registered in a coordinate detector. The second criterion is to determine the interaction coordinates of particle with sources in the usual binary code for a minimum time.

Figure 1 presents a simple scheme containing a target T and a detector. The detector consists of 3l sources (for example, scintillators). Two particles interact with the scintillators which generate two signals simultaneously. After amplifying and shaping, the signals are supplied to the inputs of a majority coincidence circuit and an encoder (Fig.2). Sometimes several neighbouring scintillators (cluster events) generate from one particle. In this case there arises the problem of cluster registration and identification. The multiplicity of particles is determined with the aid of the majority coincidence circuit. The interaction coordinates  $X_1$  and  $X_2$  are measured by means of the parallel encoder.

If we know wittingly that  $t=1$ , the construction of an encoder based on combination circuits presents no difficulties. To solve the problem at  $t > 1$ , shift registers and priority encoders are commonly used. Synchronization pulses are required for the operation of these circuits. This means that very much time and a large number of circuits are needed for a great variety of registration channels. Modern PROMs have a limited number of address inputs, and so they cannot solve this problem. The use of correcting code theory and practice helps to answer the following question: "How is a parallel encoder constructed for  $t > 1$ "<sup>1,2</sup>.

Table

Coding theory 1	Theory of hodoscopic systems 2
1.Code vector of the block codes having $n$ symbols, $K = n - tm$ information symbols.	Word read out from $n$ position-sensitive sources
2.Mistake vector $e$	Physical events
3.Cluster of mistakes	The number of position-sensitive sources $t$ operated in the detector simultaneously
4.The number of parity check fits $N = mt$	The number of digits, $N$ , at the outputs of the parallel encoder
5.Code efficiency $V = k/n$	Compression coefficient, $K_c = n/N$
6.Coding device	Encoder
7.Parity check matrix $H^T$	Connection matrix $H$
8.Coding distance $d$	Coding distance $d$
9.Weight of the code word, $W$	Row weight of the connection matrix, $W$
10.Column weight parity check matrix, $b$	Branching coefficient for a signal from a sensitive source, $b$
11.Two-dimensional iterative code	Data coding in a two-dimensional hodoscope
12.Completely asymmetric channel	Multichannel data transmission system

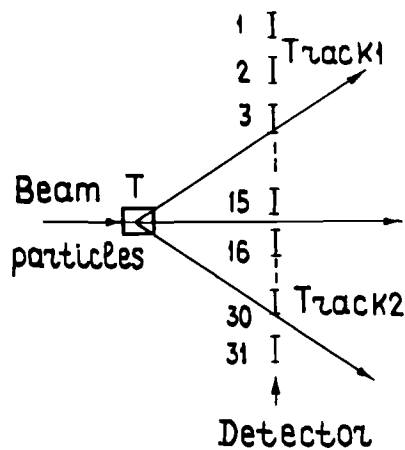

Fig. 1. Simple diagram for the registration of two particles by the scintillation hodoscope. T-target, 1-31-scintillators.

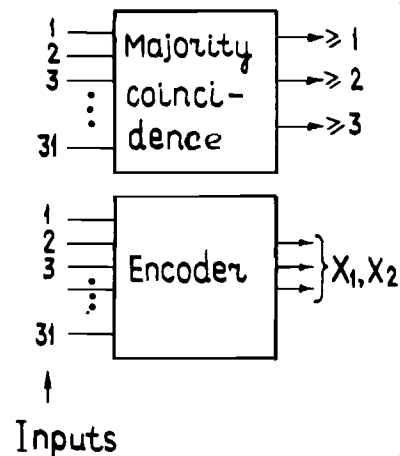

Fig. 2. Block-diagram for fast event selection.

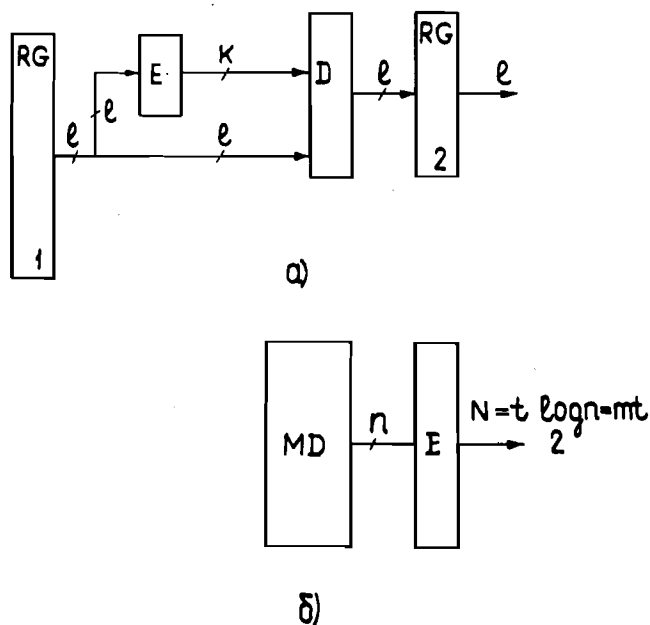

Fig. 3. Explanation of the Syndrome Coding Method. a) Conventional multichannel system where the correcting code is used. E -encoder, D -decoder, MD -detector. b) System of data registration where the method of syndrome coding is used.

### 3. SYNDROME METHOD

The essence of the method is the following [1,2,4,6]. As assumed in coding technique, let us consider a typical multi-channel data transmission system (Fig. 3a). There is a  $l$ -bit register on the transmitting side. A  $K$ -bit syndrome is added to the  $l$ -bit register according to a given rule. The  $l+K$ -bit word is transmitted to a receiver. Encoding is carried out by the encoder. If there are mistakes during the transmission, the decoder finds and corrects them using the syndrome.

Now let us consider a simpler transmission scheme (Fig. 3b). Assume that the transmitted  $n$ -bit word is always zero. Then ones occurring when the sources operate are considered as an error vector of the code word. For example, the 31-bit zero word 000.....000 is transmitted, and on the receiver side we get the following word:

00000000010000000000 01000000000

This means that there are mistakes in positions 10 and 22 if the count of the positions is carried out from left to right. Further, if the BCH code correcting two mistakes is chosen, the number of bits at the encoder outputs is

$$N = 2 \log_2 31 \approx 10.$$

In other words, we have the effect of compression from a 31-bit unitary position code to a 10-bit cyclic code. In this case the compression effect grows with increasing the number  $n$ . As a result, it is possible to use PROMs for solving the problem by the arithmetic method.

It should be stressed that one circumstance is important: according to theory, the syndrome carries information of the multiplicity and coordinates.

### 4. APPLICATION OF THE SYNDROME METHOD

This method is used to construct fast electronic units for the selection of events and special-purpose processors in nuclear physics experiments. Let us consider several examples.

1. Use of the algebraic theory of correcting codes. Assume that there is a position-sensitive detector containing  $n = 31$  sources, and it is necessary to determine the multiplicity ( $t \leq 2$ ) and coordinates of particle interaction. To draw a principal diagram of the parallel encoder, the matrix  $H^T$

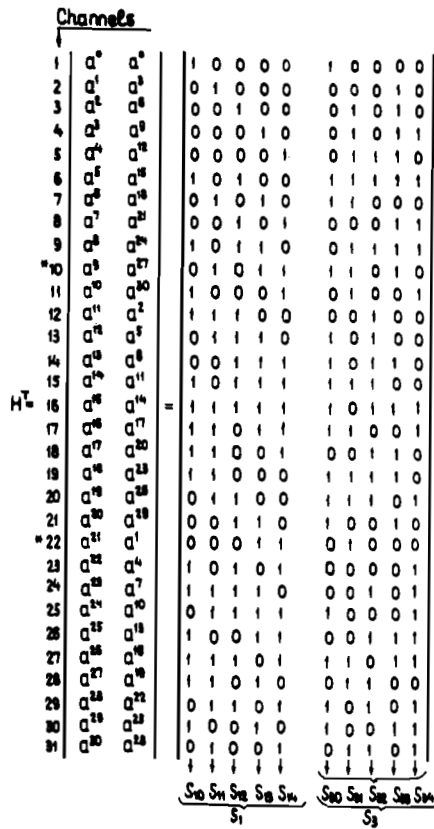

Fig. 4. BCH-code parity check matrix for the correction of two mistakes (or for the registration of two events).

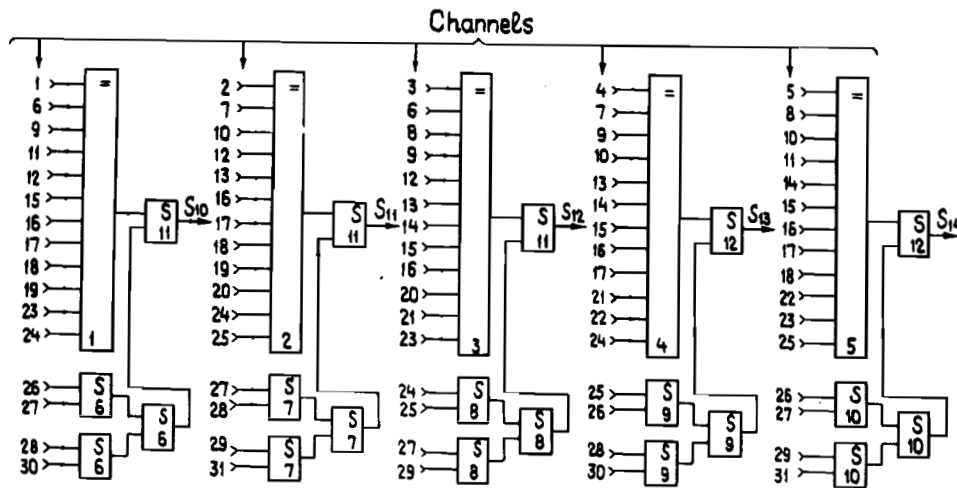

Fig. 5. Principal scheme used to calculate the syndrome  $S_1$ .

(connection matrix) should be constructed. The syndrome code is calculated with the aid of this matrix.

The elements of the Galois field  $GF(2^5)$  generated by an irreducible polynomial  $x^5+x^2+1$  are presented on the right of Fig. 4. Figure 5 shows a principal scheme used to calculate the syndrome  $S_1$ . The numbers of the channels (position-sensitive sources), which logic pulses are sent from, are denoted by numerals. For  $n=31$  and  $t=2$  there is a 10-bit cyclic code at the outputs of the encoder. This code carries information on the multiplicity and interaction coordinates of two particles. As it follows from the known theorem<sup>6,8</sup>, for finding  $t$  it is necessary to analyse the following determinants:

$$\det L_1 = S_1 \quad \text{and} \quad \det L_2 = S_1^3 + S_3.$$

In addition, we introduce some other signs EVEN and ODD. These signs are obtained very simply if all outputs of the detector after amplifying and shaping are connected to the inputs of the parallel parity checker. Then we have the following algorithm for event selection. If  $S_1 \neq 0$ , there is at least one signal at the outputs of the detector. If  $\det L_1 \neq 0$ ,  $\det L_2 = S_1^3 + S_3 = 0$  and there is a sign ODD, then  $t=1$ . For  $\det L_1 \neq 0$ ,  $\det L_2 \neq 0$  and a sign EVEN,  $t=2$ . If  $\det L_1 \neq 0$ ,  $\det L_2 \neq 0$  and there is a sign ODD, then  $t \geq 3$ . So, in our example  $S_1 = a^9$  and  $S_3 = a^{27}$ . Then  $S_1 + S_3^3 = a^{(9)^3} + a^{27} = 0$  (mode 2). But for  $t=2$ ,  $S_1 = a^9$ ,  $S_3 = a^{21}$  and  $\det L_2 \neq 0$ . Using the parallel methods of calculation in the Galois field  $GF(2^4)$  and fast ECL-microcircuits, the following parameters for special-purpose processors have been obtained<sup>7</sup>: at  $n=15$  the solution time for  $t=1$ ,  $t=2$ ,  $t=3$  and also for the determination of three interaction coordinates  $X_1$ ,  $X_2$ , and  $X_3$  does not exceed 40 ns.

Figure 6 presents a scheme of the processor which can execute three functions: a majority coincidence circuit, a parallel counter and a processor for calculation of three event coordinates  $X_1$ ,  $X_2$  and  $X_3$ . Since  $t \leq 3$ , according to the theory of BCH-code decoding, which corrects three mistakes, the processor analyses the following determinants:

$$\det L_1 = S_1, \quad \det L_2 = S_1^3 + S_3$$

and

$$\det L_3 = S_1^6 + S_1^3 S_3 + S_3^2 + S_1 S_5.$$

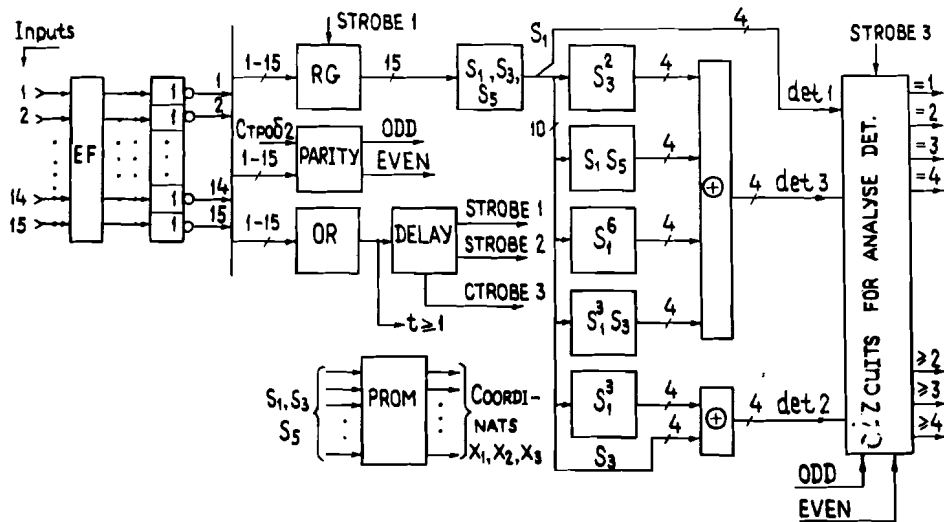

Fig. 6. Scheme of the majority coincidence circuit and of the special-purpose processor with algebraic structure. EF-emitter followers, T-delay, RG-register.

For a fast solution of such determinants, parallel algorithms are used for calculation in the Galois field  $GF(2^m)^{14/}$ . The coordinates are calculated with the help of PROMS <sup>17/</sup>.

2. Superimposed codes <sup>3,9,10-12/</sup>. It is convenient to use these in light coding systems and when signals have a small amplitude (analog signals). It is important that light and electronic amplifiers-mixers can be used to calculate the syndrome. However,  $K_c$  of such codes is smaller than for BCH-codes since coding words are added not by modulo-2 but by the Boolean sum rules. Superimposed codes having a constant weight are used for data compression in scintillation hodoscopes and for the creation of majority coincidence circuits and parallel counters. Two coding schemes are presented in Fig. 7. The first scheme is used at CERN, and the other is suggested by the author. It is obvious that the number of registration channels in the second scheme is smaller at other equal parameters. And its economical efficiency rises as  $C_N^2/2N$ . Optical fibers can be also used for coding (Fig. 8). The selection of events is performed as follows <sup>11,12/</sup>. If the weight of the syndrome code at the outputs is 2,  $t$  is always equal to 1. If the weight is equal to 3 or 4 and three is a sign EVEN, then  $t=2$  or 4 and so on. The Hamming codes and the Gray code are shown to be superimposed ones <sup>3,10,15/</sup>.

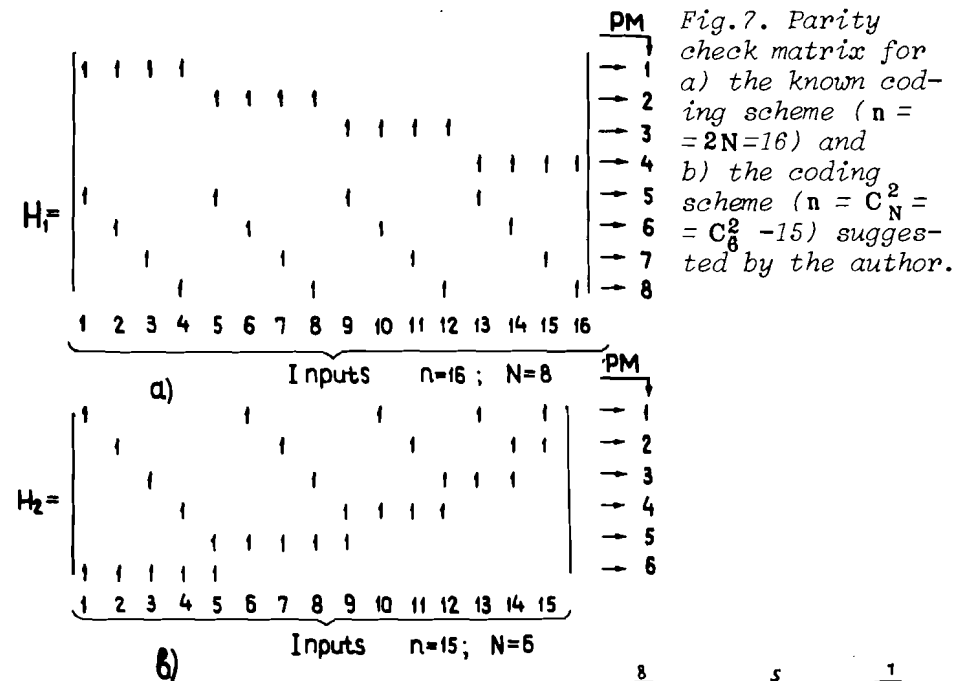

Fig. 7. Parity check matrix for a) the known coding scheme ( $n = 2N = 16$ ) and b) the coding scheme ( $n = C_N^2 = C_8^2 = 15$ ) suggested by the author.

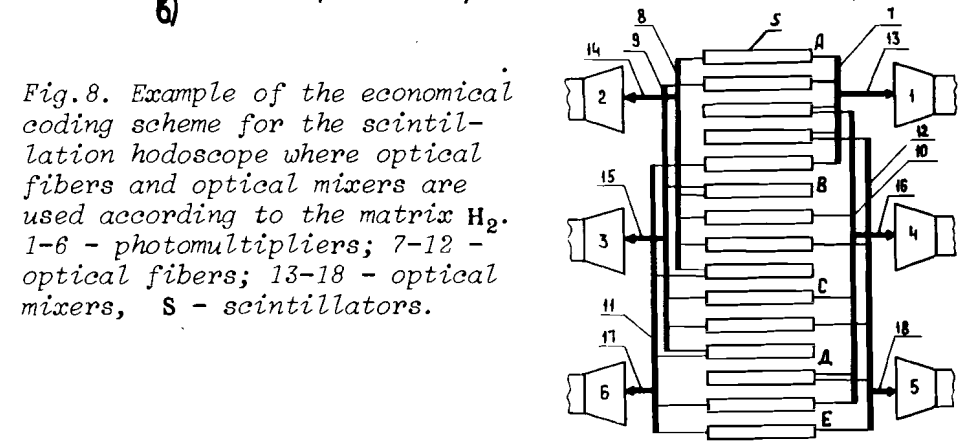

Fig. 8. Example of the economical coding scheme for the scintillation hodoscope where optical fibers and optical mixers are used according to the matrix  $H_2$ . 1-6 - photomultipliers; 7-12 - optical fibers; 13-18 - optical mixers, S - scintillators.

3. Use of iteration codes. This class of codes is very wide. Iteration codes are extensively used for a large number of registration channels ( $t > 100$ ) and in studies of complicated topologies of events with clusters.

Let us consider some examples. Figure 9 shows a complicated event registered in the detector. The detector is composed of 1296 position sensitive sources presented as a matrix comprising 36 rows and 36 columns. The syndrome of this code has 128 bits, and the code efficiency grows with increa-

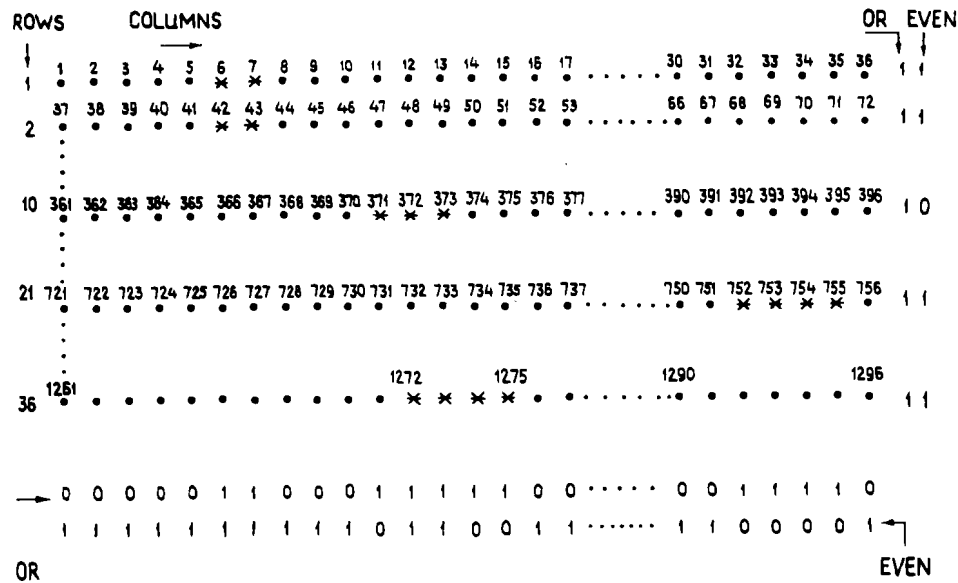

Fig.9. Example of using the iteration code OR-PARITY for complicated event registration. The events are marked by •.

sing the number n. So,  $K_c = 1296/128 \approx 10$  for  $n = 1296$  and  $K_c = 4096/256 \approx 16$  for  $n = 4096$ . A short algorithm for event recognition given in the figure consists in the following. The coincidence of signals EVEN and OR in rows 1 and 2 in column 6 indicates unambiguously that pulses are supplied from sources 6, 7, 42 and 43. The signals coming from sources 752-755, etc., are also registered unambiguously. It should be emphasized that any codes, e.g. superimposed codes, can be taken for iteration.

4. Application of the abundant Gray code for increasing the space resolution of a scintillation hodoscope<sup>15/7</sup>. In accordance with the table of analogies, we can present a coding scheme of the scintillation hodoscope containing  $n = 15$  scintillators and  $N = 4$  photomultipliers in the form of a Hemming code parity check matrix:

$$H_3 = \begin{pmatrix} 1 & 0 & 1 & 0 & 1 & 0 & 1 & 0 & 1 & 0 & 1 & 0 & 1 & 0 & 1 \\ 0 & 1 & 1 & 0 & 0 & 1 & 1 & 0 & 0 & 1 & 1 & 0 & 0 & 1 & 1 \\ 0 & 0 & 0 & 1 & 1 & 1 & 1 & 0 & 0 & 0 & 0 & 1 & 1 & 1 & 1 \\ 0 & 0 & 0 & 0 & 0 & 0 & 0 & 1 & 1 & 1 & 1 & 1 & 1 & 1 & 1 \end{pmatrix} \begin{matrix} N_1 \\ N_2 \\ N_3 \\ N_4 \\ \text{Outputs} \end{matrix}$$

Inputs →

If we add columns 6 and 7 or 13 and 14 by the Boolean sum rules in the matrix  $H_3$ , we get a similar result 1111. In practice, this means that using such a coding scheme, it is impossible to register the coordinates of double clusters because the Hemming code can correct only one mistake. Rearranging the columns of the matrix  $H_3$ , we obtain 15 words of the Gray code presented as a matrix  $H_4$ .

$$H_4 = \begin{pmatrix} 1 & 1 & 0 & 0 & 1 & 1 & 0 & 0 & 1 & 1 & 0 & 0 & 1 & 1 & 0 \\ 0 & 1 & 1 & 1 & 1 & 0 & 0 & 0 & 0 & 1 & 1 & 1 & 1 & 0 & 0 \\ 0 & 0 & 0 & 1 & 1 & 1 & 1 & 1 & 1 & 1 & 1 & 0 & 0 & 0 & 0 \\ 0 & 0 & 0 & 0 & 0 & 0 & 0 & 1 & 1 & 1 & 1 & 1 & 1 & 1 & 1 \end{pmatrix} \begin{matrix} N_1 \\ N_2 \\ N_3 \\ N_4 \\ \text{Outputs} \end{matrix}$$

Inputs →

The scintillator is put according to each column of the matrix  $H_4$  and the photomultiplier according to each row. It is not difficult to check that such Boolean sums as  $n_1 \vee n_2$  and  $n_2 \vee n_3$ ,  $n_4 \vee n_5$  and  $n_5 \vee n_6$ ,  $n_9 \vee n_{10}$  and  $n_{10} \vee n_{11}$  are coincident in the matrix  $H_4$ . This factor leads to decreasing the space resolution of the double cluster coordinates in these positions. To solve such uncertainties, additional bits to the classical Gray code have been suggested by the author. These bits are arranged in definite positions:

$$1 \ 0 \ 0 \ 1 \ 0 \ 0 \ 0 \ 0 \ 1 \ 0 \ 0 \ 1 \ 0 \ 0 \ 0$$

If one needs to register the coordinates of triple clusters, it is necessary to add abundant bits

$$H_4 = \begin{pmatrix} 1 & 1 & 0 & 0 & 1 & 1 & 0 & 0 & 1 & 1 & 0 & 0 & 1 & 1 & 0 \\ 0 & 1 & 1 & 1 & 1 & 0 & 0 & 0 & 0 & 1 & 1 & 1 & 1 & 0 & 0 \\ 0 & 0 & 0 & 1 & 1 & 1 & 1 & 1 & 1 & 1 & 1 & 0 & 0 & 0 & 0 \\ 0 & 0 & 0 & 0 & 0 & 0 & 0 & 1 & 1 & 1 & 1 & 1 & 1 & 1 & 1 \\ 1 & 0 & 0 & 1 & 0 & 0 & 0 & 0 & 1 & 0 & 0 & 1 & 0 & 0 & 0 \\ 0 & 0 & 1 & 0 & 0 & 0 & 1 & 0 & 1 & 0 & 0 & 0 & 0 & 1 & 0 \\ 0 & 1 & 0 & 0 & 0 & 0 & 0 & 1 & 0 & 0 & 0 & 0 & 1 & 0 & 0 \end{pmatrix} \begin{matrix} N_1 \\ N_2 \\ N_3 \\ N_4 \\ N_5 \\ N_6 \\ N_7 \\ \text{Outputs} \end{matrix}$$

Inputs →

The number of abundant bits does not depend on the one of bits in the Gray code. In other words, the efficiency of the abundant Gray code grows with increasing the number n. So,  $K_c = 15/7$  for  $n = 15$  and  $K_c = 127/10$  for  $n = 127$ .

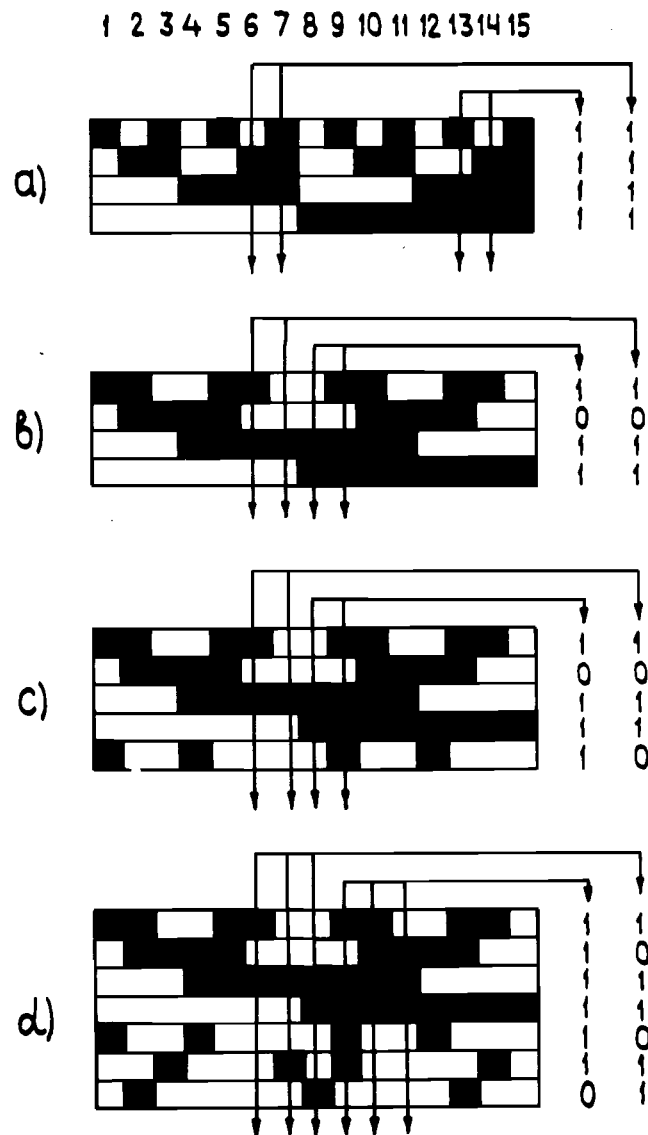

Fig.10. Coding scheme of the scintillation hodoscope:  
 a) usual binary code; b) classical Gray code;  
 c,d) Gray code with additional bits.

Different coding schemes created as a mask of transparent glass and scintillators are given in Fig.10. One can see that the space resolution for cluster registration improves with increasing the number of additional bits. Such a light coding scheme can be created if optical fibers are used.

#### CONCLUSION

Increasing information from multichannel detectors of nuclear particles has generated a need for studying the questions on optimal coding data readout and processing methods. The consideration of specific examples shows that there is a close connection between digital signal processing and correcting code theory. The use of the syndrome coding methods allows one to construct devices for data compression and processing registered in a great number of position-sensitive sources.

The property of the coding word syndrome to carry information on the number and coordinates of errors arising in the process of data transmission is used. It is clear that the method of syndrome coding can be effectively used in other fields of science and engineering technology where information processing from a large number of position-sensitive sources is needed.

Thus, we use both theoretical and practical aspects of the problem to connect such fields as digital data processing and the theory of correcting codes <sup>/18,17/</sup>.

The method of syndrome coding can be commonly used in devices for signature analysis and syndrome testing of large scale-integration microcircuits and microprocessors <sup>/18/</sup>.

#### REFERENCES

1. Nikityuk N.M., Radzhabov R.S., Shafranov M.D. Nucl.Instr. and Meth., 1978, v.155, No.1, p.485.
2. Nikityuk N.M. JINR, P11-80-484, Dubna, 1980.
3. Nikityuk N.M. JINR, P11-81-784, Dubna, 1981, p.13.
4. Nikityuk N.M. JINR, E11-87-10, Dubna, 1987.
5. Nikityuk N.M., Radzhabov R.S., Shafranov M.D. Pribori i Tekhnika Eksperimenta, 1978, No.4, p.95.
6. Gaidamaka R.I., Kalinnikov V.A., Nikityuk N.M. JINR, P13-82-628, Dubna, 1982, p.11.
7. Nikityuk N.M. JINR, P10-87-254, Dubna, 1987, p.14.

8. Massey J.L. IEEE Trans. on Inform. Theory, 1965, vol.IT-11, No.4, p.580-585.
9. Kauts W.H. IEEE Trans. on Inform. Theory, 1964, vol.IT-10, No.5, p.363.
10. Nikityuk N.M. Pribori i Tekhnika Eksperimenta, 1986, No.6, p.78-81.
11. Nikityuk N.M., Selikov A.B. JINR, P10-86-481, Dubna, 1987.
12. Nikityuk N.M. Pribori i Tekhnika Eksperimenta, 1987, No.3, p.59-65.
13. Nikityuk N.M. JINR, P10-87-266, Dubna, 1987.
14. Nikityuk N.M. JINR, P11-87-54, Dubna, 1987.
15. Komolov L.N. et al. Pribori i Tekhnika Eksperimenta, 1987, No.4.
16. Ancheta T.C. IEEE Trans. on Information Theory, 1976, vol.IT-22, No.4, p.432.
17. Blauhut R.E. Proc. IEEE, 1985, vol.73, No.5, p.30-53.
18. Frohwerk R.A. Hewlett Packard Journal, 1977, vol.28, No.9, p.2-8.

Received by Publishing Department  
on January 12 1988.

Никитюк Н.М.

E10-88-28

Метод синдромного кодирования и его применение для сжатия и обработки данных в экспериментах физики высоких энергий

Рассмотрены вопросы применения теории и практики корректирующих кодов для сжатия и обработки данных, регистрируемых в многоканальных детекторах заряженных частиц. Использование метода синдромного кодирования позволяет решить следующие проблемы:

- сокращение числа каналов регистрации при условии ограниченной множественности детектируемых частиц,
- введение избыточности в известные коды, например, в код Грея с целью повышения пространственного разрешения детектора,
- применение метода синдромного кодирования для построения специализированных процессоров.

Основным результатом такого подхода является создание принципиально новых быстродействующих параллельных шифраторов и специализированных процессоров с алгебраической структурой для быстрого отбора событий в спектрометрах физики высоких энергий. Приводятся примеры применения метода синдромного кодирования.

Работа выполнена в лаборатории высоких энергий ОИЯИ.

Препринт Объединенного института ядерных исследований. Дубна 1988

Nikityuk N.M.

E10-88-28

The Method of Syndrome Coding and Its Application for Data Compression and Processing in High Energy Physics Experiments

The questions of using the theory and practice of correcting codes for data compression and processing in multichannel detectors (hodoscopic systems) of nuclear particles are described. A system of analogies between the theories of correcting codes and hodoscopic systems is considered. The following problems are supposed to be solved by syndrome coding:

- the use of syndrome coding for decreasing the number of registration channels in case of a limited multiplicity of registered events;
- the introduction of abundance into known codes, for example into the Gray code, with the aim of increasing the space resolution of a hodoscope.

The main result of this approach is the development of radically new electronic logic units, i.e. parallel encoders for  $t$  events ( $t > 1$ ) and special-purpose processors with algebraic structure (in the Galois field  $GF(2^m)$ ) for fast event selection in nuclear physics experiments.

The investigation has been performed at the Laboratory of High Energies, JINR.

Preprint of the Joint Institute for Nuclear Research. Dubna 1988